

To

AIS-098

**Requirements for the Protection of the Occupants
in the event of an Offset Frontal**

1. Page No. III, Para 5, INTRODUCTION

Substitute following figure for existing one:

UN 94 (Supp. 05 to 02 Series of Amd.)

2. Page No. 4/38 and 5/38, Amendment 1, Specifications

Substitute following text for existing text in paragraph 5.2.8.1

“5.2.8.1 Protection against electrical shock

After the impact at least one of the four criteria specified in paragraphs 5.2.8.1.1 to 5.2.8.1.4. shall be met.

If the vehicle has an automatic disconnect function or device(s) that galvanically divide the electrical power train circuit during driving condition, at least one of the following criteria shall apply to the disconnected circuit or to each divided circuit individually after the disconnect function is activated.

However criteria defined in 5.2.8.1.4 shall not apply if more than a single potential of a part of the high voltage bus is not protected under the conditions of protection degree IPXXB.

In the case that the test is performed under the condition that part(s) of the high voltage system are not energized, the protection against electrical shock shall be proved by either paragraph 5.2.8.1.3 or paragraph 5.2.8.1.4 for the relevant part(s).

For the coupling system for charging the REESS, which is not energized during driving conditions, at least one of the four criteria specified in paragraphs 5.2.8.1.1. to 5.2.8.1.4. below shall be met.”

3. Page No. 8/51 and 9/51, Instructions for users of vehicles equipped with Airbags

Substitute following text for existing text for paragraph no. 6.2.3.

“6.2.3 In the case of a frontal protection airbag on the front passenger seat, the warning shall be durably affixed to each face of the passenger front sun visor in

such a position that at least one warning on the sun visor is visible at all times, irrespective of the position of the sun visor.

Alternatively, one warning shall be on the visible face of the stowed sun visor and a second warning shall be on the roof behind the visor, so, at least one warning is visible at all times. The text size shall allow the label to be easily read by a normal sighted user seated on the seat concerned.

If the vehicle does not have a sun visor or roof, the warning label shall be positioned in a location where it is clearly visible at all times.

In the case of a frontal protection airbag for other seats in the vehicle, the warning shall be directly ahead of the relevant seat, and clearly visible at all times to someone installing a rear-facing child restraint on that seat. The text size shall allow the label to be easily read by a normal sighted user seated on the seat concerned.

This requirement does not apply to those seats equipped with a device which automatically deactivates the frontal protection airbag assembly when any rearward-facing child restraint is installed.”

4. Page No. 11/51, Paragraph no. 7 - Criteria for extension of Type Approvals.

Insert new paragraph 7.5 to be read as follows:

“7.5 For deciding on the worst case or requirement of retest/partial test for extension of an existing type approval, the appropriate available data (i.e. test results/test reports/videos/pictures etc.) provided by the manufacturer may be used with the approval of the test agency.”

PRINTED BY
THE AUTOMOTIVE RESEARCH ASSOCIATION OF INDIA
P.B. NO. 832, PUNE 411 004
ON BEHALF OF
AUTOMOTIVE INDUSTRY STANDARDS COMMITTEE
UNDER
CENTRAL MOTOR VEHICLE RULES – TECHNICAL STANDING
COMMITTEE
SET-UP BY
MINISTRY OF ROAD TRANSPORT & HIGHWAYS
(DEPARTMENT OF ROAD TRANSPORT & HIGHWAYS)
GOVERNMENT OF INDIA
28 September 2016

AMENDMENT NO. 1 15 December 2015

To

AIS-098

**Requirements for the Protection of the Occupants
in the event of an Offset Frontal**

1. Page No. III, Para 5, INTRODUCTION

Substitute following text for existing text:

UN R 94 (Supp. 3 to 02 Series of Amd.) Uniform Provisions concerning the approval of vehicles with regard to the protection of the occupants in the event of frontal collision.

2. Page No. III, Para 6, INTRODUCTION

Substitute following text for existing text and Add new para after para 6 as given below:

The Automotive Industry Standards Committee responsible for preparation of this standard is given in Annex: 9

Amendment No. 1 is issued to incorporate requirements for the protection of the occupants of vehicles operating on electrical power, Air bag warning label, Hybrid 3 dummy specifications as agreed time to time, post publication of AIS-098:2008

3. Page 2/51. Add new Clause 2.6.7. as below:

2.6.7 The locations of the Rechargeable Electrical Energy Storage Systems (REESS), in so far as they have a negative effect on the result of the impact test prescribed in this standard.

4. Page 2/51. Clause 2.7.

Substitute following text for existing text:

2.7 "Passenger Compartment"

2.7.1 **"Passenger compartment with regard to occupant protection"** means the space for occupant accommodation, bounded by the roof, floor, side walls, doors, outside glazing and front bulkhead and the plane of the rear compartment bulkhead or the plane of the rear-seat back support;

2.7.2 **"Passenger compartment for electric safety assessment"** means the space for occupant accommodation, bounded by the roof, floor, side walls, doors, outside glazing, front bulkhead and rear bulkhead, or rear gate, as well as by the electrical protection barriers and enclosures provided for protecting the occupants from direct contact with high voltage live parts.

5. Page No. 3/51, Clause 2.15. to Clause 2.20.

Delete text "(Reserved)" and Add new definitions as follows:

- 2.15. **"High voltage"** means the classification of an electric component or circuit, if its –
60V < working voltage (DC) \leq 1500 V; or
30 V < working voltage (AC) rms \leq 1000 V;
- 2.16. **"Rechargeable electrical energy storage system (REESS)"** means rechargeable electrical energy storage system which provides electrical energy for propulsion;
- 2.17. **"Electrical protection barrier"** the part providing protection against any direct contact to the high voltage live parts;
- 2.18. **"Electrical power train"** means the electrical circuit which includes the traction motor(s), and may also include the REESS, the electrical energy conversion system, the electronic converters, the associated wiring harness and connectors, and the coupling system for charging the REESS;
- 2.19. **"Live parts"** means conductive part(s) intended to be electrically energized in normal use;
- 2.20. **"Exposed conductive part"** means the conductive part which can be touched under the provisions of the protection degree IPXXB and which becomes electrically energized under isolation failure conditions. This includes parts under a cover that can be removed without using tools.

6. Page No. 3/51, Clause 2.21.

Add new definitions Clause 2.21 to Clause 2.34 as follows:

- 2.21 **"Direct contact"** means the contact of persons with high voltage live parts;
- 2.22. **"Indirect contact"** means the contact of persons with exposed conductive parts;
- 2.23. **"Protection Degree IPXXB"** means protection from contact with high voltage live parts provided by either an electrical protection barrier or an enclosure and tested using a Jointed Test Finger (Degree IPXXB) as described in paragraph 4. of Annex 8;
- 2.24. **"Working voltage"** means the highest value of an electrical circuit voltage root-mean-square (rms), specified by the vehicle manufacturer, which may occur between any conductive parts in open circuit conditions or under normal operating conditions. If the electrical circuit is divided by galvanic isolation, the working voltage is defined for each divided circuit, respectively;

- 2.25. **"Coupling system for charging the rechargeable electrical energy storage system (REESS)"** means the electrical circuit used for charging the REESS from an external electrical power supply including the vehicle inlet;
- 2.26. **"Electrical chassis"** means a set made of conductive parts electrically linked together, whose electrical potential is taken as reference;
- 2.27. **"Electrical circuit"** means an assembly of connected high voltage live parts which is designed to be electrically energized in normal operation;
- 2.28. **"Electric energy conversion system"** means a system that generates and provides electrical energy for electrical propulsion;
- 2.29. **"Electronic converter"** means a device capable of controlling and/or converting electrical power for electrical propulsion;
- 2.30. **"Enclosure"** means the part enclosing the internal units and providing protection against any direct contact;
- 2.31. **"High Voltage Bus"** means the electrical circuit, including the coupling system for charging the REESS that operates on a high voltage;
- 2.32. **"Solid insulator"** means the insulating coating of wiring harnesses provided in order to cover and prevent the high voltage live parts from any direct contact. This includes covers for insulating the high voltage live parts of connectors; and varnish or paint for the purpose of insulation;
- 2.33. **"Automatic disconnect"** means a device that when triggered, galvanically separates the electrical energy sources from the rest of the high voltage circuit of the electrical power train;
- 2.34. **"Open type traction battery"** means a type of battery requiring liquid and generating hydrogen gas released to the atmosphere.

7. Page No. 3/51, Clause 2.21.

Clause 2.21. (former) rename as Clause 2.35

8. Page No. 4/51, APPLICATION FOR APPROVAL

Add following new Clause 3.2.6. after clause 3.2.5.

- 3.2.6. A general description of the electrical power source type, location and the electrical power train (e.g. hybrid, electric).

9. Page No. 5/51, General specifications applicable to all tests

Substitute following text for existing text in the Clause no. 5.1.2.

5.1.2. When the protective system for the front seating positions includes belts, the belt components shall meet the requirements of IS: 15140 as amended from time to time.

Add new Clause 5.1.3. as follows after Clause 5.1.2.

5.1.3. Seating positions where a dummy is installed and the protective system includes belts, shall be provided with anchorage points conforming to IS: 15139.as amended from time to time.

10. Page No. 5/51, Specifications

Add paragraph 2 in existing Clause 5.2 text as given below:

5.2. Specifications

The test of the vehicle carried out in accordance with the method described in Annex 1 shall be considered satisfactory if all the conditions set out in paragraphs 5.2.1 to 5.2.6 below are all satisfied at the same time.

Additionally, vehicles equipped with electric power train shall meet the requirements of paragraph 5.2.8. below. This can be met by a separate impact test at the request of the vehicle manufacturer and after validation by the testing agency, provided that the electrical components do not influence the occupant protection performance as defined in paragraphs 5.2.1. to 5.2.5. of this standard of the vehicle type in consideration. In case of this condition the requirements of paragraph 5.2.8. shall be checked in accordance with the methods set out in Annex 1 to this standard, except paragraphs, 2., 5., and 6. of Annex 1. A dummy corresponding to the specifications for Hybrid III (as specified in Annex 7) fitted with a 45° angle and meeting the specifications for its adjustment shall be installed in each of the front outboard seats.

11. Page No. 7/51, Specifications

Add new Clause 5.2.8. with sub-clauses after Clause 5.2.7. as given below:

5.2.8. Following the test conducted in accordance with the procedure defined in Annex 1 to this Standard the electrical power train operating on high voltage and the high voltage components and systems which are galvanically connected to the high voltage bus of the electrical power train shall meet the following requirements:

5.2.8.1 Protection against electrical shock

After the impact at least one of the four criteria specified in paragraphs 5.2.8.1.1 to 5.2.8.1.4. shall be met.

If the vehicle has an automatic disconnect function or device(s) that galvanically divide the electrical power train circuit during driving condition, at least one of the following criteria shall apply to the disconnected circuit or to each divided circuit individually after the disconnect function is activated.

However criteria defined in 5.2.8.1.4 shall not apply if more than a single potential of a part of the high voltage bus is not protected under the conditions of protection degree IPXXB.

In the case that the test is performed under the condition that part(s) of the high voltage system are not energized, the protection against electrical shock shall be proved by either paragraph 5.2.8.1.3 or paragraph 5.2.8.1.4 for the relevant part(s).

5.2.8.1.1 Absence of high voltage

The voltages V_b , V_1 and V_2 of the high voltage buses shall be \leq than 30 V_{AC} or 60 V_{DC} as specified in paragraph 2. of Annex 8.

5.2.8.1.2. Low electrical energy

The total energy (TE) on the high voltage buses shall be < 2.0 J when measured according to the test procedure as specified in paragraph 3, formula (a) of Annex 8. Alternatively the total energy (TE) may be calculated by the measured voltage V_b of the high voltage bus and the capacitance of the X-capacitors (C_x) specified by the vehicle manufacturer in paragraph 3, formula (b) of Annex 8.

The energy stored in the Y-capacitors (TE_{y1} , TE_{y2}) shall also be < 2.0 J. This shall be calculated by measuring the voltages V_1 and V_2 of the high voltage buses and the electrical chassis, and the capacitance of the Y-capacitors specified by the vehicle manufacturer according to formula (c) in paragraph 3 of Annex 8.

5.2.8.1.3 Physical protection

For protection against direct contact with high voltage live parts, the protection degree IPXXB shall be provided.

In addition, for protection against electrical shock, which could arise from indirect contact, the resistance between all exposed conductive parts and the electrical chassis shall be $< 0.1 \Omega$ when there is current flow of at least 0.2 Amp.

This requirement is satisfied if the galvanic connection has been made by welding.

5.2.8.1.4 Isolation resistance

The criteria specified in the paragraphs 5.2.8.1.4.1 and 5.2.8.1.4.2 below shall be met.

The measurement shall be conducted in accordance with paragraph 5. of Annex 8.

5.2.8.1.4.1 Electrical power train consisting of separate DC- or AC-buses

If the AC high voltage buses and the DC high voltage buses are galvanically isolated from each other, isolation resistance between the high voltage bus and the electrical chassis (R_i as defined in paragraph 5. of Annex 8) shall have a minimum value of 100 Ω /volt of the working voltage for DC buses, and a minimum value of 500 Ω /volt of the working voltage for AC buses.

5.2.8.1.4.2. Electrical power train consisting of combined DC- and AC-buses

If the AC high voltage buses and the DC high voltage buses are galvanically connected isolation resistance between the high voltage bus and the electrical chassis (R_i as defined in paragraph 5. of Annex 8) shall have a minimum value of 500 Ω /volt of the working voltage.

However, if the protection degree IPXXB is satisfied for all AC high voltage buses or the AC voltage ≤ 30 V after the vehicle impact, the isolation resistance between the high voltage bus and the electrical chassis (R_i as defined in paragraph 5 of Annex 8) shall have a minimum value of 100 Ω /volt of the working voltage.

5.2.8.2 Electrolyte spillage

In the period, from the impact until 30 minutes after, no electrolyte from the REESS shall spill into the passenger compartment, and no more than 7 % of electrolyte shall spill from the REESS except, open type traction batteries outside the passenger compartment. For open type traction batteries no more than 7 % with a maximum of 5.0 liters shall spill outside the passenger compartment. The vehicle manufacturer shall demonstrate compliance in accordance with paragraph 6. of Annex 8.

5.2.8.3 REESS retention

REESS located inside the passenger compartment shall remain in the location in which they are installed and REESS components shall remain inside REESS boundaries.

No part of any REESS that is located outside the passenger compartment for electrical safety assessment shall enter the passenger compartment during or after the impact test.

The manufacture shall demonstrate compliance in accordance with paragraph 7 of Annex 8.

12. Page No. 8/51, Instructions for users of vehicles equipped with Airbags

Substitute following text for existing text in Clause 6.2.1.:

6.2.1 As a minimum, this information shall consist of a label containing a pictogram and text warning as indicated below.

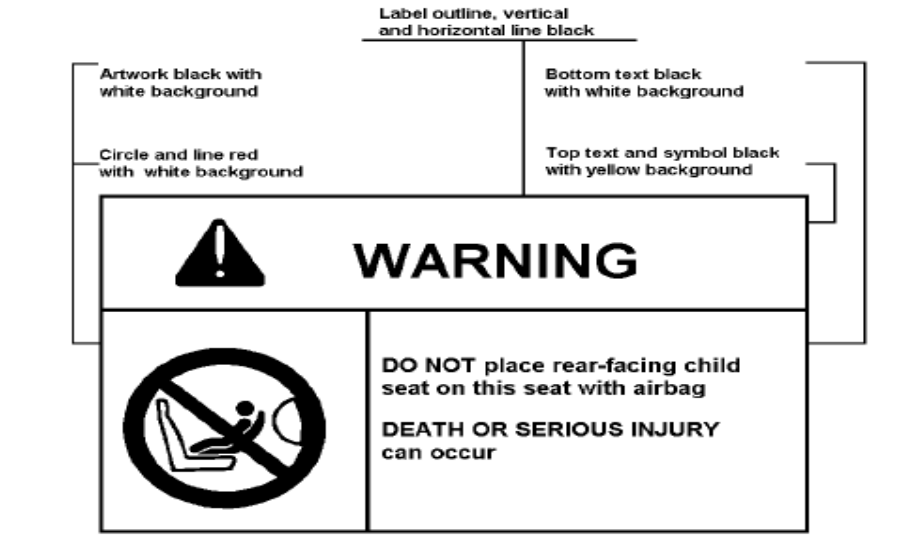

OR

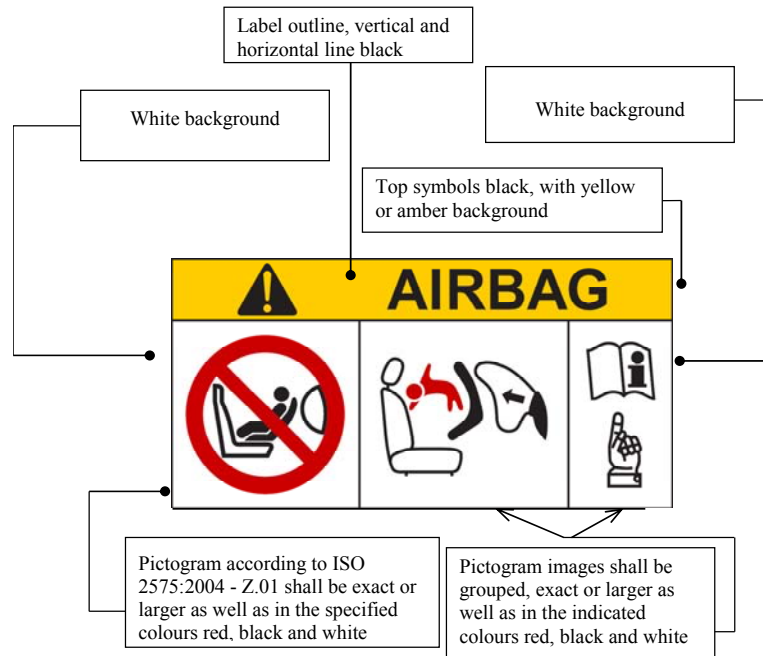

The overall dimensions shall be 120 x 60 mm or the equivalent area, as a minimum.

The label shown above may be adapted in such a way that the layout differs from the example above; however, the text content shall meet the above prescriptions.

13. Page No. 9/51, Instructions for users of vehicles equipped with Airbags

Substitute following text for existing text in the Clause 6.2.4.:

6.2.4 Detailed information, making reference to the warning, shall be contained in the owner's manual of the vehicle; as a minimum the following text in Hindi or English, shall include:

"NEVER use a rearward facing child restraint on a seat protected by an ACTIVE AIRBAG in front of it, DEATH or SERIOUS INJURY to the CHILD can occur"

The text shall be accompanied by an illustration of the warning to be found in the vehicle.

14. Page No. 9/51, Criteria for extension of type approvals

Clause 7.1. amend to read as given below:

7.1 While examining, number of front seats,

15. Page No. 13/51, Annex 1, State of Vehicle

Substitute following text for existing text in Clause 1.4.3.1.:

1.4.3.1. Position of steering wheel

The steering wheel, if adjustable, shall be placed in the normal position indicated by the vehicle manufacturer or, in the absence of any specific recommendation by the vehicle manufacturer, midway between the limits of its range(s) of adjustment. At the end of propelled travel, the steering wheel shall be left free, with its spokes in the position, which according to the vehicle manufacturer corresponds to straight-ahead travel of the vehicle.

16. Page No. 13/51, Annex 1, State of Vehicle

Substitute following text for existing text in Clause 1.4.3.3.:

1.4.3.3. Gear-change lever position

The gear-change lever shall be in the neutral position. If the test vehicle is driven by its own engine, then the gear-change lever position shall be defined by the vehicle manufacturer.

17. Page No. 14/51, Annex 1, State of Vehicle

Add new Clause 1.4.4. with sub-clauses after Clause 1.4.3.11.3. as given below:

1.4.4. Electrical power train adjustment

- 1.4.4.1. The REESS shall be at any state of charge, which allows the normal operation of the power train as recommended by the vehicle manufacturer.
- 1.4.4.2. The electrical power train shall be energized with or without the operation of the original electrical energy sources (e.g. engine-generator, REESS or electric energy conversion system), however:
 - 1.4.4.2.1. By the agreement between Test Agency and vehicle manufacturer it shall be permissible to perform the test with all or parts of the electrical power train not being energized in so far as there is no negative influence on the test result. For parts of the electrical power train not energized, the protection against electrical shock shall be proved by either physical protection or isolation resistance and appropriate additional evidence.
 - 1.4.4.2.2. In the case where an automatic disconnect is provided, at the request of the vehicle manufacturer it shall be permissible to perform the test with the automatic disconnect being triggered. In this case it shall be demonstrated that the automatic disconnect would have operated during the impact test. This includes the automatic activation signal as well as the galvanic separation considering the conditions as seen during the impact.

18. Page No. 14/51, Annex 1, Dummies

Substitute following text for existing text in Clause 2.1. and delete foot note no. 1:

- 2.1.1 A dummy complying with the requirements of Hybrid III[†]-50th percentile male dummy as specified in Annex 7 shall be installed in each of the front outboard seats in accordance with the conditions set out in Annex 5.

The dummy shall be certified in accordance with the procedures in Annex 7

19. Page No. 15/51, Annex 1, Dummies

Substitute following text for existing text in Clause 2.1.1.1. and Clause 2.1.2.:

- 2.1.1.1. However at the choice of the vehicle manufacturer, the lower foot calibration test can be demonstrated either in without shoe condition (paragraph 2 8.8 of Annex 7) or in with shoe condition (paragraph 3 8.9 of Annex 7).
- 2.1.2 The vehicle will be tested with restraint systems, as provided by the vehicle manufacturer.

20. Page No. 22/51, Annex 3, Arrangement and installation of dummies and adjustment of restraint systems

Substitute following text for existing text in Clause 2.6.1.:

- 2.6.1. The right foot centreline of the vehicle. For vehicles equipped with a footrest, it shall be possible at the request of the manufacturer to place the left foot on the designated footrest. In this case the position of the left foot is defined by the footrest.

21. Page No. 44/51, Annex 7,

Substitute following text for existing text in the Title of the Annex 7 and delete footnote 1.

New Clause no. 1 to 8.6 with sub-clauses to be included before existing clauses and renumber former clauses as given below:

ANNEX 7

(See Annex 1- 2.1.1)

Hybrid III 50th %le Male dummy¹ Technical description of a frontal impact dummy.

1. **Introduction:**

- 1.1. The frontal impact dummy prescribed in this document, including the instrumentation and calibration, is described in technical drawings and a user's manual.
- 1.2. The dimensions and masses of the frontal impact dummy represent a 50th percentile adult male of American anthropometry.
- 1.3. The Hybrid III dummy shall be fitted with a 45 degree ankle and meeting the specifications for its adjustment.

2. **Construction:**

- 2.1. **Head:** The skull and skull cap are cast aluminum parts with removable vinyl skins.
- 2.2. **Neck:** The neck is a segmented rubber and aluminum construction with a center cable. The neck unit consists of two neck brackets. these brackets are adjusted to adjust the neck angle.
- 2.3. **Upper Torso:** it consists of rib cage, sternum, thoracic spine, clavicle link & scapulae and bib.
 - 2.3.1. The rib cage is represented by 6 high strength steel ribs with polymer based damping material. Each rib unit is in one continuous part open at the sternum and anchored to the back of the thoracic spine.

¹ **References:**

- I. Humanetics Innovative solutions. Hybrid III 50th Male dummy user manual. Revision C, 2011. Ref. no: 78051-9900 :2012
- II. <http://www.humaneticsatd.com/crash-test-dummies/frontal-impact/hybrid-iii-50th>.
- III. FMVSS Part 572, subpart E (50th %le Male) Dummy performance calibration test procedure. Appendix A, TP208-14.
- IV. http://www.unece.org/trans/main/wp29/wp29_dummyspec.html

- 2.3.2. A sternum connects the front of the ribs and includes a slider for the chest deflection rotary potentiometer. Bib is connected to the front of the rib cage assembly to the sternum covering the complete rib cage.
- 2.3.3. A two-piece aluminum clavicle and clavicle link assemblies have cast integral scapulae to interface with shoulder belts.
- 2.3.4. A curved cylindrical rubber lumbar spine provides human-like slouch of a seated person and is attached to the pelvis. It is also possible to include an optional 3 axis lumbar load cell.
- 2.4. **Lower Torso:** It consists of pelvis, femur, knee, tibia & feet.
 - 2.4.1. The pelvis is vinyl skin/urethane foam molded over an aluminum casting. The ball-jointed femur attachments carry bump stops to reproduce the human leg to hip moment/rotation characteristics.
 - 2.4.2. The femur is connected to pelvis through bolting.
 - 2.4.3. The femur, tibia and ankle can be instrumented to predict bone fracture and the knee can evaluate tibia to femur ligament injury.
 - 2.4.4. The dummy mid sagittal plane passes from the dummy ventral to dorsal dividing the dummy into right and left parts.

3. **Dummy External measurements**

Test parameter	Designation	mm
Sitting Height	A	883.9 ± 5.1
Shoulder Pivot Height	B	513.1 ± 7.6
H-Point Height (ref.)	C	86.4 ± 2.5
H-Point from Seat Back (ref.)	D	137.2 ± 2.5
Shoulder Pivot from Backline	E	88.9 ± 5.1
Thigh Clearance	F	147.3 ± 7.6
Back of Elbow to Wrist pivot	G	297.2 ± 7.6
Skull Cap to Backline	H	43.2 ± 2.5
Shoulder to Elbow Length	I	337.8 ± 7.6
Elbow Rest Height	J	200.7 ± 10.2
Buttock to Knee Length	K	591.8 ± 12.7
Popliteal Height	L	442.0 ± 12.7
Knee Pivot to Floor Height	M	492.8 ± 7.6
Buttock Popliteal height	N	464.8 ± 12.7
Chest Depth	O	221.0 ± 7.6
Foot Length	P	259.1 ± 7.6
Foot Width	R	99.1 ± 7.6
Shoulder Width	V	429.3 ± 7.6
Hip Width at H-Point	W	363.2 ± 7.6
Chest Circumference	Y	985.5 ± 15.2
Waist Circumference	Z	850.9 ± 15.2
Reference Location for Chest Circumference (ref.)	AA	431.8 ± 2.5
Reference Location for Waist Circumference (ref.)	BB	228.6 ± 2.5

Table 1: Dummy external dimensions.

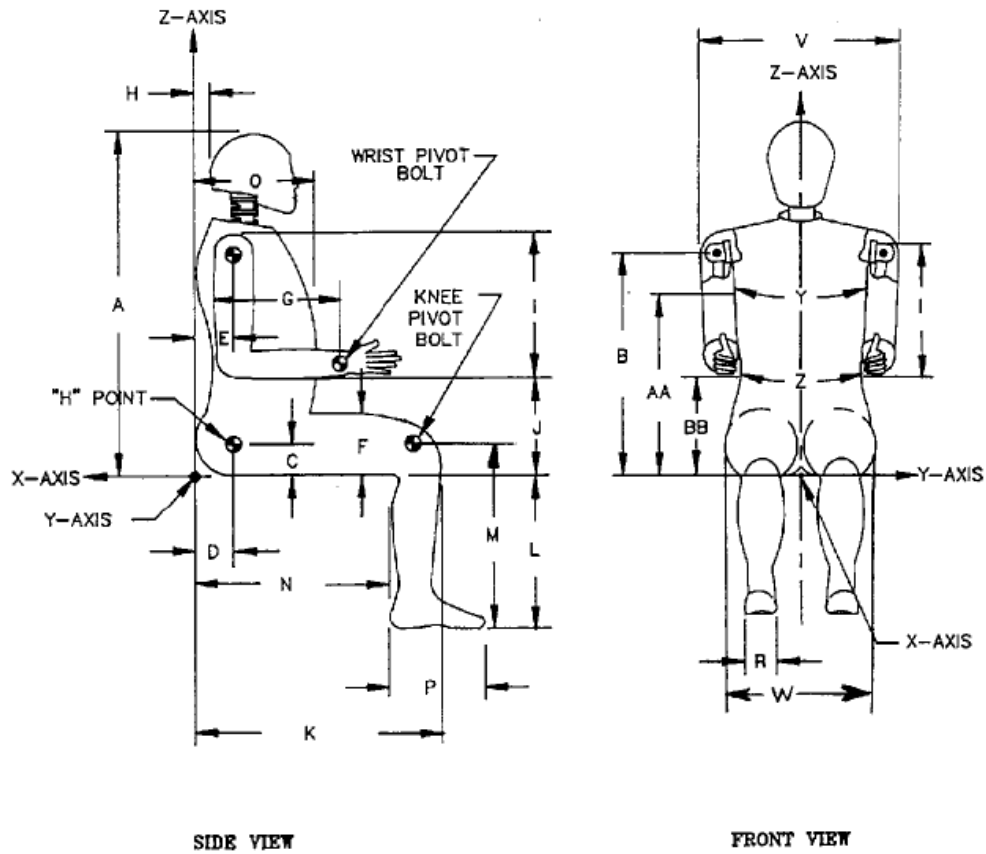

NOTE: FIGURE IS REFERENCED TO THE ERECT SEATED POSITION.

Fig 1: External Dimensions setup specification.

4. The weight specification of different dummy parts are

Part	Weight (kg)
Head	4.54 ± 0.05
Neck	1.54 ± 0.05
Upper Torso	17.19 ± 0.14
Lower Torso	23.04 ± 0.14
Upper Arm, Left or Right	2.0 ± 0.05
Hands, Left or Right	0.57 ± 0.05
Lower Arms, Left or Right	1.70 ± 0.05
Upper Leg, Left or Right	5.99 ± 0.09
Lower Legs, Left or Right	5.44 ± 0.05
Feet, Left or Right	1.16 ± 0.05
Total Weight	77.70 ± 1.18

Table 2: Dummy component weights.

5. Instrumentation on the dummy:

Location	Measurement	Channels	Regulatory requirement	Optional
Head C.G	Acceleration	3	X	
Head	Angular acceleration	9 or 12		X
Head	Angular Rate	3		X
Head-neck interface	Force & Moment	3	X	
Head-neck interface	Force & Moment	6		X
Thorax C.G.	Acceleration	3	X	
Thoracic spine	Force & Moment	5		X
Sternum	Displacement	1	X	
Sternum	Displacement	8		X
Lumbar spine	Force & Moment	5		X
Pelvis	Acceleration	3		X
Pelvis	Lap Belt Position	6		X
Upper Femur	Force & Moment	6 each		X
Lower Femur	Force	1 each	X	
Lower Femur	Force & Moment	6 each		X
Knee-Tibia	Displacement	1 each	X	
Knee-Clevis	Force	2 each		X
Upper Tibia	Force & Moment	4 each	X	
Lower Tibia	Force & Moment	4 each	X	
Foot/Ankle/Toe	Force & Moment	6 each		X
Shoulder	Forces	2 each		X
Sternum	Accelerations	2		X

Table 3: Dummy Instrumentation.

6. The following are the calibration tests carried out on the dummy:

Test	Description
Head	Head Drop
Neck	flexion / extension
Whole body	Thorax Impact test
Knee	Knee Impact & Knee Shear Test
Hip	Hip joint rotation test
Foot	foot impact test

Table 4: Dummy Calibration fixtures.

7. **Test lab environmental conditions for calibration and soaking**

Dummy test component	Temperature (°C)	Relative Humidity (%)	Min. Soaking Duration Prior to Test (Hr)
Head	20.6 to 22.2	10 to 70	4
Neck	20.6 to 22.2		
Knee - Shear	20.6 to 22.2		
Thorax	20.6 to 22.2		
Knee – Impact	18.9 to 25.6		
Hip range of motion	18.9 to 25.6		
Foot	19 to 25		

Note: The soak period shall not include the time required to reach steady state conditions

8. Dummy Calibration:

8.1. Head Drop Test:

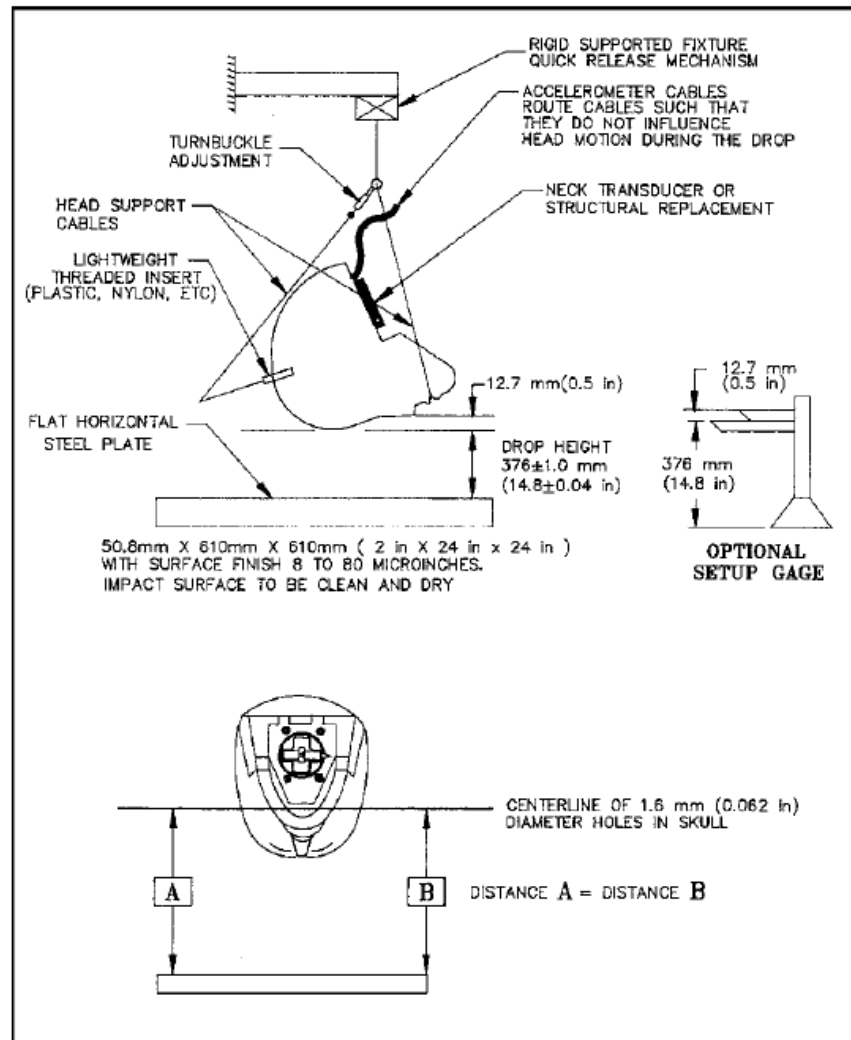

Fig 2: Head drop test setup.

- 8.1.1. This test measures the forehead response to frontal impact with a hard surface.
- 8.1.2. The mass of the head assembly is $4.54 \text{ kg} \pm 0.05 \text{ kg}$. 3 uni-axial or 1 tri axial accelerometers are positioned at the CG of the head assembly.
- 8.1.3. The test fixture, as shown in fig 2, consists of a structure to suspend the head assembly and a rigidly supported, flat, horizontal, steel plate. The square plate should be $50.8 \text{ mm} \pm 2 \text{ mm}$ thick, with side of $610 \text{ mm} \pm 10 \text{ mm}$, and have a smooth surface finish of 8 to 80 micro inches/inch rms. A surface finish close to 8 micro inches/inch rms is preferred. The suspension system and accelerometer cable masses should be as light as possible to minimize the external forces acting on the head. [Effective suspension cable and accelerometer cable masses should be less than 25 g. Effective mass can be estimated by multiplying the mass/unit length of the cable by the length of cable between the head and the first support.]

- 8.1.4. The Data Acquisition System, including transducers, must conform to the specifications of the latest revision of SAE Recommended Practice J211-1. Filter all data channels using Channel Class 1000 phaseless filters.
- 8.1.5. Test Procedure:
 - 8.1.5.1 Inspect the head skin for cracks, cuts, abrasions, etc visually. Replace or repair the head skin if abrasions or cuts to the frontal area are more than superficial.
 - 8.1.5.2 Clean the impact surface of the skin and the impact plate surface with isopropyl alcohol or an equivalent. The impact surface and the skin must be clean and dry for testing.
 - 8.1.5.3 Torque the 1/4-20 skull cap screws to 18 Nm and the 10-24 accelerometer mount cap screws to 7.5 Nm
 - 8.1.5.4 Mount the accelerometers in the head on the horizontal transverse bulkhead so the sensitive axes intersect at the center of gravity point.
 - 8.1.5.4.1 One accelerometer is aligned with the sensitive axis perpendicular to the horizontal bulkhead in the midsagittal plane (Z-axis).
 - 8.1.5.4.2 The second accelerometer is aligned with the sensitive axis parallel to the horizontal bulkhead in the midsagittal plane (X-axis).
 - 8.1.5.4.3 The third accelerometer is aligned with its sensitive axis parallel to the horizontal bulkhead and perpendicular to the midsagittal plane (Y-axis). Ensure that all transducers are properly installed, oriented and calibrated.
 - 8.1.5.5 Suspend the head assembly in a manner similar to that shown in Figure 2. The lowest point on the forehead is $12.7 \text{ mm} \pm 1 \text{ mm}$ below the lowest point of the dummy's nose when the midsagittal plane is vertical. The 1.6 mm diameter holes located on either side of the head are used to ensure that the head is level with respect to the impact surface.
 - 8.1.5.6 Drop the head assembly from a height of $376 \text{ mm} \pm 1 \text{ mm}$ by a means that ensures a smooth, clean release onto the impact surface.
 - 8.1.5.7 Time-zero is defined as the point of contact between the head and the impact surface. All data channels should be at the zero level at this time.
- 8.1.6. Performance Specifications:
 - 8.1.6.1 The peak resultant acceleration should be between 225 g and 275 g, inclusive. (g- gravitational acceleration 9.81 m/sec^2)
 - 8.1.6.2 The resultant acceleration versus time history curve shall be unimodal to the extent that oscillations occurring after the main acceleration pulse are less than 10% (zero to peak) of the main pulse.
 - 8.1.6.3 The lateral acceleration vector should not exceed 15 G.

8.2 Neck Tests

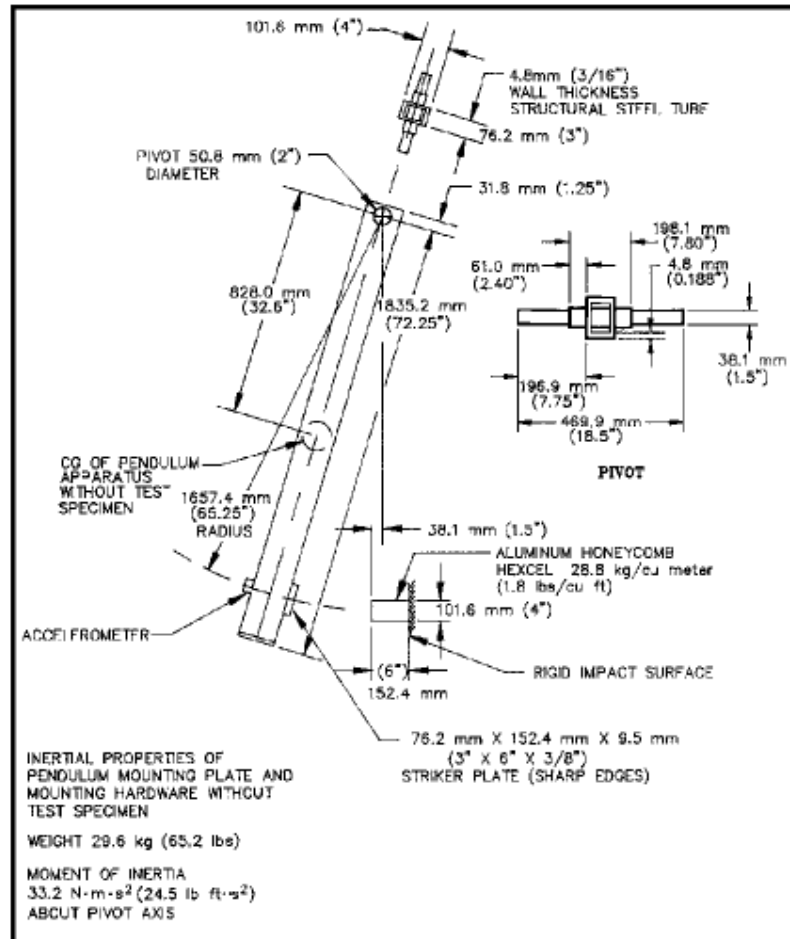

Fig 3: Neck pendulum arm specifications.

8.2.1 The components required for the neck tests are:

- Head assembly.
- Neck assembly.
- Upper neck bracket.
- Lower neck bracket.
- Bib simulator.
- 3 or 6-channel neck transducer to measure the X-axis force and the Y-axis moment.
- Transducers to measure the rotation of the D-plane (horizontal plane through the base of the skull) with respect to the pendulum's longitudinal centerline.
- 3 actual or simulated accelerometers in the head to maintain the proper weight and center of gravity location; however the data from the accelerometers is not required.
- A uni-axial (x) accelerometer is placed on the pendulum at a distance of 1657.4 mm from pivot point as shown in fig 3.
- Nodding block is a rubber component used to limit the lateral head moment about the x-axis.

- 8.2.2 The test fixture as shown in fig 3, consists of pendulum arm with specifications shown. The aluminum honeycomb material which acts as a rigid impacting surface is made of commercial grade, 0.8 kg per cubic ft with 19 mm diameter cells. Mount the accelerometer with its sensitive axis aligned with the arc formed at a radius 1657.4 mm from the pivot point.
- 8.2.3 The data acquisition system, including transducers, must conform to the specifications of the latest revision of SAE Recommended Practice J211-1. Using phase less filters;
- a) Filter the neck force data channel using Channel Class 1000,
 - b) The neck moment data channel using Channel Class 600,
 - c) The pendulum acceleration data channel using Channel Class 180,
 - d) The neck rotation data channels using Channel Class 60.
- 8.2.4 Test Procedure:
- 8.2.4.1 Check that internal neck temperature reaches the soak temperature by placing a thermo-sensor into one of the holes in the neck.
- 8.2.4.2 Inspect the neck assembly for cracks, cuts, and separation of the rubber from the metal segment.
- 8.2.4.3 Inspect the nodding blocks for any deterioration and replace as necessary. Replace the blocks if they are less than 80% of their original height. The durometer should be 80 to 90 shore A. Ensure that the nodding blocks are installed correctly.
- 8.2.4.4 Inspect the nodding block joint with head to neck adapter bracket, for an interference fit. Adjust or replace as required.
- 8.2.4.5 Mount the head-neck assembly on the pendulum so the mid sagittal plane of the head is vertical when the pendulum arm is aligned vertically.
- 8.2.4.6 Figure 4 shows test set up for the Flexion test and Figure 5 for the Extension test.
- 8.2.4.7 Install the transducers or other devices for measuring the D-plane rotation with respect to the pendulum longitudinal centerline. These measurement devices should be designed to minimize their influence on the performance of the head-neck assembly.
- 8.2.4.8 Torque the jam nut on the neck cable to $1.36 \text{ Nm} \pm 0.27 \text{ Nm}$ before each test on the same neck.

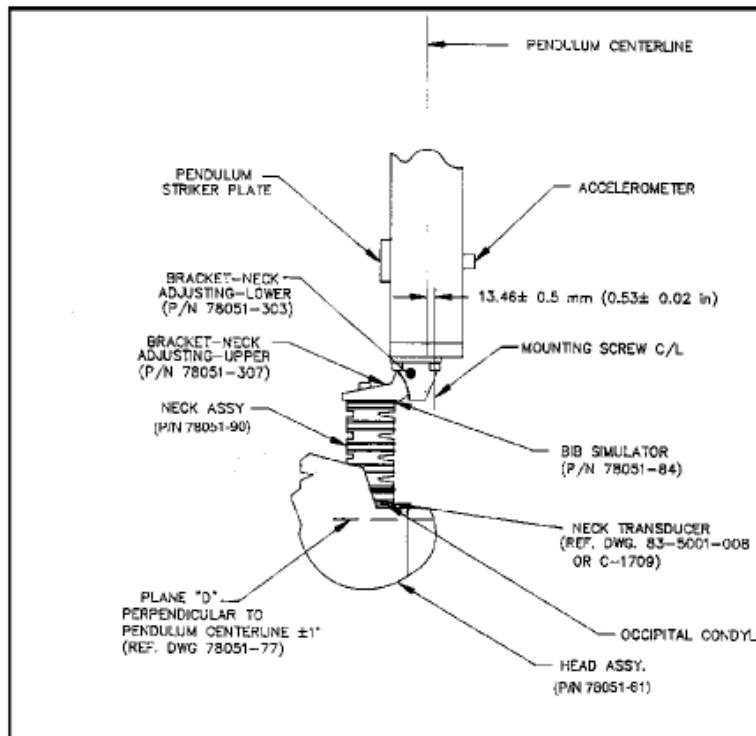

Fig 4: Neck flexion test setup.

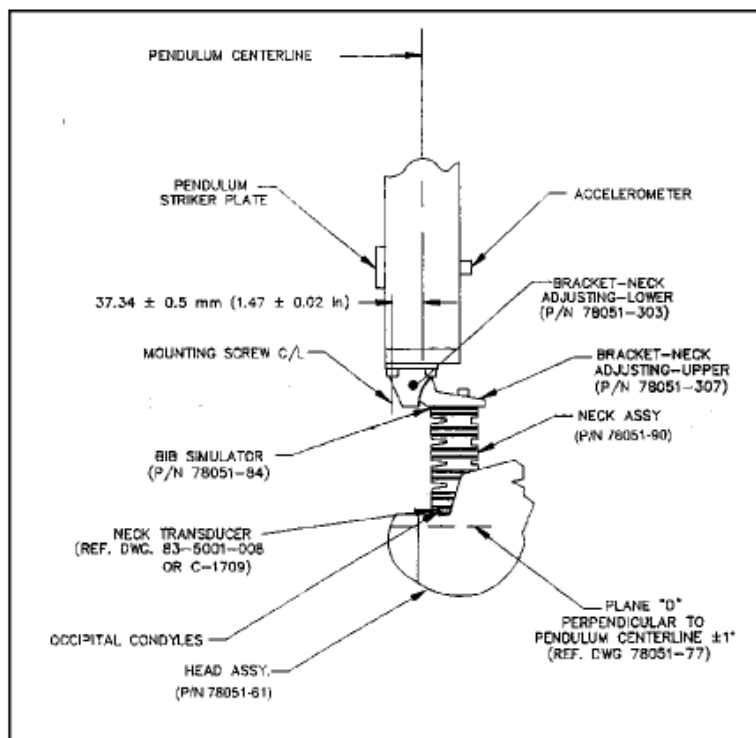

Fig 5: Neck flexion test setup.

8.2.4.9 The number of cells in the honeycomb material required to produce the pendulum input pulse are different for the flexion and extension tests. The number of cells required may also vary for each sheet and/or batch of material. Prior to the test, it is an option to pre-crush the honeycomb material by lightly impacting it so 90 to 100% of the projected honeycomb surface contacts the pendulum strike plate.

- 8.2.4.10 The honey comb material having 17-18 cells are used in tension tests; and honeycomb with 25-26 cells used in flexion tests, the other dimensions are kept same.
- 8.2.4.11 With the pendulum resting against the honeycomb material, adjust the neck bracket until the longitudinal centerline of the pendulum is perpendicular within ± 1 degree to the D-plane on the dummy's head.
- 8.2.4.12 Wait at least 30 minutes between successive tests on the same neck.
- 8.2.4.13 Calculate the moment about the occipital condyles for both flexion and extension tests using the formulas (Metric Units):²

For a 3-channel neck transducer:

$$\text{Moment} = M_y - 0.008763 \times F_x$$

For a 6-channel neck transducer:

$$\text{Moment} = M_y - 0.01778 \times F_x$$

8.2.5 Performance Specifications - Neck Flexion

- 8.2.5.1 Release the pendulum and allow it to fall freely from a height to achieve a velocity of 6.89 to 7.13 m/s , measured at the center of the accelerometer.
- 8.2.5.2 Time-zero is defined as the time of initial contact between the pendulum striker plate and the honeycomb material. All data channels should be at the zero level at this time.
- 8.2.5.3 Stop the pendulum from the initial velocity with acceleration versus time pulse which meets the velocity change as specified in Table 5, Integrate the pendulum acceleration data channel to obtain the velocity versus time curve.

Time (ms)	Pendulum deceleration (g)
10	22.5-27.5
20	17.6-22.6
30	12.5-18.5
After 30	29.0 max

Table 5: Pendulum deceleration for neck flexion.

(g – Gravitational acceleration = 9.81 m/sec²)

- 8.2.5.4 The maximum rotation of the head D-plane should be between 64 to 78 degrees with respect to the pendulum and should occur between 57 and 64 milliseconds after time zero. The decaying head rotation versus time curve should cross the zero angle between 113 and 128 milliseconds after time-zero.

² The formulas are based on the sign convention contained in the latest revision of SAE Recommended Practice J211-1 and SAE Information Report J1733.

8.2.5.5 The moment about the Y-axis of the head, measured with respect to the occipital condyles, has a maximum value between 88.1 and 108.4 Nm and should occur between 47 and 58 milliseconds. The decaying moment versus time curve should first cross zero between 97 and 107 milliseconds after time-zero.

8.2.6 Performance Specifications - Neck Extension

8.2.6.1 Release the pendulum and allow it to fall freely from a height to achieve an impact velocity of 5.94 to 6.19 m/s, measured at the center of the accelerometer.

8.2.6.2 Time-zero is defined as the time of initial contact between the pendulum striker plate and the honeycomb material. All data channels should be at the zero level at this time.

8.2.6.3 Stop the pendulum from the initial velocity with acceleration versus time pulse which meets the values specified in Table 6.

Time (ms)	Pendulum deceleration (g)
10	17.2-21.2
20	14-19
30	11-16
After 30	22.0 max

Table 6: Pendulum deceleration for neck extension.

8.2.6.4 The maximum rotation of the head D-plane should be between 81 to 106 degrees with respect to the pendulum and should occur between 72 and 82 milliseconds after time-zero. The decaying head rotation versus time curve should cross the zero angle between 147 and 174 milliseconds after time-zero.

8.2.6.5 The moment about the Y-axis of the head, measured with respect to the occipital condyle's, should have a maximum value between -52.9 and -80.0 Nm and should occur between 65 and 79 milliseconds. The decaying moment versus time curve should first cross zero between 120 and 148 milliseconds after reaching its peak value.

8.3 Knee Impact Test

8.3.1 The components required for the knee impact test include:

- a) Knee assembly
- b) Knee cap.
- c) Knee flesh and skin assembly.
- d) Knee inserts.

8.3.2 The test fixture, as shown in fig.7, supports the knee and lower leg assembly rigidly. The impact probe mass is $5.0 \text{ kg} \pm 0.01 \text{ kg}$, including instrumentation, rigid attachments, and the lower 1/3 of the suspension cable mass. The diameter of the impacting face is $76.2 \text{ mm} \pm 0.25 \text{ mm}$ with an edge radius of 0.5 mm. Mount an accelerometer on the end opposite the impacting face, with its sensitive axis collinear to the longitudinal centerline of the test probe.

- 8.3.3 The data acquisition system, including transducers, must conform to the requirements of the latest revision of SAE Recommended Practice J211-1. Filter all data channels using Channel Class 600 phase less filters.
- 8.3.4 Test Procedure
- 8.3.4.1 Inspect the knee assembly for cracks, cuts, abrasions, etc. If the machined knee is cracked or broken in the impact area, replace the machined knee. If the insert is cut, replace the insert.
- 8.3.4.2 Mount the knee/lower leg assembly to the fixture using a femur load cell or load cell simulator. Torque the load cell simulator bolts to 40.7 Nm to prevent slippage of the assembly during the impact. When using the lower leg assembly, adjust the lower leg so the line between the knee and ankle pivots is at an angle of 66 degrees \pm 1 degree with the femur axis. Do not let the foot contact any exterior surface. The test setup is described in Figure 6.

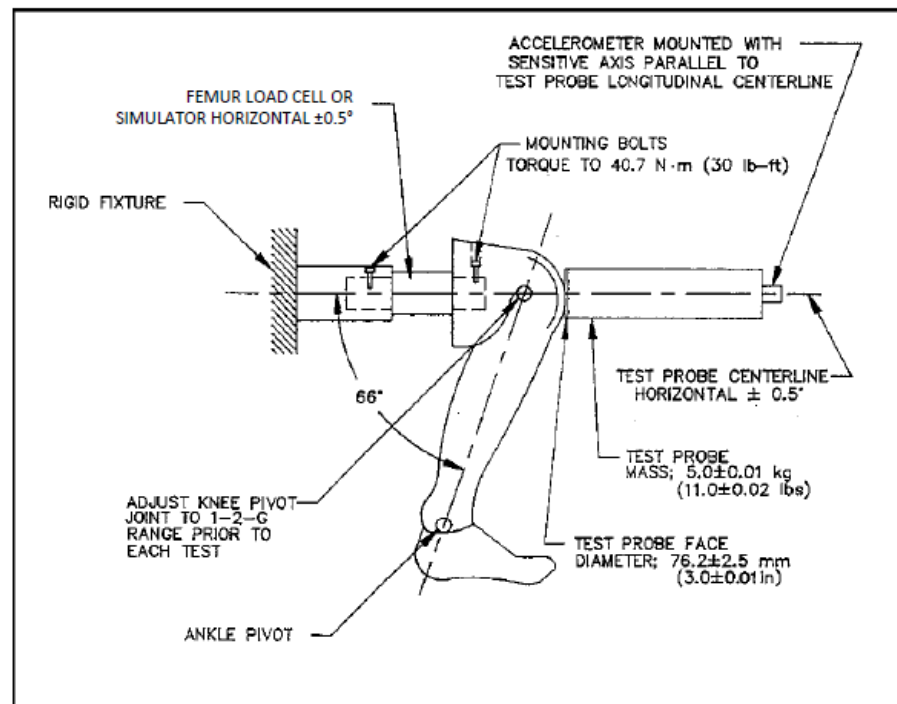

Fig 6: Knee impact test setup specifications

- 8.3.4.3 Align the longitudinal centerline of the test probe so it is collinear (within 2 degrees) with the longitudinal centerline of the load cell simulator at the time of impact.
- 8.3.4.4 Guide the probe such that no significant lateral, vertical or rotational movement at time-zero.
- 8.3.4.5 Time-zero is defined as the time of initial contact between the test probe face and the knee skin. All data channels should be at the zero level at this time.
- 8.3.4.6 Impact the knee so the longitudinal centerline of the test probe is within 0.5 degree of a horizontal line parallel to the load cell simulator at time-zero.

- 8.3.4.7 The test probe velocity at the time of the impact is 2.10 ± 0.03 m/s .
- 8.3.5 Performance Specifications:
- 8.3.5.1 The peak impact force (defined as the product of the test probe mass and the deceleration) should lie between 4715 and 5782 N.
- 8.4 **Knee Slider Test**
- 8.4.1 The components required for the knee slider test are:
- Knee assemblies with Displacement transducer.
 - Femur load cell.
- 8.4.2 The test fixture, as shown in fig. 7, consists of rigidly support to the knee assembly. The test probe mass is $12.00 \text{ kg} \pm 0.020 \text{ kg}$, including instrumentation, rigid attachments, and the lower 1/3 of the suspension cable mass. The diameter of the impacting face is $76.2 \text{ mm} \pm 0.3 \text{ mm}$ with an edge radius of 0.5 mm. A load distribution bracket is required to transmit the impact to the slider assembly, as shown in figure.
- 8.4.3 The data acquisition system, including transducers, must conform to the specifications of the latest revision of SAE Recommended Practice J211-1. Filter the displacement data channel using Channel Class 180 phaseless filters.

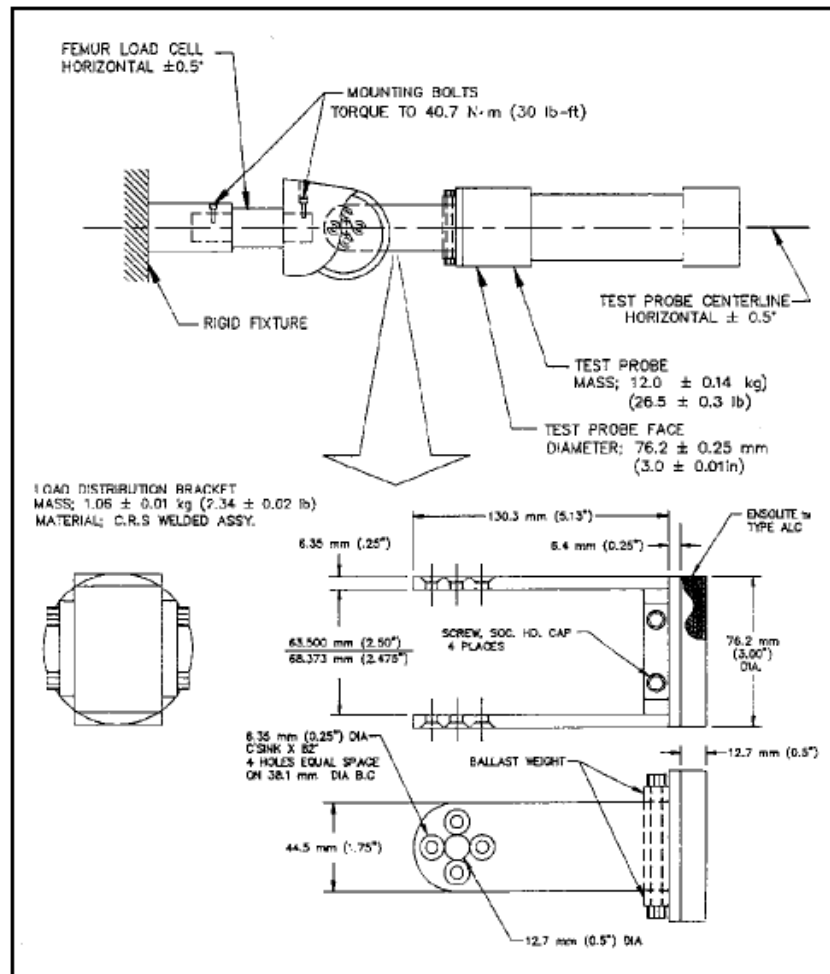

Fig 7: Knee slider test setup.

8.4.4 Test Procedure

- 8.4.4.1 Inspect the knee assembly for damage. Inspect the left and right side slider assemblies to ensure the tracks are clean and free from damage which could affect the operation. A pot pin should slide freely when the pot is installed.
 - 8.4.4.2 Check that all transducers are properly installed, oriented, and calibrated.
 - 8.4.4.3 Mount the knee assembly to the fixture using a femur load cell. Torque the 2 mounting bolts of the load cell to 40.7 Nm to prevent slippage of the assembly during impact.
 - 8.4.4.4 Attach the load distribution bracket to the slider assembly. The bracket is attached to the inboard and outboard slider assemblies in the same manner as the knee clevis, so the impacted bracket will slide rearward in the track.
 - 8.4.4.5 Align the longitudinal centerline of the test probe so at the time of impact, it is collinear (within 2 degrees) with the longitudinal centerline between the load cell and the load distribution bracket. The test probe longitudinal centerline should be horizontal 0.5 degree. The test setup is shown in Figure 8.
 - 8.4.4.6 Guide the probe so no significant lateral, vertical or rotational motion occurs at the time of contact between the test probe face and the load distribution bracket.
 - 8.4.4.7 The test probe velocity at the time of impact is $2.75 \text{ m/s} \pm 0.05 \text{ m/s}$.
 - 8.4.4.8 Time-zero is defined as the time of initial contact between the test probe and the load distribution bracket. All data channels should be at zero level at this time.
- 8.4.5 Performance Specifications
- 8.4.5.1 A plot of femur load versus knee slider deflection should be within the corridor described in Table 7.

Displacement	Femur Force (Minimum)	Femur Force Maximum
10.2 mm	1.26 kN	1.72 kN
17.8 mm	2.27 kN	3.10 kN

Table7: Force v/s displacement corridor for knee slider test.

8.5 Hip Joint Range of Motion Test

- 8.5.1 The test monitors the moment versus angle relationship of the upper femur and pelvis when each femur is rotated toward the pelvis.
- 8.5.2 The parts required for testing are:
 - a) Left and right upper femur assemblies.
 - b) Pelvis.

- 8.5.3 The test fixture consists of a structure to hold the pelvis and upper femur assembly, and a device to apply a moment through each upper femur. A generalized test set-up is shown in Figure 8. The fixture must be secured to prevent movement during the test. An adaptor mounted to the pelvis instrumentation cavity should mount the pelvis to the fixture and align it. The fixture should hold the pelvis so the bottom and rear skin of the pelvis do not contact the fixture. The fixture should hold the pelvis rigidly and prevent motion throughout the test. To ensure that the pelvis is restrained; an additional clamp to the fixture that is mounted through the 2 front bolt holes for the lumbar adaptor. The moment arm should extend straight out of the upper femurs and have a disk which has the same size and mass as that on the femur bone. The disk should also be in the same location relative to the upper femurs as it is on the femur bone. The fixture should compensate for the effect of the mass of the moment arm, or include the effect when determining the applied torque. A guiding system is required to keep the moment arm aligned throughout the test.
- 8.5.4 The Data Acquisition System, including transducers, must conform to the requirements of the latest version of SAE Recommended Practice J211-1. Filter the data with SAE Class 60 phaseless filters.
- 8.5.5 Test Procedure
- 8.5.5.1 Clean the inside and front flesh of the pelvis with isopropyl alcohol, or equivalent, before initial assembly.
- 8.5.5.2 Inspect the urethane stops for damage. Replace them if necessary. Inspect the pelvis flesh inside and outside the femur cavity for tears. If the pelvis flesh or foam is torn or disintegrated in this area, it should be replaced. Insert the urethane stops into the upper femurs. Apply a small amount of talcum powder to the pelvis flesh and urethane bumper, as a lubricant (to prevent tearing of the urethane bumper) and insert the upper femurs into the pelvis. Remove the instrument cavity cover and femur friction adjustment screws.

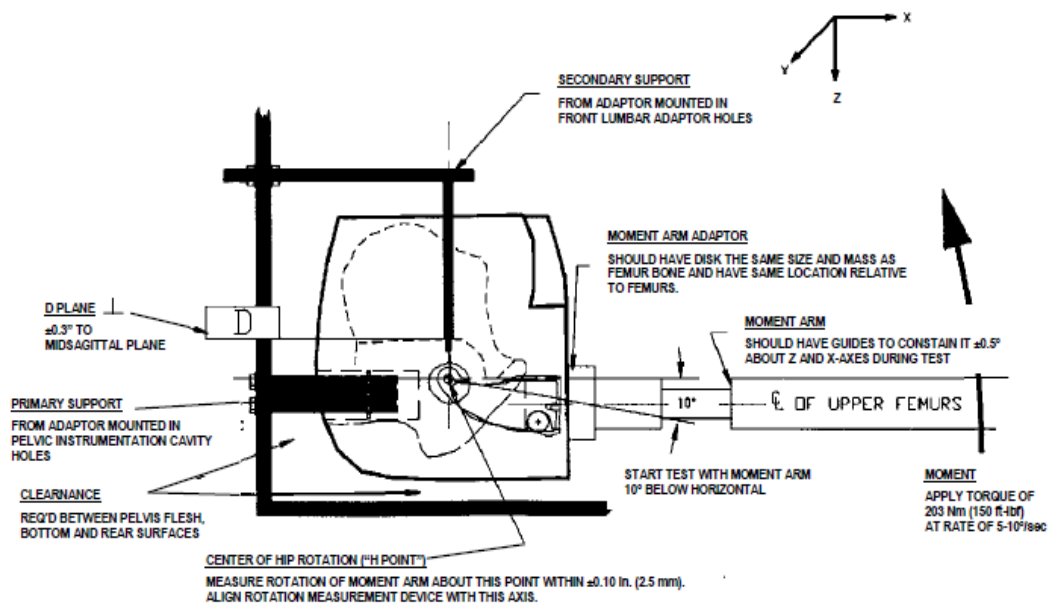

Fig 8: Hip joint range of motion calibration set up.

- 8.5.5.3 Mount the pelvis assembly on the fixture. Surface should be perpendicular to the mid sagittal plane within ± 0.3 degree.
- 8.5.5.4 Insert the moment arm into one of the upper femurs, and place the moment arm within the guiding system. The moment arm and upper femur should be parallel to the mid sagittal plane within ± 0.5 degree, initially and throughout the test. Initially, the moment arm should be positioned so the bolt connecting the moment arm to the femur is perpendicular to the mid sagittal plane within ± 0.5 degree. The guiding system should constrain the moment arm to prevent twist about the moment arm axis of more than ± 0.5 degree.
- 8.5.5.5 Install the moment and angle measuring transducers. All measurements should be taken relative to the D surface of the pelvis. The origin of the angle measurement should be located at the H-point within 2.5 mm as referenced on the drawing package. Marking of the H-point on the pelvis flesh, to use as a reference, is not sufficient for this test.
 - 8.5.5.5.1 Two rotary pots are used to measure the angles; one positioned at the H-point which acts as static reference and the other fixed to the moment arms at a known position; a rod connects the two rotary pots.
 - 8.5.5.5.2 The required torque is applied to the moment arm using pneumatic cylinder fitted with force transducer.
- 8.5.5.6 Time zero is defined as the point at which the moment arm is parallel to the D surface of the pelvis. All data channels should be at the zero level at this time after filtering. However, the test must begin at a location approximately 10 degrees below horizontal to eliminate any static friction effects and allow time to achieve the correct load rate.
- 8.5.5.7 Apply load to the loading arm until a torque of at least 203 Nm is achieved. The applied torque should not be significantly above this value to prevent damage to the pelvis flesh. The rate of rotation should be between 5 and 10 degrees/second.
- 8.5.5.8 Testing should be performed on each femur separately. Each femur should be tested with the moment arm parallel to the mid sagittal plane.
- 8.5.6 Performance Specifications
 - 8.5.6.1 The measured angle should be between 40 and 50 degrees, inclusive, at an applied torque of 203 Nm. In addition, the torque must remain below 95 Nm at angles up to 30 degrees.
- 8.6 **Thorax Impact Test**
 - 8.6.1.1 The complete dummy assembly, including the clothing [shirt and pants], but without the shoes is required for this test.
 - 8.6.1.2 The test set up consists of a smooth, clean, dry, steel seating surface and a test probe. The test probe mass is $23.36 \text{ kg} \pm 0.02 \text{ kg}$, including instrumentation, rigid attachments, and the lower 1/3 of the suspension cable mass. The diameter of the impacting face is $152.4 \text{ mm} \pm 0.25 \text{ mm}$ and has a flat, right angle face with an edge radius of $12.7 \text{ mm} \pm 0.3 \text{ mm}$. Mount

an accelerometer to the probe with its sensitive axis in line with the longitudinal centerline of the test probe.

- 8.6.1.3 The data acquisition system, including transducers, must conform to the specifications of the latest revision of SAE Recommended Practice J211-1. Filter all data channels using Channel Class 600 phaseless filters.
- 8.6.2 Test Procedure:
 - 8.6.2.1 Remove the chest flesh and visually inspect the thorax assembly for cracks, cuts, abrasions, etc. ensure correctness of the rib damping material, chest displacement transducer assembly, and the rear rib supports. Torque the 2 lumbar cables to 1.1 to 1.4 Nm.
 - 8.6.2.2 Soak the test dummy until the rib temperature has reached the soak temperature.
 - 8.6.2.3 Check that all transducers are properly installed, oriented, and calibrated.
 - 8.6.2.4 Sit the dummy (without the chest skin but with the pants) on the test fixture surface. The surface must be long enough to support the pelvis and outstretched legs.
 - 8.6.2.5 Align the upper and lower neck bracket index marks to the zero position.
 - 8.6.2.6 Place the arm assembly horizontal (± 2 degrees) and parallel to the mid sagittal plane. Secure the arms by tightening the adjustment nut which holds the arm yoke to the clavicle assembly. If necessary, prop the arms up with a rod that will fall away during the test.
 - 8.6.2.7 Level the ribs longitudinally and laterally within ± 0.5 degree and adjust the pelvis angle to 13 degrees ± 2 degrees. (Insert the special tool into the pelvic structure to determine the pelvis angle.)
 - 8.6.2.8 The mid sagittal plane of the dummy is within ± 1 degree to the vertical and within 2 degrees to the centerline of the test probe. The longitudinal centerline of the test probe is centered on the mid sagittal plane of the dummy within 3 mm ± 0.25 mm. Align the test probe so its longitudinal centerline is 12.7 mm ± 1 mm below the horizontal centerline of the No. 3 rib and is within 0.5 degree of a horizontal line in the dummy's mid sagittal plane.
 - 8.6.2.9 After completing the initial setup, record reference measurements from locations such as the rear surfaces of the thoracic spine and the lower neck bracket. These reference measurements are necessary to ensure that the dummy remains in the same position after installing the chest flesh. When using a cable-supported test probe, the dummy must be moved rearward from the test probe to account for the thickness of the chest flesh, so the probe will impact at the lowest point on its arc of travel. The test setup appears in Figure 9.

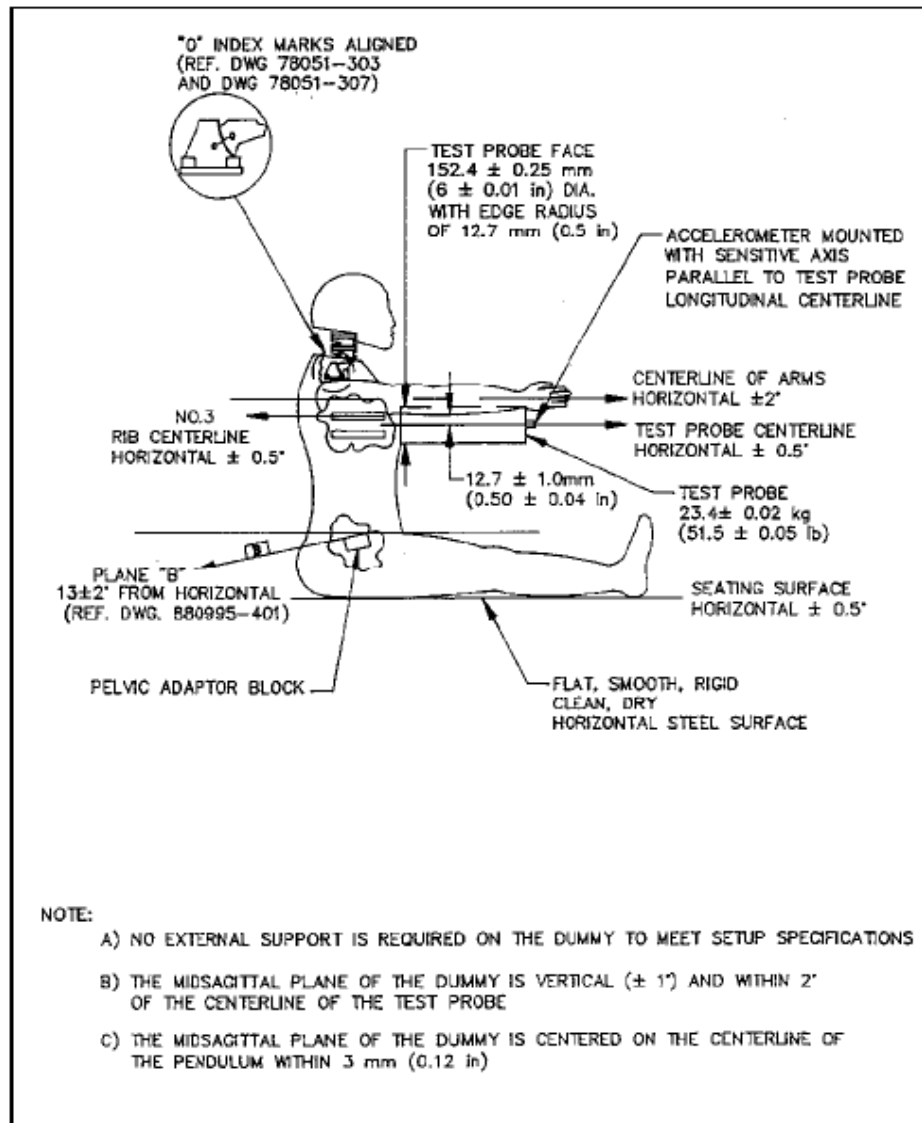

Fig 9: Thorax impact test set up.

- 8.6.2.10 Install the chest flesh and shirt. Reposition the dummy as described in the preceding paragraph using the recorded reference measurements. The reference locations must be accessible after installation of the chest flesh, so it may be necessary to leave the chest flesh unzipped until the references are checked, and then fasten it just prior to the test.
- 8.6.2.11 Impact the thorax with the test probe so the longitudinal centerline of the probe is within 2 degrees of a horizontal line in the mid sagittal plane of the dummy at the moment of impact.
- 8.6.2.12 Guide the probe such that no significant lateral, vertical or rotational motion takes place during the impact.
- 8.6.2.13 The test probe velocity at the time of impact is 6.71 m/s ± 0.12 m/s.
- 8.6.2.14 Time-zero is defined as the time of initial contact between the test probe and the chest flesh. All data channels should be at the zero level at this time.

8.6.3 Performance Specifications:

8.6.3.1 The maximum sternum-to-spine deflection, as measured by the chest displacement transducer, should be between 63.5 and 72.6 mm.

8.6.3.2 The maximum force applied to the thorax by the test probe should be between 5160 and 5894 N. The force is computed by multiplying the probe mass with the acceleration.

8.6.3.3 The internal hysteresis ratio of thorax should be within 69% and 85%. The hysteresis ratio, determined from the force versus deflection curve, is the ratio of the area between the loading and unloading portions of the curve to the area under the loading portion of the curve.

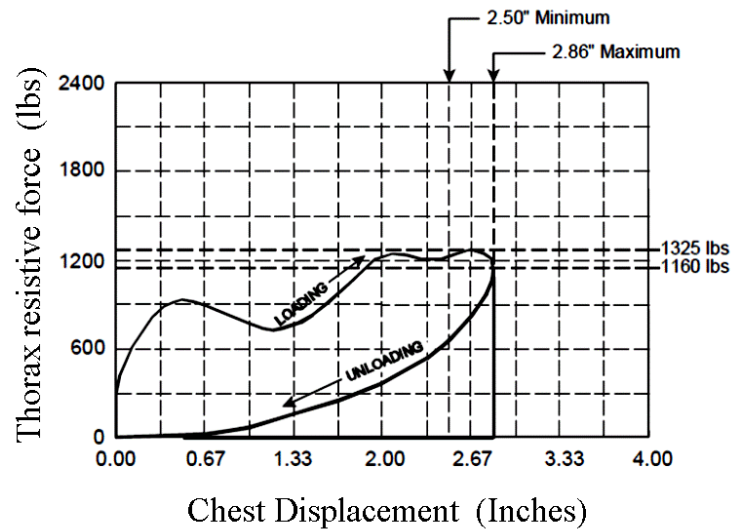

Fig 10: Thorax loading hysteresis graph.

22. Page No. 44/51, Annex 7,

Clause no. 1 (former) rename as Clause no. 8.7.

Clause no. 1.1. to 1.3. rename as Clause no. 8.7.1. to 8.7.3.

Delete Clause no. 1.3.1.(former) and Clause no. 1.3.2. to 1.3.4.(former) rename as Clause no. 8.7.3.1. to 8.7.3.4.

23. Page No. 45/51, Annex 7,

Clause no. 1.3.5. to 1.3.6. (former) rename as Clause no. 8.7.3.5. to 8.7.3.6.

Clause no. 1.4.(former) and 1.4.1.(former) rename as Clause no. 8.7.4. and 8.7.4.1.resp.

Clause nos. 2. (former), 2.1 to 2.3. (former) rename as Clause no. 8.8., 8.8.1. to 8.8.3.resp.

Delete Clause no. 2.3.1.(former) and Clause no. 2.3.2.(former) rename as Clause no. 8.8.3.1.

24. Page No. 46/51, Annex 7,

Clause no. 2.3.3. to 2.3.7. (former) rename as Clause no. 8.8.3.2. to 8.8.3.6.

Clause no. 2.4.(former) and 2.4.1.(former) rename as Clause no. 8.8.4. and 8.8.4.1.resp.

Clause no. 3.(former) and 3.1.(former) rename as Clause no. 8.9. and 8.9.1.resp.

25. Page No. 47/51, Annex 7,

Clause no. 3.2.to 3.3. (former) rename as Clause no. 8.9.2. to 8.9.3. resp.

Clause no. 3.3.1 (former) to be deleted.

Clause no. 3.3.2. to 3.3.7. (former) rename as Clause no. 8.9.3.1. and 8.9.3.6.resp.

26. Page No. 48/51, Annex 7,

Clause no. 3.4.(former) and 3.4.1.(former) rename as Clause no. 8.9.4. and 8.9.4.1.resp.

Substitute title “Figure 11” for “Figure 1”

27. Page No. 48/51, Annex 7,

Substitute title “Figure 12” for “Figure 2”

Substitute title “Figure 13” for “Figure 3”

28. Page No. 49/51, Annex 7,

Substitute title “Figure 14” for “Figure 4”

29. Page No. 51/51, Add new section “Annex 8” and substitute title “Annex 9” to “Annex 8”(former) as below:

ANNEX 8

(See 5.2.8.)

Test Procedures for the protection of the occupants of vehicles operating on electrical power from high voltage and electrolyte spillage

This annex describes test procedures to demonstrate compliance to the electrical safety requirements of paragraph 5.2.8. For example, megohmmeter or oscilloscope measurements are an appropriate alternative to the procedure described below for measuring isolation resistance. In this case it may be necessary to deactivate the on-board isolation resistance monitoring system.

Before the vehicle impact test conducted, the high voltage bus voltage (V_b) (see figure 1) shall be measured and recorded to confirm that it is within the operating voltage of the vehicle as specified by the vehicle manufacturer.

1. Test setup and equipment

If a high voltage disconnect function is used, measurements are to be taken from both sides of the device performing the disconnect function.

However, if the high voltage disconnect is integral to the REESS or the electrical energy conversion system and the high-voltage bus of the REESS or the electrical energy conversion system is protected according to protection degree IPXXB following the impact test, measurements may only be taken between the device performing the disconnect function and the electrical loads.

The voltmeter used in this test shall measure DC values and have an internal resistance of at least 10 M Ω .

2. The following instructions may be used if voltage is measured.

After the impact test, determine the high voltage bus voltages (V_b , V_1 , V_2) (see figure 1).

The voltage measurement shall be made not earlier than 5 seconds but not later than 60 seconds after the impact.

This procedure is not applicable if the test is performed under the condition where the electrical power train is not energized.

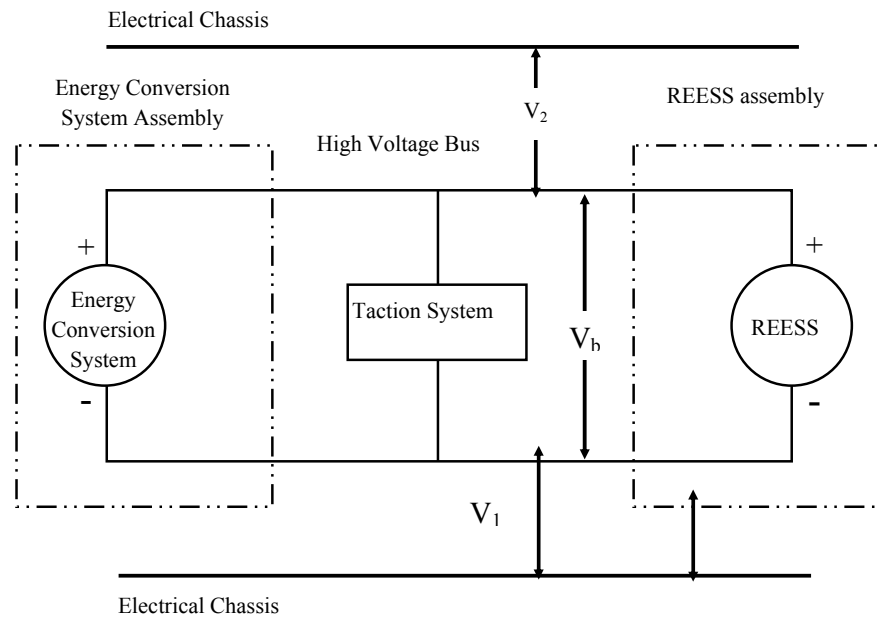

Figure 1 Measurement of V_b , V_1 , V_2

3. Assessment procedure for low electrical energy

Prior to the impact a switch S_1 and a known discharge resistor R_e is connected in parallel to the relevant capacitance (ref. figure 2).

Not earlier than 5 seconds and not later than 60 seconds after the impact the switch S_1 shall be closed while the voltage V_b and the current I_e are measured and recorded. The product of the voltage V_b and the current I_e shall be integrated over the period of time, starting from the moment when the switch S_1 is closed (t_c) until the voltage V_b falls below the high voltage threshold of 60 V DC (t_h). The resulting integration equals the total energy (TE) in J:

$$(a) \quad TE = \int_{t_c}^{t_h} V_b \times I_e dt$$

When V_b is measured at a point in time between 5 seconds and 60 seconds after the impact and the capacitance of the X-capacitors (C_x) is specified by the vehicle manufacturer, total energy (TE) shall be calculated according to the following formula:

$$(b) \quad TE = 0.5 \times C_x \times (V_b^2 - 3600)$$

When V_1, V_2 (see figure 1) are measured at a point in time between 5 seconds and 60 seconds after the impact and the capacitances of the Y-capacitors (C_{y1}, C_{y2}) are specified by the vehicle manufacturer, total energy (TE_{y1}, TE_{y2}) shall be calculated according to the following formulas:

$$(c) \quad TE_{y1} = 0.5 \times C_{y1} \times (V_1^2 - 3600)$$

$$TE_{y2} = 0.5 \times C_{y2} \times (V_2^2 - 3600)$$

This procedure is not applicable if the test is performed under the condition where the electrical power train is not energized.

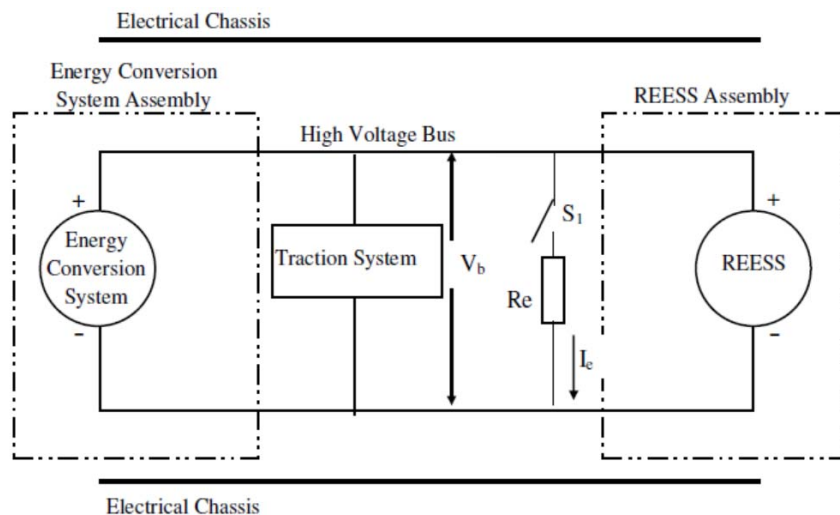

Figure 2 E.g. measurement of high voltage bus energy stored in X-capacitors

4. Physical protection

Following the vehicle impact test any parts surrounding the high voltage components shall be, without the use of tools, opened, disassembled or removed. All remaining surrounding parts shall be considered part of the physical protection.

The Jointed Test Finger described in Appendix 1 figure 1 shall be inserted into any gaps or openings of the physical protection with a test force of $10\text{ N} \pm 10\%$ for electrical safety assessment. If partial or full penetration into the physical protection by the Jointed Test Finger occurs, the Jointed Test Finger shall be placed in every position as specified below.

Starting from the straight position, both joints of the test finger shall be rotated progressively through an angle of up to 90 degrees with respect to the axis of the adjoining section of the finger and shall be placed in every possible position.

Internal barriers are considered part of the enclosure.

If appropriate a low-voltage supply (of not less than 40 V and not more than 50 V) in series with a suitable lamp should be connected, between the Jointed Test Finger and high voltage live parts inside the electrical protection barrier or enclosure.

4.1. Acceptance conditions

The requirements of paragraph 5.2.8.1.3. shall be considered to be met if the Jointed Test Finger described in Annex 8, Appendix 1, figure 1 is unable to contact high voltage live parts.

If necessary a mirror or a fiberscope may be used in order to inspect whether the Jointed Test Finger touches the high voltage buses.

If this requirement is verified by a signal circuit between the Jointed Test Finger and high voltage live parts, the lamp shall not light.

5. Isolation resistance

The isolation resistance between the high voltage bus and the electrical chassis may be demonstrated either by measurement or by a combination of measurement and calculation.

The following instructions should be used if the isolation resistance is demonstrated by measurement.

Measure and record the voltage (V_b) between the negative and the positive side of the high voltage bus (see figure 1):

Measure and record the voltage (V_1) between the negative side of the high voltage bus and the electrical chassis (see figure 1):

Measure and record the voltage (V_2) between the positive side of the high voltage bus and the electrical chassis (see figure 1):

If V_1 is greater than or equal to V_2 , insert a standard known resistance (R_o) between the negative side of the high voltage bus and the electrical chassis. With R_o installed, measure the voltage (V_1') between the negative side of the high voltage bus and the vehicle electrical chassis (see figure 3). Calculate the isolation resistance (R_i) according to the formula shown below.

$$R_i = R_o * (V_b / V_1' - V_b / V_1) \quad \text{or} \quad R_i = R_o * V_b * (1 / V_1' - 1 / V_1)$$

Divide R_i , which is the electrical isolation resistance value (in Ω) by the working voltage of the high voltage bus in volt (V).

$$R_i (\Omega / V) = R_i (\Omega) / \text{Working voltage (V)}$$

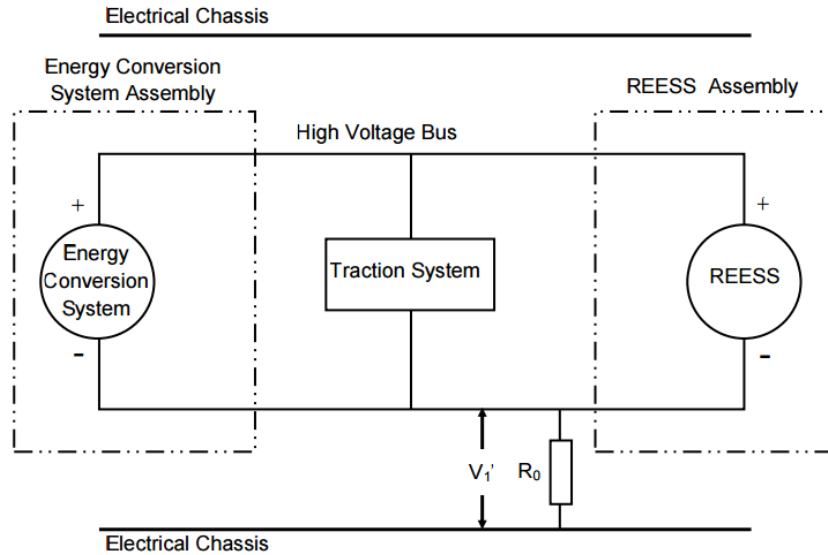

Figure 3 Measurement of V_1'

If $V_2 > V_1$, insert a standard known resistance (R_o) between the positive side of the high voltage bus and the electrical chassis. With R_o installed, measure the voltage (V_2') between the positive side of the high voltage bus and the electrical chassis (see figure 4).

Calculate the isolation resistance (R_i) according to the formula shown below.

$$R_i = R_o * (V_b / V_2' - V_b / V_2) \quad \text{or} \quad R_i = R_o * V_b * (1 / V_2' - 1 / V_2)$$

Divide R_i , which is the electrical isolation resistance value (in Ω) by the working voltage of the high voltage bus in volt (V).

$$R_i (\Omega / V) = R_i (\Omega) / \text{Working voltage (V)}$$

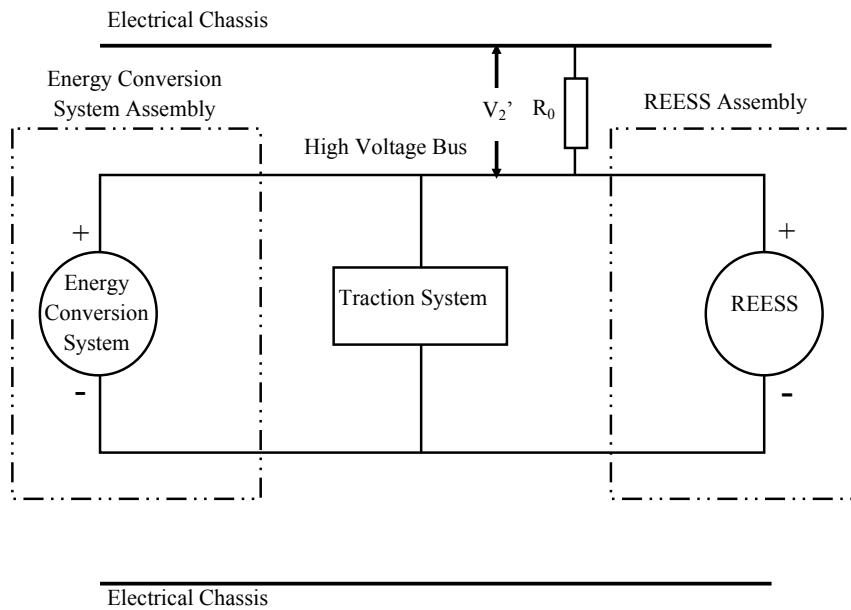

Figure 4 Measurement of V_2'

Note: The standard known resistance R_0 (Ω) should be the value of the minimum required isolation resistance (Ω /V) multiplied by the working voltage of the vehicle $\pm 20\%$. R_0 is not required to be precisely this value since the equations are valid for any R_0 ; however, an R_0 value in this range should provide a good resolution for the voltage measurements.

6. Electrolyte spillage

Appropriate coating shall be applied, if necessary, to the physical protection in order to confirm any electrolyte leakage from the REESS after the impact test.

Unless the vehicle manufacturer provides means to differentiate between the leakage of different liquids, all liquid leakage shall be considered as the electrolyte.

7. REESS retention

Compliance shall be determined by visual inspection.

Annex 8 – Appendix 1

(See 2.31)

Jointed Test Finger (Degree IPXXB)

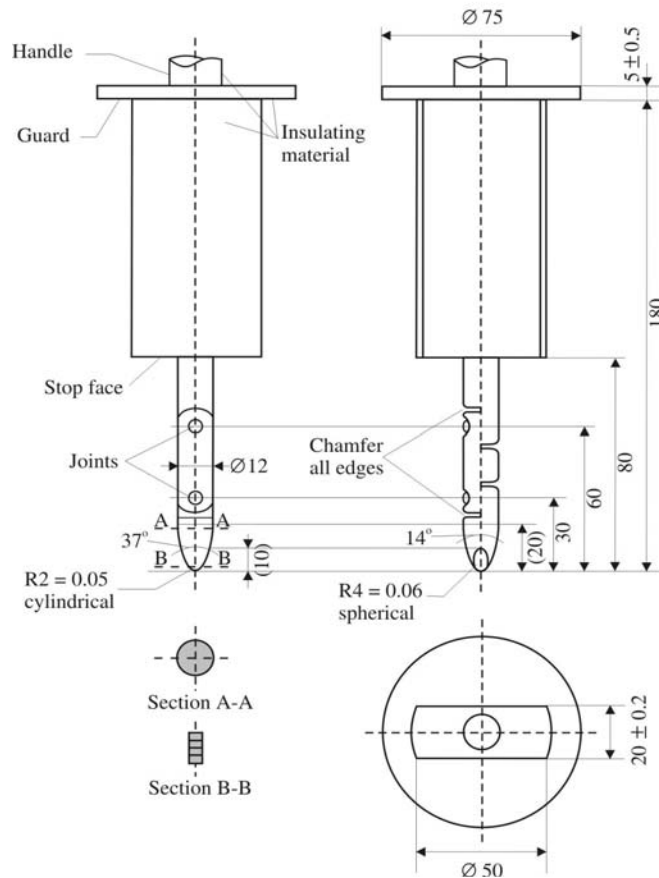

Figure 1 Jointed test finger

Material: metal, except where otherwise specified

Linear dimensions in millimeters

Tolerances on dimensions without specific tolerance:

- (a) On angles: $0/-10$ degrees
- (b) On linear dimensions: up to 25 mm: $0/-0.05$ mm over
25 mm: ± 0.2 mm

Both joints shall permit movement in the same plane and the same direction through an angle of 90° with a 0 to $+10^\circ$ tolerance.

PRINTED BY
THE AUTOMOTIVE RESEARCH ASSOCIATION OF INDIA
P.B. NO. 832, PUNE 411 004
ON BEHALF OF
AUTOMOTIVE INDUSTRY STANDARDS COMMITTEE
UNDER
CENTRAL MOTOR VEHICLE RULES – TECHNICAL STANDING
COMMITTEE
SET-UP BY
MINISTRY OF ROAD TRANSPORT & HIGHWAYS
(DEPARTMENT OF ROAD TRANSPORT & HIGHWAYS)
GOVERNMENT OF INDIA
15 December 2015

AUTOMOTIVE INDUSTRY STANDARD

**Requirements for the Protection
of the Occupants in the event of
an Offset Frontal Collision**

PRINTED BY
THE AUTOMOTIVE RESEARCH ASSOCIATION OF INDIA
P.B. NO. 832, PUNE 411 004

ON BEHALF OF
AUTOMOTIVE INDUSTRY STANDARDS COMMITTEE

UNDER
CENTRAL MOTOR VEHICLE RULES – TECHNICAL STANDING COMMITTEE

SET-UP BY
MINISTRY OF SHIPPING, ROAD TRANSPORT & HIGHWAYS
(DEPARTMENT OF ROAD TRANSPORT & HIGHWAYS)
GOVERNMENT OF INDIA

August 2008

Status chart of the Standard to be used by the purchaser for updating the record

Sr. No.	Corr-igenda.	Amend-ment	Revision	Date	Remark	Misc.
General remarks :						

INTRODUCTION

The Government of India felt the need for a permanent agency to expedite the publication of standards and development of test facilities in parallel when the work on the preparation of the standards is going on, as the development of improved safety critical parts can be undertaken only after the publication of the standard and commissioning of test facilities. To this end, the erstwhile Ministry of Surface Transport (MoST) has constituted a permanent Automotive Industry Standards Committee (AISC) vide order No. RT-11028/11/97-MVL dated September 15, 1997. The standards prepared by AISC will be approved by the permanent CMVR Technical Standing Committee (CTSC). After approval, the Automotive Research Association of India, (ARAI), Pune, being the secretariat of the AIS Committee, has published this standard.

Based on deliberations in the CMVR-TSC and AISC it has been decided to create a suite of standards related to Passive Safety which are founded on dynamic (or crash) testing of passenger cars and utility vehicles. These standards would then form the basis of the notification and implementation of advanced passive safety norms in the latter part of this decade as per the Safety Road Map adopted for India.

This is the second standard in the series of crash related test standards. This is an entirely new standard for Indian automotive field & applicable for M1 category vehicles with GVW less than 2500 kg. Vehicles upgraded to meet this standard would have achieved a higher level of occupant safety as road crashes of this category of vehicles all over the world are predominantly of offset frontal variety.

While preparing this AIS considerable assistance is derived from following international standards:

ECE R 94 (Supp. 2 to 01 Series of Amd.)	Uniform Provisions concerning the approval of vehicles with regard to the protection of the occupants in the event of frontal collision.
--	--

EEC Directive 96/79/EEC (March 2001):	Protection of occupants of motor vehicles in the event of a frontal impact.
---------------------------------------	---

The Automotive Industry Standards Committee responsible for preparation of this standard is given in Annex : 8

Requirements for the Protection of the Occupants in the event of an Offset Frontal Collision

0. SCOPE

- 0.1 This standard applies to vehicles of category M1 of a total permissible mass not exceeding 2.5 tonnes; heavier vehicles may be approved at the request of the manufacturer;
- 0.2 This standard shall not apply to multi-stage built vehicles produced in quantities not exceeding 500 vehicles in any period of 12 months duration.

1. REFERENCES

1.1	NHTSA TP-214D (Appendix C)	Aluminium Honeycomb Crush Strength Certification.
1.2	FMVSS (49CFR) Part 572, Sub part E, August 2004)	Anthropomorphic Test Devices, Hybrid III Test Dummy
1.3	FMVSS 208	Laboratory Test Procedure for Occupant Crash Protection.
1.4	AIS-097	Procedure for Determining the "H" Point and the Torso Angle for 50 th Percentile Adult Male in Seating Positions of Motor Vehicles
1.5	AIS-096	Requirements for Behavior of Steering Mechanism of a Vehicle in a Head on Collision
1.6	ISO 209 – Part 1	Wrought aluminium and aluminium alloys – chemical composition and forms of rods- Part 1 – chemical composition.

2. DEFINITIONS

For the purposes of this standard:

- 2.1 "**Protective system**" means interior fittings and devices intended to restrain the occupants and contribute towards ensuring compliance with the requirements set out in paragraph 5 below;
- 2.2 "**Type of protective system**" means a category of protective devices which do not differ in such essential respects as:
 - Their technology;
 - Their geometry;
 - Their constituent materials;

- 2.3 **"Vehicle width"** means the distance between two planes parallel to the longitudinal median plane (of the vehicle) and touching the vehicle on either side of the said plane but excluding the rear-view mirrors, side marker lamps, tyre pressure indicators, direction indicator lamps, position lamps, flexible mud-guards and the deflected part of the tyre side-walls immediately above the point of contact with the ground;
- 2.4 **"Overlap"** means the percentage of the vehicle width directly in line with the barrier face;
- 2.5 **"Deformable barrier face"** means a crushable section mounted on the front of a rigid block;
- 2.6 **"Vehicle type"** means a category of power-driven vehicles which do not differ in such essential respects as:
- 2.6.1 The length and width of the vehicle, in so far as they have a negative effect on the results of the impact test prescribed in this standard,
- 2.6.2 The structure, dimensions, lines and materials of the part of the vehicle forward of the transverse plane through the "R" point of the driver's seat, in so far as they have a negative effect on the results of the impact test prescribed in this standard,
- 2.6.3 The lines and inside dimensions of the passenger compartment and the type of protective system, in so far as they have a negative effect on the results of the impact test prescribed in this standard,
- 2.6.4 The siting (front, rear or centre) and the orientation (transversal or longitudinal) of the engine,
- 2.6.5 The unladen mass, in so far as there is a negative effect on the result of the impact test prescribed in this standard,
- 2.6.6 The optional arrangements or fittings provided by the manufacturer, in so far as they have a negative effect on the result of the impact test prescribed in this standard,
- 2.7 **"Passenger compartment"** means the space for occupant accommodation, bounded by the roof, floor, side walls, doors, outside glazing and front bulkhead and the plane of the rear compartment bulkhead or the plane of the rear-seat back support;
- 2.8 **"R point"** means a reference point defined for each seat by the manufacturer in relation the vehicle's structure, as indicated in AIS-097;
- 2.9 **"H point"** means a reference point determined for each seat by the testing agency responsible for approval, in accordance with the procedure described in AIS-097;

- 2.10. **"Unladen kerb mass"** means the mass of the vehicle in running order, unoccupied and unladen but complete with fuel, coolant, lubricant, tools and spare wheel (if these are provided as standard equipment by the vehicle manufacturer).
- 2.11. **"Airbag"** means a device installed to supplement safety belts and restraint systems in power-driven vehicles, i.e. systems which, in the event of a severe impact affecting the vehicle, automatically deploy a flexible structure intended to limit, by compression of the gas contained within it, the gravity of the contacts of one or more parts of the body of an occupant of the vehicle with the interior of the passenger compartment.
- 2.12. **"Passenger airbag"** means an airbag assembly intended to protect occupant(s) in seats other than the driver's in the event of a frontal collision.
- 2.13. **"Child restraint"** means an arrangement of components which may comprise a combination of straps or flexible components with a securing buckle, adjusting devices, attachments, and in some cases a supplementary chair and/or an impact shield, capable of being anchored to a power driven vehicle. It is so designed as to diminish the risk of injury to the wearer, in the event of a collision or of abrupt deceleration of the vehicle by limiting the mobility of the wearer's body.
- 2.14. **"Rearward-facing"** means facing in the direction opposite to the normal direction of travel of the vehicle.
- 2.15. (Reserved)
- 2.16. (Reserved)
- 2.17. (Reserved)
- 2.18. (Reserved)
- 2.19. (Reserved)
- 2.20. (Reserved).
- 2.21. **"Multi-stage build"** means the procedure whereby two or more manufacturers separately and sequentially participate in the construction of a vehicle.

3. APPLICATION FOR APPROVAL

- 3.1 The application for approval of a vehicle type with regard to the protection of the occupants of the front seats in the event of a offset frontal collision shall be submitted by the vehicle manufacturer or by his duly accredited representative.
- 3.2 It shall be accompanied by the under-mentioned documents with following particulars;

- 3.2.1 A detailed description of the vehicle type with respect to its structure, dimensions, lines and constituent materials;
- 3.2.2 Photographs, and/or diagrams and drawings of the vehicle showing the vehicle type in front, side and rear elevation and design details of the forward part of the structure;
- 3.2.3 Particulars of the vehicle's unladen kerb mass;
- 3.2.4 The lines and inside dimensions of the passenger compartment;
- 3.2.5 A description of the interior fittings and protective systems installed in the vehicle.
- 3.3 The applicant for approval shall be entitled to present any data and results of tests carried out which make it possible to establish that compliance with the requirements can be achieved with a sufficient degree of confidence.
- 3.4 A vehicle which is representative of the type to be approved shall be submitted to the testing agency responsible for conducting the approval tests.
 - 3.4.1 A vehicle not comprising all the components proper to the type may be accepted for test provided that it can be shown that the absence of the components omitted has no detrimental effect on the results of the test in so far as the requirements of this standard are concerned.
 - 3.4.2 It shall be the responsibility of the applicant for approval to show that the application of paragraph 3.4.1 is compatible with compliance with the requirements of this standard.

4. APPROVAL

- 4.1 If the vehicle type submitted for approval pursuant to this standard meets the requirements of this standard, approval of that vehicle type shall be granted.
 - 4.1.1 The testing agency appointed shall check whether the required conditions have been satisfied.
 - 4.1.2 In case of doubt, account shall be taken, when verifying the conformity of the vehicle to the requirements of this standard, of any data or test results provided by the manufacturer which can be taken into consideration in validating the approval test carried out by the testing agency.

5. SPECIFICATIONS

5.1. General specifications applicable to all tests

- 5.1.1. The "H" point for each seat shall be determined in accordance with the procedure described in AIS-097.
- 5.1.2. Vehicle to be tested shall be fitted with seat belts and seats conforming to the relevant notified standards of Central Motor Vehicle Rules, 1989.

5.2. Specifications

The test of the vehicle carried out in accordance with the method described in Annex 1 shall be considered satisfactory if all the conditions set out in paragraphs 5.2.1 to 5.2.6 below are all satisfied at the same time.

- 5.2.1 The performance criteria recorded, in accordance with Annex 5, on the dummies in the front outboard seats shall meet the following conditions:
 - 5.2.1.1 The head performance criterion (HPC) shall not exceed 1000 and the resultant head acceleration shall not exceed 80 g for more than 3 ms. The latter shall be calculated cumulatively, excluding rebound movement of the head;
 - 5.2.1.2 The neck injury criteria (NIC) shall not exceed the values shown in Figures 1 and 2

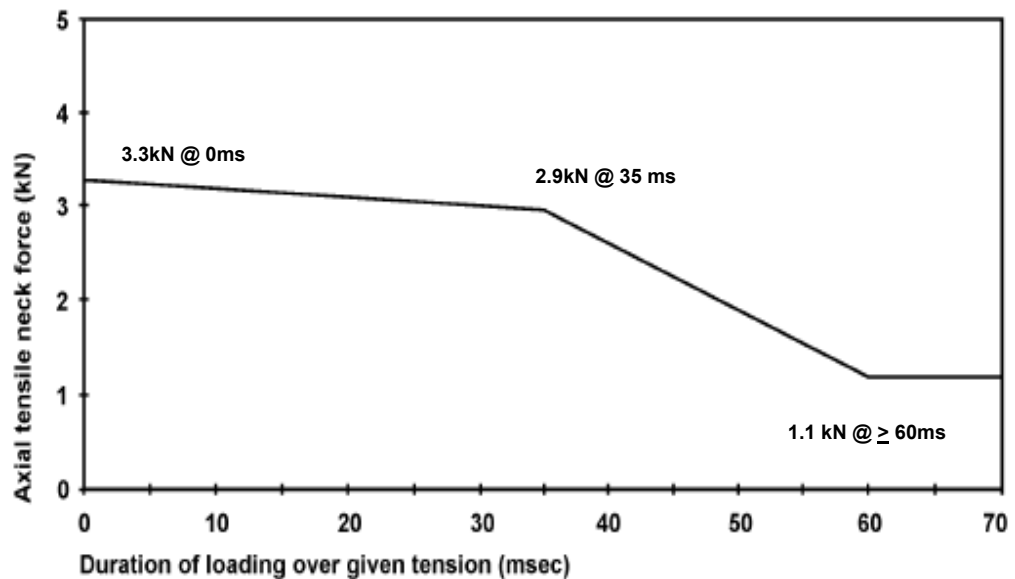

**Figure 1
Neck Tension Criteria**

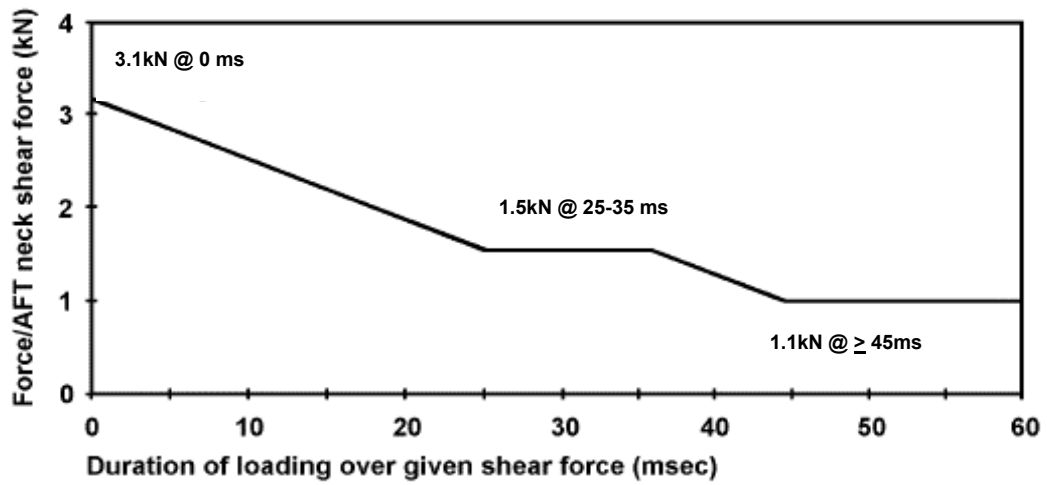

Figure 2
Neck Shear Criteria

- 5.2.1.3 The neck bending moment about the y axis shall not exceed 57 Nm in extension
- 5.2.1.4 The thorax compression criterion (ThCC) shall not exceed 50 mm;
- 5.2.1.5 The viscous criterion ($V * C$) for the thorax shall not exceed 1.0 m/s;
- 5.2.1.6 The femur force criterion (FFC) shall not exceed the force-time performance criterion shown in Figure 3;

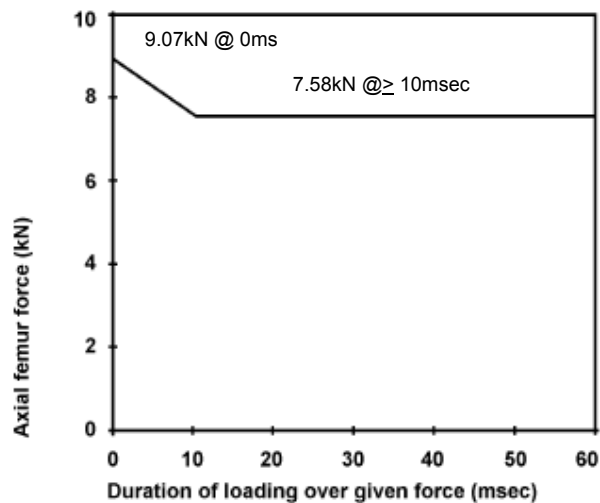

Figure 3
Femur Force Criteria

- 5.2.1.7 The tibia compression force criterion (TCFC) shall not exceed 8 kN;
- 5.2.1.8 The tibia index (TI), measured at the top and bottom of each tibia, shall not exceed 1.3 at either location;
- 5.2.1.9 The movement of the sliding knee joints shall not exceed 15 mm.
- 5.2.2 Residual steering wheel displacement, measured at the centre of the steering wheel hub, shall not exceed 80 mm in the upward vertical direction and 100 mm in the rearward horizontal direction.
- 5.2.3 During the test no door shall open;
- 5.2.4 During the test no locking of the locking systems of the front doors shall occur; however, vehicle models equipped with automatic door locking systems shall be tested with automatic locking system de-activated.
- 5.2.5 After the impact, it shall be possible, without the use of tools, except for those necessary to support the weight of the dummy:
 - 5.2.5.1 To open at least one door, if there is one, per row of seats and, where there is no such door, to move the seats or tilt their backrests as necessary to allow the evacuation of all the occupants; this is, however, only applicable to vehicles having a roof of rigid construction;
 - 5.2.5.2 To release the dummies from their restraint system which, if locked, shall be capable of being released by a maximum force of 60 N on the centre of the release control;
 - 5.2.5.3 To remove the dummies from the vehicle without adjustment of the seats.
- 5.2.6 In the case of a vehicle propelled by liquid fuel, no more than slight leakage of liquid from the fuel feed installation shall occur on collision;
- 5.2.7 If there is continuous leakage of liquid from the fuel-feed installation after the collision, the rate of leakage shall not exceed 30 g/min; if the liquid from the fuel-feed system mixes with liquids from the other systems and the various liquids cannot easily be separated and identified, all the liquids collected shall be taken into account in evaluating the continuous leakage.

6. INSTRUCTIONS FOR USERS OF VEHICLES EQUIPPED WITH AIRBAGS

- 6.1 The vehicles shall carry information to the effect that it is equipped with airbags for seats.

- 6.1.1 For a vehicle fitted with an airbag assembly intended to protect the driver, this information shall consist of the inscription "AIRBAG" located in the interior of the circumference of the steering wheel; this inscription shall be durably affixed and easily visible.
- 6.1.2 For a vehicle fitted with a passenger airbag intended to protect occupants other than the driver, this information shall consist of the warning label described in paragraph 6.2 below.
- 6.2 A vehicle fitted with one or more passenger frontal protection airbags shall carry information about the extreme hazard associated with the use of rearward-facing child restraints on seats equipped with airbag assemblies.
- 6.2.1 As a minimum, this information shall consist of a label containing a pictogram and text warning as indicated below.



The overall dimensions shall be 120 x 60 mm or the equivalent area, as a minimum.

The label shown above may be adapted in such a way that the layout differs from the example above; however, the text content shall meet the above prescriptions.

- 6.2.2 At the time of type approval, the text on the label shall be in Hindi or English.
- 6.2.3 In the case of a frontal protection airbag on the front passenger seat, the warning shall be durably affixed to each face of the passenger front sun visor in such a position that at least one warning on the sun visor is visible at all times, irrespective of the position of the sun visor.

Alternatively, one warning shall be on the visible face of the stowed sun visor and a second warning shall be on the roof behind the visor, so, at least one warning is visible at all times. The text size shall allow the label to be easily read by a normal sighted user seated on the seat concerned.

In the case of a frontal protection airbag for other seats in the vehicle, the warning shall be directly ahead of the relevant seat, and clearly visible at all times to someone installing a rear-facing child restraint on that seat. The text size shall allow the label to be easily read by a normal sighted user seated on the seat concerned.

This requirement does not apply to those seats equipped with a device which automatically deactivates the frontal protection airbag assembly when any rearward-facing child restraint is installed.

- 6.2.4 Detailed information, making reference to the warning, shall be contained in the owner's manual of the vehicle; as a minimum the following text in Hindi or English, shall include:

"Do not use a rearward facing child restraint on a seat protected by an airbag in front of it!"

The text shall be accompanied by an illustration of the warning to be found in the vehicle.

7. CRITERIA FOR EXTENSION OF TYPE APPROVALS

- 7.1 While examining any modification affecting the structure, number of seats, the interior trims or fitting, or the position of the vehicle controls; or of mechanical parts which might affect the energy absorbing capability of the front of the vehicle, the testing agency may :
- 7.1.1 consider that the modifications made are unlikely to have an appreciable adverse effect and that in any case the vehicle still complies with the requirements. For example, the following may be treated as modifications unlikely to have appreciable adverse effects :
- 7.1.1.1 Any change in the engine compartment layout resulting in increased gaps between parts ahead of the firewall on the driver's side.
- 7.1.1.2 Any change in the seating system, which moves the test seating position of the occupant rearward.
- 7.1.1.3 Decrease in the unladen kerb mass of the vehicle as defined in paragraph 2.10 of this standard.
- 7.1.1.4 Reduction in the fuel tank capacity.
- 7.1.1.5 Increase in the number of propeller shaft components

- 7.1.1.6 Decrease in strength of the steering wheel when subjected to the head impact test as per AIS-096.
- 7.1.1.7 Decrease in the road wheel disc diameter without change in the material specifications.
- 7.1.1.8 change in the top anchorage position in rearwards or upward directions.
- 7.1.1.9 addition of a rear sunroof to a front sunroof if there is no change in the size, shape & structure of the approved front sunroof,
- 7.1.1.10 change in the vehicle drivetrain execution from 4X4 to 4X2.

OR

- 7.1.2 require to carry out further tests among those described below according to the nature of the modifications –
 - 7.1.2.1 Any modification of the vehicle affecting the general form of the structure of the vehicle (including body type like hatchback /notchback/station wagon and type of drive like RHD/LHD) and/or any increase in mass greater than 8% which, in the judgment of the testing agency, would have a marked adverse influence on the results of the tests necessitates a repetition of the test as described in Annex 1.
 - 7.1.2.2 If the modifications concern only interior fittings, and if the increase in the unladen kerb mass of the vehicle, defined in paragraph 2.10 of this standard, is not more than 8% and if the number of front seats initially provided in the vehicle remains the same, the following will need to be carried out, if it has a marked adverse influence on the results on the tests, in the judgment of the testing agency,,:
 - 7.1.2.2.1 a partial test as defined by the testing agency in relation to the modifications made,
 - 7.1.2.2.2 A simplified test, on type approved & proposed configuration, as provided for in Annex 4. and / or
- 7.2 any modification resulting in increase in specified ride height of vehicles by more than 5% shall require a repetition of the test as described in Annex 1.
- 7.3 the following will require a repetition of test as described in Annex 1 or Annex 4 at the choice of the manufacturer. While establishing the compliance with test as per Annex 4, it is necessary to compare the results between type approved configuration & proposed configuration by subjecting both these configurations for the test as per Annex 4.

- 7.3.1 Any change in the seat structure, which will result in reduced forward excursion of the test dummy during the test.
- 7.3.2 Addition of safety equipments such as airbags or seat belts with pre-tensioner and load limiters.
- 7.4 any other parameter can be considered as criteria for extension of approval if it is mutually agreeable to the testing agency & the vehicle manufacturer,

ANNEX 1

(See 5.2)

TEST PROCEDURE**1. INSTALLATION AND PREPARATION OF THE VEHICLE****1.1. Testing Ground**

The test area shall be large enough to accommodate the run-up track, barrier and technical installations necessary for the test. The last part of the track, for at least 5 m before the barrier, shall be horizontal, flat and smooth.

1.2. Barrier

The front face of the barrier consists of a deformable structure as defined in Annex 6 of this standard. The front face of the deformable structure is perpendicular within $\pm 1^\circ$ to the direction of travel of the test vehicle. The barrier is secured to a mass of not less than 7×10^4 kg, the front face of which is vertical within $\pm 1^\circ$. The mass is anchored in the ground or placed on the ground with, if necessary, additional arresting devices to restrict its movement.

1.3. Orientation of the Barrier

The orientation of the barrier is such that the first contact of the vehicle with the barrier is on the steering-column side. Where there is a choice between carrying out the test with a right-hand or left-hand drive vehicle, the test shall be carried out with the less favorable hand of drive as determined by the testing agency responsible for the tests.

1.3.1. Alignment of the Vehicle to the Barrier

The vehicle shall overlap the barrier face by $40\% \pm 20$ mm.

1.4. State of Vehicle**1.4.1. General Specification**

The test vehicle shall be representative of the series production, shall include all the equipment normally fitted and shall be in normal running order. Some components may be replaced by equivalent masses where this substitution clearly has no noticeable effect on the results measured under paragraph 6.

1.4.2. Mass of Vehicle**1.4.2.1** For the test, the mass of the vehicle submitted shall be the unladen kerb mass;

- 1.4.2.2 The fuel tank shall be filled with water to mass equal to 90% of the mass of a full as specified by the manufacturer with a tolerance of $\pm 1\%$.
- 1.4.2.3 All the other systems (brake, cooling, etc) may be empty; in this case the mass of the liquids shall be carefully compensated.
- 1.4.2.4 If the mass of the measuring apparatus on board the vehicle exceeds the 25 kg allowed, it may be compensated by reductions which have no noticeable effect on the results measured under paragraph 6 below;
- 1.4.2.5 The mass of the measuring apparatus shall not change each axle reference load by more than 5%, each variation not exceeding 20 kg.
- 1.4.2.6 The mass of the vehicle resulting from the provisions of paragraph 1.4.2.1 above shall be indicated in the report.
- 1.4.3. Passenger Compartment Adjustments
 - 1.4.3.1. Position of steering wheel

The steering wheel, if adjustable, shall be placed in the normal position indicated by the manufacturer or, failing that, midway between the limits of its range(s) of adjustment. At the end of propelled travel, the steering wheel shall be left free, with its spokes in the position, which according to the manufacturer corresponds to straight-ahead travel of the vehicle.
 - 1.4.3.2. Glazing

The movable glazing of the vehicle shall be in the closed position. For test measurement purposes and in agreement with the manufacturer, it may be lowered, provided that the position of the operating handle corresponds to the closed position.
 - 1.4.3.3. Gear-change lever

The gear-change lever shall be in the neutral position.
 - 1.4.3.4. Pedals

The pedals shall be in their normal position of rest. If adjustable, they shall be set in their mid position unless another position is specified by the manufacturer.
 - 1.4.3.5. Doors

The doors shall be closed but not locked. Vehicle models equipped with Automatic door locking systems shall be tested with Automatic locking system de-activated.
 - 1.4.3.6. Opening roof

If an opening or removable roof is fitted, it shall be in place and in the closed position. For test measurement purposes and in agreement with the manufacturer, it may be open.

- 1.4.3.7. Sun-visor
The sun-visors shall be in the stowed position.
- 1.4.3.8. Rear-view mirror
The interior rear-view mirror shall be in the normal position of use.
- 1.4.3.9. Arm-rests
Arm-rests at the front and rear, if movable, shall be in the lowered position, unless this is prevented by the position of the dummies in the vehicles.
- 1.4.3.10. Head restraints
Head restraints adjustable for height shall be in their uppermost position.
- 1.4.3.11. Seats
- 1.4.3.11.1. Position of front seats
Seats adjustable longitudinally shall be placed so that their "H" point, determined in accordance with the procedure set out in AIS097 is in the middle position of travel or in the nearest locking position thereto, and at the height position defined by the manufacturer (if independently adjustable for height). In the case of a bench seat, the reference shall be to the "H" point of the driver's place.
- 1.4.3.11.2. Position of the front seat-backs
If adjustable, the seat-backs shall be adjusted so that the resulting inclination of the torso of the dummy is as close as possible to that recommended by the manufacturer for normal use or, in the absence of any particular recommendation by the manufacturer, to 25° towards the rear from the vertical.
- 1.4.3.11.3. Rear seats
If adjustable, the rear seats or rear bench seats shall be placed in the rearmost position.

2. **DUMMIES**

2.1. **Front Seats**

- 2.1.1 A dummy complying with the requirements of Hybrid III ⁽¹⁾ as specified in FMVSS (49CFR) Part 572, Sub part E and fitted with a 45° ankle and meeting the specifications for its adjustment shall be installed in each of the front outboard seats in accordance with the conditions set out in Annex 5.

⁽¹⁾ The technical specifications and detailed drawings of Hybrid III, corresponding to the principal dimensions of a 50th percentile male of the United states of America, and the specifications for its adjustment for this test are deposited with the Secretary- General of the United Nations and may be consulted on request at the secretariat of the Economic Commission for Europe, Palais des Nations, Geneva, Switzerland.

The ankle of the dummy shall be certified in accordance with the procedures in Annex 7

- 2.1.1.1. However at the choice of the vehicle manufacturer, the lower foot calibration test can be demonstrated either in without shoe condition (paragraph 2 of Annex 7) or in with shoe condition (paragraph 3 of Annex 7).
- 2.1.2 The car will be tested with restraint systems, as provided by the manufacturer.

3. PROPULSION AND COURSE OF VEHICLE

- 3.1. The vehicle shall be propelled either by its own engine or by any other propelling device.
- 3.2. At the moment of impact the vehicle shall no longer be subject to the action of any additional steering or propelling device;
- 3.3. The course of the vehicle shall be such that it satisfies the requirements of paragraphs 1.2 and 1.3.1.

4. TEST SPEED

Vehicle speed at the moment of impact shall be 56 -0/+1 km/h. However, if the test was performed at a higher impact speed and the vehicle met the requirements, the test shall be considered satisfactory.

5. MEASUREMENTS TO BE MADE ON DUMMY IN FRONT SEATS

- 5.1. All the measurements necessary for the verification of the performance criteria shall be made with measurement systems corresponding to the specifications of Annex 5.
- 5.2. The different parameters shall be recorded through independent data channels of the following CFC (Channel Frequency Class):
 - 5.2.1. Measurements in the Head of the Dummy

The acceleration (a) referring to the centre of gravity is calculated from the triaxial components of the acceleration measured with a CFC of 1000.
 - 5.2.2. Measurements in the Neck of the Dummy
 - 5.2.2.1. The axial tensile force and the fore/aft shear force at the neck/head interface are measured with a CFC of 1000.

- 5.2.2.2. The bending moment about a lateral axis at the neck/head interface are measured with a CFC of 600.
- 5.2.3. Measurements in the Thorax of the Dummy

The chest deflection between the sternum and the spine is measured with a CFC of 180.
- 5.2.4. Measurements in the Femur and Tibia of the Dummy
 - 5.2.4.1. The axial compressive force and the bending moments are measured with a CFC of 600.
 - 5.2.4.2. The displacement of the tibia with respect to the femur is measured at the knee sliding joint with a CFC of 180.

6. MEASUREMENTS TO BE MADE ON THE VEHICLE

- 6.1. To enable the simplified test described in Annex 4 to be carried out, the deceleration time history of the structure shall be determined on the basis of the value of the longitudinal accelerometers at the base of the "B" pillar on the struck side of the vehicle with a CFC of 180 by means of data channels corresponding to the requirements set out in Annex 5;
- 6.2. The speed time history which will be used in the test procedure described in Annex 4 shall be obtained from the longitudinal accelerometer at the "B" pillar on the struck side.

ANNEX 2

DETERMINATION OF PERFORMANCE CRITERIA

1. HEAD PERFORMANCE CRITERION (HPC)

- 1.1. This criterion is considered to be satisfied when, during the test, there is no contact between the head and any vehicle component.
- 1.2. If that is not the case, a calculation of the value of HPC is made, on the basis of the acceleration (a), measured according to paragraph 5.2.1. of Annex 1, by the following expression:

$$\text{HPC} = (t_2 - t_1) \left[\frac{1}{t_2 - t_1} \int_{t_1}^{t_2} a dt \right]^{2.5}$$

in which:

- 1.2.1. The term 'a' is the resultant acceleration measured according to paragraph 5.2.1. of Annex 1 and is measured in units of gravity, g (1 g = 9.81 m/s²);
- 1.2.2. If the beginning of the head contact can be determined satisfactorily, t₁ and t₂ are the two time instants, expressed in seconds, defining an interval between the beginning of the head contact and the end of the recording for which the value of HPC is maximum;
- 1.2.3. If the beginning of the head contact cannot be determined, t₁ and t₂ are the two time instants, expressed in seconds, defining a time interval between the beginning and the end of the recording for which the value of HPC is maximum.
- 1.2.4. Values of HPC for which the time interval (t₁ and t₂) is greater than 36 ms are ignored for the purposes of calculating the maximum value.
- 1.3. The value of the resultant head acceleration during forward impact which is exceeded for 3 ms cumulatively is calculated from the resultant head acceleration measured according to paragraph 5.2.1 of Annex 1.

2. NECK INJURY CRITERIA (NIC)

- 2.1. These criteria are determined by the compressive axial force, the axial tensile force and the fore/aft shear forces at the head/neck interface, expressed in kN and measured according to paragraph 5.2.2 of Annex 1 and by the duration of these forces expressed in ms.
- 2.2. The neck bending moment criterion is determined by the bending moment, expressed in Nm, about a lateral axis at the head/neck interface and measured according to paragraph 5.2.2 of Annex 1.
- 2.3. The neck flexion bending moment, expressed in Nm, shall be recorded.

3. THORAX COMPRESSION CRITERION (ThCC) AND VISCOUS CRITERION (V * C)

- 3.1. The thorax compression criterion is determined by the absolute value of the thorax deformation, expressed in mm and measured according to paragraph 5.2.3 of Annex 1.
- 3.2. The viscous criterion (V * C) is calculated as the instantaneous product of the compression and the rate of deflection of the sternum, measured according to paragraph 6 and also paragraph 5.2.3 of Annex 1.

4. FEMUR FORCE CRITERION (FFC)

- 4.1. This criterion is determined by the compression load expressed in kN, transmitted axially on each femur of the dummy and measured according to paragraph 5.2.4 of Annex 1 and by the duration of the compressive load expressed in ms.

5. TIBIA COMPRESSIVE FORCE CRITERION (TCFC) AND TIBIA INDEX (TI)

- 5.1. The tibia compressive force criterion is determined by the compressive load (Fz) expressed in kN, transmitted axially on each tibia of the dummy and measured according to paragraph 5.2.4 of Annex 1.
- 5.2. The tibia index is calculated on the basis of the bending moments (Mx and My) measured according to paragraph 5.1. by the following expression:

$$TI = \left| M_R / (M_C)_R \right| + \left| F_Z / (F_C)_Z \right|$$

where:

- M_X = bending moment about the x axis
- M_Y = bending moment about the y axis
- $(M_C)_R$ = critical bending moment and shall be taken to be 225 Nm
- F_Z = compressive axial force in the z direction
- $(F_C)_Z$ = critical compressive force in the z direction and shall be taken to be 35.9 kN and

$$M_R = \sqrt{(M_X)^2 + (M_Y)^2}$$

The tibia index is calculated for the top and the bottom of each tibia; however, F_Z may be measured at either location. The value obtained is used for the top and bottom TI calculations. Moments M_X and M_Y are both measured separately at both locations.

6. PROCEDURE FOR CALCULATING THE VISCOUS CRITERIA (V * C) FOR HYBRID III DUMMY

- 6.1. The viscous criterion is calculated as the instantaneous product of the compression and the rate of deflection of the sternum. Both are derived from the measurement of sternum deflection.
- 6.2. The sternum deflection response is filtered once at CFC 180. The compression at time t is calculated from this filtered signal as:

$$C_{(t)} = \frac{D_{(t)}}{0.229}$$

The sternum deflection velocity at time t is calculated from the filtered deflection as:

$$V_{(t)} = \frac{8 (D_{(t+1)} - D_{(t-1)}) - (D_{(t+2)} - D_{(t-2)})}{12 \delta t}$$

where $D_{(t)}$ is the deflection at time t in metres and δt is the time interval in seconds between the measurements of deflection. The maximum value of δt shall be 1.25×10^{-4} seconds. This calculation procedure is shown diagrammatically below:

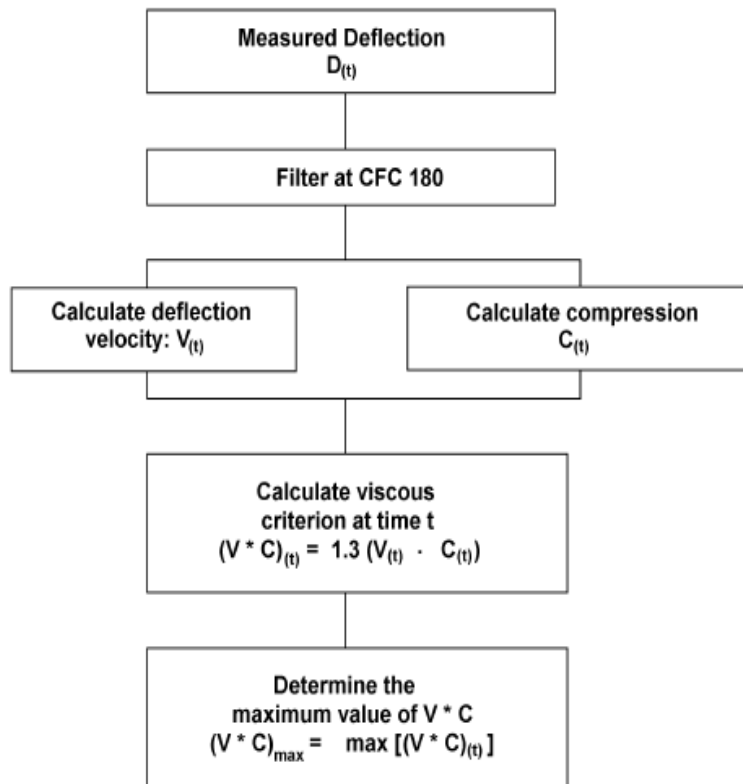

ANNEX 3

(See Annex 7- 3.2)

**ARRANGEMENT AND INSTALLATION OF DUMMIES AND
ADJUSTMENT OF RESTRAINT SYSTEMS****1. ARRANGEMENT OF DUMMIES****1.1. Separate Seats**

The plane of symmetry of the dummy shall coincide with the vertical median plane of the seat.

1.2. Front Bench Seat**1.2.1. Driver**

The plane of symmetry of the dummy shall lie in the vertical plane passing through the steering wheel centre and parallel to the longitudinal median plane of the vehicle. If the seating position is determined by the shape of the bench, such seat shall be regarded as a separate seat.

1.2.2. Outer Passenger

The plane of symmetry of the dummy shall be symmetrical with that of the driver dummy relative to the longitudinal median plane of the vehicle. If the seating position is determined by the shape of the bench, such seat shall be regarded as a separate seat.

1.3. Bench Seat for Front Passengers (not including driver)

The planes of symmetry of the dummy shall coincide with the median planes of the seating positions defined by the manufacturer.

2. INSTALLATION OF DUMMIES**2.1. Head**

The transverse instrumentation platform of the head shall be horizontal within 2.5°. To level the head of the test dummy in vehicles with upright seats with non-adjustable backs, the following sequences shall be followed. First adjust the position of the "H" point within the limits set forth in paragraph 2.4.3.1 below to level the transverse instrumentation platform of the head of the test dummy. If the transverse instrumentation platform of the head is still not level, then adjust the pelvic angle of the test dummy within the limits provided in paragraph 2.4.3.2 below. If the transverse instrumentation platform of the head is still not level, then adjust the neck bracket of the test dummy the minimum amount necessary to ensure that the transverse instrumentation platform of the head is horizontal within 2.5°.

2.2. Arms

- 2.2.1. The driver's upper arms shall be adjacent to the torso with the centerlines as close to a vertical plane as possible.
- 2.2.2. The passenger's upper arms shall be in contact with the seat back and the sides of the torso.

2.3. Hands

- 2.3.1. The palms of the driver test dummy shall be in contact with the outer part of the steering wheel rim at the rim's horizontal centreline. The thumbs shall be over the steering wheel rim and shall be lightly taped to the steering wheel rim so that if the hand of the test dummy is pushed upward by a force of not less than 9 N and not more than 22 N, the tape shall release the hand from the steering wheel rim.
- 2.3.2. The palms of the passenger test dummy shall be in contact with outside of thigh. The little finger shall be in contact with the seat cushion.

2.4. Torso

- 2.4.1. In vehicles equipped with bench seats, the upper torso of the driver and passenger test dummies shall rest against the seat back. The midsagittal plane of the driver dummy shall be vertical and parallel to the vehicle's longitudinal centreline, and pass through the centre of the steering wheel rim. The midsagittal plane of the passenger dummy shall be vertical and parallel to the vehicle's longitudinal centreline and the same distance from the vehicle's longitudinal centreline as the midsagittal plane of the driver dummy.
- 2.4.2. In vehicles equipped with individual seat(s), the upper torso of the driver and passenger test dummies shall rest against the seat back. The midsagittal plane of the driver and the passenger dummy shall be vertical and shall coincide with the longitudinal centreline of the individual seat.
- 2.4.3. Lower Torso
 - 2.4.3.1. "H" point

The "H" point of the driver and passenger test dummies shall coincide within 13 mm in the vertical dimension and 13 mm in the horizontal dimension, with a point 6 mm below the position of the "H" point determined using the procedure described in AIS 097 except that the length of the lower leg and thigh segments of the "H" point machine shall be adjusted to 414 and 401 mm, instead of 432 and 417 mm respectively.

2.4.3.2. Pelvic angle

As determined using the pelvic angle gauge (GM) drawing 78051-532 incorporated by reference in Part 572 which is inserted into the "H" point gauging hole of the dummy, the angle measured from the horizontal on the 76.2 mm (3 inch) flat surface of the gauge shall be 22 1/2 degrees plus or minus 2 1/2 degrees.

2.5. Legs

The upper legs of the driver and passenger test dummies shall rest against the seat cushion to the extent permitted by placement of the feet. The initial distance between the outboard knee clevis flange surface shall be 270mm \pm 10 mm. To the extent practicable, the left leg of the driver dummy and both legs of the passenger dummy shall be in vertical longitudinal planes. To the extent practicable, the right leg of the driver dummy shall be in a vertical plane. Final adjustment to accommodate placement of feet in accordance with paragraph 2.6 for various passenger compartment configurations is permitted.

2.6. Feet

- 2.6.1. The right foot of the driver test dummy shall rest on the undepressed accelerator with the rearmost point of the heel on the floor surface in the plane of the pedal. If the foot cannot be placed on the accelerator pedal, it shall be positioned perpendicular to the tibia and placed as far forward as possible in the direction of the centreline of the pedal with the rearmost point of the heel resting on the floor surface. The heel of the left foot shall be placed as far forward as possible and shall rest on the floor pan. The left foot shall be positioned as flat as possible on the toe-board. The longitudinal centreline of the left foot shall be placed as parallel as possible to the longitudinal centreline of the vehicle.
- 2.6.2. The heels of both feet of the passenger test dummy shall be placed as far forward as possible and shall rest on the floor pan. Both feet shall be positioned as flat as possible on the toe-board. The longitudinal centreline of the feet shall be placed as parallel as possible to the longitudinal centreline of the vehicle.
- 2.7. The measuring instruments installed shall not in any way affect the movement of the dummy during impact.
- 2.8. The temperature of the dummies and the system of measuring instruments shall be stabilised before the test and maintained so far as possible within- a range between 19 °C and 22 °C.

2.9. **Dummy Clothing**

- 2.9.1. The instrumented dummies will be clothed in formfitting cotton stretch garments with short sleeves and mid-calf length trousers specified in FMVSS 208, drawings 78051-292 and 293 or their equivalent.
- 2.9.2. A size 11XW shoe, which meets the configuration size, sole and heel thickness specifications of the US military standard MIL S 13192, revision P and whose weight is 0.57 ± 0.1 kg, shall be placed and fastened on each foot of the test dummies.

3. **ADJUSTMENT OF RESTRAINT SYSTEM**

With the test dummy at its designated seating position as specified by the appropriate requirements of paragraphs 2.1, through 2.6., place the belt around the test dummy and fasten the latch. Remove all slack from the lap belt. Pull the upper torso webbing out of the retractor and allow it to retract. Repeat this operation four times. Apply a 9 to 18 N tension load to the lap belt. If the belt system is equipped with a tension-relieving device, introduce the maximum amount of slack into the upper torso belt that is recommended by the manufacturer for normal use in the owner's manual for the vehicle. If the belt system is not equipped with a tension-relieving device, allow the excess webbing in the shoulder belt to be retracted by the retractive force of the retractor.

ANNEX 4

(See 7.1.2.2.2)

TEST PROCEDURE WITH TROLLEY**1. TEST INSTALLATION AND PROCEDURE****1.1. Trolley**

The trolley shall be so constructed that no permanent deformation appears after the test. It shall be so guided that, during the impact phase, the deviation in the vertical plane does not exceed 5° and 2° in the horizontal plane.

1.2. State of the Structure**1.2.1. General**

The structure tested shall be representative of the series production of the vehicles concerned. Some components may be replaced or removed where such replacement or removal clearly has no effect on the test results.

1.2.2. Adjustments

Adjustments shall conform to those set out in paragraph 1.4.3. of Annex 1 to this standard, taking into account what is stated in paragraph 1.2.1.

1.3. Attachment of the Structure

1.3.1. The structure shall be firmly attached to the trolley in such a way that no relative displacement occurs during the test.

1.3.2. The method used to fasten the structure to the trolley shall not have the effect of strengthening the seat anchorages or restraint devices, or of producing any abnormal deformation of the structure.

1.3.3. The attachment device recommended is that whereby the structure rests on supports placed approximately in the axis of the wheels or, if possible, whereby the structure is secured to the trolley by the fastenings of the suspension system.

1.3.4. The angle between the longitudinal axis of the vehicle and the direction of motion of the trolley shall be $0^\circ \pm 2^\circ$.

1.4. Dummies

The dummies and their positioning shall conform to the specifications in Annex 1, paragraph 2.

1.5. Measuring Apparatus**1.5.1. Deceleration of the Structure**

The position of the transducers measuring the deceleration of the structure during the impact shall be parallel to the longitudinal axis of the trolley according to the specifications of Annex 5 (CFC 180).

1.5.2. Measurements to be Made on the Dummies

All the measurements necessary for checking the listed criteria are set out in Annex 1, paragraph 5.

1.6. Deceleration Curve of the Structure

The deceleration curve of the structure during the impact phase shall be such that the "variation of speed in relation to time" curve obtained by integration at no point differs by more than ± 1 m/s from the "variation of speed in relation to time" reference curve of the vehicle concerned as defined in appendix to this Annex. A displacement with regard to the time axis of the reference curve may be used to obtain the structure velocity inside the corridor.

1.7. Reference Curve $DV = f(t)$ of the Vehicle Concerned

This reference curve is obtained by integration of the deceleration curve of the vehicle concerned measured in the frontal collision test against a barrier as provided for in paragraph 6 of Annex 1 to this standard.

1.8. Equivalent Method

The test may be performed by some other method than that of deceleration of a trolley, provided that such method complies with the requirement concerning the range of variation of speed described in paragraph 1.6.

ANNEX 4 – APPENDIX

EQUIVALENCE CURVE - TOLERANCE BAND FOR CURVE $DV = f(t)$

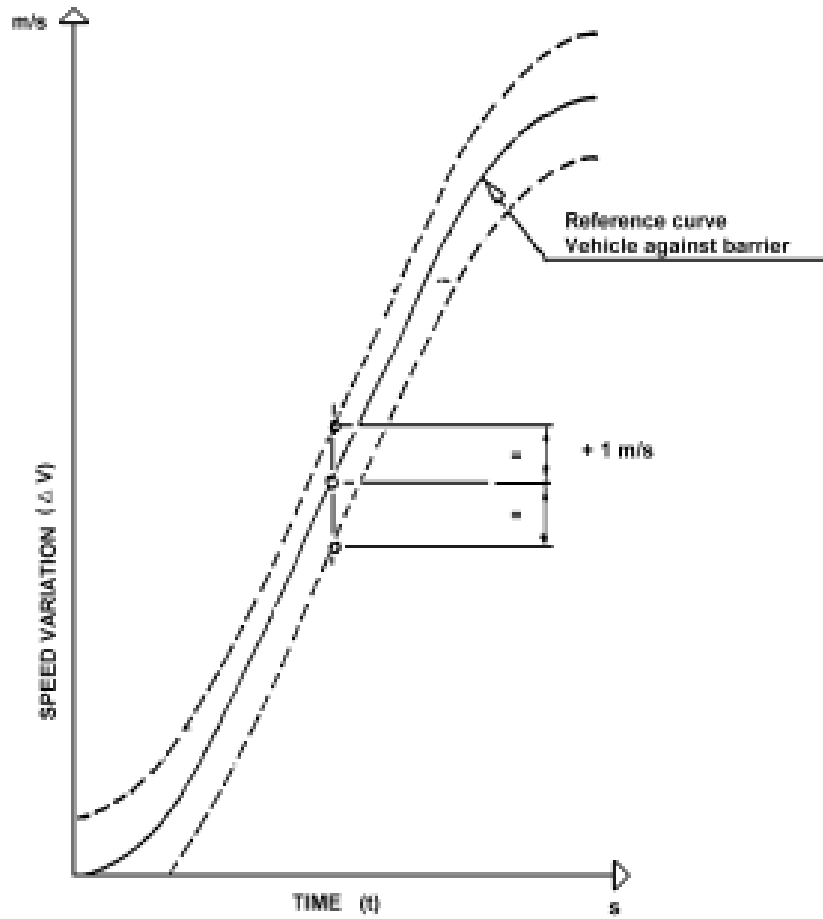

ANNEX 5

(See 5.2.1)

**TECHNIQUE OF MEASUREMENT IN MEASUREMENT TESTS:
INSTRUMENTATION****1. DEFINITIONS****1.1. Data Channel**

A data channel comprises all the instrumentation from a transducer (or multiple transducers whose outputs are combined in some specified way) up to and including any analysis procedures that may alter the frequency content or the amplitude content of data.

1.2. Transducer

The first device in a data channel used to convert a physical quantity to be measured into a second quantity (such as an electrical voltage) which can be processed by the remainder of the channel.

1.3. Channel Amplitude Class: CAC

The designation for a data channel that meets certain amplitude characteristics as specified in this Annex. The CAC number is numerically equal to the upper limit of the measurement range.

1.4. Characteristic Frequencies F_H , F_L , F_N

These frequencies are defined in Figure 1.

1.5. Channels Frequency Class: CFC

The channel frequency class is designated by a number indicating that the channel frequency response lies within the limits specified in Figure 1. This number and the value of the frequency F_H in Hz are numerically equal.

1.6. Sensitivity Coefficient

The slope of the straight line representing the best fit to the calibration values determined by the method of least square within the channel amplitude class.

1.7. Calibration Factor of a Data Channel

The mean value of the sensitivity coefficients evaluated over frequencies which are evenly spaced on a logarithmic scale between F_L and $F_H / 2.5$.

1.8. Linearity Error

The ratio, in per cent, of the maximum difference between the calibration value and the corresponding value read on the straight line defined in paragraph 1.6. at the upper limit of the channel amplitude class.

1.9. Cross Sensitivity

The ratio of the output signal to the input signal when an excitation is applied to the transducer perpendicular to the measurement axis. It is expressed as a percentage of the sensitivity along the measurement axis.

1.10. Phase Delay Time

The phase delay time of a data channel is equal to the phase delay (in radians) of a sinusoidal signal, divided by the angular frequency of that signal (in radians/second).

1.11. Environment

The aggregate, at a given moment, of all external conditions and influences to which the data channel is subjected.

2. PERFORMANCE REQUIREMENTS**2.1. Linearity Error**

The absolute value of the linearity error of a data channel at any frequency in the CFC, shall be equal to or less than 2.5% of the value of the CAC, over the whole measurement range.

2.2. Amplitude Against Frequency

The frequency response of a data channel shall lie within the limiting curves given in Figure 1. The zero dB line is determined by the calibration factor.

2.3. Phase Delay Time

The phase delay time between the input and the output signals of a data channel shall be determined and shall not vary by more than $1/10 F_H$ seconds between $0.03 F_H$ and F_H .

2.4. Time

2.4.1. Time Base

A time base shall be recorded and shall at least give 1/100 s with an accuracy of 1%.

2.4.2. Relative Time Delay

The relative time delay between the signal of two or more data channels, regardless of their frequency class, shall not exceed 1 ms excluding delay caused by phase shift.

Two or more data channels of which the signals are combined shall have the same frequency class and shall not have relative time delay greater than $1/10 F_H$ seconds.

This requirement applies to analogue signals as well as to synchronization pulses and digital signals.

2.5. Transducer Cross Sensitivity

The transducer cross sensitivity shall be less than 5% in any direction.

2.6. Calibration

2.6.1. General

A data channel shall be calibrated at least once a year against reference equipment traceable to known standards. The methods used to carry out a comparison with reference equipment shall not introduce an error greater than 1% of the CAC. The use of the reference equipment is limited to the frequency range for which they have been calibrated. Subsystems of a data channel may be evaluated individually and the results factored into the accuracy of the total data channel. This can be done for example by an electrical signal of known amplitude simulating the output signal of the transducer which allows a check to be made on the gain factor of the data channel, excluding the transducer.

2.6.2. Accuracy of Reference Equipment for Calibration

The accuracy of the reference equipment shall be certified or endorsed by an official metrology service.

2.6.2.1. Static calibration

2.6.2.1.1. Accelerations

The errors shall be less than $\pm 1.5\%$ of the channel amplitude class.

2.6.2.1.2. Forces

The error shall be less than $\pm 1\%$ of the channel amplitude class.

2.6.2.1.3. Displacements

The error shall be less than $\pm 1\%$ of the channel amplitude class.

2.6.2.2. Dynamic calibration

2.6.2.2.1. Accelerations

The error in the reference accelerations expressed as a percentage of the channel amplitude class shall be less than $\pm 1.5\%$ below 400 Hz, less than $\pm 2\%$ between 400 Hz and 900 Hz, and less than $\pm 2.5\%$ above 900 Hz.

2.6.2.3. Time

The relative error in the reference time shall be less than 10^{-5} .

2.6.3. Sensitivity Coefficient and Linearity Error

The sensitivity coefficient and the linearity error shall be determined by measuring the output signal of the data channel against a known input signal for various values of this signal. The calibration of the data channel shall cover the whole range of the amplitude class.

For bi-directional channels, both the positive and negative values shall be used. If the calibration equipment cannot produce the required input owing to the excessively high values of the quantity to be measured, calibrations shall be carried out within the limits of the calibration standards and these limits shall be recorded in the test report.

A total data channel shall be calibrated at a frequency or at a spectrum of frequencies having a significant value between F_L and $F_H / 2.5$

2.6.4. Calibration of the Frequency Response

The response curves of phase and amplitude against frequency shall be determined by measuring the output signals of the data channel in terms of phase and amplitude against a known input signal, for various values of this signal varying between F_L and 10 times the CFC or 3000 Hz, whichever is lower.

2.7. **Environmental Effects**

A regular check shall be made to identify any environmental influence (such as electric or magnetic flux, cable velocity, etc.). This can be done for instance by recording the output of spare channels equipped with dummy transducers. If significant output signals are obtained corrective action shall be taken, for instance by replacement of cables.

2.8. **Choice and Designation of the Data Channel**

The CAC and CFC define a data channel.
The CAC shall be 1, 2 or 5 to a power of ten.

3. **MOUNTING OF TRANSDUCERS**

Transducers should be rigidly secured so that their recordings are affected by vibration as little as possible. Any mounting having a lowest resonance frequency equal to at least 5 times the frequency F_H of the data channel considered shall be considered valid. Acceleration transducers in particular should be mounted in such a way that the initial angle of the real measurement axis to the corresponding axis of the reference axis system is not greater than 5° unless an analytical or experimental assessment of the effect of the mounting on the collected data is made. When multi-axial accelerations at a point are to be measured, each acceleration transducer axis should pass within 10 mm of that point, and the centre of seismic mass of each accelerometer should be within 30 mm of that point.

4. **RECORDING**

4.1. **Analogue Magnetic Recorder**

Tape speed should be stable to within not more than 0.5% of the tape speed used. The signal-to-noise ratio of the recorder should not be less than 42 dB at the maximum tape speed. The total harmonic distortion should be less than 3% and the linearity error should be less than 1% of the measurement range.

4.2. **Digital Magnetic Recorder**

Tape speed should be stable to within not more than 10% of the tape speed used.

4.3. **Paper Tape Recorder**

In case of direct data recording the paper speed in mm/s should be at least 1.5 times the number expressing F_H in Hz. In other cases the paper speed should be such that equivalent resolution is obtained.

5. DATA PROCESSING

5.1. Filtering

Filtering corresponding to the frequencies of the data channel class may be carried out during either recording or processing of data. However, before recording, analogical filtering at a higher level than CFC should be effected in order to use at least 50% of the dynamic range of the recorder and to reduce the risk of high frequencies saturating the recorder or causing aliasing errors in the digitizing process.

5.2. Digitizing

5.2.1. Sampling Frequency

The sampling frequency should be equal to at least $8 F_H$. In the case of analogical recording, when the recording and reading speeds are different, the sampling frequency can be divided by the speed ratio.

5.2.2. Amplitude Resolution

The size of digital words should be at least 7 bits and a parity bit.

6. PRESENTATION OF RESULTS

The results should be presented on A4 size paper (ISO/R 216). Results presented as diagrams should have axes scaled with a measurement unit corresponding to a suitable multiple of the chosen unit (for example, 1, 2, 5, 10, 20 millimeters). SI units shall be used, except for vehicle velocity, where km/h may be used, and for accelerations due to impact where g, with $g = 9.81 \text{ m/s}^2$, may be used.

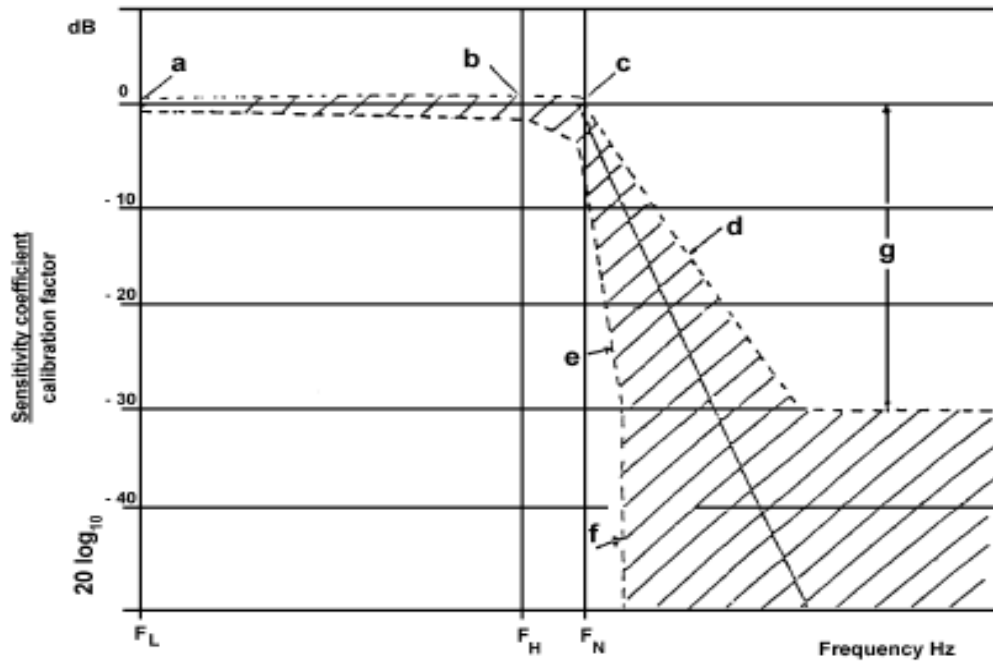

Figure 1
Frequency Response curve

CFC	F_L	F_H	F_N
	Hz	Hz	Hz
1000	≤ 0.1	1000	1650
600	≤ 0.1	600	1000
180	≤ 0.1	180	300
60	≤ 0.1	60	100

N	Logarithmic Scale	
	a	+/- 0.5
b	+/- 0.5;-1	dB
c	0.5;-4	dB
d	-9	dB/octave
e	-24	dB/octave
f	Infinity	
g	-30	

ANNEX 6
(See Annex 1- 1.2)

DEFINITION OF DEFORMABLE BARRIER

1. COMPONENT AND MATERIAL SPECIFICATIONS

The dimensions of the barrier are illustrated in Figure 1 of this Annex. The dimensions of the individual components of the barrier are listed separately below.

1.1. Main Honeycomb Block

Dimensions

Height: 650 mm (in direction of honeycomb ribbon axis)

Width: 1000 mm

Depth: 450 mm (in direction of honeycomb cell axes)

All above dimensions should allow a tolerance of ± 2.5 mm

Material: Aluminium 3003 (ISO 209, Part 1)

Foil Thickness: $0.076 \text{ mm} \pm 15\%$

Cell Size: $19.1 \text{ mm} \pm 20\%$

Density: $28.6 \text{ kg/m}^3 \pm 20\%$

Crush Strength: $0.342 \text{ MPa} +0\% -10\%$ ⁽¹⁾

(1) In accordance with the certification procedure described in paragraph 2 of this Annex.

1.2. **Bumper Element**

Dimensions

Height: 330 mm (in direction of honeycomb ribbon axis)

Width: 1000 mm

Depth: 90 mm (in direction of honeycomb cell axes)

All above dimensions should allow a tolerance of ± 2.5 mm

Material: Aluminium 3003 (ISO 209, Part 1)

Foil Thickness: $0.076 \text{ mm} \pm 15\%$

Cell Size: $6.4 \text{ mm} \pm 20\%$

Density: $82.6 \text{ kg/m}^3 \pm 20\%$

Crush Strength: $1.711 \text{ MPa} +0\% -10\%$ ⁽¹⁾

1.3. **Backing Sheet**

Dimensions

Height: $800 \text{ mm} \pm 2.5 \text{ mm}$

Width: $1000 \text{ mm} \pm 2.5 \text{ mm}$

Thickness: $2.0 \text{ mm} \pm 0.1 \text{ mm}$

1.4. **Cladding Sheet**

Dimensions

Length: $1700 \text{ mm} \pm 2.5 \text{ mm}$

Width: $1000 \text{ mm} \pm 2.5 \text{ mm}$

Thickness: $0.81 \pm 0.07 \text{ mm}$

Material: Aluminium 5251/5052 (ISO 209, Part 1)

(1) In accordance with the certification procedure described in paragraph 2 of this Annex.

1.5. **Bumper Facing Sheet**

Dimensions

Height:	330 mm ± 2.5 mm
Width:	1000 mm ± 2.5 mm
Thickness:	0.81 mm ± 0.07 mm
Material:	Aluminium 5251/5052 (ISO 209, Part 1)

Adhesive

The adhesive to be used throughout should be a two-part polyurethane (such as Ciba-Geigy XB5090/1 resin with XB5304 hardener, or equivalent).

2 ALUMINIUM HONEYCOMB CERTIFICATION

A complete testing procedure for certification of aluminum honeycomb is given in NHTSA TP-214D. The following is a summary of the procedure that should be applied to materials for the frontal impact barrier, these materials having crush strength of 0.342 MPa and 1.711 MPa respectively.

2.1 Sample Locations

To ensure uniformity of crush strength across the whole of the barrier face, eight samples shall be taken from four locations evenly spaced across the honeycomb block. For a block to pass certification, seven of these eight samples shall meet the crush strength requirements of the following sections.

The location of the samples depends on the size of the honeycomb block. First, four samples, each measuring 300 mm x 300 mm x 50 mm thick shall be cut from the block of barrier face material. Please refer to Figure 2 for an illustration of how to locate these sections within the honeycomb block. Each of these larger samples shall be cut into samples for certification testing (150 mm x 150 mm x 50 mm). Certification shall be based on the testing of two samples from each of these locations. The other two should be made available to the applicant, upon request.

2.2 Sample Size

Samples of the following size shall be used for testing:

Length: 150 mm ± 6 mm

Width: 150 mm ± 6 mm

Thickness: 50 mm ± 2 mm

The walls of incomplete cells around the edge of the sample shall be trimmed as follows:

In the "W" direction, the fringes shall be no greater than 1.8 mm (see Figure 3).

In the "L" direction, half the length of one bonded cell wall (in the ribbon direction) shall be left at either end of the specimen (see Figure 3).

2.3. Area Measurement

The length of the sample shall be measured in three locations, 12.7 mm from each end and in the middle, and recorded as L_1 , L_2 and L_3 (Figure 3). In the same manner, the width shall be measured and recorded as W_1 , W_2 and W_3 (Figure 3). These measurements shall be taken on the centreline of the thickness. The crush area shall then be calculated as:

$$A = \frac{(L_1 + L_2 + L_3)}{3} \times \frac{(W_1 + W_2 + W_3)}{3}$$

2.4. Crush Rate and Distance

The sample shall be crushed at a rate of not less than 5.1 mm/min and not more than 7.6 mm/min. The minimum crush distance shall be 16.5 mm.

2.5 Data Collection

Force versus deflections data are to be collected in either analogue or digital form for each sample tested. If analogue data are collected then a means of converting this to digital shall be available. All digital data shall be collected at a rate of not less than 5 Hz (5 points per second).

2.6 Crush Strength Determination

Ignore all data prior to 6.4 mm of crush and after 16.5 mm of crush. Divide the remaining data into three sections or displacement intervals ($n = 1, 2, 3$) (see Figure 4) as follows:

- (1) 06.4 mm - 09.7 mm inclusive,
- (2) 09.7 mm - 13.2 mm exclusive,
- (3) 13.2 mm - 16.5 mm inclusive.

Find the average for each section as follows:

$$F(n) = \frac{F(n)_1 + F(n)_2 + \dots + F(n)_m}{m} ; m = 1, 2, 3$$

where m represents the number of data points measured in each of the three intervals. Calculate the crush strength of each section as follows:

$$S(n) = \frac{F(n)}{A}; n = 1, 2, 3$$

2.7 Sample Crush Strength Specification

For a honeycomb sample to pass this certification, the following conditions shall be met:

$$0.308 \text{ MPa} \leq S(n) \leq 0.342 \text{ MPa for } 0.342 \text{ MPa material}$$

$$1.540 \text{ MPa} \leq S(n) \leq 1.711 \text{ MPa for } 1.711 \text{ MPa material}$$

$$n = 1, 2, 3.$$

2.8 Block Crush Strength Specification

Eight samples are to be tested from four locations, evenly spaced across the block. For a block to pass certification, seven of the eight samples shall meet the crush strength specification of the previous section.

3 ADHESIVE BONDING PROCEDURE

- 3.1 Immediately before bonding, aluminum sheet surfaces to be bonded shall be thoroughly cleaned using a suitable solvent, such as 1-1-1 Trichloroethane. This is to be carried out at least twice or as required to eliminate grease or dirt deposits. The cleaned surfaces shall then be abraded using 120 grit abrasive papers. Metallic/Silicon Carbide abrasive paper is not to be used. The surfaces shall be thoroughly abraded and the abrasive paper changed regularly during the process to avoid clogging, which may lead to a polishing effect.

Following abrading, the surfaces shall be thoroughly cleaned again, as above. In total, the surfaces shall be solvent cleaned at least four times. All dust and deposits left as a result of the abrading process shall be removed, as these will adversely affect bonding.

- 3.2 The adhesive should be applied to one surface only, using a ribbed rubber roller. In cases where the honeycomb is to be bonded to aluminum sheet, the adhesive should be applied to the aluminum sheet only. A maximum of 0.5 kg/m^2 shall be applied evenly over the surface, giving a maximum film thickness of 0.5 mm.

4 CONSTRUCTION

- 4.1 The main honeycomb block shall be bonded to the backing sheet with adhesive such that the cell axes are perpendicular to the sheet. The cladding shall be bonded to the front surface of the honeycomb block. The top and bottom surfaces of the cladding sheet shall not be bonded to the main honeycomb block but should be positioned closely to it. The cladding sheet shall be adhesively bonded to the backing sheet at the mounting flanges.
- 4.2 The bumper element shall be adhesively bonded to the front of the cladding sheet such that the cell axes are perpendicular to the sheet. The bottom of the bumper element shall be flush with the bottom surface of the cladding sheet. The bumper facing sheet shall be adhesively bonded to the front of the bumper element.
- 4.3 The bumper element shall then be divided into three equal sections by means of two horizontal slots. These slots shall be cut through the entire depth of the bumper section and extend the whole width of the bumper. The slots shall be cut using a saw; their width shall be the width of the blade used and shall not exceed 4.0 mm.
- 4.4 Clearance holes for mounting the barrier are to be drilled in the mounting flanges (shown in Figure 5). The holes shall be of 9.5 mm diameter. Five holes shall be drilled in the top flange at a distance of 40 mm from the top edge of the flange and five in the bottom flange, 40 mm from the bottom edge of that flange. The holes shall be at 100 mm, 300 mm, 500 mm, 700 mm, 900 mm from either edge of the barrier. All holes shall be drilled to ± 1 mm of the nominal distances. These hole locations are a recommendation only. Alternative positions may be used which offer at least the mounting strength and security provided by the above mounting specifications.

5 MOUNTING

- 5.1 The deformable barrier shall be rigidly fixed to the edge of a mass of not less than 7×10^4 kg or to some structure attached thereto. The attachment of the barrier face shall be such that the vehicle shall not contact any part of the structure more than 75 mm from the top surface of the barrier (excluding the upper flange) during any stage of the impact ⁽¹⁾. The front face of the surface to which the deformable barrier is attached shall be flat and continuous over the height and width of the face and shall be vertical $\pm 1^\circ$ and perpendicular $\pm 1^\circ$ to the axis of the run-up track.

The attachment surface shall not be displaced by more than 10 mm during the test. If necessary, additional anchorage or arresting devices shall be used to prevent displacement of the concrete block. The edge of the deformable barrier shall be aligned with the edge of the concrete block appropriate for the side of the vehicle to be tested.

- 5.2 The deformable barrier shall be fixed to the concrete block by means of ten bolts, five in the top mounting flange and five in the bottom. These bolts shall be of at least 8 mm diameter. Steel clamping strips shall be used for both the top and bottom mounting flanges (see Figures 1 and 5). These strips shall be 60 mm high and 1000 mm wide and have a thickness of at least 3 mm. The edges of the clamping strips should be rounded-off to prevent tearing of the barrier against the strip during impact. The edge of the strip should be located no more than 5 mm above the base of the upper barrier-mounting flange, or 5 mm below the top of the lower barrier-mounting flange. Five clearance holes of 9.5 mm diameter shall be drilled in both strips to correspond with those in the mounting flange on the barrier (see paragraph 4). The mounting strip and barrier flange holes may be widened from 9.5 mm up to a maximum of 25 mm in order to accommodate differences in back-plate arrangements and/or load cell wall hole configurations. None of the fixtures shall fail in the impact test. In the case where the deformable barrier is mounted on a load cell wall (LCW) it should be noted that the above dimensional requirements for mountings are intended as a minimum. Where a LCW is present, the mounting strips may be extended to accommodate higher mounting holes for the bolts. If the strips are required to be extended, then thicker gauge steel should be used accordingly, such that the barrier does not pull away from the wall, bend or tear during the impact. If an alternative method of mounting the barrier is used, it should be at least as secure as that specified in the above paragraphs.

(1) A mass, the end of which is between 125mm and 925mm high and 1000mm deep, is considered to satisfy this requirement.

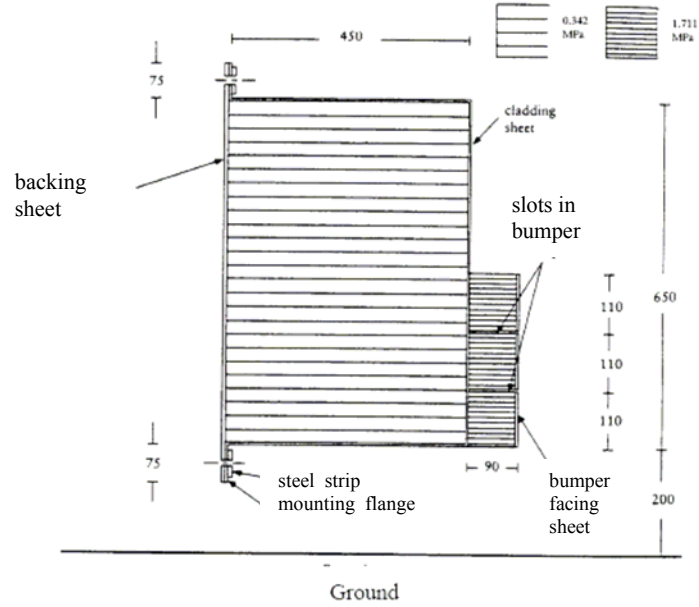

Barrier width: 1 000 mm
All dimensions in mm.

Figure 1

Deformable Barrier for Frontal Impact Testing

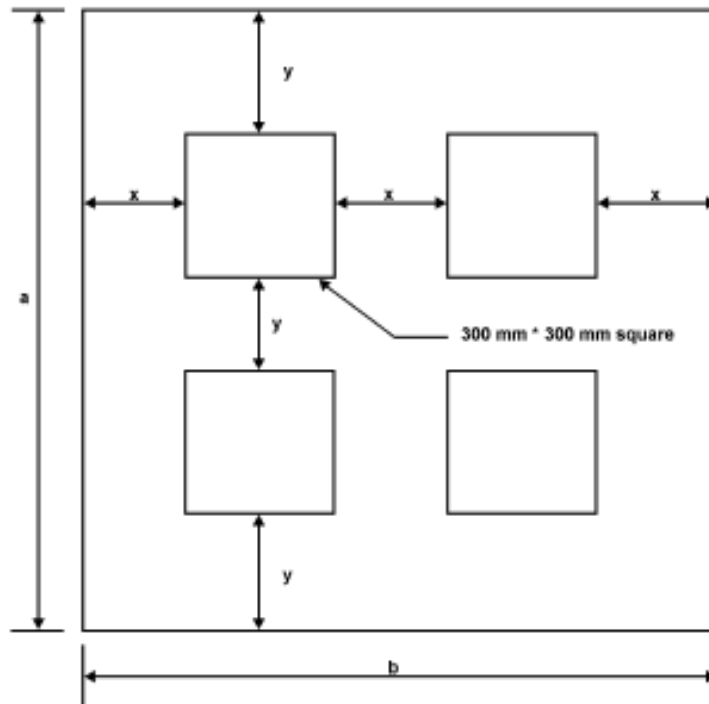

If $a \geq 900$ mm: $x = 1/3 (b-600$ mm) and $y = 1/3 (a-600$ mm) (for $a \leq b$)

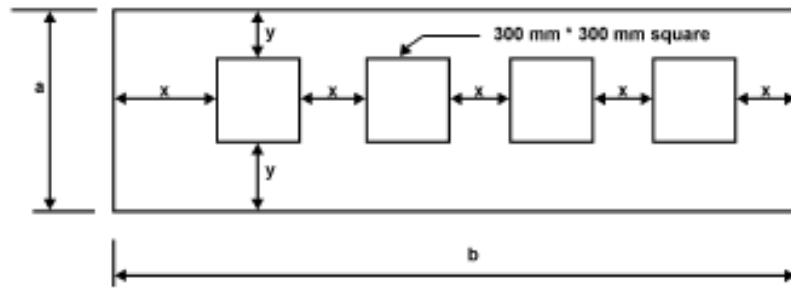

If $a \leq 900$ mm: $x = 1/5 (b-1200$ mm) and $y = 1/2 (a-300$ mm) (for $a \leq b$)

Figure 2

Locations of Samples for Certification

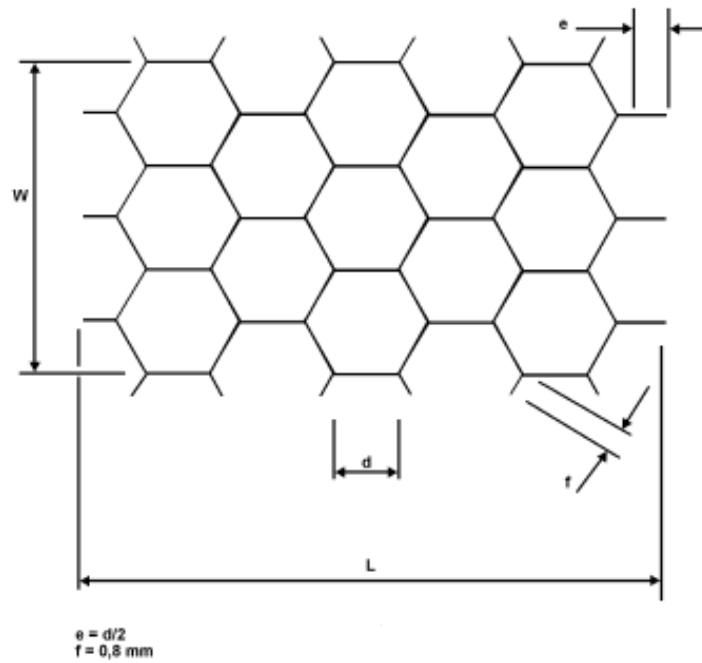

Figure 3

Honeycomb Axes and Measured Dimensions

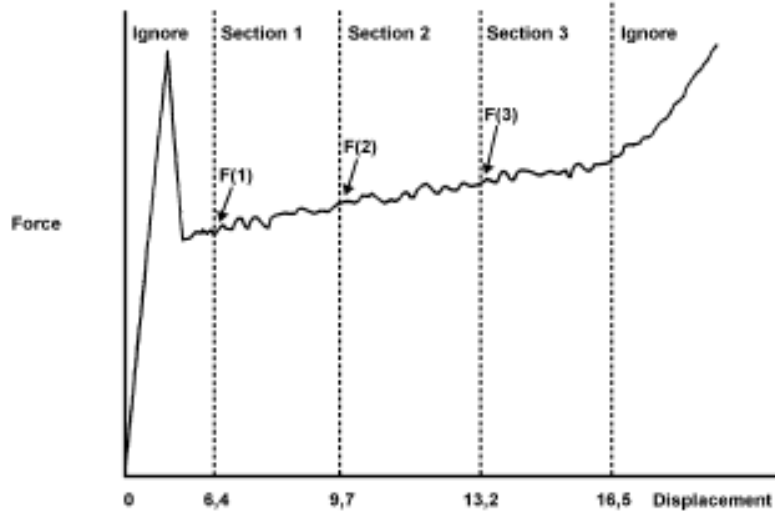
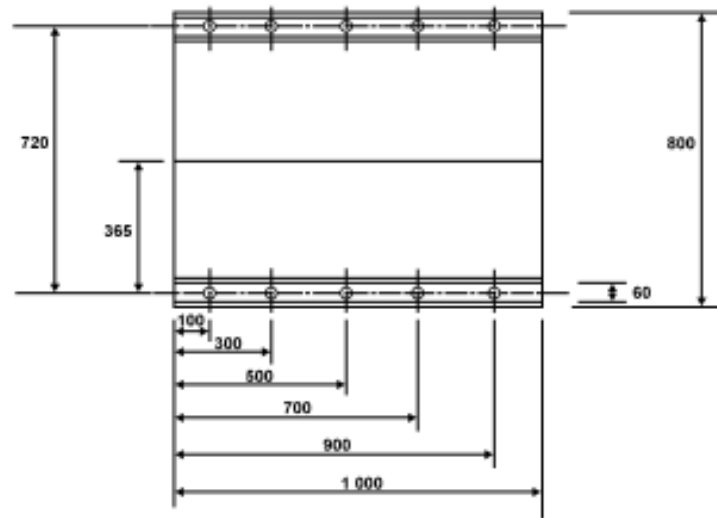

Figure 4
Crush Force and Displacement



Hole diameters 9,5 mm.
 All dimensions in mm.

Figure 5
Positions of Holes for Barrier Mounting

ANNEX 7

(See Annex 1- 2.1.1)

**CERTIFICATION PROCEDURE FOR
THE DUMMY LOWER LEG AND FOOT****1. UPPER FOOT IMPACT TEST**

- 1.1. The objective of this test is to measure the response of Hybrid III foot and ankle to well-defined, hard-faced pendulum impacts.
- 1.2. The complete Hybrid III lower leg assembly, left (86-5001-001) and right (86-5001-002), equipped with the foot and ankle assembly, left (78051-614) and right (78051-615), shall be used, including the knee assembly.

The load cell simulator (78051-319 Rev A) shall be used to secure the knee assembly (78051-16 Rev B) to the test fixture.

1.3. Test Procedure

- 1.3.1. Each leg assembly shall be maintained (soaked) for 4 hours prior to the test at a temperature of $22 \pm 3^{\circ}\text{C}$ and a relative humidity of $40 \pm 30\%$. The soak period shall not include the time required to reach steady state conditions.
- 1.3.2. Clean the impact surface of the skin and also the impactor face with isopropyl alcohol or equivalent prior to the test. Dust with talc.
- 1.3.3. Align the impactor accelerometer with its sensitive axis parallel to the direction of impact at contact with the foot.
- 1.3.4. Mount the leg assembly to the fixture shown in Figure 1. The test fixture shall be rigidly secured to prevent movement during impact. The centre line of the femur load cell simulator (78051-319) shall be vertical with a tolerance of ± 0.5 . Adjust the mount such that the line joining the knee clevis joint and the ankle attachment bolt is horizontal with a tolerance of $\pm 3^{\circ}$, with the heel resting on two sheets of a flat low friction (PTFE sheet) surface. Ensure that the tibia flesh is located fully towards the knee end of the tibia. Adjust the ankle such that the plane of the underside of the foot is vertical and perpendicular to the direction of impact with a tolerance of $\pm 3^{\circ}$ and such that the midsagittal plane of the foot is aligned with the pendulum arm. Adjust the knee joint to 1.5 ± 0.5 g range before each test. Adjust the ankle joint so that it is free and then tighten just sufficiently to keep the foot stable on the PTFE sheet.

- 1.3.5. The rigid impactor comprises a horizontal cylinder diameter 50 ± 2 mm and a pendulum support arm diameter 19 ± 1 mm (Figure 4). The cylinder has a mass of 1.25 ± 0.02 kg including instrumentation and any part of the support arm within the cylinder. The pendulum arm has a mass of 285 ± 5 g. The mass of any rotating part of the axle to which the support arm is attached should not be greater than 100 g. The length between the central horizontal axis of the impactor cylinder and the axis of rotation of the whole pendulum shall be $1\,250 \pm 1$ mm. The impact cylinder is mounted with its longitudinal axis horizontal and perpendicular to the direction of impact. The pendulum shall impact the underside of the foot, at a distance of 185 ± 2 mm from the base of the heel resting on the rigid horizontal platform, so that the longitudinal centre line of the pendulum arm falls within 1° of a vertical line at impact. The impactor shall be guided to exclude significant lateral, vertical or rotational movement.
- 1.3.6. Allow a period of at least 30 minutes between successive tests on the same leg.
- 1.3.7. The data acquisition system, including transducers, shall conform to the specifications for CFC 600, as described in Annex 5.

1.4. **Performance Specification**

- 1.4.1. When each ball of the foot is impacted at $6.7 (\pm 0.1)$ m/s in accordance with paragraph 1.3, the maximum lower tibia bending momentum about the y-axis (M_y) shall be 120 ± 25 Nm.

2. **LOWER FOOT IMPACT TEST WITHOUT SHOE**

- 2.1. The objective of this test is to measure the response of the Hybrid III foot skin and insert to well-defined, hard-faced pendulum impacts.
- 2.2. The complete Hybrid III lower leg assembly, left (86-5001-001) and right (86-5001-002), equipped with the foot and ankle assembly, left (78051-614) and right (78051-615), shall be used, including the knee assembly.

The load cell simulator (78051-319 Rev A) shall be used to secure the knee assembly (78051-16 Rev B) to the test fixture.

2.3. **Test Procedure**

- 2.3.1. Each leg assembly shall be maintained (soaked) for 4 hours prior to the test at a temperature of $22 \pm 3^\circ\text{C}$ and a relative humidity of $40 \pm 30\%$. The soak period shall not include the time required to reach steady state conditions.
- 2.3.2. Clean the impact surface of the skin and also the impactor face with isopropyl alcohol or equivalent prior to the test. Dust with talc. Check that there is no visible damage to the energy-absorbing insert to the heel.

- 2.3.3. Align the impactor accelerometer with its sensitive axis parallel to the impactor longitudinal centre line.
- 2.3.4. Mount the leg assembly to the fixture shown in Figure 2. The test fixture shall be rigidly secured to prevent movement during impact. The centre line of the femur load cell simulator (78051-319) shall be vertical with a tolerance of $\pm 0.5^\circ$. Adjust the mount such that the line joining the knee clevis joint and the ankle attachment bolt is horizontal with a tolerance of $\pm 3^\circ$ with the heel resting on two sheets of a flat low-friction (PTFE sheet) surface. Ensure that the tibia flesh is located fully towards the knee end of the tibia. Adjust the ankle such that the plane of the underside of the foot is vertical and perpendicular to the direction of the impact with a tolerance of $\pm 3^\circ$ and such that the mid sagittal plane of the foot is aligned with the pendulum arm. Adjust the knee joint to 1.5 ± 0.5 g range before each test. Adjust the ankle joint so that it is free and then tighten just sufficiently to keep the foot stable on the PTFE sheet.
- 2.3.5. The rigid impactor comprises a horizontal cylinder diameter 50 ± 2 mm and a pendulum support arm diameter 19 ± 1 mm (Figure 4). The cylinder has a mass of 1.25 ± 0.02 kg including instrumentation and any part of the support arm within the cylinder. The pendulum arm has a mass of 285 ± 5 g. The mass of any rotating part of the axle to which the support arm is attached should not be greater than 100 g. The length between the central horizontal axis of the impactor cylinder and the axis of rotation of the whole pendulum shall be 1250 ± 1 mm. The impact cylinder is mounted with its longitudinal axis horizontal and perpendicular to the direction of impact. The pendulum shall impact the underside of the foot, at a distance of 62 ± 2 mm from the base of the heel resting on the rigid horizontal platform, so that the longitudinal centre line of the pendulum arm falls within 1° of a vertical line at impact. The impactor shall be guided to exclude significant lateral, vertical or rotational movement.
- 2.3.6. Allow a period of at least 30 minutes between successive tests on the same leg.
- 2.3.7. The data acquisition system, including transducers, shall conform to the specifications for CFC 600, as described in Annex 5.

2.4. Performance Specification

- 2.4.1. When each heel of the foot is impacted at 4.4 ± 0.1 m/s in accordance with paragraph 2.3., the maximum impactor acceleration shall be 295 ± 50 g.

3. LOWER FOOT IMPACT TEST (WITH SHOE)

- 3.1. The objective of this test is to control the response of the shoe and Hybrid III heel flesh and ankle joint to well-defined hard-faced pendulum impacts.

- 3.2. The complete Hybrid III lower leg assembly, left (86-5001-001) and right (86-5001-002), equipped with the foot and ankle assembly, left (78051-614) and right (78051-615), shall be used, including the knee assembly. The load cell simulator (78051-319 Rev A) shall be used to secure the knee assembly (78051-16 Rev B) to the test fixture. The foot shall be fitted with the shoe specified in Annex 3, paragraph 2.9.2.
- 3.3. **Test Procedure**
- 3.3.1. Each leg assembly shall be maintained (soaked) for 4 hours prior to the test at a temperature of $22 \pm 3^{\circ}\text{C}$ and a relative humidity of $40 \pm 30\%$. The soak period shall not include the time required to reach steady state conditions.
- 3.3.2. Clean the impact surface of the underside of the shoe with a clean cloth and the impactor face with isopropyl alcohol or equivalent prior to the test. Check that there is no visible damage to the energy-absorbing insert to the heel.
- 3.3.3. Align the impactor accelerometer with its sensitive axis parallel to the impactor longitudinal centre line.
- 3.3.4. Mount the leg assembly to the fixture shown in Figure 3. The test fixture shall be rigidly secured to prevent movement during impact. The centre line of the femur load cell simulator (78051-319) shall be vertical with a tolerance of $\pm 0.5^{\circ}$. Adjust the mount such that the line joining the knee clevis joint and the ankle attachment bolt is horizontal with a tolerance of $\pm 3^{\circ}$ with the heel of the shoe resting on two sheets of a flat low-friction (PTFE sheet) surface. Ensure that the tibia flesh is located fully towards the knee end of the tibia. Adjust the ankle such that a plane in contact with the heel and sole of the underside of the shoe is vertical and perpendicular to the direction of impact with a tolerance of $\pm 3^{\circ}$ and such that the midsagittal plane of the foot, and shoe is aligned with the pendulum arm. Adjust the knee joint to 1.5 ± 0.5 g range before each test. Adjust the ankle joint so that it is free and then tighten just sufficiently to keep the foot stable on the PTFE sheet.
- 3.3.5. The rigid impactor comprises a horizontal cylinder diameter 50 ± 2 mm and a pendulum support arm diameter 19 ± 1 mm (Figure 4). The cylinder has a mass of 1.25 ± 0.02 kg including instrumentation and any part of the support arm within the cylinder. The pendulum arm has a mass of 285 ± 5 g. The mass of any rotating part of the axle to which the support arm is attached should not be greater than 100 g. The length between the central horizontal axis of the impactor cylinder and the axis of rotation of the whole pendulum shall be $1\,250 \pm 1$ mm. The impact cylinder is mounted with its longitudinal axis horizontal and perpendicular to the direction of impact. The pendulum shall impact the heel of the shoe in a horizontal plane which is a distance of 62 ± 2 mm

above the base of the dummy heel when the shoe is resting on the rigid horizontal platform, so that the longitudinal centre line of the pendulum arm falls within 1° of a vertical line at impact. The impactor shall be guided to exclude significant lateral, vertical or rotational movement.

3.3.6. Allow a period of at least 30 minutes between successive tests on the same leg.

3.3.7. The data acquisition system, including transducers, shall conform to the specifications for CFC 600, as described in Annex 5.

3.4. **Performance Specifications**

3.4.1. When the heel of the shoe is impacted at 6.7 ± 0.1 m/s in accordance with paragraph 3.3., the maximum tibia compressive force (F_z) shall be 3.3 ± 0.5 kN.

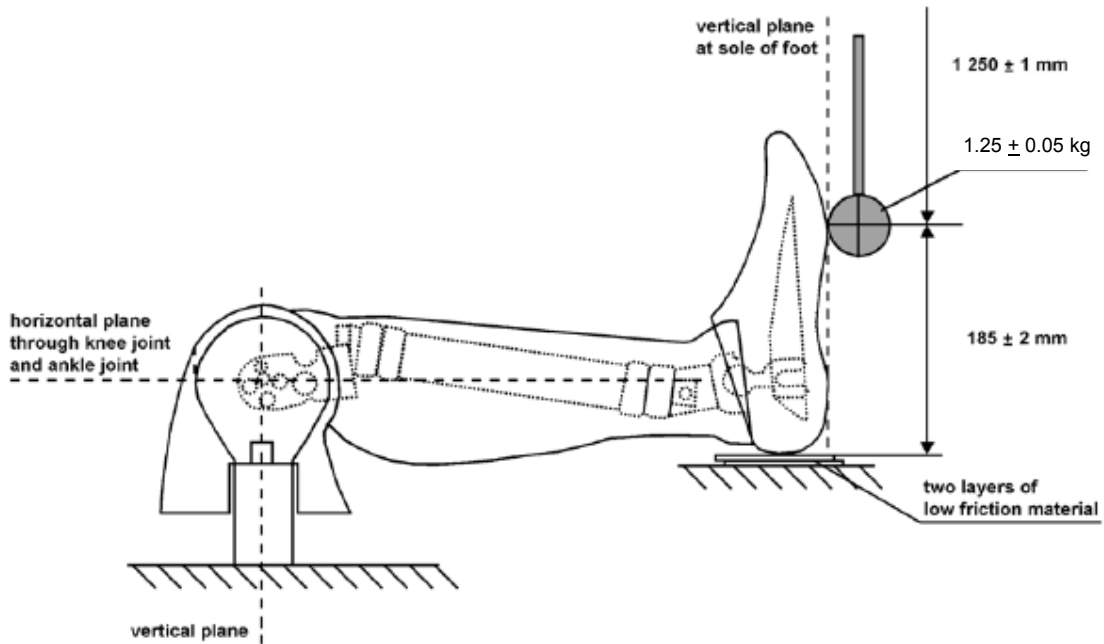

Figure 1

Upper Foot Impact Test - Test Set-up Specifications

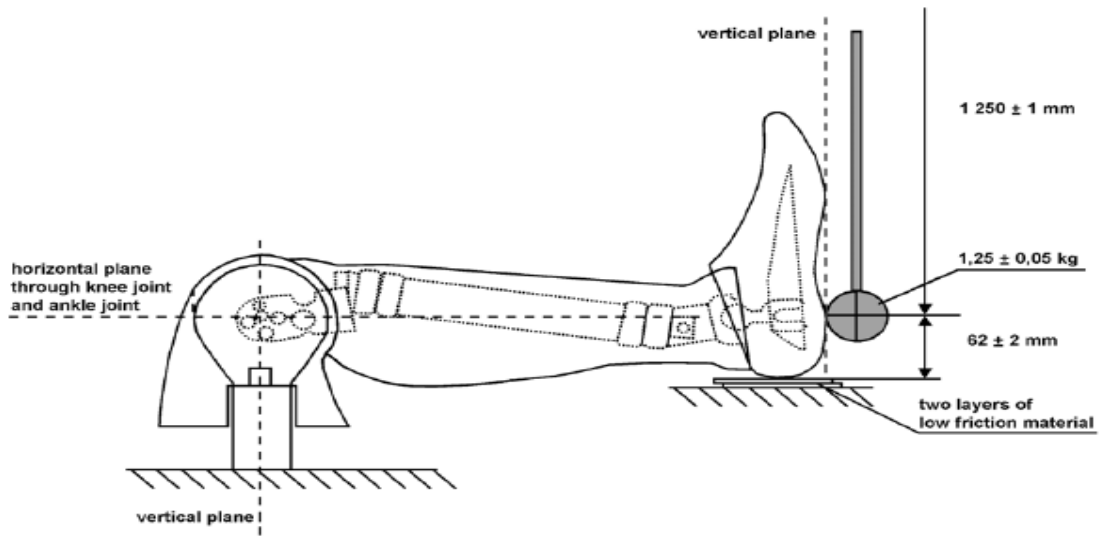

Figure 2
Lower Foot Impact Test (Without Shoe) - Test Set-up Specifications

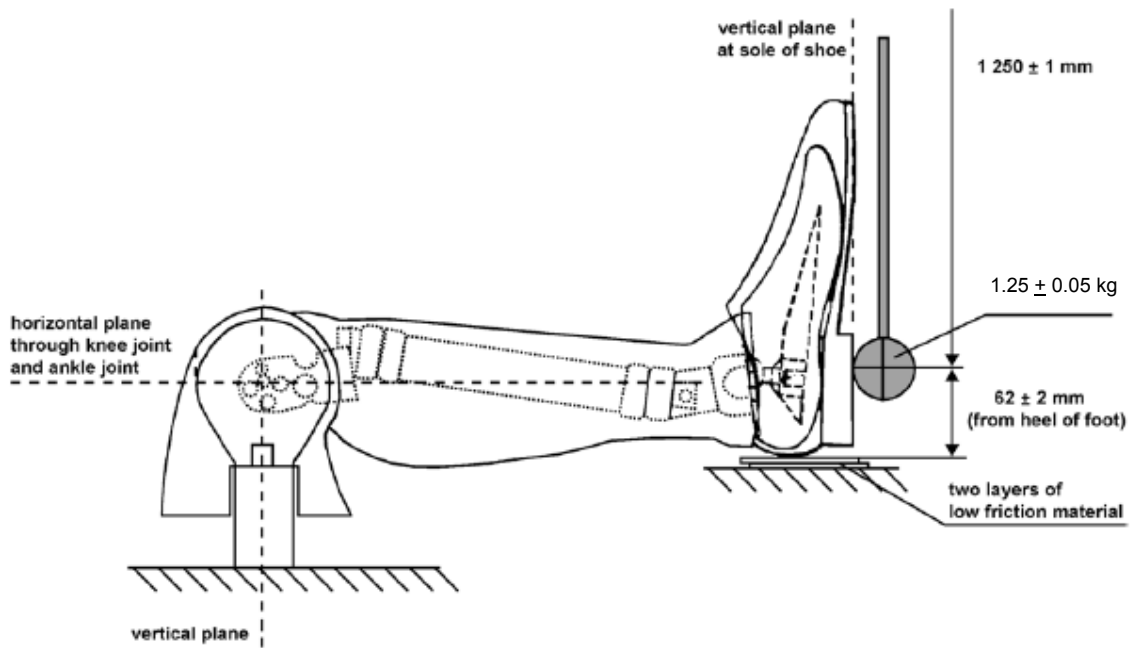

Figure 3
Lower Foot Impact Test (With Shoe) - Test Set-up Specifications

Material : aluminium alloy
Mass of arm : $285 \pm 5\text{g}$
Mass of impact cylinder :
 $1250 \pm 20\text{g}$

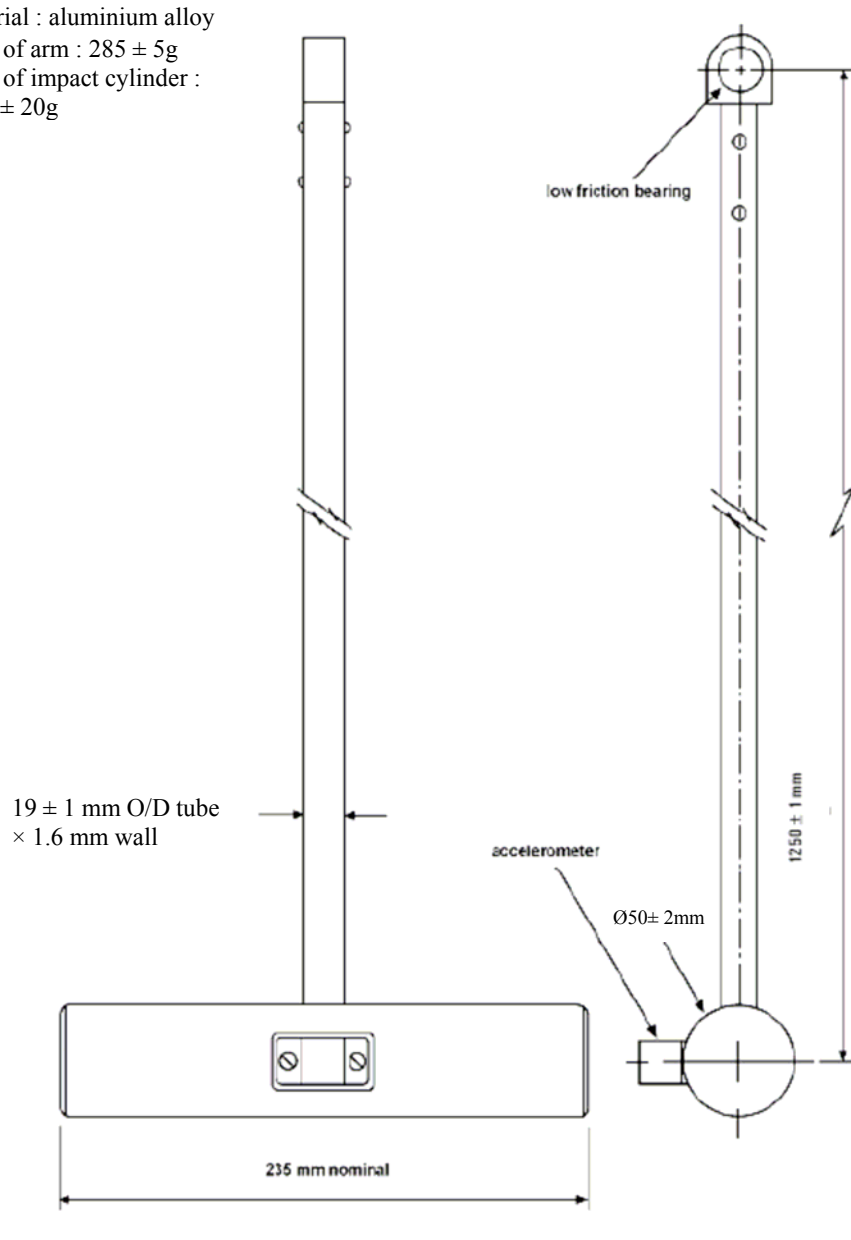

Figure 4
Pendulum Impactor

ANNEX 8

(See Introduction)

COMMITTEE COMPOSITION *
Automotive Industry Standards Committee

Chairman	
Shri Shrikant R. Marathe	Director The Automotive Research Association of India, Pune
Members	Representing
Representative from	Ministry of Shipping, Road Transport & Highways (Dept. of Road Transport & Highways), New Delhi
Representative from	Ministry of Heavy Industries & Public Enterprises (Department of Heavy Industry), New Delhi
Shri Chandan Saha	Office of the Development Commissioner, Small Scale Industries, Ministry of Small Scale Industries, New Delhi
Shri Rakesh Kumar	Bureau of Indian Standards, New Delhi
Director Shri D. P. Saste (Alternate)	Central Institute of Road Transport, Pune
Dr. M. O. Garg	Indian Institute of Petroleum, Dehra Dun
Dr. C. L. Dhamejani	Vehicles Research & Development Establishment, Ahmednagar
Representatives from	Society of Indian Automobile Manufacturers
Shri T.C. Gopalan Shri Ramakant Garg (Alternate)	Tractor Manufacturers Association, New Delhi
Shri K.N.D. Nambudiripad	Automotive Components Manufacturers Association of India, New Delhi
Shri Arvind Gupta	Automotive Components Manufacturers Association of India, New Delhi

Member Secretary
Mrs. Rashmi Urdhwarshie
Deputy Director
The Automotive Research Association of India, Pune

* At the time of approval of this Automotive Industry Standard (AIS)