

**AUTOMOTIVE INDUSTRY STANDARD**

**Test Method, Testing Equipment and Related  
Procedures for Type Approval and  
Conformity of Production (COP)  
Testing of L2 category Vehicles for  
Bharat Stage VI emission norms as per  
CMV Rules 115, 116 and 126**

PRINTED BY  
THE AUTOMOTIVE RESEARCH ASSOCIATION OF INDIA  
P.B. NO. 832, PUNE 411 004

ON BEHALF OF  
AUTOMOTIVE INDUSTRY STANDARDS COMMITTEE

UNDER  
CENTRAL MOTOR VEHICLE RULES – TECHNICAL STANDING COMMITTEE

SET-UP BY  
MINISTRY OF ROAD TRANSPORT & HIGHWAYS  
(DEPARTMENT OF ROAD TRANSPORT & HIGHWAYS)  
GOVERNMENT OF INDIA

February 2019

**Status chart of the Standard to be used by the purchaser for updating the record**

Sr. No.	Corrigenda	Amendment	Revision	Date	Remark	Misc.
<b>General Remarks:</b>						

**INTRODUCTION**

In India, the mass emission norms based on Indian Driving Cycle (IDC) were notified under CMVR in 1989. The first mass emission norms for vehicles were enforced from 1<sup>st</sup> April 1991 for Gasoline vehicles and from 1<sup>st</sup> April 1992 for Diesel vehicles. Since then, progressively emission norms have been tightened.

Government of India has notified migration to Bharat Stage VI (BS VI) emissions norms for 2, 3 and 4 wheeled vehicles from 1<sup>st</sup> April 2020. For Agricultural Tractors, Construction Equipment Vehicles and Combine Harvesters (vehicles having power exceeding 37 kW) next stage emission norms Bharat Stage (CEV/TREM) – IV) are notified from 1<sup>st</sup> October 2020 and Bharat Stage (CEV/TREM) – V) from 1st April 2024. Test procedure for Type Approval and CoP for above emission norms shall be as per various parts of AIS-137, as applicable.

This Part 1 of AIS-137 prescribes Test Method, Testing Equipment and related procedures for Type Approval and Conformity of Production (COP) Testing of Vehicles of Category L2 having engine Capacity exceeding 50cc and maximum speed exceeding 50km/hr for BS VI emission norms as per CMV Rules 115, 116 and 126.

While preparing this standard, considerable assistance has been taken from following regulations/documents:

While preparing this part, considerable assistance has been taken from Following, WMTC Stage 2 cycle is considered for this Part:

<ul style="list-style-type: none"> <li>• Commission delegated regulation (EU) No 134/2014 of 16 December 2013 supplementing Regulation (EU) No 168/2013 of the European Parliament and of the Council with regard to environmental and propulsion unit</li> </ul>
<ul style="list-style-type: none"> <li>• Regulation (EU) No 168/2013 of the European parliament and of the council of 15 January 2013 on the approval and market surveillance of two- or three-wheel vehicles and quadricycles.</li> </ul>
<ul style="list-style-type: none"> <li>• Commission delegated regulation (EU) 2016/1824 of 14 July 2016 amending Delegated Regulation (EU) No 3/2014, Delegated Regulation (EU) No 44/2014 and Delegated Regulation (EU) No 134/2014 with regard, respectively, to vehicle functional safety requirements, to vehicle construction and general requirements and to environmental and propulsion unit performance requirements</li> </ul>
<ul style="list-style-type: none"> <li>• Commission delegated regulation (EU) No 44/2014 of 21 November 2013 supplementing Regulation (EU) No 168/2013 of the European Parliament and of the Council with regard to the vehicle construction and general requirements for the approval of two- or three- wheel vehicles and quadricycles.</li> </ul>

<ul style="list-style-type: none"> <li>• Commission implementing regulation (EU) No 901/2014 of 18 July 2014 implementing Regulation (EU) No 168/2013 of the European Parliament and of the Council with regard to the administrative requirements for the approval and market surveillance of two- or three-wheel vehicles and quadricycles.</li> </ul>
<ul style="list-style-type: none"> <li>• Commission delegated regulation (EU) 2018/295 of 15 December 2017 amending Delegated Regulation (EU) No 44/2014, as regards vehicle construction and general requirements, and Delegated Regulation (EU) No 134/2014, as regards environmental and propulsion unit performance requirements for the approval of two- or three-wheel vehicles and quadricycles.</li> </ul>
<ul style="list-style-type: none"> <li>• AIS 007 - Information on Technical Specifications to be submitted by the Vehicle Manufacturer</li> </ul>
<ul style="list-style-type: none"> <li>• UN GTR No. 17 - Crankcase and evaporative emissions of L-category vehicles (ECE/TRANS/180/Add.17)</li> </ul>
<ul style="list-style-type: none"> <li>• UN GTR No. 18 - On-Board Diagnostic (OBD) systems for L-category vehicles (ECE/TRANS/180/Add.18)</li> </ul>
<ul style="list-style-type: none"> <li>• Part XVII : Details of Standards for Tailpipe Emissions from spark ignition engines (Petrol, CNG and LPG) and compression ignition engines (Diesel) vehicles and Test Procedures for Mass Emission Standards (Bharat Stage IV) for Two Wheeled Vehicles</li> </ul>
<ul style="list-style-type: none"> <li>• Government of India, Gazette Notification G.S.R. 889 (E) dated 16<sup>th</sup> September, 2016 regarding implementation of Bharat Stage VI (BS VI) emission norms for 2, 3 and 4 wheeled vehicles.</li> </ul>

The Committee Composition for formulation of this standard is given in Annexure II.

After approval of the standard by SCOE, The Automotive Research Association of India, (ARAI), Pune, being the Secretariat of the AIS Committee, has published this standard. For better dissemination of this information ARAI may publish this standard on their web site.

\*\*\*\*\*

## TABLE OF CONTENTS

<b>CHAPTER &amp; APPENDIX NO.</b>	<b>DESCRIPTION</b>	<b>PAGE NO</b>
CHAPTER 1	Overall requirements	1/337
CHAPTER 2	Type I tests - Tailpipe emissions after cold start	19/337
APPENDIX 1	Symbols and Acronyms	69/337
APPENDIX 2	Technical Specification of reference fuels	77/337
APPENDIX 3	Chassis dynamometer system	78/337
APPENDIX 4	Exhaust dilution system	84/337
APPENDIX 5	Classification equivalent inertia mass and running resistance	96/337
APPENDIX 6	Driving cycles for Type I tests	99/337
APPENDIX 7	Road tests on vehicles equipped with one wheel on driven axle or twinned wheels for the determination of test bench settings.	127/337
APPENDIX 8	Explanatory note on gear shift procedure for type I tests.	133/337
APPENDIX 9	Type I test procedure for vehicles fueled with LPG, NG/Bio Methane, Flex Fuel H <sub>2</sub> NG vehicles	139/337
APPENDIX 10	Type I Test procedure for vehicles equipped with periodically regenerative system.	143/337
APPENDIX 11	COP procedure – Technical Requirements.	152/337
APPENDIX 12	Type I test procedure for hybrid category vehicles	159/337
CHAPTER 3	Type II tests - Tailpipe emission at idle (For PI engines) and at free acceleration (For CI engines).	171/337
CHAPTER 4	Type III tests - Emissions of Crankcase gases and Type IV tests – Evaporative Emissions.	177/337
APPENDIX 1	Sealed Housing for Evaporation Determination (SHED) test procedure	179/337
APPENDIX 1.1	Preconditioning requirements for a hybrid application before start of the SHED test	189/337
APPENDIX 2	Ageing test procedures for evaporative emission control devices	191/337

APPENDIX 2.1	Alternate ageing test procedures for evaporative emission control devices	193/337
APPENDIX 3	Calibration of equipment for evaporative emission testing	196/337
APPENDIX 4	COP procedure - Technical Requirements.	200/337
CHAPTER 5	Type V tests – Durability of pollution control devices.	202/337
APPENDIX 1	The Standard Road Cycle for L-Category Vehicles (SRC-LeCV)	217/337
APPENDIX 2	The USA EPA Approved Mileage Accumulation durability cycle (AMA)	226/337
APPENDIX 3	Bench ageing durability test	229/337
APPENDIX 4	Standard bench cycle (SBC)	233/337
CHAPTER 6	Test type VIII requirements: OBD stage I and stage II environmental tests	235/337
APPENDIX 1	OBD Stage I	239/337
APPENDIX 1.1	Functional aspects of On-Board Diagnostic (OBD) stage I systems	242/337
APPENDIX 1.2	Minimum monitoring requirements for an On-Board Diagnostic (OBD) system Stage I	248/337
APPENDIX 1.3	Test type VIII, On-board diagnostic environmental verification test	252/337
APPENDIX 1.4	Administrative provisions	256/337
APPENDIX 2	OBD Stage II	259/337
APPENDIX 2.1	Functional aspects of On-Board Diagnostic (OBD) systems	266/337
APPENDIX 2.2	Minimum monitoring requirements for an On-Board Diagnostics (OBD) system Stage II	277/337
APPENDIX 2.3	Test type VIII, On-board diagnostic environmental verification test	281/337
APPENDIX 2.4	Administrative provisions	287/337
CHAPTER 7	Vehicle propulsion family and modification of vehicle model with regard to environmental performance demonstration tests	290/337

CHAPTER 8	Test type VII requirements: CO2 emissions, fuel consumption, electric energy consumption and electric range	301/337
APPENDIX 1	Method of measuring the carbon dioxide emissions, fuel consumption, electric energy consumption and driving range of vehicles powered by a hybrid electric powertrain	303/337
APPENDIX 1.1	Electrical energy/power storage device State Of Charge (SOC) profile for an Externally chargeable Hybrid Electric Vehicle (OVC HEV) in a type VII test	328/337
APPENDIX 1.2	Method for measuring the electricity balance of the battery of OVC and NOVC HEV	329/337
APPENDIX 1.3	Method of measuring the electric range of vehicles powered by an electric powertrain only or by a hybrid electric powertrain and the OVC range of vehicles powered by a hybrid electric powertrain	331/337
LIST OF ANNEXURES		
ANNEXURE 1	COMPOSITION OF AISC PANEL	336/337
ANNEXURE 2	COMMITTEE COMPOSITION	337/337

## CHAPTER 1 OVERALL REQUIREMENTS

### 1.0 SCOPE

- 1.1 This part is applicable to motor vehicles of category L2 as defined in IS 14272 as amended from time to time, equipped with positive ignition engines, compression ignition engines including hybrids electric vehicles for Bharat Stage VI.
- 1.2 This part shall be read in conjunction with Govt. Gazette Notification G.S.R. 889(E) dated 16th Sep, 2016 and as amended from time to time. Unless otherwise specified in this Part, wherever words “the notification” have been used shall mean this final gazette notification.

### 2.0 REFERENCE STANDARDS

**For the purposes of this Part the following definitions shall apply:**

- 2.1 IS – 14272- Automotive Vehicles – Types – Terminology
- 2.2 AIS – 000 - Administrative Procedure to deal with Corrigendum, Amendments or Revisions to AIS, TAP 115 /116, CMVR Notifications, IS and ISO standards, which are notified under CMVR
- 2.3 AIS – 017 - Procedure for Type Approval and Certification of Vehicles for Compliance to Central Motor Vehicles Rules.
- 2.4 IS – 2- Rules of rounding off numerical values
- 2.5 IS – 10278 - Under revision as draft TED 4 (10235)W of Oct, 2016 - Motorcycles – Method of measurement of maximum speed
- 2.6 IS – 11422- Terms and definitions of weights of Two wheeled motor vehicles

### 3 DEFINITIONS

- 3.1 For the purposes of this part the following definitions shall apply -
- 3.1.1 ‘**Actuator**’ means a converter of an output signal from a control unit into motion, heat or other physical state in order to control the powertrain, engine(s) or drive train;
- 3.1.2 ‘**Actual mass**’ in relation to a vehicle means the unladen mass, plus the mass of the rider (75 kg), plus the mass of the alternative propellant storage if applicable and plus the mass of optional equipment fitted to an individual vehicle;
- 3.1.3 ‘**Air Intake System**’ means a system composed of components allowing the fresh air charge or air-fuel mixture to enter the engine and includes, if fitted, the air filter, intake pipes, resonator(s), the throttle body and the intake manifold of an engine;



- 3.1.4 **‘Alternative Fuel Vehicle’** means a vehicle designed to run on at least one type of fuel that is either gaseous at atmospheric temperature and pressure, or substantially non- mineral oil derived;
- 3.1.5 **‘Access to OBD’** means the availability of the on-board diagnostic information laid down in Chapter 6 via the serial interface for the standard diagnostic connection, pursuant to Clause 3.12. of Appendix 1.1 and Clause 3.12. of Appendix 2.1 of Chapter 6;
- 3.1.6 **‘Axle’** means the common axis of rotation of two or more wheels whether power driven or freely rotating, and whether in one or more segments located in the same plane perpendicular to the longitudinal centre-line of the vehicle;
- 3.2.1 **‘Bi-fuel vehicle’** means a vehicle with two separate fuel storage systems that is designed to run on only one fuel at a time. The simultaneous use of both fuels is limited in amount and duration;
- 3.2.2 **‘Bi-fuel gas vehicle’** means a bi fuel vehicle that can run on petrol and also on either LPG, NG/bio methane or hydrogen (gas mode);
- 3.2.3 **‘Boost control’** means a device to control the boost level produced in the induction system of a turbocharged or supercharged engine;
- 3.3.1 **‘Calculated Load Value’** means referring to an indication of the current airflow divided by peak airflow, where peak airflow is corrected for altitude, if available. This definition provides a dimensionless number that is not engine specific and provides the service technician with an indication of the proportion of engine capacity being used (with wide open throttle as 100 %);
- 3.3.2 **‘Carburetor’** means a device that blends fuel and air into a mixture that can be combusted in a combustion engine;
- 3.3.3 **‘Catalytic Converter’** means an emission pollution control device which converts toxic by-products of combustion in the exhaust of an engine to less toxic substances by means of catalyzed chemical reactions;
- 3.3.4 **‘Catalytic Converter type’** means a category of catalytic converters that do not differ as regards the following:
- number of coated substrates, structure and material;
  - type of catalytic activity (oxidizing, three-way, or of another type of catalytic activity);
  - volume, ratio of frontal area and substrate length;
  - catalytic converter material content;
  - catalytic converter material ratio;
  - cell density;
  - dimensions and shape;
  - thermal protection;
  - an inseparable exhaust manifold, catalytic converter and muffler integrated in the exhaust system of a vehicle or separable exhaust system units that can be replaced;

- 3.3.5 **‘Compression Ignition engine’ or ‘CI engine’** means a combustion engine working according to the principles of the ‘Diesel’ cycle;
- 3.3.6 **‘Crankcase emissions’** means emissions from spaces in or external to an engine which are connected to the oil sump crankcase by internal or external ducts through which gases and vapors can escape;
- 3.3.7 **‘Conformity of production’ (CoP)** means the ability to ensure that each series of products produced is in conformity with the specification, performance and marking requirements in the type-approval;
- 3.3.8 **‘Calibration’** of the powertrain / engine or drive train control unit means the application of specific set of data maps and parameters used by the control unit’s software to tune the vehicle’s powertrain / engine or drive train;
- 3.3.9 **‘Communication protocol’** means a system of digital message formats and rules for messages exchanged in or between computing systems or units;
- 3.3.10 **‘Common rail’** means a fuel supply system to the engine in which a common high pressure is maintained;
- 3.3.11 **‘Control system’** means the electronic engine management controller and any component referred to in Chapter 6 which supplies an input to or receives an output from this controller;
- 3.3.12 **‘Cold-start device’** means a device that temporarily enriches the air/fuel mixture of the engine, thus assisting the engine to start;
- 3.3.13 **‘Circuit discontinuity’** means disconnection of only those components (sensors/actuators) which are monitored by EMS / ECU / Computer, by physically removing corresponding connector or cutting / separating wire(s) of corresponding sensor or actuator;
- 3.4.1 **‘Default mode’** refers to a case where the engine management controller switches to a setting that does not require an input from a failed component or system;
- 3.4.2 **‘Deficiency’** means, in respect of vehicle OBD systems, that up to two separate components or systems that are monitored contain temporary or permanent operating characteristics that impair the otherwise efficient OBD monitoring of those components or systems or do not meet all of the other detailed requirements for OBD;
- 3.4.3 **‘Driving cycle’** means a test type I cycle consisting of engine key-on, driving mode where a malfunction would be detected if present, and engine key -off;

- 3.4.4 **‘Defeat device’** means any element of design which senses temperature, vehicle speed, engine speed and/or load, transmission gear, manifold vacuum or any other parameter for the purpose of activating, modulating, delaying or deactivating the operation of any part of the emission control and exhaust after-treatment system and which reduces the effectiveness of the emission control system under conditions which may reasonably be expected to be encountered in normal vehicle operation and use. Such an element of design may not be considered a defeat device if:
- a) The need for the device is justified in terms of protecting the engine against damage or accident and for safe operation of the vehicle; or
  - b) The device does not function beyond the requirements of engine starting; or
  - c) Conditions are substantially included in the Type I test procedures;
- 3.4.5 **‘Drive train’** means the part of the powertrain downstream of the output of the propulsion unit(s) that consists if applicable of the torque converter clutches, the transmission and its control, either a drive shaft or belt drive or chain drive, the differentials, the final drive, and the driven wheel tyre (radius);
- 3.4.6 **‘Drive train control unit’** means the on-board computer that partly or entirely controls the drive train of the vehicle;
- 3.4.7 **‘Durability’** means the ability of components and systems to last so that the environmental performance as laid down in the notification for type I tests can still be met after a mileage as defined in Chapter 5, if the vehicle is used under normal or intended circumstances and serviced in accordance with the manufacturer’s recommendations;
- 3.4.8 **‘Degreened Vehicle’** means the test vehicle, representative of the vehicle type with regard to environmental performance to be approved. It shall be in good mechanical condition and have been run in and driven at least 1000 kms after first start on the production line.
- 3.5.1 **‘Emission control system’** means the electronic engine management controller and any emission-related component in the exhaust or evaporative system which supplies an input to or receives an output from this controller;
- 3.5.2 **‘Engine capacity’** means:
- (a) for reciprocating piston engines, the nominal engine swept volume;
  - (b) for rotary-piston (Wankel) engines, double the nominal engine swept volume;

- 3.5.3 **‘Engine control unit’** means the on-board computer that partly or entirely controls the engine or engines of the vehicle;
- 3.5.4 **‘Engine misfire’** means a lack of combustion in the cylinder of a positive-ignition engine due to the absence of spark, poor fuel metering, poor compression or any other cause; In terms of OBD monitoring, it is that percentage of misfires out of a total number of firing events (as declared by the manufacturer) that would result in emissions exceeding the limits given in the applicable Gazette Notification under CMVR or that percentage that could lead to an exhaust catalyst, or catalysts, overheating causing irreversible damage;
- 3.5.5 **‘Engine crankcase’** means the spaces in or external to an engine which are connected to the oil sump by internal or external ducts through which gases and vapour can escape;
- 3.5.6 **‘Evaporative emissions’** means the hydrocarbon vapours lost from the fuel system of a vehicle other than those from exhaust emissions meaning the hydrocarbon vapours lost from the fuel tank and fuel supply system of a motor vehicle and not those from tailpipe emissions;
- 3.5.7 **‘Exhaust emissions’** means tailpipe emissions of gaseous pollutants and particulate matter;
- 3.5.8 **‘Exhaust system’** means the combination of the exhaust pipe, the expansion box, the exhaust silencer and pollution control device(s), as applicable;
- 3.5.9 **‘Electric range’** means the distance that vehicles powered by an electric powertrain only or by a hybrid electric powertrain with off-vehicle charging can drive electrically on one fully charged battery or other electric energy storage device as measured in accordance with the procedure set out in Appendix 1-3. to Chapter 7;
- 3.5.10 **‘Electronic throttle control’** (ETC) means the control system consisting of sensing of driver input via the accelerator pedal or handle, data processing by the control unit(s), resulting actuation of the throttle and throttle position feedback to the control unit in order to control the air charge to the combustion engine;
- 3.5.11 **‘Exhaust Gas Recirculation (EGR) system’** means part of the exhaust gas flow led back to or remaining in the combustion chamber of an engine in order to lower the combustion temperature;
- 3.6.1 **‘Flex fuel vehicle’** means a vehicle with one fuel storage system that can run on different blends of two or more fuels;
- 3.6.2 **‘Flex fuel biodiesel vehicle’** means a flex fuel vehicle that can run on mineral diesel or a mixture of mineral diesel and biodiesel;
- 3.6.3 **‘Flex fuel ethanol vehicle’** means a flex fuel vehicle that can run on petrol or a mixture of petrol and ethanol up to an 85/100 per cent ethanol blend (E85/E100);

- 3.6.4 **'Fuel tank'** means a type of energy storage system that stores the fuel;
- 3.6.5 **'Fuel tank breathing losses'** means hydrocarbon emissions caused by temperature changes in the fuel tank;
- 3.6.6 **'Fuel trim'** refers to feedback adjustments to the base fuel schedule;
- 3.6.7 **'Free Acceleration Test'** means the test conducted by abruptly but not violently, accelerating the vehicle from idle to full speed with the vehicle stationary in neutral gear;
- 3.6.8 **'Flex fuel H2NG vehicle'** means a flex fuel vehicle designed to run on different mixtures of hydrogen and natural gas or bio-methane;
- 3.6.9 **'Fuel cell'** means converter of chemical energy from hydrogen into electric energy for propulsion of the vehicle;
- 3.6.10 **'Fuel feed system'** means the set of components including and between fuel storage and air-fuel blending or injecting device(s);
- 3.6.11 **'Fully Aged Golden Components'** means the pollution control devices removed from the test vehicles, after completion of full mileage accumulation according to the test procedure mentioned in Clause 3.1 of Chapter 5.
- 3.7.1 **'Gaseous pollutant'** means the exhaust gas emissions of carbon monoxide (CO), oxides of nitrogen (NO<sub>x</sub>) expressed in nitrogen dioxide (NO<sub>2</sub>) equivalent, and hydro- carbons (HC) assuming ratio of:
- (a) C<sub>1</sub>H<sub>2.525</sub> for Liquefied Petroleum Gas (LPG) ;
  - (b) C<sub>1</sub>H<sub>4</sub> for Natural Gas (NG) and biomethane ;
  - (c) C<sub>1</sub>H<sub>1.89</sub>O<sub>0.016</sub> for petrol (E5) ;
  - (d) C<sub>1</sub>H<sub>1.93</sub>O<sub>0.033</sub> for petrol (E10);
  - (e) C<sub>1</sub>H<sub>1.86</sub>O<sub>0.007</sub> for diesel (B7) ;
  - (f) C<sub>1</sub>H<sub>2.74</sub>O<sub>0.385</sub> for ethanol (E85);
  - (g) C<sub>2</sub>H<sub>5</sub>OH for ethanol (E100);
  - (h) C<sub>2</sub>H<sub>5</sub>OH for ethanol (E100);
- 3.8.1 **'Hot soak losses'** means hydrocarbon emissions arising from the fuel system of a stationary vehicle after a period of driving (assuming a ratio of C<sub>1</sub>H<sub>2.20</sub>);
- 3.8.2 **'Hybrid vehicle (HV)'** means a vehicle with at least two different energy converters and two different energy storage systems (on vehicle) for the purpose of vehicle propulsion;

- 3.8.3 **‘Hybrid electric vehicle (HEV)’** means a vehicle that, including vehicles which draw energy from a consumable fuel only for the purpose of recharging the electrical energy/power storage device that, for the purpose of mechanical propulsion, draws energy from both of the following on-vehicle sources of stored energy/power:
- a) A consumable fuel;
  - b) A battery, capacitor, flywheel/generator or other electrical energy/power storage device;
- 3.9.1 **‘Inlet conduit’** means the combination of the inlet passage and the intake pipe;
- 3.9.2 **‘Inlet passage’** means the passage for the intake of air within the cylinder, cylinder-head or crankcase;
- 3.9.3 **‘Intake pipe’** means a part connecting the carburettor or air-control system and the cylinder, cylinder-head or crankcase;
- 3.9.4 **‘Intake system’** means the combination of the inlet conduit and the intake silencer;
- 3.9.5 **‘Intercooler’** means a heat exchanger that removes waste heat from the compressed air by a charger before entering into the engine, thereby improving volumetric efficiency by increasing intake air charge density;
- 3.10.1 **‘Lean NO<sub>x</sub> absorber’** means a storage of NO<sub>x</sub> fitted into the exhaust system of a vehicle which is purged by the release of a reactant in the exhaust flow;
- 3.10.2 **‘Long-term fuel trim’** refers to much more gradual adjustments to the fuel calibration schedule which compensate for vehicle differences and gradual changes that occur over time;
- 3.10.3 **‘Limp-home’** means an operation mode triggered by the control system that restricts fuel quantity, intake air quantity, spark delivery or other powertrain control variables resulting in significant reduction of output torque or engine revolution or vehicle speed;
- 3.11.1 **‘Mono-fuel vehicle’** means a vehicle that is designed to run primarily on one type of fuel;
- 3.11.2 **‘Mono-fuel gas vehicle’** means a vehicle that is designed primarily for permanent running on LPG or NG/bio methane or hydrogen, but may also have a petrol system for emergency purposes or starting only, where the petrol tank does not contain more than 2 litres of petrol;
- 3.11.3 **‘Mode Switch’** means a mechanical switch which enables the user to select one of the operating modes available in the vehicle for example “economic mode”, “Power mode”, “EV mode”, “Engine Mode” etc;

- 3.11.4 **‘Malfunction Indicator (MI)’** means a visible indicator that clearly informs the driver of the vehicle in the event of malfunctions;
- 3.11.5 **‘Malfunction’** means the failure of an electric /electronic circuit referred to in Chapter 6;
- 3.11.6 **‘Mass of the optional equipment’** means the mass of the equipment which may be fitted to the vehicle in addition to the standard equipment, in accordance with the manufacturer’s specifications;
- 3.11.7 **‘Maximum net power’** means the maximum output for that power measured under full engine load;
- 3.11.8 **‘Maximum torque’** means the maximum torque value measured under full engine load;
- 3.11.9 **‘Mesh size’** means the number of openings per (linear) inch of mesh;
- 3.11.10 **‘Mileage accumulation’** means a representative test vehicle or a fleet of representative test vehicles driving a predefined distance as set out in the notification in accordance with the test requirements of Chapter 5 to this standard;
- 3.12.1 **‘Net power’** means the power obtained on the test bench at the end of the crankshaft or its equivalent at the speed laid down by the manufacturer, together with the accessories listed AIS 137 part 5 If the power can be measured only when a gearbox is attached to the engine, the efficiency of the gearbox shall be taken into account;
- 3.12.2 **‘Non-exposed’** type of fuel tank means that the fuel tank, except the fuel tank cap, is not directly exposed to radiation of sunlight;
- 3.13.1 **‘Optional equipment’** means features that are not included in the standard equipment and may be fitted to a vehicle under the responsibility of the manufacturer;
- 3.13.2 **‘Opacity Meter’** means an Instrument for continuous measurement of the light absorption coefficient of the exhaust gases emitted by vehicles;
- 3.13.3 **‘OVC range’** means the total distance covered during complete combined cycles run until the energy imparted by external charging of the battery (or other electric energy storage device) is depleted, as measured in accordance with the procedure described in Appendix 3.3. to Chapter 8;
- 3.13.4 **‘On-Board Diagnostic system (OBD)’** means an electronic system fitted on-board of a vehicle that has the capability of identifying the likely area of malfunction by means of fault codes stored in a computer memory which can be accessed by means of a generic scan tool;
- 3.14.1 **‘Parent vehicle’** means a vehicle that is representative of a propulsion family set out in Chapter 7;

- 3.14.2 **‘Particulate filter’** means a filtering device fitted in the exhaust system of a vehicle to reduce particulate matter from the exhaust flow;
- 3.14.3 **‘Particulate matter’** means components of the exhaust gas which are removed from the diluted exhaust gas at a maximum temperature of 52°C by means of the filters described in the test procedure for verifying average tailpipe emissions;
- 3.14.4 **‘Periodically regenerating system’** means a pollution control device such as a catalytic converter, particulate filter or any other pollution control device that requires a periodical regeneration process in less than 4,000 km of normal vehicle operation;
- 3.14.5 **‘Pollution control device’** means those components of a vehicle that control or reduce tailpipe and/or evaporative emissions;
- 3.14.6 **‘Pollution control device type’** means a category of pollution-control devices that are used to control pollutant emissions and that do not differ in their essential environmental performance and design characteristics;
- 3.14.7 **‘Positive ignition engine’** or **‘PI engine’** means a combustion engine working according to the principles of the ‘Otto’ cycle;
- 3.14.8 **‘Powertrain control unit’** means a combined control unit of combustion engine(s), electric traction motors or drive train unit systems including the transmission or the clutch;
- 3.14.9 **‘Propulsion unit performance type-approval’** of a vehicle means the approval of a vehicle type, variant or version with regard to the performance of the propulsion units as regards the following conditions:
- the maximum design vehicle speed(s);
  - the maximum continuous rated torque or maximum net torque;
  - the maximum continuous rated power or the maximum net power;
- The maximum total torque and power in the case of a hybrid application;
- 3.14.10 **‘Properly maintained and used’** means that when selecting a test vehicle it satisfies the criteria with regard to a good level of maintenance and normal use according to the recommendations of the vehicle manufacturer for acceptance of such a test vehicle;
- 3.14.11 **‘Propulsion’** means a combustion engine, an electric motor, any hybrid application or a combination of those engine types or any other engine type;
- 3.14.12 **‘Permanent default mode’** refers to a case where the engine management controller permanently switches to a setting that does not require an input from a failed component or system;



- 3.14.13 **‘Power take-off unit’** means an engine-driven output provision for the purposes of powering auxiliary, vehicle mounted equipment;
- 3.14.14 **‘Partially Aged Golden Components’** means the pollution control devices removed from the test vehicles, after completion of partial mileage accumulation according to the test procedure mentioned in Clause 3.2 of Chapter 5.
- 3.14.15 **‘Pay-mass’** means the difference between the technically permissible maximum laden mass and the actual mass of the vehicle;
- 3.15.1 **‘Repair information’** means all information required for diagnosis, servicing, inspection, periodic monitoring or repair of the vehicle and which the manufacturers provide for their authorized dealers/repair shops or for manufacturers of replacement or retrofit components which are compatible with the vehicle OBD system. Where necessary, such information shall include service handbooks, technical manuals, diagnosis information (e.g. minimum and maximum theoretical values for measurements), wiring diagrams, the software calibration identification number applicable to a vehicle type, instructions for individual and special cases, information provided concerning tools and equipment, data record information and bi-directional conformity and test data. The manufacturer shall also make accessible, where appropriate on payment, the technical information required for the repair or maintenance of motor vehicles unless that information is covered by an intellectual property right or constitutes essential, secret know-how which is identified in an appropriate form; in such case, the necessary technical information shall not be withheld improperly;
- 3.15.2 **‘Rechargeable energy storage system (REESS)’** means the rechargeable energy storage system that provides electric energy for electrical propulsion. The REESS may include subsystem(s) together with the necessary ancillary systems for physical support, thermal management, electronic control and enclosures;
- 3.15.3 **‘Reference mass’** means the mass in running order /unladen mass as determined in accordance with IS 11422: 2001 as amended by time to time, increased with the mass of the rider (75 kg) and if applicable plus the mass of the propulsion battery;
- 3.16.1 **‘Scavenging port’** means a connector between crankcase and combustion chamber of a two-stroke engine through which the fresh charge of air, fuel and lubrication oil mixture enters the combustion chamber;
- 3.16.2 **‘Secondary air’** means air introduced into the exhaust system by means of a pump or aspirator valve or other means intended to aid in the oxidation of HC and CO contained in the exhaust gas flow;
- 3.16.3 **‘Sensor’** means a converter that measures a physical quantity or state and converts it into an electric signal that is used as input to a control unit;

- 3.16.4 **‘Series mounted equipment’** means all equipment intended by the manufacturer for a specific application;
- 3.16.5 **‘Short-term fuel trim’** refers to dynamic or instantaneous adjustments to the base fuel schedule;
- 3.16.6 **‘Significant reduction of propulsion torque’** means a propulsion torque less than or equal to 90 % of torque in normal operation mode;
- 3.16.7 **‘Spark delivery of the ignition system’** means all the characteristics of the spark generated in the ignition system of a positive ignition ‘(PI)’ engine used to ignite the air-fuel mixture, such including timing, level and positioning;
- 3.16.8 **‘Smoke Density’** means the light absorption coefficient of the exhaust gases emitted by the vehicle expressed in terms of m-1 or in other units such as Bosch, Hartridge, % opacity etc;
- 3.16.9 **‘Standard equipment’** means the basic configuration of a vehicle equipped with all the features required under the regulatory acts referred to in CMVR, including all features that are fitted without giving rise to any further specifications on configuration or equipment level;
- 3.16.10 **‘Stop-Start system’** means automatic stop and start of the propulsion unit to reduce the amount of idling, thereby reducing fuel consumption, pollutant and CO<sub>2</sub> emissions of the vehicle;
- 3.16.11 **‘Super-charger’** means an intake air compressor used for forced induction of a combustion engine, thereby increasing propulsion unit performance;
- 3.16.12 **‘SCR system’** means a system capable of converting gaseous pollutants into harmless or inert gases by injecting a consumable reagent, which is a reactive substance to reduce tailpipe emissions and which is adsorbed onto a catalytic converter;
- 3.16.13 **‘SHED test’** means a vehicle test in a sealed house for evaporation determination, in which a special evaporative emission test is conducted;
- 3.16.14 **‘Standardised data’** means that all data stream information, including all diagnostic trouble codes used, is produced only in accordance with industry standards which, by virtue of the fact that their format and their permitted options are clearly defined, provide for a maximum level of harmonization in the industry developing and producing vehicles, and the use of which is expressly permitted in this part ;
- 3.16.15 **‘Software’** of the powertrain / engine or drive train control units means a set of algorithms concerned with the operation of powertrain, engine or drive train data processing systems, containing an ordered sequence of instructions that change the state of the powertrain, engine or drive train control unit;
- ‘Software Identification Number’** refers to Calibration identification number;

- 3.16.16 **‘Starting aid’** means a device which assists engine start up without enrichment of the air/fuel mixture such as glow plugs, injection timing and spark delivery adaptations;
- 3.17.1 **‘Tailpipe Emissions’** means the emission of gaseous pollutants and particulate matter at the tailpipe of the vehicle;
- 3.17.2 **‘Torque’** means the torque measured under the conditions specified in Part 5 of AIS 137;
- 3.17.3 **‘Turbocharger’** means an exhaust gas turbine-powered centrifugal compressor boosting the amount of air charge into the combustion engine, thereby increasing propulsion unit performance;
- 3.17.4 **‘Technically permissible maximum laden mass’ (M)** means the maximum mass allocated to a vehicle on the basis of its construction features and design performances;
- 3.17.5 **‘Technically permissible maximum towable mass’ (TM)** means the maximum mass capable of being towed by a towing vehicle;
- 3.18.1 **‘Unrestricted access to the OBD system’** means:
- (a) Access not dependent on an access code obtainable only from the manufacturer, or a similar device; or
  - (b) Access allowing evaluation of the data produced without the need for any unique decoding information, unless that information itself is standardized information;
- 3.18.2 **‘Useful life for evaporative system’** means the relevant period of distance and/or time over which compliance with the evaporative total hydrocarbon emission limits has to be assured;
- ‘Useful life for OBD’** means the relevant period of distance and/or time over which compliance with the OBD system has to be assured;
- 3.19.3 **‘Vehicle propulsion unit family’** for the purpose of this part of the standard means a manufacturers grouping of vehicles which, through their design as defined in Chapter 7 of this Standard, have similar Environmental and Propulsion Unit Performance characteristics;
- 3.19.4 **‘Variable cam phasing or lift’** means allowing the lift, the opening and closing duration or timing of the intake or exhaust valves to be modified while the engine is in operation;
- 3.20.1 **‘Warm-up cycle’** means sufficient vehicle operation such that the coolant temperature rises by at least 22 °C from engine start-up to at least 70 °C. If this condition is insufficient to determine the warm up cycle, with the permission of the test agency, alternative criteria and/or alternative signal(s) or information (e.g. spark plug seat temperature, engine oil temperature, vehicle operation time, accumulative engine revolution, travel distance, etc.) may be adopted. In any case, all signal(s) and information used for determination need to be monitored by the ECU and shall be made available by data stream;

- 3.2 For definitions related to Type Approval terminologies i.e. base vehicle, vehicle type, variant(s) etc. the definitions given in AIS-017 shall apply.

#### **4.0 REQUIREMENTS**

This part establishes the administrative and technical requirements for the type-approval of new types of vehicles, systems, components and separate technical units referred to in clause 1 of this Chapter.

- 4.1 However, the test requirements are not applicable in petrol mode for a vehicle in the scope of this part that is designed primarily for permanent running on gaseous fuel, having a petrol system, with a petrol fuel tank capacity not exceeding two liters in the case of vehicles of L2 category, intended for emergency purposes or starting only or limp home mode.
- 4.2 L2 category of vehicles shall be manufactured to comply with the requirements specified in the notification throughout the useful life specified therein when maintained as per the recommendations of the vehicle manufacturer. This requirement shall be deemed to be satisfied when the vehicles are tested for specified tests as per the procedures mentioned in this part.
- 4.3 For the purpose of classification of vehicle for deciding the applicable test cycle and weighting factors as defined in the notification, the maximum speed shall be taken as the maximum speed declared by the manufacturer. However, in case of border line cases, testing agencies may decide to measure the maximum speed which shall be, when tested as per IS: 10278-2009, as amended from time to time, within the tolerance specified in the standard.

**Note:** Till such time the standard is finalized, test shall be carried out as per IS: 10278-2009 and measured max speed shall be within  $\pm 5\%$ .

- 4.4 For CNG and LPG vehicles, the provisions of CMV Rule 115(B) and CMV Rule 115(C), as amended from time to time shall apply respectively.

THC will be measured wherever NMHC & RHC (Reactive Hydrocarbon) appears for BS VI.

- 4.5 **AIS-137 (Part 5)** specifies the method for measurement of performance such as net power at the end of the crankshaft or its equivalent at the corresponding engine or motor speed with the auxiliaries.

This method can be used to verify specific performance parameter against that claimed by the manufacturers, as required for statutory purposes as part of type approval.

**5.0 APPLICATION FOR TYPE APPROVAL**

Application for Type Approval shall be submitted to the test agency along with following: -

5.1 Information to be submitted at the time of application for type approval shall be as given in AIS-007 as amended from time to time.

In addition, the manufacturer shall submit the following information:

- (a) In the case of vehicles equipped with positive-ignition engines, a declaration by the manufacturer of the minimum percentage of misfires out of a total number of firing events that would either result in emissions exceeding the limits given in applicable Gazette Notification, if that percentage of misfire had been present from the start of a Type I test as described in Chapter 2 of this Part, or that could lead to an exhaust catalyst, or catalysts, overheating prior to causing irreversible damage;
- (b) Detailed written information fully describing the functional operation characteristics of the OBD system, including a listing of all relevant parts of the emission control system of the vehicle that are monitored by the OBD system;
- (c) A description of the malfunction indicator used by the OBD system to signal the presence of a fault to a driver of the vehicle;
- (d) A declaration by the manufacturer that the OBD system complies with the provisions of Chapter 6 of this Part relating to in-use performance under all reasonably foreseeable driving conditions;
- (e) A description of the provisions taken to prevent tampering with and modification of the emission control computer;
- (f) If applicable, the particulars of the vehicle family as referred to in Chapter 7 of this Part;
- (g) Where appropriate, copies of other type approvals with the relevant data to enable extension of approvals and establishment of deterioration factors.

**Note:** If the above information is submitted in a consolidated form for type approval of the whole vehicle as per AIS-007 as amended from time to time, it is not necessary to submit this information again.

5.2 Number of vehicles to be submitted for Type approval shall be worked out by the manufacturer based on the family definition mentioned in Chapter 7 of this Part.

5.3 This may also necessitate submission of vehicles of different variant (s) for each test.

- 5.4 A copy of Owner's manual and service station manual shall be submitted to the test agency. Any changes to this document shall be communicated to the test agency from time to time.

**Note:** In case these publications are not available at the time of submitting the prototype vehicle, they shall be submitted by the manufacturer as and when they are ready but before first COP. In case these publications are not available at the time of prototype testing, the relevant information required by the testing agency, shall be provided by the manufacturer.

## **6.0 TYPE APPROVAL**

- 6.1 If the vehicle submitted for approval pursuant to this part of the standard meets all the specified requirements, approval of that vehicle type shall be granted in the form as mentioned in AIS 017.

## **7.0 EXTENSION OF TYPE APPROVAL**

- 7.1 Every functional modification in technical specifications pertaining to Environmental and Propulsion performance of vehicle declared as per AIS 007 as amended from time to time for BS VI provisions shall be intimated to the testing agency.

Testing agency may then consider, whether,

- 7.1.1 Vehicle with modifications complies with specified requirements
- 7.1.2 Any testing is required.
- 7.2 For considering whether testing is required or not, guidelines given in Chapter 7 of this Part shall be followed.
- 7.3 In case of 7.1.2, above checks for those parameters which are affected by the modifications only need to be carried out.
- 7.4 In the event of 7.1.1, above (or in the case of 7.1.2, above) after successful compliance to requirements, the certificate of compliance shall be extended for the modified version.
- 7.5 In case these changes necessitate amendments in the Owners' manual and Service station manual, the amended copies shall be submitted to the test agency.
- 7.6 Any changes to the procedure of PDI and running in concerning emission shall also be intimated to the test agency by the vehicle manufacturer, whenever such changes are carried out.

## **8.0 TRANSITORY PROVISIONS ( Refer AIS-000)**

- 8.1 At the request of the applicant, type approvals for compliance to BS VI norms as per CMVR no 115 (19(i)) shall be granted by test agencies from date of the Notification. Such type approvals shall be deemed to be compliance to BS IV norms as per CMVR no 115 (16).

- 8.1.1 However, in such cases the extension of approval for design changes and Conformity of Production, if applicable, shall be as per BS VI norms as per CMVR no 115 (19(i))
- 8.2 At the request of applicant, type approval to BS IV norms as per CMVR no 115 (16) shall be granted up to the notified date of implementation of BS VI norms as per CMVR no 115 (19(i)).
- 8.3 Type approvals issued for compliance to BS IV norms as per CMVR No 115 (16) shall be extended for design changes till implementation date of BS VI norms as per CMVR no 115 (19(i)) subject to satisfactory compliance.
- 8.4 Type approvals granted to OBD stage I as per CMVR no 115 (19) (i) shall be extended for design changes till implementation date of OBD stage II.
- 9.0 ESSENTIAL CHARACTERISTICS OF THE VEHICLE AND ENGINE AND INFORMATION CONCERNING THE CONDUCT OF TESTS:**
- 9.1 Information applicable to the vehicle category shall be provided as per respective Tables in AIS-007, as amended from time to time.

**Table 1**  
**Application of Test Requirements for Type-Approval: BS-VI ( Refer Gazette Notification)**

	Vehicle with SI engines including hybrids									Vehicles with CI engines including hybrids		
	Mono-fuel					Bi-fuel <sup>(3)</sup>			Flex fuel	Flex-fuel	Mono-fuel	Dual Fuel
	Gasoline (E5)	LPG	CNG/Bio methane/ Bio-Gas/LNG	H <sub>2</sub>	HCNG (Hydrogen + CNG)	Gasoline (E5)	Gasoline (E5)	Gasoline (E5)	Gasoline (E5)	Diesel (B7)	Diesel (B7)	Diesel + CNG
LPG						CNG/Bio methane	H <sub>2</sub>	Ethanol (E85)/ E100	Up to 100% <sup>(1)</sup> Biodiesel			
Gaseous pollutant (Type I)	Yes	Yes	Yes	Yes	Yes	Yes (both fuels)	Yes (both fuels)	Yes (both fuels)	Yes (both fuels)	Yes (both fuels)	Yes	Yes
<sup>(2)</sup> Type I test Particulate mass	Yes	No	No	No	No	Yes (gasoline only)	Yes (gasoline only)	Yes (gasoline only)	Yes (gasoline only)	Yes	Yes	Yes
Idle emission (Type II)	Yes	Yes	Yes	No	Yes	Yes (both fuels)	Yes (both fuels)	Yes (gasoline only)	Yes (both fuels)	Yes (B7 only)	Yes	Yes
Crankcase emission (Type III)	Yes	Yes	Yes	Yes	Yes	Yes	Yes	Yes	Yes	Yes	Yes	Yes
Evaporative emission (Type IV)	Yes	No	No	No	No	Yes (gasoline only)	Yes (gasoline only)	Yes (gasoline only)	Yes (gasoline only)	No	No	No
Durability (Type V)	Yes	Yes	Yes	Yes	Yes	Yes (gasoline only)	Yes (gasoline only)	Yes (gasoline only)	Yes (gasoline only)	Yes (B7 only)	Yes	Yes
<sup>(4)</sup> CO <sub>2</sub> & Fuel Consumption	Yes	Yes	Yes	Yes	Yes	Yes (both fuels)	Yes (both fuels)	Yes (both fuels)	Yes (both fuels)	Yes (both fuels)	Yes	Yes
On Board Diagnosis OBD	Yes	Yes	Yes	Yes	Yes	Yes (gasoline only)	Yes (gasoline only)	Yes (gasoline only)	Yes (gasoline only)	Yes (B7 only)	Yes	Yes
Smoke Opacity	No	No	No	No	No	No	No	No	No	Yes (B7 only)	Yes	No

- (1) Vehicles fuelled with bio diesel blends up to 7% shall be tested with reference diesel (B7) and vehicles fuelled with Biodiesel blends above 7% will be tested with respective blends.
- (2) In case of PI engines, applicable only to vehicles with direct Injection engines.
- (3) Vehicles models and variants having option for Bi-fuel operation and fitted with limp-home gasoline tank of capacity not exceeding two litres on two wheelers shall be exempted from test in gasoline mode.
- (4) CO<sub>2</sub> emission and fuel consumption shall be measured as per procedure laid down in AIS-137 and as amended time to time. When bi-fuel vehicle is combined with a flex fuel vehicle, both test requirements are applicable. Vehicle tested with E100 need not to be tested with E85.



**Table 2**  
**Classification of Vehicles and weighing Factor**

Sr. No.	Class	Definition of class	WMTC Cycles	Weighting factors for final emission results
(1)	(2)	(3)	(4)	(5)
1.	Class 1	Vehicles that fulfill the following specifications belong to class1 $50 \text{ cm}^3 < \text{engine capacity} < 150 \text{ cm}^3$ and $V_{\text{max}} \leq 50 \text{ km/h}$ or Engine capacity $< 150 \text{ cm}^3$ and $50 \text{ km/h} < V_{\text{max}} < 100 \text{ km/h}$	Part 1 Reduced Speed cold followed by Part 1 Reduced Speed Hot	Part 1 Reduced Speed cold shall be 50% and Part 1 Reduced Speed Hot shall be 50%
2.	Sub-Class 2-1	Vehicles that fulfill the following specifications belong to class2-1: Engine capacity $< 150 \text{ cm}^3$ and $100 \text{ km/h} \leq V_{\text{max}} < 115 \text{ km/h}$ or Engine capacity $\geq 150 \text{ cm}^3$ and $V_{\text{max}} < 115 \text{ km/h}$	Part 1 Reduced Speed cold followed by Part 2 Reduced Speed Hot	Part 1 Reduced Speed cold shall be 50% and Part 2 Reduced Speed Hot shall be 50%
3.	Sub-Class 2-2	Vehicles that fulfill the following specifications belong to class 2-2 $115 \text{ km/h} \leq V_{\text{max}} < 130 \text{ km/h}$ .	Part 1 cold followed by Part 2 Hot	Part 1 cold shall be 50% and Part 2 hot shall be 50%.
4.	Sub-Class 3-1	Vehicles that fulfill the following specifications belong to class2-2 class3-1: $130 \text{ km/h} \leq V_{\text{max}} < 140 \text{ km/h}$	Part 1 cold followed by Part 2 Hot followed by Part 3 reduced speed	Part 1 cold shall be 25% Part 2 Hot shall be 50% and Part 3 reduced shall be 25%
5.	Sub-Class 3-2	Vehicles that fulfill the following specifications belong to class2-2 class 3-2: $V_{\text{max}} \geq 140 \text{ km/h}$ .	Part 1 cold followed by Part 2 Hot followed by Part 3	Part 1 cold shall be 25% Part 2 Hot shall be 50% and Part 3 shall be 25%

**CHAPTER 2****TYPE I TESTS-TAILPIPE EMISSIONS AFTER COLD START****1.0 INTRODUCTION**

- 1.1. This Chapter sets out the procedure for type I test of L2 Category vehicle as defined in AIS-053/ IS 14272 as amended from time to time, for verifying compliance to tailpipe emission norms for BS-VI.

**2.0 GENERAL REQUIREMENTS:**

- 2.1. The components liable to affect the emission of gaseous pollutants, carbon dioxide emissions and fuel consumption shall be so designed, constructed and assembled so as to enable the vehicle in normal use, despite the vibration to which it may be subjected, to comply with the provisions of this Chapter.
- 2.2. Any hidden strategy that ‘optimizes’ the power train of the vehicle running in the relevant emission laboratory test cycle in an advantageous way, reducing tailpipe emissions and running significantly differently under real-world conditions, is considered a defeat strategy and is prohibited, unless the manufacturer has documented and declared it to the satisfaction of the test agency.

**3.0 PERFORMANCE REQUIREMENTS**

The vehicle shall comply with the applicable limits as specified in the notification.

**4.0 TEST CONDITIONS****4.1. Test room and soak area****4.1.1. Test room**

The test room with the chassis dynamometer and the gas sample collection device shall have a temperature of  $25 \pm 5^\circ\text{C}$ . The room temperature shall be measured in the vicinity of the vehicle cooling blower (fan) before and after the type I test. The absolute humidity (H) of either the air in the test cell or the intake air of the engine shall be such that  $5.5 < H < 12.2 \text{ g H}_2\text{O/kg dry air}$ .

**4.1.2. Soak area**

The soak area shall have a temperature of  $25 \pm 5^\circ\text{C}$  and be such that the test vehicle to be preconditioned can be parked in accordance with clause 5.2.4 of this Chapter.

**4.2. Test vehicle****4.2.1. General**

All components of the test vehicle shall conform to those of the production series or, if the vehicle is different from the production series, a full description shall be given in the test report. In selecting the test vehicle, the manufacturer and the test agency shall agree to which vehicle test model representative of vehicle propulsion family as is laid down in Chapter 7 of this Part.

**4.2.2. Run-in**

The vehicle shall be presented in good mechanical condition, properly maintained and used. It shall have been run in and driven at least 1000 km before the test. The engine, drive train and vehicle shall be properly run in, in accordance with the manufacturer's requirements.

**Note:** If the manufacturer has carried out the run-in on a chassis dynamometer where the odometer does not get operated, a declaration by the manufacturer will be sufficient for the compliance to this clause. However, the test agency may seek for log data by the manufacturer.

**4.2.3. Adjustments**

The test vehicle shall be adjusted in accordance with the manufacturer's requirements, e.g. as regards the viscosity of the oils, or, if the test vehicle is different from the production series, a full description shall be given in the test report.

**4.2.4. Test mass and load distribution**

The test mass, including the masses of the rider and the instruments, shall be measured before the beginning of the tests. The load shall be distributed across the wheels as specified by the manufacturer.

**4.2.5. Tyres**

The tyres shall be of a type specified as original equipment by the vehicle manufacturer. The tyre pressures shall be adjusted to the specifications of the manufacturer or to those where the speed of the vehicle during the road test and the vehicle speed obtained on the chassis dynamometer are equalized. The tyre pressure shall be indicated in the test report.

**4.3. Vehicle sub-classification:** the vehicle sub classification shall be as given in the notification and Table 2 of Chapter 1 of this part. The numerical value of the engine capacity and maximum vehicle speed shall not be rounded up or down as per IS 2 and IS 10278 as amended from time to time, respectively.

**4.4. Specification of the reference fuel**

The reference fuel as prescribed in the notification shall be used. If the engine is lubricated by a fuel oil mixture, the oil added to reference fuel shall comply with the grade and quantity as per the manufacturer's recommendation. The same shall be reported and indicated in test report.

**4.5. Type I test****4.5.1. Rider**

The test rider shall have a mass of  $75 \pm 5$  kg.

**4.5.2. Test bench specifications and settings**

- 4.5.2.1. The dynamometer shall have a single roller or two rollers/long single roller in case of vehicles with twinned wheel, with a diameter of at least 400 mm
- 4.5.2.2. The dynamometer shall be equipped with a roller revolution counter for measuring actual distance travelled.
- 4.5.2.3. Dynamometer flywheels or other means shall be used to simulate the inertia specified in clause 5.2.2 of this Chapter.
- 4.5.2.4. The dynamometer rollers shall be clean, dry and free from anything which might cause the tyre to slip.

The setting of the dynamometer shall not be affected by the lapse of time. It shall not produce any vibrations perceptible to the vehicle and likely to impair the vehicle's normal operations.

4.5.2.5. **Cooling fan specifications as follows:**

- 4.5.2.5.1. Throughout the test, a variable-speed cooling blower (fan) shall be positioned in front of the vehicle so as to direct the cooling air onto it in a manner that simulates actual operating conditions. The blower speed shall be such that, within the operating range of 10 to 50 km/h, the linear velocity of the air at the blower outlet is within  $\pm 5$  km/h of the corresponding roller speed. At the range of over 50 km/h, the linear velocity of the air shall be within  $\pm 10$  percent. At roller speeds of less than 10 km/h, air velocity may be zero.
- 4.5.2.5.2. The air velocity referred to in clause 4.5.2.5.1 of this Chapter shall be determined as an averaged value of nine measuring points which are located at the Centre of each rectangle dividing the whole of the blower outlet into nine areas (dividing both horizontal and vertical sides of the blower outlet into three equal parts). The value at each of the nine points shall be within 10 percent of the average of the nine values.
- 4.5.2.5.3. The blower outlet shall have a cross-section area of at least 0.4 m<sup>2</sup> and the bottom of the blower outlet shall be between 15 and 20 cm above floor level. The blower outlet shall be perpendicular to the longitudinal axis of the vehicle, between 30 and 45 cm in front of its front wheel. The device used to measure the linear velocity of the air shall be located in the middle of the stream at 20 cm away from the air outlet.
- 4.5.2.6. The detailed requirements regarding test bench specifications are listed in Appendix 3 of this Chapter.

4.5.3. **Exhaust gas measurement system**

- 4.5.3.1. The gas-collection device shall be closed-type device that can collect all exhaust gases at the vehicle exhaust outlets on condition that it satisfies the backpressure condition of  $\pm 125$  mm of H<sub>2</sub>O. An open system may be used if it is confirmed that all the exhaust gases are collected. The gas collection shall be such that there is no condensation which could appreciably modify the nature of exhaust gases at the test temperature. An example of a gas-collection device is illustrated in Figure 1 & Figure 2 of this Chapter.

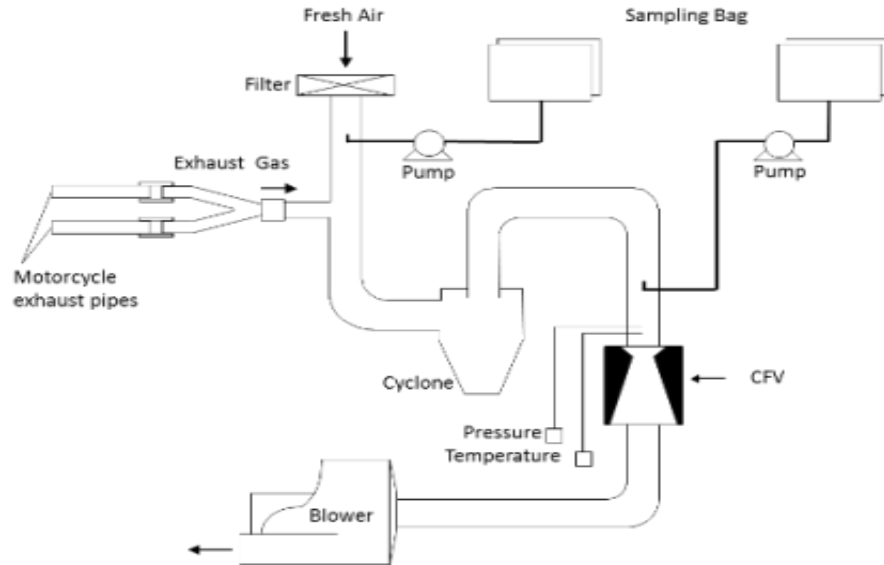

**Figure 1**

An example of closed-type system for sampling gases and measuring their volume

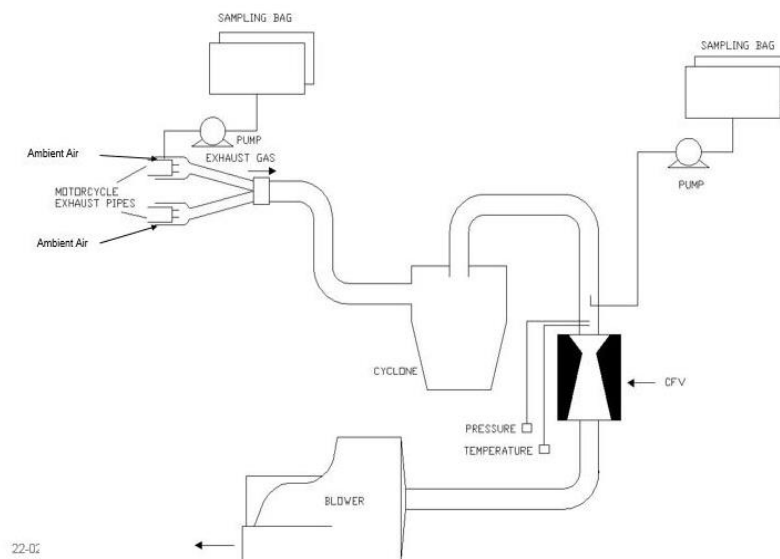

**Figure 2**

An example of open-type system for sampling gases and measuring their volume.

- 4.5.3.2. A connecting tube shall be placed between the device and the exhaust gas sampling system. This tube and the device shall be made of stainless steel, or of some other material which does not affect the composition of the gases collected and which withstands the temperature of these gases.
- 4.5.3.3. A heat exchanger capable of limiting the temperature variation of the diluted gases in the pump intake to  $\pm 5\text{K}$  ( $\pm 5^\circ\text{C}$ ) shall be in operation throughout the test. This exchanger shall be equipped with a preheating

system capable of bringing the exchanger to its operating temperature (with the tolerance of  $\pm 5\text{K}$  ( $\pm 5^\circ\text{C}$ ) before the test begins.

- 4.5.3.4. A positive displacement pump shall be used to draw in the diluted exhaust mixture. This pump shall be equipped with a motor with several strictly controlled uniform speeds. The pump capacity shall be large enough to ensure the intake of the exhaust gases. A device using a critical-flow venturi (CFV) may also be used.
- 4.5.3.5. A device (T) shall be used for the continuous recording of the temperature of the diluted exhaust mixture entering the pump.
- 4.5.3.6. Two gauges shall be used, the first to ensure the pressure depression of the dilute exhaust mixture entering the pump relative to atmospheric pressure, and the second to measure the dynamic pressure variation of the positive displacement pump.
- 4.5.3.7. A probe shall be located near to, but outside, the gas-collecting device, to collect samples of the dilution air stream through a pump, a filter and a flow meter at constant flow rates throughout the test.
- 4.5.3.8. A sample probe pointed upstream into the dilute exhaust mixture flow, upstream of the positive displacement pump, shall be used to collect samples of the dilute exhaust mixture through a pump, a filter and a flow meter at constant flow rates throughout the test. The minimum sample flow rate in the sampling devices shown in Figure 2 of this Chapter and in clause 4.5.3.7 of this Chapter shall be at least 150litre/hour.
- 4.5.3.9. Three-way valves shall be used on the sampling system described in clauses 4.5.3.7 and 4.5.3.8 of this Chapter to direct the samples either to their respective bags or to the outside throughout the test.
- 4.5.3.10. **Gas-tight collection bags**
- 4.5.3.10.1. For dilution air and dilute exhaust mixture the collection bags shall be of sufficient capacity not to impede normal sample flow and shall not change the nature of the pollutants concerned.
- 4.5.3.10.2. The bags shall have an automatic self-locking device and shall be easily and tightly fastened either to the sampling system or the analyzing system at the end of the test.
- 4.5.3.11. A revolution counter shall be used to count the revolutions of the positive displacement pump throughout the test.

**Note:** With open type devices, there is a risk of incomplete gas collection and gas leakage into the test cell. There shall be no leakage throughout the sampling period.

**Note:** If a constant volume sampler (CVS) flow rate is used throughout the test cycle that includes low and high speeds all in one (i.e. part 1, 2 and 3 cycles), special attention shall be paid to the higher risk of water condensation in the high speed range.

- 4.5.3.12 **Particulate mass emissions measurement equipment**
- 4.5.3.12.1 **Specification**
- 4.5.3.12.1.1. **System overview**
- 4.5.3.12.1.1.1. The particulate sampling unit shall consist of a sampling probe located in the dilution tunnel, a particle transfer tube a filter holder a partial-flow pump, and flow rate regulators and measuring units.
- 4.5.3.12.1.1.2. It is recommended that a particle size pre-classifier (e.g. cyclone or impactor) be employed upstream of the filter holder. However, a sampling probe, used as an appropriate size-classification device such as that shown in Figure 7 of this Chapter, is acceptable.
- 4.5.3.12.1.2. **General requirements**
- 4.5.3.12.1.2.1. The sampling probe for the test gas flow for particulates shall be so arranged within the dilution tract that a representative sample gas flow can be taken from the homogeneous air/exhaust mixture.
- 4.5.3.12.1.2.2. The particulate sample flow rate shall be proportional to the total flow of diluted exhaust gas in the dilution tunnel within a tolerance of  $\pm 5$  percent of the particulate sample flow rate.
- 4.5.3.12.1.2.3. The sampled dilute exhaust gas shall be maintained at a temperature above 20°C below 52°C within 20 cm upstream or downstream of the particulate filter face except in the case of a regeneration test, where the temperature shall be below 192 °C.
- 4.5.3.12.1.2.4. The particulate sample shall be collected on a single filter mounted in a holder in the sampled diluted exhaust gas flow, per part of the WMTC cycle.
- 4.5.3.12.1.2.5. All parts of the dilution system and the sampling system from the exhaust pipe up to the filter holder which are in contact with raw and diluted exhaust gas shall be designed to minimize deposition or alteration of the particulates. All parts shall be made of electrically conductive materials that do not react with exhaust gas components, and shall be electrically grounded to prevent electrostatic effects.
- 4.5.3.12.1.2.6. If it is not possible to compensate for variations in the flow rate, provision shall be made for a heat exchanger and a temperature control device as specified in Appendix 4 so as to ensure that the flow rate in the system is constant and the sampling rate accordingly proportional.
- 4.5.3.12.1.3. **Specific requirements**
- 4.5.3.12.1.3.1. Particulate matter (PM) sampling probe
- 4.5.3.12.1.3.1.1 The sample probe shall deliver the particle-size classification performance described in clause 4.5.3.12.1.3.1.4 of this Chapter. It is recommended that this performance be achieved by the use of a sharp-edged, open-ended probe facing directly in the direction of flow, plus a pre-classifier (cyclone impactor etc.). An appropriate sampling probe, such as that indicated in Figure

7 of this Chapter, may alternatively be used provided it achieves the pre-classification performance described in clause 4.5.3.12.1.3.1.4 of this Chapter.

- 4.5.3.12.1.3.1.2. The sample probe shall be installed near the tunnel center line between 10 and 20 tunnel diameters downstream of the exhaust gas inlet to the tunnel and have an internal diameter of at least 12 mm.

If more than one simultaneous sample is drawn from a single sample probe, the flow drawn from that probe shall be split into identical sub-flows to avoid sampling artefacts.

If multiple probes are used, each probe shall be sharp-edged, open-ended and facing directly into the direction of flow. Probes shall be equally spaced at least 5 cm apart around the central longitudinal axis of the dilution tunnel.

- 4.5.3.12.1.3.1.3. The distance from the sampling tip to the filter mount shall be at least five probe diameters, but shall not exceed 1020 mm.

- 4.5.3.12.1.3.1.4. The pre-classifier (e.g. cyclone, impactor, etc.) shall be located upstream of the filter holder assembly. The pre-classifier 50 percent cut point particle diameter shall be between 2.5  $\mu\text{m}$  and 10  $\mu\text{m}$  at the volumetric flow rate selected for sampling particulate mass emissions. The pre-classifier shall allow at least 99 percent of the mass concentration of 1  $\mu\text{m}$  particles entering the pre-classifier to pass through the exit of the pre-classifier at the volumetric flow rate selected for sampling particulate mass emissions. However, a sampling probe, used as an appropriate size-classification device, such as that shown in Figure 7 of this Chapter, is acceptable as an alternative to a separate pre-classifier.

- 4.5.3.12.1.3.2. **Sample pump and flow meter**

- 4.5.3.12.1.3.2.1. The sample gas flow measurement unit shall consist of pumps, gas flow regulators and flow measuring units.

- 4.5.3.12.1.3.2.2. The temperature of the gas flow in the flow meter may not fluctuate by more than  $\pm 3^{\circ}\text{C}$ , except during regeneration tests on vehicles equipped with periodically regenerating after-treatment devices. In addition, the sample mass flow rate shall remain proportional to the total flow of diluted exhaust gas to within a tolerance of  $\pm 5$  percent of the particulate sample mass flow rate. Should the volume of flow change unacceptably as a result of excessive filter loading, the test shall be stopped. When the test is repeated, the rate of flow shall be decreased.

- 4.5.3.12.1.3.3. **Filter and filter holder**

- 4.5.3.12.1.3.3.1. A valve shall be located downstream of the filter in the direction of flow. The valve shall be responsive enough to open and close within one second of the start and end of the test.



- 4.5.3.12.1.3.3.2 It is recommended that the mass collected on the 47 mm diameter filter (Pe) is  $\geq 20 \mu\text{g}$  and that the filter loading is maximized in line with the requirements of clauses 4.5.3.12.1.2.3 and 4.5.3.12.1.3.3 of this Chapter.
- 4.5.3.12.1.3.3.3 For a given test, the gas filter face velocity shall be set to a single value within the range 20 cm/s to 80 cm/s, unless the dilution system is being operated with sampling flow proportional to CVS flow rate.
- 4.5.3.12.1.3.3.4 Fluorocarbon coated glass fibre filters or fluorocarbon membrane filters are required. All filter types shall have a  $0.3 \mu\text{m}$  DOP (di-octylphthalate) or PAO (poly-alpha-olefin) CS 68649-12-7 or CS 68037- 01-4 collection efficiency of at least 99 percent at a gas filter face velocity of 5.33 cm/s.
- 4.5.3.12.1.3.3.5 The filter holder assembly shall be of a design that provides an even flow distribution across the filter stain area. The filter stain area shall be at least  $1075 \text{ mm}^2$ .

4.5.3.12.1.3.4. **Filter weighing chamber and balance**

- 4.5.3.12.1.3.4.1. The microgram balance used to determine the weight of a filter shall have a precision (standard deviation) of  $2 \mu\text{g}$  and resolution of  $1 \mu\text{g}$  or better. It is recommended that the microbalance be checked at the start of each weighing session by weighing one reference weight of 50 mg. This weight shall be weighed three times and the average result recorded. The weighing session and balance are considered valid if the average result of the weighing is within  $\pm 5 \mu\text{g}$  of the result from the previous weighing session.

The weighing chamber (or room) shall meet the following conditions during all filter conditioning and weighing operations:

- Temperature maintained at  $295.2 \pm 3 \text{ K}$  ( $22 \pm 3^\circ\text{C}$ );
- Relative humidity maintained at  $45 \pm 8$  percent;
- Dew point maintained at  $282.7 \pm 3 \text{ K}$  ( $9.5 \pm 3^\circ\text{C}$ ).

It is recommended that temperature and humidity conditions be recorded along with sample and reference filter weights.

4.5.3.12.1.3.4.2. **Buoyancy correction**

All filter weights shall be corrected for filter buoyancy in air.

The buoyancy correction depends on the density of the sample filter medium, the density of air, and the density of the calibration weight used to calibrate the balance. The density of the air is dependent on the pressure, temperature and humidity.

It is recommended that the temperature and dew point of the weighing environment be controlled to  $22^\circ\text{C} \pm 1^\circ\text{C}$  and  $9.5 \pm 1^\circ\text{C}$  respectively.

However, the minimum requirements stated in clause 4.5.3.12.1.3.4.1. of this Chapter will also result in an acceptable correction for buoyancy effects.

The correction for buoyancy shall be applied as follows:  
Equation 1:

$$m_{\text{corr}} = m_{\text{uncorr}} * (1 - ((\rho_{\text{air}})/(\rho_{\text{weight}})))/(1 - ((\rho_{\text{air}})/(\rho_{\text{media}})))$$

where:

$m_{\text{corr}}$  = PM mass corrected for buoyancy

$m_{\text{uncorr}}$  = PM mass uncorrected for buoyancy

$\rho_{\text{air}}$  = density of air in balance environment

$\rho_{\text{weight}}$  = density of calibration weight used to span balance

$\rho_{\text{media}}$  = density of PM sample medium (filter) with filter medium Teflon coated glass fibre (e.g.TX40):  $\rho_{\text{media}} = 2.300 \text{ kg/m}^3$

$\rho_{\text{air}}$  can be calculated as follows:

Equation 2

$$\rho_{\text{air}} = \frac{P_{\text{abs}} \cdot M_{\text{mix}}}{R \cdot T_{\text{amb}}}$$

where:

$P_{\text{abs}}$  = absolute pressure in balance environment

$M_{\text{mix}}$  = molar mass of air in balance environment (28.836 gmol<sup>-1</sup>)

$R$  = molar gas constant (8.314 Jmol<sup>-1</sup>K<sup>-1</sup>)

$T_{\text{amb}}$  = absolute ambient temperature of balance environment

The chamber (or room) environment shall be free of any ambient contaminants (such as dust) that would settle on the particulate filters during their stabilization.

Limited deviations from weighing room temperature and humidity specifications shall be allowed provided their total duration does not exceed 30 minutes in any one filter conditioning period. The weighing room shall meet the required specifications prior to personal entrance into the weighing room. No deviations from the specified conditions are permitted during the weighing operation.

- 4.5.3.12.1.3.4.3. The effects of static electricity shall be nullified. This may be achieved by grounding the balance through placement on an antistatic mat and neutralization of the particulate filters prior to weighing using a Polonium neutralizer or a device of similar effect. Alternatively, nullification of static effects may be achieved through equalization of the static charge.

- 4.5.3.12.1.3.4.4. A test filter shall be removed from the chamber no earlier than an hour before the test begins.
- 4.5.3.12.1.4. Recommended system description Figure 3 of this Chapter, is a schematic drawing of the recommended particulate sampling system. Since various configurations can produce equivalent results, exact conformity with this Figure is not required. Additional components such as instruments, valves, solenoids, pumps and switches may be used to provide additional information and coordinate the functions of component systems. Further components that are not needed to maintain accuracy with other system configurations may be excluded if their exclusion is based on good engineering judgment.

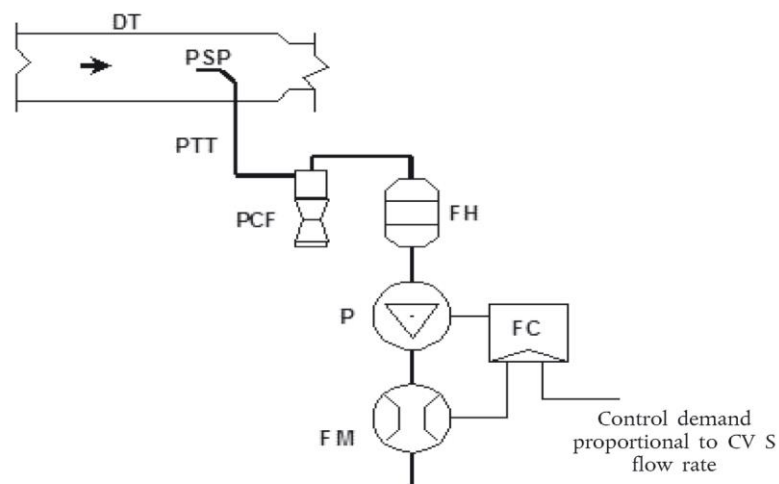

**Figure 3**

**Recommended particulate sampling system**

A sample of the diluted exhaust gas is taken from the full flow dilution tunnel (DT) through the particulate sampling probe (PSP) and the particulate transfer tube (PTT) by means of the pump (P). The sample is passed through the particle size pre-classifier (PCF) and the filter holders (FH) that contain the particulate sampling filters. The flow rate for sampling is set by the flow controller (FC)

4.5.4. **Driving schedules**

4.5.4.1. **Test cycles**

Test cycles (vehicle speed patterns) for the type I test consist of up to three parts, as laid down in Appendix 6 of chapter 2. The applicable part of WMTC for each sub-category shall be as per the notification.

4.5.4.2. **Vehicle speed tolerances**

4.5.4.2.1 The vehicle speed tolerance at any given time on the test cycles prescribed in clause 4.5.4.1. of this Chapter is defined by upper and lower limits. The upper limit is 3.2 km/h higher than the highest point on the trace within one second of the given time. The lower limit is 3.2 km/h lower than the lowest point on the trace within one second of the given time. Vehicle speed variations greater than the tolerances (such as may occur during gear changes) are acceptable provided they occur for less than two seconds on any occasion. Vehicle speeds lower than those prescribed are acceptable provided the vehicle is operated at maximum available power during such occurrences. Figure 4 of this Chapter shows the range of acceptable vehicle speed tolerances for typical points.

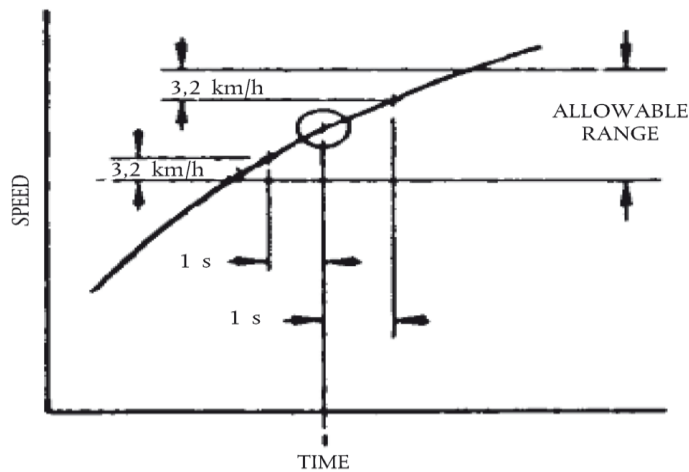

**Figure 4**

**Rider Trace Allowable range**

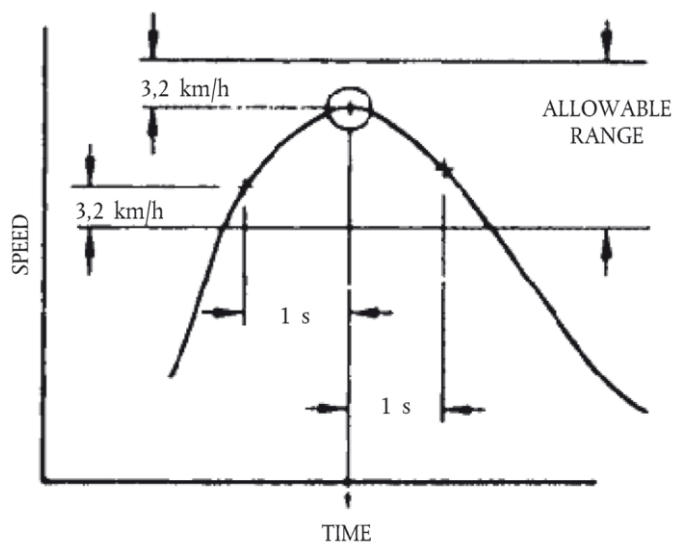

**Figure 5**

**Rider Trace Allowable range**

- 4.5.4.2.2. If the acceleration capability of the vehicle is not sufficient to carry out the acceleration phases or if the maximum design speed of the vehicle is lower than the prescribed cruising speed within the prescribed limits of tolerances, the vehicle shall be driven with the throttle fully open until the set speed is reached or at the maximum design speed achievable with fully opened throttle during the time that the set speed exceeds the maximum design speed. In both cases, clause 4.5.4.2.1 of this Chapter is not applicable. The test cycle shall be carried on normally when the set speed is again lower than the maximum design speed of the vehicle.
- 4.5.4.2.3. If the period of deceleration is shorter than that prescribed for the corresponding phase, the set speed shall be restored by a constant vehicle speed or idling period merging into succeeding constant speed or idling operation. In such cases, clause 4.5.4.2.1 of this chapter is not applicable.
- 4.5.4.2.4. Apart from these exceptions, the deviations of the roller speed from the set speed of the cycles shall meet the requirements described in clause 4.5.4.2.1 of this Chapter. If not, the test results shall not be used for further analysis and the run shall be repeated.
- 4.5.5. **Gearshift prescriptions for the WMTC prescribed in Appendix 6 of this Chapter**
- 4.5.5.1. **Test vehicles with automatic transmission**
- 4.5.5.1.1. Vehicles equipped with transfer cases, multiple sprockets, etc., shall be tested in the configuration recommended by the manufacturer for street or highway use.
- 4.5.5.1.2. All tests shall be conducted with automatic transmissions in 'Drive' (highest gear). Automatic clutch- torque converter transmissions may be shifted as manual transmissions at the request of the manufacturer.
- 4.5.5.1.3. Idle modes shall be run with automatic transmissions in 'Drive' and the wheels braked.
- 4.5.5.1.4. Automatic transmissions shall shift automatically through the normal sequence of gears. The torque converter clutch, if applicable, shall operate as under real-world conditions.
- 4.5.5.1.5. The deceleration modes shall be run in gear using brakes or throttle as necessary to maintain the desired speed.
- 4.5.5.2. **Test vehicles with manual transmission**
- 4.5.5.2.1 **Mandatory requirements**
- 4.5.5.2.1.1. Step 1 — Calculation of shift speeds
- Upshift speeds ( $V_{1 \rightarrow 2}$  and  $V_{i \rightarrow i+1}$ ) in km/h during acceleration phases shall be calculated using the following formulae.

Equation 3

$$V_{i \rightarrow i+1} = \left[ \left( 0.5753 * e^{\left( -1.9 * \frac{P_n}{m_{ref}} \right)} * (s - n_{idle}) + n_{idle} \right) * \frac{1}{ndv_i} \right]$$

i=2 to ng-1

Equation 4

$$V_{1 \rightarrow 2} = \left[ \left( 0.5753 * e^{\left( -1.9 * \frac{P_n}{m_{ref}} \right)} - 0.1 \right) * (s - n_{idle}) + n_{idle} \right] * \frac{1}{ndv_1}$$

where:

‘i’ is the gear number ( $\geq 2$ )

‘ng’ is the total number of forward gears

‘P<sub>n</sub>’ is the rated power in kW

‘m<sub>ref</sub>’ is the reference mass in kg

‘n<sub>idle</sub>’ is the idling speed in min<sup>-1</sup>

‘s’ is the rated engine speed in min<sup>-1</sup>

‘ndv<sub>i</sub>’ is the ratio between engine speed in min-1 and vehicle speed in km/h in gear ‘i’

4.5.5.2.1.2.

Downshift speeds ( $V_{i \rightarrow i-1}$ ) in km/h during cruise or deceleration phases in gears 4 (4th gear) to ng shall be calculated using the following formula:

Equation 5

$$V_{i \rightarrow i-1} = \left[ \left( 0.5753 * e^{\left( -1.9 * \frac{P_n}{m_{ref}} \right)} * (s - n_{idle}) + n_{idle} \right) * \frac{1}{ndv_{i-2}} \right],$$

i= 4 to ng

where:

‘i’ is the gear number ( $\geq 4$ )

‘ng’ is the total number of forward gears

‘P<sub>n</sub>’ is the rated power in kW

‘m<sub>ref</sub>’ is the reference mass in kg.

‘n<sub>idle</sub>’ is the idling speed in min<sup>-1</sup>

‘s’ is the rated engine speed in min<sup>-1</sup>

‘ndv<sub>i-2</sub>’ is the ratio between engine speed in min<sup>-1</sup> and vehicle speed in km/h in gear i-2

The downshift speed from gear 3 to gear 2 ( $V_{3 \rightarrow 2}$ ) shall be calculated using the following equation:

Equation 6

$$V_{3 \rightarrow 2} = \left[ \left( 0.5753 * e^{\left( -1.9 * \frac{P_n}{m_{ref}} \right)} - 0.1 \right) * (s - n_{idle}) + n_{idle} \right] * \frac{1}{ndv_1}$$

where:

$P_n$  is the rated power in kW

' $m_{ref}$ ' is the reference mass in kg.

' $n_{idle}$ ' is the idling speed in  $\text{min}^{-1}$

$s$  is the rated engine speed in  $\text{min}^{-1}$

$ndv_1$  is the ratio between engine speed in  $\text{min}^{-1}$  and vehicle speed in km/h in gear 1

The downshift speed from gear 2 to gear 1 ( $V_{2 \rightarrow 1}$ ) shall be calculated using the following equation

Equation 7:

$$V_{2 \rightarrow 1} = [0.03 * (s - n_{idle}) + n_{idle}] * \frac{1}{ndv_2}$$

where:

$ndv_2$  is the ratio between engine speed in  $\text{min}^{-1}$  and vehicle speed in km/h in gear 2

Since the cruise phases are defined by the phase indicator, slight speed increases could occur and it may be appropriate to apply an upshift. The upshift speeds ( $V_{1 \rightarrow 2}$ ,  $V_{2 \rightarrow 3}$  and  $V_{i \rightarrow i+1}$ ) in km/h during cruise phases shall be calculated using the following equations

Equation 7a:

$$V_{1 \rightarrow 2} = [0.03 * (s - n_{idle}) + n_{idle}] * \frac{1}{ndv_2}$$

Equation 8:

$$V_{2 \rightarrow 3} = \left[ \left( 0.5753 * e^{\left( -1.9 * \frac{P_n}{m_{ref}} \right)} - 0.1 \right) * (s - n_{idle}) + n_{idle} \right] * \frac{1}{ndv_1}$$

Equation 9

$$V_{i \rightarrow i+1} = \left[ \left( 0.5753 * e^{\left( -1.9 * \frac{P_n}{m_{ref}} \right)} \right) * (s - n_{idle}) + n_{idle} \right] * \frac{1}{ndv_{i-1}},$$

$i=3$  to  $ng$

#### 4.5.5.2.1.3.

### Step 2 — Gear choice for each cycle sample

In order to avoid different interpretations of acceleration, deceleration, cruise and stop phases, corresponding indicators are added to the vehicle speed pattern as integral parts of the cycles (see tables in Appendix 6).

The appropriate gear for each sample shall then be calculated according to the vehicle speed ranges resulting from the shift speed equations of clause 4.5.5.2.1.1 of this Chapter and the phase indicators for the cycle parts appropriate for the test vehicle, as follows:

**Gear choice for stop phases:**

For the last five seconds of a stop phase, the gear lever shall be set to gear 1 and the clutch shall be disengaged. For the previous part of a stop phase, the gear lever shall be set to neutral or the clutch shall be disengaged.

**Gear choice for acceleration phases:**

- gear 1, if  $v \leq v_{1 \rightarrow 2}$
- gear 2, if  $v_{1 \rightarrow 2} < v \leq v_{2 \rightarrow 3}$
- gear 3, if  $v_{2 \rightarrow 3} < v \leq v_{3 \rightarrow 4}$
- gear 4, if  $v_{3 \rightarrow 4} < v \leq v_{4 \rightarrow 5}$
- gear 5, if  $v_{4 \rightarrow 5} < v \leq v_{5 \rightarrow 6}$
- gear 6, if  $v > v_{5 \rightarrow 6}$

**Gear choice for deceleration or cruise phases:**

- gear 1, if  $v < v_{2 \rightarrow 1}$
- gear 2, if  $v < v_{3 \rightarrow 2}$
- gear 3, if  $v_{3 \rightarrow 2} \leq v < v_{4 \rightarrow 3}$
- gear 4, if  $v_{4 \rightarrow 3} \leq v < v_{5 \rightarrow 4}$
- gear 5, if  $v_{5 \rightarrow 4} \leq v < v_{6 \rightarrow 5}$
- gear 6, if  $v \geq v_{4 \rightarrow 5}$

The clutch shall be disengaged, if:

the vehicle speed drops below 10 km/h, or

the engine speed drops below  $n_{idle} + 0.03 * (s - n_{idle})$ ;

There is a risk of engine stalling during cold-start phase.

4.5.5.2.2 **Step 3 — Corrections according to additional requirement**

4.5.5.2.2.1 The gear choice shall be modified according to the following requirements:

- a) no gearshift at a transition from an acceleration phase to a deceleration phase. The gear that was used for the last second of the acceleration phase shall be kept for the following deceleration phase unless the speed drops below a downshift speed;
- b) no upshifts or downshifts by more than one gear, except from gear 2 to neutral during decelerations down to stop;



c) upshifts or downshifts for up to four seconds are replaced by the gear before, if the gears before and after are identical, e.g. 2 3 3 3 2 shall be replaced by 2 2 2 2 2, and 4 3 3 3 3 4 shall be replaced by 4 4 4 4 4 4. In the cases of consecutive circumstances, the gear used longer takes over, e.g. 2 2 2 3 3 3 2 2 2 3 3 3 will be replaced by 2 2 2 2 2 2 2 2 2 3 3 3. If used for the same time, a series of succeeding gears shall take precedence over a series of preceding gears, e.g. 2 2 2 3 3 3 2 2 3 3 3 will be replaced by 2 2 2 2 2 2 2 2 2 3 3 3;

d) no downshift during an acceleration phase.

4.5.5.2.3

**Optional provisions**

The gear choice may be modified according to the following provisions:

The use of gears lower than those determined by the requirements described in clause 4.5.5.2.1 of this Chapter is permitted in any cycle phase. Manufacturers' recommendations for gear use shall be followed if they do not result in gears higher than determined by the requirements of clause 4.5.5.2.1 of this Chapter.

4.5.5.2.4

Explanations of the approach and the gearshift strategy and a calculation example are given in Appendix 8 of this Chapter.

<http://www.unece.org/trans/main/wp29/wp29wgs/wp29grpe/wmtc.html>

4.5.6.

**Dynamometer settings**

A full description of the chassis dynamometer and instruments shall be provided in accordance with Appendix 3. Measurements shall be taken to the accuracies specified in clause 4.5.7 of this chapter. The running resistance force for the chassis dynamometer settings can be derived either from on-road coast-down measurements or from a running resistance table given in Appendix 5 or 7 of this Chapter for a vehicle equipped with one wheel on the powered axle.

4.5.6.1.

Chassis dynamometer setting derived from on-road coast-down measurements

To use this alternative, on-road coast-down measurements shall be carried out as specified in Appendix 7 for the vehicle equipped with one wheel on the power axle.

4.5.6.1.1.

**Requirements for the equipment**

The instrumentation for the speed and time measurement shall have the accuracies specified in clause 4.5.7 of this Chapter.

4.5.6.1.2. **Inertia mass setting**

4.5.6.1.2.1. The equivalent inertia mass  $m_i$  for the chassis dynamometer shall be the flywheel equivalent inertia mass,  $m_{fi}$ , closest to the sum of the mass in running order of the vehicle and the mass of the Rider (75 kg). Alternatively, the equivalent inertia mass  $m_i$  can be derived from Appendix 5.

4.5.6.1.2.2. If the reference mass  $m_{ref}$  cannot be equalized to the flywheel equivalent inertia mass  $m_i$ , to make the target running resistance force  $F^*$  equal to the running resistance force  $F_E$  (which is to be set to the chassis dynamometer), the corrected coast-down time  $\Delta T_E$  may be adjusted in accordance with the total mass ratio of the target coast-down time  $\Delta T_{road}$  in the following sequence:

Equation 10

$$\Delta T_{road} = \frac{1}{3.6} (m_a + m_{r1}) \frac{2\Delta V}{F^*}$$

Equation 11

$$\Delta T_E = \frac{1}{3.6} (m_i + m_{r1}) \frac{2\Delta V}{F_E}$$

Equation 12

$$F_E = F^*$$

Equation 13

$$\Delta T_E = \Delta T_{road} * \frac{m_i + m_{r1}}{m_a + m_{r1}}$$

With  $0.95 < \frac{m_i + m_{r1}}{m_a + m_{r1}} < 1.05$

where

$m_{r1}$  may be measured or calculated, in kilograms, as appropriate. As an alternative,  $m_{r1}$  may be estimated as 4 percent of  $m$ .

4.5.6.2. Running resistance force derived from a running resistance table

4.5.6.2.1. The chassis dynamometer may be set by the use of the running resistance table instead of the running resistance force obtained by the coast-down method. In this table method, the chassis dynamometer shall be set by the reference mass regardless of particular vehicle characteristics.

**Note:** Care shall be taken when applying this method to vehicles with extraordinary characteristics.

4.5.6.2.2. The flywheel equivalent inertia mass  $m_{fi}$  shall be the equivalent inertia mass  $m_i$  specified in Appendix 5 or 7 where applicable. The chassis dynamometer shall be set by the rolling resistance of the non-driven wheels and the aero drag coefficient ( $b$ ) specified in Appendix 5 or determined in accordance with the procedures set out in Appendix 7.

4.5.6.2.3. The running resistance force on the chassis dynamometer  $F_E$  shall be determined using the following equation:

Equation 14

$$F_E = F_T = a + b * V^2$$

4.5.6.2.4. The target running resistance force  $F^*$  shall be equal to the running resistance force obtained from the running resistance table  $F_T$ , because the correction for the standard ambient conditions is not necessary.

4.5.7. Measurement accuracies:

Measurements shall be taken using equipment that full fills the accuracy requirements in Table 1 of this chapter.

**Table 1**  
**Required accuracy of measurements**

Measurement items	At measured value	Resolution
(a) Running resistance force, F	+ 2 percent	—
(b) Vehicle speed ( $v_1, v_2$ )	$\pm 1$ percent	0.2 km/h
(c) Coast-down speed interval ( $2\Delta v = v_1 - v_2$ )	$\pm 1$ percent	0.1 km/h
(d) Coast-down time ( $\Delta t$ )	$\pm 0.5$ percent	0.01 s
(e) Total vehicle mass ( $m_{ref} + m_{rid}$ )	$\pm 0.5$ percent	1.0 kg
(f) Wind speed	$\pm 10$ percent	0.1 m/s
(g) Wind direction	—	5 deg.
(h) Temperatures	$\pm 1$ K	1 K
(i) Barometric pressure	—	0.2 kPa
(j) Distance	$\pm 0.1$ percent	1 m
(k) Time	$\pm 0.1$ s	0.1 s

**5.0 TEST PROCEDURES**

**5.1. Description of the Type I test**

The test vehicle shall be subjected, according to its category, to test Type I requirements as specified in the following sub-clauses.

5.1.1 Type I test (verifying the average emission of gaseous pollutants, CO<sub>2</sub> emissions and fuel consumption in a characteristic driving cycle).

5.1.1.1. The test shall be carried out by the method described in clause 5.2 of this chapter. The gases shall be collected and analyzed by the prescribed methods.

5.1.1.2. Number of tests

5.1.1.2.1.

The number of tests shall be determined as shown in Figure 6 of this Chapter.  $R_{i1}$  to  $R_{i3}$  describe the final measurement results for the first (No 1) test to the third (No 3) test and the gaseous pollutants. Nevertheless, for each of the pollutants one of the three results obtained may exceed by not more than 10 percent of the applicable limits prescribed for the vehicle concerned, provided the arithmetical mean of the three results is not exceeding the prescribed limit. Where the prescribed limits are exceeded for more than one pollutant, it shall be immaterial whether this occurs in the same test or in different tests

The final result for CO<sub>2</sub> and fuel consumption shall be the average of results from the number of tests carried out in the case of  $R_{i2}$  and  $R_{i3}$ .

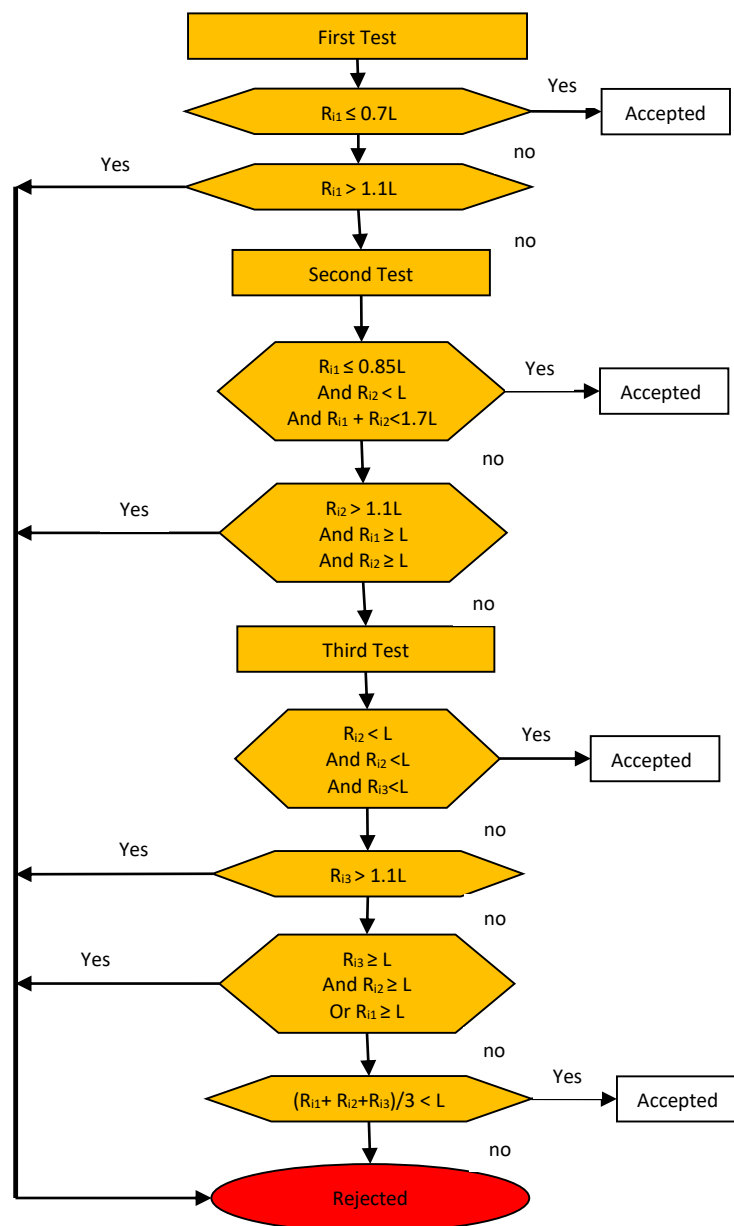

**Figure 6**  
Flow chart for the number of Type I tests.

5.1.1.2.1.1 The number of tests prescribed in Clause 5.1.1.2.2 of this chapter above shall be reduced in the conditions hereinafter defined, where  $R_{i1}$  is the result of the first test and  $R_{i2}$  is the result of the second test for each of the pollutants referred to in Clause 5.1.1.1 above.

5.1.1.2.1.2 Only one test shall be performed if the result obtained for each pollutant is less than or equal to 0.7 L (i.e.  $R_{i1} \leq 0.70$  L).

5.1.1.2.1.3 If the requirements of 5.1.1.2.3.1 is not satisfied, only two tests are performed if for each pollutant in case of the limit is so specified, the following requirements are met.

$$R_{i1} \leq 0.85 \text{ L and } R_{i1} + R_{i2} \leq 1.70 \text{ L and } R_{i2} < L.$$

Subject to the provisions of the clause 5.1.1.2.2 & 5.1.1.2.3, of this Chapter the test shall be repeated three times, the test results shall be multiplied by appropriate deterioration factors as notified in CMVR/notification.

$$(R_{i1} + R_{i2} + R_{i3})/3 < L.$$

The resulting masses of gaseous emission and, in the case of vehicles equipped with compression-ignition engines, the mass of particulates obtained in each test shall not exceed the applicable limits.

5.1.1.2.2. In each test, the masses of the carbon monoxide, hydrocarbons, nitrogen oxides, carbon dioxide and the fuel consumed during the test shall be determined. The mass of particulate matter shall be determined only for vehicles fitted with direct injection PI engines and CI engines.

5.1.1.2.3 Manufacturers shall ensure that type-approval requirements for verifying durability requirements for CO, HC, NO<sub>x</sub>, NMHC and if applicable PM are met. At the choice of the manufacturer, one of the following durability test procedures shall be used to provide evidence to the test agency that the environmental performance of a type-approved parent vehicle is durable.

The final results shall be rounded off to nearest (mg) as per IS: 2 as amended from time to time.

5.1.1.2.3.1 Fixed DF (Mathematical Durability Procedure)

For each emission constituent, the product of the deterioration factor set out in notification and the environmental test result of Type I test shall be lower than the emission limits set out in notification.

5.1.1.2.3.2 Actual Durability Test with Full Mileage Accumulation

The test vehicles shall physically accumulate the full distance set out in notification and shall be tested in accordance with the procedure laid down in test type V. The emission test results up to and including the full distance shall be lower than the emission limits set out in notification.

- 5.1.1.2.3.3 Actual Durability Test with Partial Mileage Accumulation:
- The test vehicles shall physically accumulate a minimum of 50 % of the full distance set out in notification and shall be tested in accordance with the procedure laid down in test type V. As specified in the procedure, the test results shall be extrapolated up to the full distance set out in notification. Both the test results and the extrapolated results shall be lower than the emission limits set out in notification.
- 5.1.1.2.3.4 DF requirements for Type Approval of New Variant/Vehicle of same family of Type V test:
- The test shall be carried out on a run-in vehicle. At the choice of the manufacturer, one of the following durability test procedures shall be used to provide evidence to the test agency that the environmental performance of a type-approved family vehicle is durable.
- 5.1.1.2.3.4.1 Fixed DF (Mathematical Durability Procedure) :
- For each emission constituent, the product of the deterioration factor set out in notification and the environmental test result of Type I test shall be lower than the emission limits set out in notification.
- 5.1.1.2.3.4.2 Actual Durability Test with Full Mileage Accumulation done for parent vehicle:
- In case the manufacturer has followed durability test procedure as per Clause 5.1.1.2.3.2 of this chapter for parent vehicle, then:
- (a) The exhaust emission values with applying multiplicative or additive DF value calculated as per Clause 3.2.4.6 of Chapter 5 and the environmental test result of Type I test shall be lower than the emission limits set out in notification; or
- (b) If fully aged Golden component shall be used, then environmental test result of Type I test shall be lower than the emission limits set out in notification. Deterioration factor to be calculated as per Clause 3.2.4.6 of Chapter 5.
- 5.1.1.2.3.4.3 Actual Durability Test with Partial Mileage Accumulation done for parent vehicle:
- In case the manufacturer has followed durability test procedure as per Clause 5.1.1.2.3.3 of this chapter for parent vehicle, then:
- (a) The exhaust emission values with applying multiplicative or additive DF value calculated Clause as per 3.2.4.7 of Chapter 5 and the result of Type I test shall be lower than the emission limits set out in notification; or

- (b) If partially aged Golden component shall be used, then the exhaust emission values with applying multiplicative or additive DF for remaining portion of durability distance shall be calculated as per Clause 3.2.4.8 of Chapter 5 and environmental test result of Type I test shall be lower than the emission limits set out in notification.
- (c) Using the Emission results of Parent vehicle and the emission result of test vehicle (fitted with partial aged golden pollution control devices) at partial mileage, the test results shall be extrapolated up to the full distance set out in the notification. Both the test results and the extrapolated results shall be lower than the emission limits set out in the notification.

5.1.1.2.3.5

DF requirements for COP test shall be as follows:

DF for COP of a variant/parent model shall be the DF being used for type approval of the variant/parent model. If the type approval test has been done by actual mileage accumulation, then applicable DF referred in 5.1.1.2.3.4.2 (a) and 5.1.1.2.3.4.3 (a), (b) of this chapter shall be used.

For 5.1.1.2.3.4.2 (b) of this chapter, DF for COP shall be the DF calculated as per clause 3.2.4.6 of Chapter 5.

For 5.1.1.2.3.4.3 (c) of this chapter, DF for COP shall be the DF calculated as per clause 3.2.4.7 of Chapter 5 using Parent vehicle results.

For each emission constituent, the product of the deterioration factor and the environmental test result of Type I test shall be lower than the emission limits set out in the notification.

5.1.1.2.4

At the choice of the manufacturer one of the following durability test procedures as described in below table of this chapter shall be used for type approval.

The emission test results Calculated by applicable D.F shall be lower than emission limits set out in the notification.

If the actual mileage accumulation (full or partial) has been carried out, none of the emission values shall exceed these limits.

Table 2					
Option No.	Option		D.F to be applied		Relative Clause
	Condition of Vehicle for Type-I test.	Condition of Pollution control devices	Applicable D.F. for Type Approval	D.F. Calculation	
1	New vehicle, run-in	Degreened by Running-In	Fixed D.F	As per the Notification	5.1.1.2.3.1, 5.1.1.2.3.4.1
2 <sup>(1)</sup>	Aged	Full mileage Accumulation done as per Chapter 5	No D.F to be applied	3.2.4.6 of Chapter 5 [Only calculation]	5.1.1.2.3.2
3 <sup>(1)</sup>	Partially aged	Partial Mileage accumulation done as per Chapter 5	No D.F to be applied	(i) 3.2.4.7 and (ii) 3.2.4.8 of Chapter 5 [Only calculation]	5.1.1.2.3.3
4	New vehicle, run-in	Degreened by Running-In	D.F. Calculated in Option 2	--	5.1.1.2.3.4.2 (a)
			D.F. Calculated in Option 3 (i)	--	5.1.1.2.3.4.3 (a)
5	New vehicle, run-in	Using fully aged golden pollution control devices	No D.F to be applied	3.2.4.6 of Chapter 6 [Only calculation]	5.1.1.2.3.4.2 (b)
6	New Vehicle, run-in	Using partially aged golden pollution control devices	D.F. calculated in Option No. 3 (ii). of table	--	5.1.1.2.3.4.3 (b)
			No D.F to be applied	--	5.1.1.2.3.4.3 (c)

<sup>(1)</sup> Test vehicle is the parent vehicle for options 4, 5 and 6.



**5.2. Type I tests****5.2.1. Overview**

5.2.1.1. The type I test consists of prescribed sequences of dynamometer preparation, fuelling, Parking, and operating conditions.

5.2.1.2. The test is designed to determine hydrocarbon, carbon monoxide, oxides of nitrogen, carbon dioxide, particulate matter mass emissions if applicable and fuel / energy consumption as well as electric range while simulating real-world operation. The test consists of engine start-ups and L2-category vehicle operation on a chassis dynamometer, through a specified driving cycle. A proportional part of the diluted exhaust emissions is collected continuously for subsequent analysis, using a constant volume (variable dilution) sampler (CVS).

5.2.1.3. Except in cases of component malfunction or failure, all emission-control systems installed on or incorporated in a tested L2-category vehicle shall be functioning during all Procedures.

5.2.1.4. Background concentrations are measured for all emission constituents for which emissions measurements are taken. For exhaust testing, this requires sampling and analysis of the dilution air.

5.2.1.5. Background particulate mass measurement

The particulate background level of the dilution air may be determined by passing filtered dilution air through the particulate filter. One measurement may be performed prior to or after the test. Particulate mass measurements may be corrected by subtracting the background contribution from the dilution system. The permissible background contribution shall be  $\leq 1$  mg/km (or equivalent mass on the filter). If the background contribution exceeds this level, the default Figure 1 of this Chapter mg/km (or equivalent mass on the filter) shall be used. Where subtraction of the background contribution gives a negative result, the particulate mass result shall be considered to be zero.

**5.2.2. Dynamometer settings and verification**

5.2.2.1 Test vehicle preparation

5.2.2.1.1 The manufacturer shall provide additional fittings and adapters, as required to accommodate a fuel drain at the lowest point possible in the tanks as installed on the vehicle, and to provide for exhaust sample collection.

5.2.2.1.2 The tyre pressures shall be adjusted to the manufacturer's specifications to the satisfaction of the technical service or so that the speed of the vehicle during the road test and the vehicle speed obtained on the chassis dynamometer are equal.

- 5.2.2.1.3 The test vehicle shall be warmed up on the chassis dynamometer to the same condition as it was during the road test.
- 5.2.2.2. Dynamometer preparation, if settings are derived from on-road coast-down measurements

Before the test, the chassis dynamometer shall be appropriately warmed up to the stabilized frictional force  $F_f$ . The load on the chassis dynamometer  $F_E$  is, in view of its construction, composed of the total friction loss  $F_f$ , which is the sum of the chassis dynamometer rotating frictional resistance, the tyre rolling resistance, the frictional resistance of the rotating parts in the powertrain of the vehicle and the braking force of the power absorbing unit (pau)  $F_{pau}$ , as in the following equation:

Equation 15:

$$F_E = F_f + F_{pau}$$

The target running resistance force  $F^*$  derived from Appendix 5 or 7 for a vehicle equipped with one wheel on the powered axle shall be reproduced on the chassis dynamometer in accordance with the vehicle speed, i.e.

Equation 16:

$$F_E(v_i) = F^*(v_i)$$

The total friction loss  $F_f$  on the chassis dynamometer shall be measured by the method in clause 5.2.2.2.1 or 5.2.2.2.2 of this chapter.

- 5.2.2.2.1. Motoring by chassis dynamometer

This method applies only to chassis dynamometers capable of driving vehicle. The test vehicle shall be driven steadily by the chassis dynamometer at the reference speed  $v_0$  with the drive train engaged and the clutch disengaged. The total friction loss  $F_f(v_0)$  at the reference speed  $v_0$  is given by the chassis dynamometer force.

- 5.2.2.2.2. Coast-down without absorption

The method for measuring the coast-down time is the coast-down method for the measurement of the total friction loss  $F_f$ . The vehicle coast-down shall be performed on the chassis dynamometer by the procedure described in Appendix 5 or 7 for a vehicle equipped with one wheel on the powered axle with zero chassis dynamometer absorption. The coast-down time  $\Delta t_i$  corresponding to the reference speed  $v_0$  shall be measured. The measurement shall be carried out at least three times, and the mean coast-down time  $\Delta t$  shall be calculated using the following equation:

Equation 17

$$\bar{\Delta t} = \frac{1}{n} \sum_{i=1}^n \Delta t_i$$

5.2.2.2.3. Total friction loss

The total friction loss  $F_{f(v_0)}$  at the reference speed  $v_0$  is calculated using the following equation:

Equation 18

$$F_f(v_0) = \frac{1}{3.6} (m_i + m_{r1}) \frac{2\Delta v}{\Delta t}$$

5.2.2.2.4. Calculation of power-absorption unit force

The force  $F_{pau}(v_0)$  to be absorbed by the chassis dynamometer at the reference speed  $v_0$  is calculated by subtracting  $F_f(v_0)$  from the target running resistance force  $F^*(v_0)$  as shown in the following equation:

Equation 19

$$F_{pau}(v_0) = F^*(v_0) - F_f(v_0)$$

5.2.2.2.5. Chassis dynamometer setting

Depending on its type, the chassis dynamometer shall be set by one of the methods described in clauses 5.2.2.2.5.1 to 5.2.2.2.5.4 of this Chapter. The chosen setting shall be applied to the pollutant and CO<sub>2</sub> emission measurements.

5.2.2.2.5.1. Chassis dynamometer with polygonal function

In the case of a chassis dynamometer with polygonal function, in which the absorption characteristics are determined by load values at several speed points, at least three specified speeds, including the reference speed, shall be chosen as the setting points. At each setting point, the chassis dynamometer shall be set to the value  $F_{pau}(v_j)$  obtained in clause 5.2.2.2.4 of this Chapter.

5.2.2.2.5.2. Chassis dynamometer with coefficient control

In the case of a chassis dynamometer with coefficient control, in which the absorption characteristics are determined by given coefficients of a polynomial function, the value of  $F_{pau}(v_j)$  at each specified speed shall be calculated by the procedure in clause 5.2.2.2 of this Chapter.

Assuming the load characteristics to be:

Equation 20

$$F_{pau}(v) = a * v^2 + b * v + c$$

where:

the coefficients a, b and c shall be determined by the polynomial regression method.

The chassis dynamometer shall be set to the coefficients a, b and c obtained by the polynomial regression method.

5.2.2.2.5.3. Chassis dynamometer with  $F^*$  polygonal digital setter

In the case of a chassis dynamometer with a polygonal digital setter, where a central processor unit is incorporated in the system,  $F^*$  is input directly, and  $\Delta t_i$ ,  $F_f$  and  $F_{pau}$  are automatically measured and calculated to set the chassis dynamometer to the target running resistance force:

Equation 21

$$F^* = f_0 + f_2 * v^2$$

In this case, several points in succession are directly input digitally from the data set of  $F^*$  and  $v$ , the coast-down is performed and the coast-down time  $\Delta t_i$  is measured. After the coast-down test has been repeated several times,  $F_{pau}$  is automatically calculated and set vehicle speed intervals of 0.1 km/h, in the following sequence:

Equation 22

$$F^* + F_f = \frac{1}{3.6} (m_i + m_{r1}) \frac{2\Delta v}{\Delta t_i}$$

Equation 23

$$F_f = \frac{1}{3.6} (m_i + m_{r1}) \frac{2\Delta v}{\Delta t_i} - F^*$$

Equation 24

$$F_{pau} = F^* - F_f$$

5.2.2.2.5.4. Chassis dynamometer with  $f^*_0$ ,  $f^*_2$  coefficient digital setter

In the case of a chassis dynamometer with a coefficient digital setter, where a central processor unit is incorporated in the system, the target running resistance force  $F^* = f_0 + f_2 * v^2$  is automatically set on the chassis dynamometer.

In this case, the coefficients  $f^*_0$  and  $f^*_2$  are directly input digitally; the coast-down is performed and the coast-down time  $\Delta t_i$  is measured.  $F_{pau}$  is automatically calculated and set at vehicle speed intervals of 0.06 km/h, in the following sequence:

Equation 25

$$F^* + F_f = \frac{1}{3.6} (m_i + m_{r1}) \frac{2\Delta v}{\Delta t_i}$$

Equation 26

$$F_f = \frac{1}{3.6}(m_i + m_{r1}) \frac{2\Delta v}{\Delta t_i} - F^*$$

Equation 27

$$F_{pau} = F^* - F_f$$

5.2.2.2.6. Dynamometer settings verification

5.2.2.2.6.1. Verification test

Immediately after the initial setting, the coast-down time  $\Delta t_E$  on the chassis dynamometer corresponding to the reference speed ( $v_0$ ) shall be measured by the procedure set out in Appendix 5 or 7 of this Chapter for a vehicle equipped with one wheel on the powered axle. The measurement shall be carried out at least three times, and the mean coast-down time  $\Delta t_E$  shall be calculated from the results.

The set running resistance force at the reference speed,  $F_E(v_0)$  on the chassis dynamometer is calculated by the following equation:

Equation 28

$$F_E(v_0) = \frac{1}{3.6}(m_i + m_{r1}) \frac{2\Delta v}{\Delta t_E}$$

5.2.2.2.6.2. Calculation of setting error

The setting error  $\varepsilon$  is calculated by the following equation

Equation 29

$$\varepsilon = \frac{|F_E(v_0) - F^*(v_0)|}{F^*(v_0)} \times 100$$

The chassis dynamometer shall be readjusted if the setting error does not satisfy the following criteria:

$$\varepsilon \leq 2 \text{ percent for } v_0 \geq 50 \text{ km/h}$$

$$\varepsilon \leq 3 \text{ percent for } 30 \text{ km/h} \leq v_0 < 50 \text{ km/h}$$

$$\varepsilon \leq 10 \text{ percent for } v_0 < 30 \text{ km/h}$$

The procedure in clauses 5.2.2.2.6.1 to 5.2.2.2.6.2 of this chapter shall be repeated until the setting error satisfies the criteria. The chassis dynamometer setting and the observed errors shall be recorded.

5.2.2.3. Dynamometer preparation, if settings are derived from a running resistance table

5.2.2.3.1. The specified vehicle speed for the chassis dynamometer

The running resistance on the chassis dynamometer shall be verified at the specified vehicle speed  $v$ . At least four specified speeds shall be verified. The range of specified vehicle speed points (the interval between the maximum and minimum points) shall extend either side of the reference speed or the reference speed range, if there is more than one reference speed, by at least  $\Delta v$ , as defined in Appendix 5 or 7 for a vehicle equipped with one wheel on the powered axle. The specified speed points, including the reference speed points, shall be at regular intervals of not more than 20 km/h apart.

#### 5.2.2.3.2. Verification of chassis dynamometer

5.2.2.3.2.1 Immediately after the initial setting, the coast-down time on the chassis dynamometer corresponding to the specified speed shall be measured. The vehicle shall not be set up on the chassis dynamometer during the coast-down time measurement. The coast-down time measurement shall start when the chassis dynamometer speed exceeds the maximum speed of the test cycle.

5.2.2.3.2.2 The measurement shall be carried out at least three times, and the mean coast-down time  $\Delta t_E$  shall be calculated from the results.

5.2.2.3.2.3. The set running resistance force  $F_E(v_j)$  at the specified speed on the chassis dynamometer is calculated using the following equation.

Equation 30

$$F_E(v_j) = \frac{1}{3.6} * m_i * \frac{2\Delta v}{\Delta t_E}$$

5.2.2.3.2.4. The setting error  $\varepsilon$  at the specified speed is calculated using the following equation.

Equation 31

$$\varepsilon = \frac{|F_E(v_j) - F_T|}{F_T} \times 100$$

5.2.2.3.2.5. The chassis dynamometer shall be readjusted if the setting error does not satisfy the following criteria:

$\varepsilon \leq 2$  percent for  $v \geq 50$  km/h

$\varepsilon \leq 3$  percent for  $30 \text{ km/h} \leq v < 50 \text{ km/h}$

$\varepsilon \leq 10$  percent for  $v < 30 \text{ km/h}$

5.2.2.3.2.6 The procedure described in clauses 5.2.2.3.2.1 to 5.2.2.3.2.5 of this chapter shall be repeated until the setting error satisfies the criteria. The chassis dynamometer setting and the observed errors shall be recorded.

- 5.2.2.4 The chassis dynamometer system shall comply with the calibration and verification methods laid down in Appendix 3.
- 5.2.3. **Calibration of analysers**
- 5.2.3.1 The quantity of gas at the indicated pressure compatible with the correct functioning of the equipment shall be injected into the analyser with the aid of the flow meter and the pressure-reducing valve mounted on each gas cylinder. The apparatus shall be adjusted to indicate as a stabilized value the value inserted on the standard gas cylinder. Starting from the setting obtained with the gas cylinder of greatest capacity, a curve shall be drawn of the deviations of the apparatus according to the content of the various standard cylinders used. The flame ionization analyser shall be recalibrated periodically, at intervals of not more than one month, using air/propane or air/hexane mixtures with nominal hydro- carbon concentrations equal to 50 percent and 90 percent of full scale.
- 5.2.3.2 Non-dispersive infrared absorption analyzers shall be checked at the same intervals using Nitrogen / CO and nitrogen/ CO<sub>2</sub> mixtures in nominal concentrations equal to 10, 40, 60, 85 and 90 percent of full scale.
- 5.2.3.3 To calibrate the NOX chemiluminescence analyzer, nitrogen/nitrogen oxide (NO) mixtures with nominal concentrations equal to 50 percent and 90 percent of full scale shall be used. The calibration of all three types of analysers shall be checked before each series of tests, using mixtures of the gases, which are measured in a concentration equal to 80 percent of full scale. A dilution device can be applied for diluting a 100 percent calibration gas to required concentration.
- 5.2.3.4. Flame ionization detector (FID) (analyzer) hydrocarbon response check procedure.
- 5.2.3.4.1. Detector response optimization
- The FID shall be adjusted according to the manufacturers' specifications. To optimize the response, propane in air shall be used on the most common operating range.
- 5.2.3.4.2. Calibration of the hydrocarbon analyzer
- The analyser shall be calibrated using propane in air and purified synthetic air (see clause 5.2.3.6 of this chapter).
- A calibration curve shall be established as described in clause 5.2.3.1 to 5.2.3.3 of this Chapter.
- 5.2.3.4.3. Response factors of different hydrocarbons and recommended limits
- The response factor (Rf) for a particular hydrocarbon species is the ratio of the FID C1 reading to the gas cylinder concentration, expressed as ppm C1.
- The concentration of the test gas shall be at a level to give a response of approximately 80 percent of full-scale deflection for the operating

range. The concentration shall be known to an accuracy of 2 percent in reference to a gravimetric standard expressed in volume. In addition, the gas cylinder shall be pre-conditioned for 24 hours at a temperature of between 293.2 K and 303.2 K (20 °C and 30 °C).

Response factors shall be determined when introducing an analyser into service and thereafter at major service intervals. The test gases to be used and the recommended response factors are:

Methane and purified air:  $1.00 < R_f < 1.15$

or  $1.00 < R_f < 1.05$  for NG/biomethane fueled vehicles

Propylene and purified air:  $0.90 < R_f < 1.00$

Toluene and purified air:  $0.90 < R_f < 1.00$

These are relative to a response factor ( $R_f$ ) of 1.00 for propane and purified air.

5.2.3.5 Calibration and verification procedures of the particulate mass emissions measurement equipment.

5.2.3.5.1. Flow meter calibration

The test agency shall check that a calibration certificate has been issued for the flow meter demonstrating compliance with a traceable standard within a 12-month period prior to the test, or since any repair or change which could influence calibration.

5.2.3.5.2. Microbalance calibration

The test agency shall check that a calibration certificate has been issued for the microbalance demonstrating compliance with a traceable standard within a 12-month period prior to the test.

5.2.3.5.3. Reference filter weighing

To determine the specific reference filter weights, at least two unused reference filters shall be weighed within eight hours of, but preferably at the same time as, the sample filter weighing. Reference filters shall be of the same size and material as the sample filter.

If the specific weight of any reference filters changes by more than  $\pm 5 \mu\text{g}$  between sample filter weighing, the sample filter and reference filters shall be reconditioned in the weighing room and then reweighed.

This shall be based on a comparison of the specific weight of the reference filter and the rolling average of that filter's specific weights.

The rolling average shall be calculated from the specific weights collected in the period since the reference filters were placed in the weighing room. The averaging period shall be between one day and 30 days.



Multiple reconditioning and re-weighing of the sample and reference filters are permitted up to 80 hours after the measurement of gases from the emissions test.

If, within this period, more than half the reference filters meet the  $\pm 5 \mu\text{g}$  criterion, the sample filter weighing can be considered valid.

If, at the end of this period, two reference filters are used and one filter fails to meet the  $\pm 5 \mu\text{g}$  criterion, the sample filter weighing may be considered valid provided that the sum of the absolute differences between specific and rolling averages from the two reference filters is no more than  $10 \mu\text{g}$ .

If fewer than half of the reference filters meet the  $\pm 5 \mu\text{g}$  criterion, the sample filter shall be discarded and the emissions test repeated. All reference filters shall be discarded and replaced within 48 hours.

In all other cases, reference filters shall be replaced at least every 30 days and in such a manner that no sample filter is weighed without comparison with a reference filters that has been in the weighing room for at least one day.

If the weighing room stability criteria outlined in clause 4.5.3.12.1.3.4 of this chapter are not met but the reference filter weighing meet the criteria listed in clause 5.2.3.5.3 of this chapter the vehicle manufacturer has the option of accepting the sample filter weights or voiding the tests, fixing the weighing room control system and re-running the test.

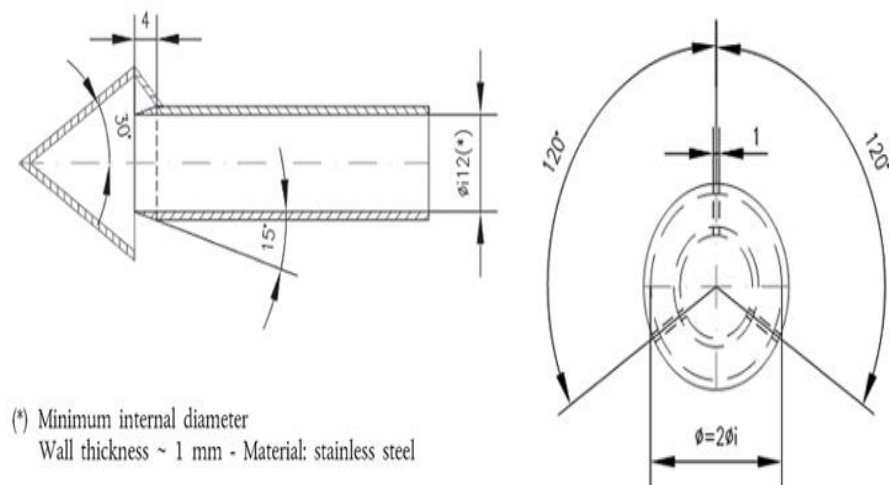

**Figure 7**

**Particulate sampling probe configuration**

5.2.3.6. Reference gases

5.2.3.6.1 Pure gases

The following pure gases shall be available, if necessary, for calibration and operation:

Purified nitrogen: (purity:  $\leq 1$  ppm C<sub>1</sub>,  $\leq 1$  ppm CO,  $\leq 400$  ppm CO<sub>2</sub>,  $\leq 0.1$  ppm NO);

Purified synthetic air: (purity:  $\leq 1$  ppm C<sub>1</sub>,  $\leq 1$  ppm CO,  $\leq 400$  ppm CO<sub>2</sub>,  $\leq 0.1$  ppm NO); oxygen content between 18 and 21 percent by volume;

Purified oxygen: (purity  $> 99.5$  percent vol. O<sub>2</sub>);

Purified hydrogen (and mixture containing helium): (purity  $\leq 1$  ppm C<sub>1</sub>,  $\leq 400$  ppm CO<sub>2</sub>); Carbon monoxide: (minimum purity 99.5 percent);

Propane: (minimum purity 99.5 percent).

5.2.3.6.2 Calibration and span gases

Mixtures of gases with the following chemical compositions shall be available:

C<sub>3</sub>H<sub>8</sub> and purified synthetic air;

CO and purified nitrogen;

CO<sub>2</sub> and purified nitrogen;

NO and purified nitrogen (the amount of NO<sub>2</sub> contained in this calibration gas shall not exceed 5 percent of the NO content).

The true concentration of a calibration gas shall be within  $\pm 2$  percent of the stated Figure of this Chapter

5.2.3.6.3 Calibration and verification of the dilution system

The dilution system shall be calibrated and verified and shall comply with the requirements of Appendix 4 of this Chapter.

5.2.4. **Test vehicle preconditioning**

5.2.4.1. The test vehicle shall be moved to the test area and the following operations performed:

The fuel tanks shall be drained through the drains of the fuel tanks provided and charged with the test fuel requirement as specified in the notification to half the capacity of the tanks.

The test vehicle shall be placed, either by being driven or pushed, on a dynamometer and operated through the applicable test cycle as specified for the vehicle sub-category in the notification and Appendix 6. The vehicle need not be cold, and may be used to set dynamometer power.

5.2.4.2. Practice runs over the prescribed driving schedule may be performed at test points, provided an emission sample is not taken, for the purpose of finding the minimum throttle action to maintain the proper speed-time relationship, or to permit sampling system adjustments.

5.2.4.3. Within five minutes of completion of preconditioning, the test vehicle shall be removed from the dynamometer and shall be pushed to the soak area to be parked. The vehicle shall be stored for between 6 and 36 hours prior to the cold start type I test or until the engine oil temperature  $T_O$  or the coolant temperature  $T_C$  or the sparkplug seat/gasket temperature  $T_p$  (only for air-cooled engine) equals the air temperature of the soak area within  $\pm 2K$ .

5.2.4.4. For the purpose of measuring particulates, between 6 and 36 hours before testing, the applicable test cycle as per notification shall be conducted. The technical details of the applicable test cycle are laid down in Appendix 6 of this chapter and the applicable test cycle shall also be used for vehicle pre-conditioning. Three consecutive cycles shall be driven. The dynamometer setting shall be indicated as in clause 4.5.6 of this chapter.

In a test facility where a test on a low particulate emitting vehicle could be contaminated by residue from a previous test on a high particulate emitting vehicle, it is recommended that, in order to pre-condition the sampling equipment, the low particulate emitting vehicle undergo a 20 minute 120 km/h steady state drive cycle or at 70% of the maximum design speed for vehicles not capable of attaining 120 km/h followed by three consecutive Part Two or Part Three WMTC cycles, if feasible.

After this preconditioning, and before testing, vehicles shall be kept in a room in which the temperature remains relatively constant between 293.20 K and 303.20 K (20 °C and 30 °C). This conditioning shall be carried out for at least six hours and continue until the engine oil temperature and coolant, if any, are within  $\pm 2K$  of the temperature of the room.

If the manufacturer so requests, the test shall be carried out not later than 30 hours after the vehicle has been run at its normal temperature.

5.2.4.5. At the request of the manufacturer, vehicles fitted with indirect injection positive-ignition engines may be preconditioned with one Part One, one Part Two and two Part Three driving cycles, if applicable, from the WMTC.

5.2.4.6. Vehicles equipped with a positive-ignition engine, fueled with other fuels LPG, NG/bio-methane,  $H_2NG$ , hydrogen or so equipped that they can be fueled with either petrol, LPG, NG/biomethane,  $H_2NG$  or hydrogen between the tests on the first gaseous reference fuel and the second gaseous reference fuel, shall be preconditioned before the test on the second reference fuel. This preconditioning on the second reference fuel shall involve a preconditioning cycle consisting of one Part One, Part Two and two Part Three WMTC cycles, as described in Appendix 6 of this Chapter. At the manufacturer's request and with the agreement of the test agency, this preconditioning may be extended. The dynamometer setting shall be as indicated in clause 4.5.6 of this Chapter.

**5.2.5. Emissions tests**

5.2.5.1. Engine starting and restarting

- 5.2.5.1.1. The engine shall be started according to the manufacturer's recommended starting procedures. The test cycle run shall begin when the engine starts.
- 5.2.5.1.2. Test vehicles equipped with automatic chokes shall be operated according to the instructions in the manufacturer's operating instructions or owner's manual covering choke-setting and 'kick-down' from cold fast idle. The transmission shall be put in gear, 15 seconds after the engine is started. If necessary, braking may be employed to keep the drive wheels from turning.
- 5.2.5.1.3. Test vehicles equipped with manual chokes shall be operated according to the manufacturer's operating instructions or owner's manual. Where times are provided in the instructions, the point for operation may be specified, within 15 seconds of the recommended time.
- 5.2.5.1.4. As per manufacturer request, during the idling phase The operator may use the choke, throttle, etc. where necessary to keep the engine running.
- 5.2.5.1.5. If the manufacturer's operating instructions or owner's manual do not specify a warm engine starting procedure, the engine (automatic and manual choke engines) shall be started by opening the throttle about half way and cranking the engine until it starts.
- 5.2.5.1.6. If, during the cold start, the test vehicle does not start after ten seconds of cranking or ten cycles of the manual starting mechanism, cranking shall cease and the reason for failure to start determined. The revolution counter on the constant volume sampler shall be turned off and the sample solenoid valves placed in the 'standby' position during this diagnostic period. In addition, either the CVS blower shall be turned off or the exhaust tube disconnected from the tailpipe during the diagnostic period.
- 5.2.5.1.7. In case of an operational error, that causes a delay in the starting of sampling collection at the initiation of engine start up procedure, the test vehicle shall be rescheduled for testing from a cold start.  
  
If failure to start is caused by vehicle malfunction and the vehicle cannot be started, the test shall be voided, the vehicle removed from the dynamometer, corrective action taken (following the unscheduled maintenance provisions) and the vehicle rescheduled for test from a cold start. The reason for the malfunction (if determined) and the corrective action taken shall be reported.
- 5.2.5.1.8. If the engine 'false starts', the operator shall repeat the recommended starting procedure (such as resetting the choke, etc.)

- 5.2.5.2. Stalling
- 5.2.5.2.1. Reserved
- 5.2.5.2.2. Reserved
- 5.2.6. **Drive instructions**
- 5.2.6.1. The test vehicle shall be driven with minimum throttle movement to maintain the desired speed. No simultaneous use of brake and throttle shall be permitted.
- 5.2.6.2. If the test vehicle cannot accelerate at the specified rate, it shall be operated with the throttle fully opened until the roller speed reaches the value prescribed for that time in the driving schedule
- 5.2.7. **Dynamometer test runs**
- 5.2.7.1 The complete dynamometer test consists of consecutive parts as described in clause 4.5.4 of this chapter.
- 5.2.7.2. The following steps shall be taken for each test:
- a) place drive wheel of vehicle on dynamometer without starting engine.
  - b) activate vehicle cooling fan;
  - c) for all test vehicles, with the sample selector valves in the 'standby' position, connect evacuated sample collection bags to the dilute exhaust and dilution air sample collection systems;
  - d) start the CVS (if not already on), the sample pumps and the temperature recorder. (The heat exchanger of the constant volume sampler, if used, and sample lines shall be preheated to their respective operating temperatures before the test begins);
  - e) adjust the sample flow rates to the desired flow rate and set the gas flow measuring devices to zero;
    - a. For gaseous bag (except hydrocarbon) samples, the minimum flow rate is 0.08 litre/second;
    - b. For hydrocarbon samples, the minimum flame ionization detection (FID) (or heated flame ionization detection (HFID) in the case of methanol-fueled vehicles) flow rate is 0.031 litre/second;
  - f) attach the flexible exhaust tube to the vehicle tailpipes;
  - g) start the gas flow measuring device, position the sample selector valves to direct the sample flow into the 'transient' exhaust sample bag, the 'transient' dilution air sample bag, turn the key on and start cranking the engine;
  - h) put the transmission in gear;
  - i) begin the initial vehicle acceleration of the driving schedule;

- j) operate the vehicle according to the driving cycles specified in clause 4.5.4 of this chapter;
- k) at the end of part 1 or part 1 in cold condition, simultaneously switch the sample flows from the first bags and samples to the second bags and samples, switch off gas flow measuring device No 1 and start gas flow measuring device No 2;
- l) in case of vehicles capable of running Part 3 of the WMTC, at the end of Part 2 simultaneously switch the sample flows from the second bags and samples to the third bags and samples, switch off gas flow measuring device No 2 and start gas flow measuring device No 3;
- m) before starting a new part, record the measured roll or shaft revolutions and reset the counter or switch to a second counter. As soon as possible, transfer the exhaust and dilution air samples to the analytical system and process the samples according to clause 6 of this chapter., obtaining a stabilized reading of the exhaust bag sample on all analysers within 20 minutes of the end of the sample collection phase of the test;
- n) turn the engine off two seconds after the end of the last part of the test;
- o) immediately after the end of the sample period, turn off the cooling fan;
- p) turn off the constant volume sampler (CVS) or critical-flow venturi (CFV) or disconnect the exhaust tube from the tailpipes of the vehicle;
- q) disconnect the exhaust tube from the vehicle tailpipes and remove the vehicle from the dynamo-meter;

## **6.0 ANALYSIS OF RESULTS**

### **6.1. Type I tests**

#### **6.1.1. Exhaust emission and fuel consumption analysis**

##### **6.1.1.1. Analysis of the samples contained in the bags**

The analysis shall begin as soon as possible, and in any event not later than 20 minutes after the end of the tests, in order to determine:

— the concentrations of hydrocarbons, carbon monoxide, nitrogen oxides and carbon dioxide in the sample of dilution air contained in bag(s) B;

— the concentrations of hydrocarbons, carbon monoxide, nitrogen oxides and carbon dioxide in the sample of diluted exhaust gases contained in bag(s) A.

6.1.1.2. Calibration of analyzers and concentration results

The analysis of the results has to be carried out in the following steps:

- a) prior to each sample analysis, the analyzer range to be used for each pollutant shall be set to zero with the appropriate zero gas;
- b) the analyzers are set to the calibration curves by means of span gases of nominal concentrations of 70 to 100 percent of the range;
- c) The analyzers' zeros are rechecked. If the reading differs by more than 2 percent of range from that set in (b), the procedure is repeated;
- d) the samples are analyzed;
- e) After the analysis, zero and span points are rechecked using the same gases. If the readings are within 2 percent of those in point (c), the analysis is considered acceptable;
- f) at all points in this section the flow-rates and pressures of the various gases shall be the same as those used during calibration of the analyzers;
- g) The Figure adopted for the concentration of each pollutant measured in the gases is that read off after stabilization on the measuring device.

6.1.1.3. Measuring the distance covered.

The distance (S) actually covered for a test part shall be calculated by multiplying the number of revolutions read from the cumulative counter (see clause 5.2.7 of this chapter) by the circumference of the roller. This distance shall be expressed in km.

6.1.1.4. Determination of the quantity of gas emitted

The reported test results shall be computed for each test and each cycle part by use of the following formulae. The results of all emission tests shall be rounded, using the 'rounding-off method' in ASTM E29-67, to the number of decimal places indicated by expressing the applicable standard to three significant figures.

6.1.1.4.1. Total volume of diluted gas

The total volume of diluted gas, expressed in m<sup>3</sup>/cycle part, adjusted to the reference conditions of 20<sup>0</sup>C and 101.3 kPa, is calculated by: -

Equation 32

$$V = V_0 * \frac{N * (P_a - P_i) * 293.2}{101.3 * (T_p + 293.2)}$$

where:

$V_0$  is the volume of gas displaced by pump P during one revolution, expressed in  $m^3$ /revolution. This volume is a function of the differences between the intake and output sections of the pump;

$N$  is the number of revolutions made by pump P during each part of the test;  $P_a$  is the ambient pressure in kPa;

$P_i$  is the average under-pressure during the test part in the intake section of pump P, expressed in kPa;

$T_P$  is the temperature (expressed in K) of the diluted gases during the test part, measured in the intake section of pump P.

#### 6.1.1.4.2. Hydrocarbons (HC)

The mass of unburned hydrocarbons emitted by the exhaust of the vehicle during the test shall be calculated using the following formula:

Equation33

$$HC_m = \frac{1}{S} * V * d_{HC} * \frac{HC_C}{10^6}$$

where:

$HC_m$  is the mass of hydrocarbons emitted during the test part, in mg/km;  $S$  is the distance defined in clause 6.1.1.3 of this chapter;

$V$  is the total volume, defined in clause 6.1.1.4.1 of this chapter;

$d_{HC}$  is the density of the hydrocarbons at reference temperature and pressure 20°C and 101.3 kPa);

$$\begin{aligned} d &= 0.588 * 10^3 \text{ mg/m}^3 \text{ for petrol (E5) (C}_1\text{H}_{1.89}\text{O}_{0.016}\text{);} \\ &= 869 * 10^3 \text{ mg/m}^3 \text{ for ethanol (E85) (C}_1\text{H}_{2.74}\text{O}_{0.385}\text{);} \\ &= 581 * 10^3 \text{ mg/m}^3 \text{ for diesel (B7)(C}_1\text{H}_{1.86}\text{O}_{0.005}\text{);} \\ &= 605 * 10^3 \text{ mg/m}^3 \text{ for LPG} \\ &= 665 * 10^3 \text{ mg/m}^3 \text{ for NG/biogas (C}_1\text{H}_4\text{);} \\ &= \frac{9.104 * A + 136}{1524.152 - 0.583 * A} * 10^6 \text{ mg/m}^3 \text{ for H}_2\text{NG} \end{aligned}$$

(This equation is based on atmospheric condition of 0°C and 101.3 Kpa)

(with  $A$  = NG/biomethane quantity within the  $H_2NG$  mixture in (volume %))

$HC_C$  is the concentration of diluted gases, expressed in parts per million (ppm) of carbon equivalent (e.g. the concentration in propane



multiplied by three), corrected to take account of the dilution air by the following equation:

Equation 34

$$HC_c = HC_e - HC_d * (1 - \frac{1}{DiF})$$

where

$HC_e$  is the concentration of hydrocarbons expressed in parts per million (ppm) of carbon equivalent, in the sample of diluted gases collected in bag(s) A;

$HC_d$  is the concentration of hydrocarbons expressed in parts per million (ppm) of carbon equivalent, in the sample of dilution air collected in bag(s) B;

DiF is the coefficient defined in clause 6.1.1.4.7 of this Chapter.

The non-methane hydrocarbon (NMHC) concentration is calculated as follows:

Equation 35

$$C_{NMHC} = C_{THC} - (Rf_{CH_4} * C_{CH_4})$$

where:

$C_{NMHC}$  = corrected concentration of NMHC in the diluted exhaust gas, expressed in ppm carbon equivalent;

$C_{THC}$  = concentration of total hydrocarbons (THC) in the diluted exhaust gas, expressed in ppm carbon equivalent and corrected by the amount of THC contained in the dilution air

$C_{CH_4}$  = concentration of methane (CH<sub>4</sub>) in the diluted exhaust gas, expressed in ppm carbon equivalent and corrected by the amount of CH<sub>4</sub> contained in the dilution air;

Rf CH<sub>4</sub> is the FID response factor to methane as defined in clause 5.2.3.4.1 of this Chapter.

#### 6.1.1.4.3 Carbon monoxide (CO)

The mass of carbon monoxide emitted by the exhaust of the vehicle during the test shall be calculated using the following formula:

Equation 36

$$CO_m = \frac{1}{S} * V * d_{CO} * \frac{CO_c}{10^6}$$

where:

$CO_m$  is the mass of carbon monoxide emitted during the test part, in mg/km;

S is the distance defined in clause 6.1.1.3 of this Chapter;

V is the total volume defined in clause 6.1.1.4.1 of this Chapter;

$d_{CO}$  is the density of the carbon monoxide,  $d_{CO} = 1.164 * 10^6$  mg/m<sup>3</sup> at reference temperature and pressure 20°C and 101.3 kPa;

$CO_c$  is the concentration of diluted gases, expressed in parts per million (ppm) of carbon monoxide, corrected to take account of the dilution air by the following equation

Equation 37

$$CO_c = CO_e - CO_d * \left(1 - \frac{1}{DiF}\right)$$

where:

$CO_e$  is the concentration of carbon monoxide expressed in parts per million (ppm), in the sample of diluted gases collected in bag(s) A;

$CO_d$  is the concentration of carbon monoxide expressed in parts per million (ppm), in the sample of dilution air collected in bag(s) B;

DiF is the coefficient defined in clause 6.1.1.4.7 of this Chapter.

#### 6.1.1.4.4. Nitrogen oxides (NO<sub>x</sub>)

The mass of nitrogen oxides emitted by the exhaust of the vehicle during the test shall be calculated using the following formula:

Equation 38

$$NO_{xm} = \frac{1}{S} * V * d_{NO_2} * \frac{NO_{xc} K_h}{10^6}$$

where:

$NO_{xm}$  is the mass of nitrogen oxides emitted during the test part, in mg/km;

S is the distance defined in clause 6.1.1.3 of this Chapter;

V is the total volume defined in clause 6.1.1.4.1 of this Chapter;

$d_{NO_2}$  is the density of the nitrogen oxides in the exhaust gases, assuming that they will be in the form of nitric oxide,  $d_{NO_2} = 1.913 * 10^6$  mg/m<sup>3</sup> at reference temperature and pressure 20°C and 101.3 kPa;

$NO_{xc}$  is the concentration of diluted gases, expressed in parts per million (ppm), corrected to take account of the dilution air by the following equation:

Equation 39

$$NO_{xc} = NO_{xe} - NO_{xd} * \left(1 - \frac{1}{DiF}\right)$$

where:

$NO_{xe}$  is the concentration of nitrogen oxides expressed in parts per million (ppm) of nitrogen oxides, in the sample of diluted gases collected in bag(s) A;

$NO_{xd}$  is the concentration of nitrogen oxides expressed in parts per million (ppm) of nitrogen oxides, in the sample of dilution air collected in bag(s) B;

DiF is the coefficient defined in clause 6.1.1.4.7 of this Chapter;

$K_h$  is the humidity correction factor, calculated using the following formula:

Equation 40

$$K_h = \frac{1}{1 - 0.0329 * (H - 10.7)}$$

Where:

H is the absolute humidity in g of water per kg of dry air:

Equation 41

$$H = \frac{6.2111 * U * P_d}{P_a - P_d \left(\frac{U}{100}\right)}$$

where:

U is the humidity as a percentage;

$P_d$  is the saturated pressure of water at the test temperature, in kPa;

$P_a$  is the atmospheric pressure in kPa.

#### 6.1.1.4.5. Particulate matter mass

Particulate emission  $M_p$  (mg/km) is calculated by means of the following equation:

Equation 42

$$M_p = \frac{(V_{mix} + V_{ep}) * P_e}{V_{ep} * S}$$

Where exhaust gases are vented outside the tunnel.

Equation 43

$$M_p = \frac{V_{mix} * P_e}{V_{ep} * S}$$

where exhaust gases are returned to the tunnel;

where:

$V_{mix}$  = volume V of diluted exhaust gases under standard conditions;

$V_{ep}$  = volume of exhaust gas flowing through particulate filter under standard conditions;

$P_e$  = particulate mass collected by filter(s) in mg;

$S$  = is the distance defined in clause 6.1.1.3 of this Chapter;

$M_p$  = particulate emission in mg/km.

Where correction for the particulate background level from the dilution system has been used, this shall be determined in accordance with clause 5.2.1.5 of this Chapter. In this case, the particulate mass (mg/km) shall be calculated as follows:

Equation 44

$$M_p = \left[ \frac{P_e}{V_{ep}} - \left( \frac{P_a}{V_{ap}} * \left( 1 - \frac{1}{DiF} \right) \right) \right] * \frac{(V_{mix} + V_{ep})}{S}$$

where exhaust gases are vented outside the tunnel;

Equation 45

$$M_p = \left[ \frac{P_e}{V_{ep}} - \left( \frac{P_a}{V_{ap}} * \left( 1 - \frac{1}{DiF} \right) \right) \right] * \frac{V_{mix}}{S}$$

where exhaust gases are returned to the tunnel;

where:

$V_{ap}$  = volume of tunnel air flowing through the background particulate filter under standard conditions;

$P_a$  = particulate mass collected by background filter;  $DiF$  = dilution factor defined in clause 6.1.1.4.7 of this Chapter.

Where application of a background correction results in a negative particulate mass (in mg/km), the result shall be considered to be zero mg/km particulate mass.

#### 6.1.1.4.6. Carbon dioxide ( $CO_2$ )

The mass of carbon dioxide emitted by the exhaust of the vehicle during the test shall be calculated using the following formula:

Equation 46

$$CO_{2m} = \frac{1}{S} * V * d_{CO_2} * \frac{CO_{2c}}{10^2}$$

where:

$CO_{2m}$  is the mass of carbon dioxide emitted during the test part, in g/km;  $S$  is the distance defined in clause 6.1.1.3 of this Chapter;

$V$  is the total volume defined in clause 6.1.1.4.1 of this Chapter;

$d_{CO_2}$  is the density of the carbon dioxide,  $d_{CO_2} = 1.830 \cdot 10^3 \text{ g/m}^3$  at reference temperature and pressure 20°C and 101.3 kPa;

$CO_{2c}$  is the concentration of diluted gases, expressed as a percentage of carbon dioxide equivalent, corrected to take account of the dilution air by the following equation:

Equation 47

$$CO_{2c} = CO_{2e} - CO_{2d} * (1 - \frac{1}{DiF})$$

where:

$CO_{2e}$  is the concentration of carbon dioxide expressed as a percentage of the sample of diluted gases collected in bag(s) A

$CO_{2d}$  is the concentration of carbon dioxide expressed as a percentage of the sample of dilution air collected in bag(s) B;

DiF is the coefficient defined in clause 6.1.1.4.7 of this Chapter

#### 6.1.1.4.7. Dilution factor ( DiF )

The dilution factor is calculated as follows:

For each reference fuel, except hydrogen:

Equation 48

$$DiF = \frac{X}{C_{CO_2} + (C_{HC} + C_{CO}) \cdot 10^{-4}}$$

For a fuel of composition  $C_xH_yO_z$ , the general formula is:

Equation 49

$$X = 100 \frac{x}{x + \frac{y}{2} + 3.76(x + \frac{y}{4} - \frac{z}{2})}$$

For  $H_2NG$ , the formula is:

Equation 50

$$X = \frac{65.4 * A}{4.922 * A + 195.84}$$

For hydrogen, the dilution factor is calculated as follows:

Equation 51

$$DiF = \frac{X}{C_{H_2O} - C_{H_2O-DA} + C_{H_2} * 10^{-4}}$$

For the reference fuels contained in Appendix x, the values of 'X' are as follows:

**Table 3**

Factor 'X' in formulae to calculate DiF

<b>Fuel</b>	<b>X</b>
Petrol (E5)	13.4
Diesel (B7)	13.5
LPG	11.9
NG/biomethane	9.5
Ethanol (E85)	12.5
Hydrogen	35.03
CNG X	9.5

In these equations:

$C_{CO_2}$  = concentration of  $CO_2$  in the diluted exhaust gas contained in the sampling bag, expressed in percent by volume,

$C_{HC}$  = concentration of HC in the diluted exhaust gas contained in the sampling bag, expressed in ppm carbon equivalent,

$C_{CO}$  = concentration of CO in the diluted exhaust gas contained in the sampling bag, expressed in ppm

$C_{H_2O}$  = concentration of  $H_2O$  in the diluted exhaust gas contained in the sampling bag, expressed in percent by volume,

$C_{H_2O-DA}$  = concentration of  $H_2O$  in the air used for dilution, expressed in percent by volume,

$C_{H_2}$  = concentration of hydrogen in the diluted exhaust gas contained in the sampling bag, expressed in ppm,

A = quantity of NG/bio-methane in the  $H_2NG$  mixture, expressed in percent by volume.

6.1.1.4.8 **Calculation of  $CO_2$  and fuel consumption values:**

6.1.1.4.8.1 The mass emission of  $CO_2$ , expressed in g/km, shall be calculated from the measurements taken in accordance with the provisions of clause 6 of Chapter 2.

6.1.1.4.8.1.1 For this calculation, the density of  $CO_2$  shall be assumed to be  $Q_{CO_2} = 1.830$  g/liter.

6.1.1.4.8.2 The fuel consumption values shall be calculated from the hydrocarbon, carbon monoxide and carbon dioxide emission measurements taken in accordance with the provisions of clause 6 of Chapter 2 in force at the time of the approval of the vehicle.

6.1.1.4.8.3. Fuel consumption (FC), expressed in liter per 100 km (in the case of petrol, LPG, ethanol (E85) and diesel) or m<sup>3</sup> per 100 km (in the case of an alternative fuel vehicle propelled with NG/bio-methane, H<sub>2</sub>NG or hydrogen it should be in m<sup>3</sup>/100km) is calculated using the following formulae:

6.1.1.4.8.3.1 for vehicles with a positive ignition engine fueled with petrol (E5):

Equation 52

$$FC = (0.118/D) * ((0.848 * HC) + (0.429 * CO) + (0.273 * CO_2));$$

6.1.1.4.8.3.2 for vehicles with a positive ignition engine fueled with LPG:

Equation 53

$$FC_{norm} = (0.1212/0.538) * ((0.825 * HC) + (0.429 * CO) + (0.273 * CO_2)).$$

If the composition of the fuel used for the test differs from that assumed for the calculation of normalized consumption, a correction factor (cf) may be applied at the manufacturer's request, as follows:

Equation 54

$$FC_{norm} = (0.1212/0.538) * (cf) * ((0.825 * HC) + (0.429 * CO) + (0.273 * CO_2)).$$

The correction factor is determined as follows:

Equation 55

$$cf = 0.825 + 0.0693 * n_{actual};$$

where:

$n_{actual}$  = the actual H/C ratio of the fuel used;

6.1.1.4.8.3.3 for vehicles with a positive ignition engine fueled with NG/biomethane:

Equation 56

$$FC_{norm} = (0.1336/0.654) * ((0.749 * HC) + (0.429 * CO) + (0.273 * CO_2)) \text{ in } m^3/100km;$$

6.1.1.4.8.3.4 for vehicles with a positive ignition engine fueled by H<sub>2</sub>NG:

Equation 57

$$FC = \frac{910.4 * A + 13600}{44655 * A^2 + 667.08 * A} \left( \frac{7848 * A}{9104 * A^2 + 136} * HC + 0.429 * CO + 0.273 * CO_2 \right) \text{ in } m^3/100km$$

6.1.1.4.8.3.5 for vehicles fueled with gaseous hydrogen

Equation 58

$$FC = 0.024 * \frac{V}{d} * \left[ \frac{1}{Z_2} * \frac{p_2}{T_2} - \frac{1}{Z_1} * \frac{p_1}{T_1} \right]$$

For vehicles fueled with gaseous or liquid hydrogen, the manufacturer may alternatively, with the prior agreement of the test agency, choose either the formula:

Equation 59

$$FC = 0.1 \cdot (0.1119 \cdot H_2O + H_2)$$

or a method in accordance with standard protocols such as SAE J2572.

- 6.1.1.4.8.3.6. for vehicles with a compression ignition engine fueled with diesel (B7)

Equation 60

$$FC = (0.116/D) \cdot ((0.861 \cdot HC) + (0.429 \cdot CO) + (0.273 \cdot CO_2));$$

- 6.1.1.4.8.3.7. for vehicles with a positive ignition engine fueled with ethanol (E85):

Equation 61

$$FC = (0.1742/D) \cdot ((0.574 \cdot HC) + (0.429 \cdot CO) + (0.273 \cdot CO_2)).$$

- 6.1.1.4.8.4. In these formulae:

FC= the fuel consumption in liters per 100 km in the case of petrol, ethanol, LPG, diesel or biodiesel, in m<sup>3</sup>

per 100 km in the case of natural gas and H<sub>2</sub>NG or in kg per 100 km in the case of hydrogen.

HC = the measured emission of hydrocarbons in mg/km

CO = the measured emission of carbon monoxide in mg/km

CO<sub>2</sub> = the measured emission of carbon dioxide in g/km

H<sub>2</sub>O = the measured emission of water (H<sub>2</sub>O) in g/km

H<sub>2</sub> = the measured emission of hydrogen (H<sub>2</sub>) in g/km

A = the quantity of NG/biomethane in the H<sub>2</sub>NG mixture, expressed in percent by volume

D = the density of the test fuel.

In the case of gaseous fuels, D is the density at 15<sup>0</sup>C and at 101.3 kPa ambient pressure:

d= theoretical distance covered by a vehicle tested under the type I test in km

p<sub>1</sub> = pressure in gaseous fuel tank before the operating cycle in Pa

p<sub>2</sub>= pressure in gaseous fuel tank after the operating cycle in Pa

T<sub>1</sub>=temperature in gaseous fuel tank before the operating cycle in K

T<sub>2</sub>=temperature in gaseous fuel tank after the operating cycle in K



$Z_1$ =compressibility factor of the gaseous fuel at  $p_1$  and  $T_1$

$Z_2$ =compressibility factor of the gaseous fuel at  $p_2$  and  $T_2$

$V$  = inner volume of the gaseous fuel tank in  $m^3$

The compressibility factor shall be obtained from the following table:

**Table 4:**

**Compressibility factor  $Z_x$  of the gaseous fuel**

T(k) \ p(bar)	5	100	200	300	400	500	600	700	800	900
33	0.8589	10.508	18.854	26.477	33.652	40.509	47.119	53.519	59.730	65.759
53	0.9651	0.9221	14.158	18.906	23.384	27.646	31.739	35.697	39.541	43.287
73	0.9888	0.9911	12.779	16.038	19.225	22.292	25.247	28.104	30.877	33.577
93	0.9970	10.422	12.334	14.696	17.107	19.472	21.771	24.003	26.172	28.286
113	10.004	10.659	12.131	13.951	15.860	17.764	19.633	21.458	23.239	24.978
133	10.019	10.757	11.990	13.471	15.039	16.623	18.190	19.730	21.238	22.714
153	10.026	10.788	11.868	13.123	14.453	15.804	17.150	18.479	19.785	21.067
173	10.029	10.785	11.757	12.851	14.006	15.183	16.361	17.528	18.679	19.811
193	10.030	10.765	11.653	12.628	13.651	14.693	15.739	16.779	17.807	18.820
213	10.028	10.705	11.468	12.276	13.111	13.962	14.817	15.669	16.515	17.352
233	10.035	10.712	11.475	12.282	13.118	13.968	14.823	15.675	16.521	17.358
248	10.034	10.687	11.413	12.173	12.956	13.752	14.552	15.350	16.143	16.929
263	10.033	10.663	11.355	12.073	12.811	13.559	14.311	15.062	15.808	16.548
278	10.032	10.640	11.300	11.982	12.679	13.385	14.094	14.803	15.508	16.207
293	10.031	10.617	11.249	11.897	12.558	13.227	13.899	14.570	15.237	15.900
308	10.030	10.595	11.201	11.819	12.448	13.083	13.721	14.358	14.992	15.623
323	10.029	10.574	11.156	11.747	12.347	12.952	13.559	14.165	14.769	15.370
338	10.028	10.554	11.113	11.680	12.253	12.830	13.410	13.988	14.565	15.138
353	10.027	10.535	11.073	11.617	12.166	12.718	13.272	13.826	14.377	14.926
Note: - In the case that the needed input values for p and T are not indicated in the table, the compressibility factor shall be obtained by linear interpolation between the compressibility factors indicated in the table, choosing the ones that are the closest to the sought value.										

**6.1.1.5. Weighting of type I test results**

6.1.1.5.1. With repeated measurements (see clause 5.1.1.2 of this Chapter), the pollutant (mg/km), and CO<sub>2</sub> (g/km) emission results obtained by the calculation method described in clause 6.1.1 of this Chapter are averaged for each cycle part.

## 6.1.1.5.1.1 Weighting of WMTC results

The (average) result of Part 1 or Part 1 reduced vehicle speed is called  $R_1$ , the (average) result of Part 2 or Part 2 reduced vehicle speed is called  $R_2$  and the (average) result of Part 3 or part 3 reduced vehicle speed is called  $R_3$ . Using these emission (mg/km) and fuel consumption (l/100km or m<sup>3</sup>/100Km) results, the final result  $R$ , depending on the vehicle category, shall be calculated using the following equations:

$$\text{Equation 62} \quad R = R_1 w_1 + R_2 w_2$$

where:

$w_1$  = weighting factor cold phase

$w_2$  = weighting factor warm phase

$$\text{Equation 63} \quad R = R_1 w_1 + R_2 w_2 + R_3 w_3$$

where:

$w_n$  = weighting factor phase  $n$  ( $n=1, 2$  or  $3$ )

The weighing factors for the vehicle classes shall be as per the notification.

## 7.0 RECORDS REQUIRED

The following information shall be recorded with respect to each test:

- a) Test number,
- b) System or device tested (brief description),
- c) Date and time of day for each part of the test schedule,
- d) Instrument operator,
- e) Rider or operator,
- f) Test vehicle: make, vehicle identification number, model year, transmission type, odometer reading at initiation of preconditioning, engine displacement, engine family, emission control system, recommended engine speed at idle, nominal fuel tank capacity, inertial loading, actual reference mass recorded at 0 kilometre, and drive wheel tyre pressure.
- g) Dynamometer serial number: as an alternative to recording the dynamometer serial number, a reference to a vehicle test cell number may be used, with the advance approval of the Test agency, provided the test cell records show the relevant instrument information.

- h) All relevant instrument information such as tuning, gain, serial number detector number, range. As an alternative, a reference to a vehicle test cell number may be used, with the advance approval of the test agencies, provided test cell calibration records show the relevant instrument information.
- i) Recorder charts: Identify zero point, span check, exhaust gas, and dilution air sample traces.
- j) Test cell barometric pressure, ambient temperature and humidity.

**Note:** A central laboratory barometer may be used; provided, that individual test cell barometric pressures are shown to be within  $\pm 0.1$  per cent of the barometric pressure at the central barometer location.

- k) Pressure of the mixture of exhaust and dilution air entering the CVS metering device, the pressure increase across the device, and the temperature at the inlet. The temperature shall be recorded continuously or digitally to determine temperature variations.
- l) The number of revolutions of the positive displacement pump accumulated during each test phase while exhaust samples are being collected. The number of standard cubic meters metered by a critical flow venturi (CFV) during each test phase would be the equivalent record for a CFV-CVS.
- m) The humidity of the dilution air.

**Note:** If conditioning columns are not used this measurement can be deleted. If the conditioning columns are used and the dilution air is taken from the test cell, the ambient humidity can be used for this measurement.

- n) The driving distance for each part of the test, calculated from the measured roll or shaft revolutions.
- o) The actual roller speed pattern of the test.
- p) The gear use schedule of the test.
- q) The emissions results of the Type I test for each part of the test and total weighted test results.
- r) The emissions results of the Type II test.

<b>APPENDIX 1 TO CHAPTER 2</b>		
<b>Symbols and Acronyms used</b>		
<b>Symbol</b>	<b>Definition</b>	<b>Unit</b>
a	Coefficient of polygonal function	—
$a_T$	Rolling resistance force of front wheel	N
b	Coefficient of polygonal function	—
$b_T$	Coefficient of aerodynamic function	$N/(km/h)^2$
c	Coefficient of polygonal function	—
$C_{CO}$	Concentration of carbon monoxide	percent vol.
$C_{COcorr}$	Corrected concentration of carbon monoxide	percent vol.
$CO_{2c}$	Carbon dioxide concentration of diluted gas, corrected to take account of diluent air	Percent
$CO_{2d}$	Carbon dioxide concentration in the sample of diluent air collected in bag B	Percent
$CO_{2e}$	Carbon dioxide concentration in the sample of diluent air collected in bag A	Percent
$CO_{2m}$	Mass of carbon dioxide emitted during the test part	g/km
$CO_c$	Carbon monoxide concentration of diluted gas, corrected to take account of diluent air	ppm
$CO_d$	Carbon monoxide concentration in the sample of diluent air, collected in bag B	ppm
	Carbon monoxide concentration in the sample of diluent air, collected in bag A	ppm
$CO_m$	Mass of carbon monoxide emitted during the test part	mg/km
$d_0$	Standard ambient relative air density	—
$d_{CO}$	Density of carbon monoxide	$mg/m^3$
$d_{CO_2}$	Density of carbon dioxide	$mg/m^3$
DiF	Dilution factor	—
$d_{HC}$	Density of hydrocarbon	$mg/m^3$
S / d	Distance driven in a cycle part	km
$d_{NO_X}$	Density of nitrogen oxide	$mg/m^3$
$d_T$	Relative air density under test condition	—
$\Delta t$	Coast-down time	s
$\Delta t_{ai}$	Coast-down time measured in the first road test	s
$\Delta t_{bi}$	Coast-down time measured in the second road	S

$\Delta T_E$	Coast-down time corrected for the inertia mass	s
$\Delta t_E$	Mean coast-down time on the chassis dynamometer at the reference speed	s
$\Delta T_i$	Average coast-down time at specified speed	s
$\Delta t_i$	Coast-down time at corresponding speed	s
$\Delta T_j$	Average coast-down time at specified speed	s
$\Delta T_{road}$	Target coast-down time	s
$\Delta t$	Mean coast-down time on the chassis	s
$\Delta v$	Coast-down speed interval ( $2\Delta v = v_1 - v_2$ )	km/h
$\varepsilon$	Chassis dynamometer setting error	percent
F	Running resistance force	N
F*	Target running resistance force	N
F*(v <sub>0</sub> )	Target running resistance force at reference speed on chassis dynamometer	N
F*(v <sub>i</sub> )	Target running resistance force at specified speed on chassis dynamometer	N
f* <sub>0</sub>	Corrected rolling resistance in the standard ambient condition	N
f* <sub>2</sub>	Corrected coefficient of aerodynamic drag in the standard ambient condition	N/(km/h) <sup>2</sup>
F*j	Target running resistance force at specified speed	N
f <sub>0</sub>	Rolling resistance	N
f <sub>2</sub>	Coefficient of aerodynamic drag	N/(km/h) <sup>2</sup>
F <sub>E</sub>	Set running resistance force on the chassis dynamometer	N
F <sub>E(v<sub>0</sub>)</sub>	Set running resistance force at the reference speed on the chassis dynamometer	N
F <sub>E(v<sub>2</sub>)</sub>	Set running resistance force at the specified speed on the chassis dynamometer	N
F <sub>f</sub>	Total friction loss	N
F <sub>f(v<sub>0</sub>)</sub>	Total friction loss at the reference speed	N
F <sub>j</sub>	Running resistance force	N
F <sub>j(v<sub>0</sub>)</sub>	Running resistance force at the reference speed	N
F <sub>pau</sub>	Braking force of the power absorbing unit	N
F <sub>pau(v<sub>0</sub>)</sub>	Braking force of the power absorbing unit at the reference speed	N
F <sub>pau(v<sub>j</sub>)</sub>	Braking force of the power absorbing unit at the specified speed	N

$F_T$	Running resistance force obtained from the running resistance table	N
H	Absolute humidity	mg/km
$HC_c$	Concentration of diluted gases expressed in the carbon equivalent, corrected to take account of diluent air	ppm
$HC_d$	Concentration of hydrocarbons expressed in the carbon equivalent, in the sample of diluent air collected in bag B	Ppm
$HC_e$	Concentration of hydrocarbons expressed in the carbon equivalent, in the sample of diluent air collected in bag A	ppm
$HC_m$	Mass of hydrocarbon emitted during the test part	mg/km
$K_0$	Temperature correction factor for rolling resistance	—
$K_h$	Humidity correction factor	—
L	Limit values of gaseous emission	mg/km
m	Test L2-category vehicle mass	kg
$m_a$	Actual mass of the test L2-category vehicle	kg
$m_{fi}$	Flywheel equivalent inertia mass	kg
$m_i$	Equivalent inertia mass	kg
$m_{ref}$	Mass in running order of the L2-category vehicle plus mass of rider (75 kg)	kg
$m_r$	Equivalent inertia mass of all the wheels	kg
$m_{ri}$	Equivalent inertia mass of all the rear wheel and L-category vehicle parts rotating with wheel	kg
$m_{rf}$	Rotating mass of the front wheel	kg
$m_{rid}$	Rider mass	kg
$m_k$	Unladen mass (L2 category)	kg
n	Engine speed	$\text{min}^{-1}$
n	Number of data regarding the emission or the test	—
N	Number of revolution made by pump P	—
ng	Number of forward gears	—
$n_{idle}$	Idling speed	$\text{min}^{-1}$
$n_{max\_acc}(1)$	Upshift speed from gear 1 to gear 2 during acceleration phases	$\text{min}^{-1}$
$n_{max\_acc}(i)$	Up shift speed from gear i to gear i+1 during acceleration phases, $i > 1$	$\text{min}^{-1}$
$n_{min\_acc}(i)$	Minimum engine speed for cruising or deceleration in gear 1	$\text{min}^{-1}$

NO <sub>xc</sub>	Nitrogen oxide concentration of diluted gases, corrected to take account of diluent air	ppm
NO <sub>xd</sub>	Nitrogen oxide concentration in the sample of diluent air collected in bag B	ppm
NO <sub>xe</sub>	Nitrogen oxide concentration in the sample of diluent air collected in bag A	ppm
NO <sub>xm</sub>	Mass of nitrogen oxides emitted during the test part	mg/km
P <sub>0</sub>	Standard ambient pressure	kPa
P <sub>a</sub>	Ambient/atmospheric pressure	kPa
P <sub>d</sub>	Saturated pressure of water at the test temperature	kPa
P <sub>i</sub>	Average under-pressure during the test part in the section of pump P	kPa
P <sub>n</sub>	Rated engine power	kW
P <sub>T</sub>	Mean ambient pressure during the test	kPa
ρ <sub>0</sub>	Standard relative ambient air volumetric mass	kg/m <sup>3</sup>
r(i)	Gear ratio in gear i	—
R	Final test result of pollutant emissions, carbon dioxide emission or fuel consumption	mg/km, g/km, 1/100 km
R <sub>1</sub>	Test results of pollutant emissions, carbon dioxide emission or fuel consumption for cycle part 1 with cold start	mg/km, g/km, 1/100 km
R <sub>2</sub>	Test results of pollutant emissions, carbon dioxide emission or fuel consumption for cycle part 2 with warm condition	mg/km, g/km, 1/100 km
R <sub>3</sub>	Test results of pollutant emissions, carbon dioxide emission or fuel consumption for cycle part 1 with warm condition	mg/km, g/km, 1/100 km
R <sub>i1</sub>	First type I test results of pollutant emissions	mg/km
R <sub>i2</sub>	Second type I test results of pollutant emissions	mg/km
R <sub>i3</sub>	Third type I test results of pollutant emissions	mg/km
s	Rated engine speed	min <sup>-1</sup>
T <sub>C</sub>	Temperature of the coolant	K
T <sub>O</sub>	Temperature of the engine oil	K
T <sub>P</sub>	Temperature of the spark-plug seat/gasket	K
T <sub>0</sub>	Standard ambient temperature	K

$T_p$	Temperature of the diluted gases during the test part, measured in the intake section of pump P	K
$T_T$	Mean ambient temperature during the test	K
U	Humidity	percent
v	Specified speed	
V	Total volume of diluted gas	$m^3$
$v_{max}$	Maximum design speed of test vehicle (L2 category vehicle)	km/h
$v_0$	Reference vehicle speed	km/h
$V_0$	Volume of gas displaced by pump P during one revolution	$m^3/rev.$
$v_1$	Vehicle speed at which the measurement of the coast-down time begins	km/h
$v_2$	Vehicle speed at which the measurement of the coast-down time ends	km/h
$v_i$	Specified vehicle speed selected for the coast-down time measurement	km/h
$w_1$	Weighting factor of cycle part 1 with cold start	—
$w_{1hot}$	Weighting factor of cycle part 1 with warm condition	—
$w_2$	Weighting factor of cycle part 2 with warm condition	—
$w_3$	Weighting factor of cycle part 3 with warm condition	—
LPG	liquefied petroleum gas	-
NG	natural gas	-
H <sub>2</sub> HCNG	hydrogen-natural gas mixtures	
CO	carbon monoxide	ppm
NO	nitric oxide	ppm
CO <sub>2</sub>	carbon dioxide	ppm
C <sub>3</sub> H <sub>8</sub>	Propane	ppm
$T_f$	temperature of fuel	°C
$T_v$	temperature of fuel vapour	°C
t	time from start of the fuel tank heat build	minutes
$m_{HC}$	mass of hydrocarbon emitted over the test phase	grams
$C_{HC}$	hydrocarbon concentration measured in the enclosure	ppm C1
T	ambient chamber temperature	K or °C
DF	deterioration factor for SHED test	mg/test
V	net enclosure volume corrected for the volume of the vehicle	$m^3$



p	barometric pressure	kPa
H/C	hydrogen to carbon ratio	-
m <sub>total</sub>	overall evaporative mass emissions of the vehicle	grams
m <sub>TH</sub>	evaporative hydrocarbon mass emission for the fuel tank heat build	grams
m <sub>HS</sub>	evaporative hydrocarbon mass emission for the hot soak	grams
v <sub>max</sub>	maximum vehicle speed	km/h
R <sub>f</sub>	response factor for a particular hydrocarbon species	-
FID	flame ionization detector	-
SHED	Sealed Housing for Evaporation Determination	-
HC	Hydrocarbon	-
NMHC	Non-methane Hydrocarbons	
RHC	Reactive Hydrocarbon	

<b>Table 2</b>		
<b>LIST OF ACRONYMS AND SYMBOLS</b>		
<b>Item</b>	<b>Unit</b>	<b>Term</b>
APS	-	accelerator (pedal / handle) position sensor
CAN	-	controller area network
CARB	-	California air resources board
CI	-	compression ignition engine
CO <sub>2</sub>	g/km	carbon dioxide
DTC		diagnostic trouble code
E85	-	ethanol blended petrol, up to 85% Ethanol
ECU	-	engine control unit
EPA	-	environmental protection agency, at USA federal level
ETC	-	electronic throttle control
HCNG	-	hydrogen-compressed natural gas mixtures
ID	-	Identifier
ISO	-	international standardization organization
LPG	-	liquefied petroleum gas
MI	-	malfunction indicator
NG	-	natural gas
ODX	-	open diagnostic data exchange
PCU	-	powertrain control unit
PI	-	positive ignition engine
PID	-	parameter identifier
SAE	-	society of automotive engineers, USA based globally active standardization organization
Test type I	-	test of tailpipe emissions after cold start
Test type V	-	test of durability of the vehicle's pollution control devices, mix of distance accumulation and test type I verification testing

Test type VIII	-	special test type I with induced fault mode to assess the impact on the tailpipe emission performance of a vehicle
TPS	-	throttle (accelerator actuator) position sensor
UDS	-	unified diagnostic services
VIN	-	vehicle identification number

**APPENDIX 2 TO CHAPTER 2**  
**Technical Specification of Reference Fuels**

**TECHNICAL SPECIFICATION OF REFERENCE FUELS**

- 1.1 Technical Specification of reference fuels shall be as per GSR 889(E) dated 16<sup>th</sup> Sep, 2016 as amended from time to time.

## APPENDIX 3 TO CHAPTER 2

### Chassis Dynamometer Systems

#### 1.0 SPECIFICATION

#### 1.1 General requirements

- 1.1.1 The dynamometer shall be capable of simulating road load within one of the following classifications:

dynamometer with fixed load curve, i.e. a dynamometer whose physical characteristics provide a fixed load curve shape;

Dynamometer with adjustable load curve, i.e. a dynamometer with at least two road load parameters that can be adjusted to shape the load curve.

- 1.1.2 Dynamometers with electric inertia simulation shall be demonstrated to be equivalent to mechanical inertia systems. The means by which equivalence is established are described in clause 4 of this Appendix.

- 1.1.3 Where the total resistance to progress on the road cannot be reproduced on the chassis dynamometer between speeds of 10 km/h and 120 km/h, it is recommended that a chassis dynamometer with the characteristics defined in clause 1.2 of this Appendix shall be used.

- 1.1.3.1 The load absorbed by the brake and the chassis dynamometer (internal frictional effects) between the speeds of 0 and 120 km/h is as follows:

Equation 1:

$$F = (a + b * v^2) \pm 0.1 * F_{80} \text{ (without being negative)}$$

where:

F= total load absorbed by the chassis dynamometer (N);

a= value equivalent to rolling resistance (N);

b= value equivalent to coefficient of air resistance (N/(km/h)<sup>2</sup>);

v= vehicle speed (km/h);

F<sub>80</sub> = load at 80 km/h (N). Alternatively, for vehicles that cannot attain 80 km/h the load at the reference vehicle speeds v<sub>j</sub> in table 1 of this Appendix and Chapter shall be determined.

**Table 1**

Category v <sub>max</sub> (km/h)	Applicable reference speed, v <sub>j</sub> (km/h)
70-80	50
45-70	40
25-45	30
<25	15

**1.2 SPECIFIC REQUIREMENTS**

- 1.2.1 The setting of the dynamometer shall not be affected by the lapse of time. It shall not produce any vibrations perceptible to the vehicle and likely to impair the vehicles' normal operations.
- 1.2.2 The chassis dynamometer may have one roller or two rollers/long single roller in case of vehicle with twinned wheel. In such cases, the front roller shall drive, directly or indirectly, the inertial masses and the power-absorption device.
- 1.2.3 It shall be possible to measure and read the indicated load to an accuracy of  $\pm 5$  percent.
- 1.2.4 In the case of a dynamometer with a fixed load curve, the accuracy of the load setting at 80 km/h or of the load setting at the reference vehicle speeds (30 km/h, respectively 15 km/h) referred to in clause 1.1.3.1 of this Appendix for vehicles that cannot attain 80 km/h, shall be  $\pm 5$  percent. In the case of a dynamometer with adjustable load curve, the accuracy of matching dynamometer load to road load shall be  $\pm 5$  percent for vehicle speeds  $> 20$  km/h and  $\pm 10$  percent for vehicle speeds  $\leq 20$  km/h. Below this vehicle speed, dynamometer absorption shall be positive.
- 1.2.5 The total inertia of the rotating parts (including the simulated inertia where applicable) shall be known and shall be within  $\pm 10$  kg of the inertia class for the test.
- 1.2.6 The speed of the vehicle shall be measured by the speed of rotation of the roller (the front roller in the case of a two-roller dynamometer). It shall be measured with an accuracy of  $\pm 1$  km/h at vehicle speeds over 10 km/h. The distance actually driven by the vehicle shall be measured by the movement of rotation of the roller (the front roller in the case of a two-roller dynamometer).

**2.0 DYNAMOMETER CALIBRATION PROCEDURE**

**2.1 Introduction**

This section describes the method to be used to determine the load absorbed by a dynamometer brake. The load absorbed comprises the load absorbed by frictional effects and the load absorbed by the power-absorption device. The dynamometer is brought into operation beyond the range of test speeds. The device used for starting up the dynamometer is then disconnected; the rotational speed of the driven roller decreases. The kinetic energy of the rollers is dissipated by the power-absorption unit and by the frictional effects. This method disregards variations in the rollers' internal frictional effects caused by rollers with or without the vehicle. The frictional effects of the rear roller shall be disregarded when the roller is free.

- 2.2 Calibration of the load indicator at 80 km/h or of the load indicator referred to in clause 1.1.3.1 of this Appendix for vehicles that cannot attain 80 km/h.

The following procedure shall be used for calibration of the load indicator to 80 km/h or the applicable load indicator referred to in clause 1.1.3.1 of this Appendix for vehicles that cannot attain 80 km/h, as a function of the load absorbed (see also Figure 1 of this Appendix):

- 2.2.1 Measure the rotational speed of the roller if this has not already been done. A fifth wheel, a revolution counter or some other method may be used.
- 2.2.2 Place the vehicle on the dynamometer or devise some other method for starting up the dynamometer.
- 2.2.3 Use the flywheel or any other system of inertia simulation for the particular inertia class to be used.

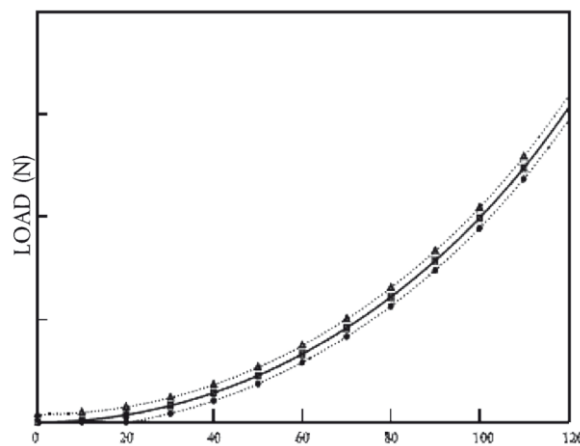

Figure 1

Power absorbed by the chassis dynamometer

Legend:

$$F = a + b \cdot v^2 \quad \bullet = (a + b \cdot v^2) - 0.1 \cdot F_{80} \quad \Delta = (a + b \cdot v^2) + 0.1 \cdot F_{80}$$

- 2.2.4 Bring the dynamometer to a vehicle speed of 80 km/h or to the reference vehicle speed referred to in clause 1.1.3.1 of this Appendix for vehicles that cannot attain 80 km/h.
- 2.2.5 Note the load indicated  $F_i$  (N).
- 2.2.6 Bring the dynamometer to a speed of 90 km/h or to the respective reference vehicle speed referred to in to in clause 1.1.3.1 of this Appendix plus 5 km/h for vehicles that cannot attain 80 km/h.
- 2.2.7 Disconnect the device used to start up the dynamometer.

2.2.8 Note the time taken by the dynamometer to pass from a vehicle speed of 85 to 75 km/h, or for vehicles that cannot attain 80 km/h referred to in Table 1 of this Appendix 7 of this Chapter note the time between  $v_j + 5$  km/h to  $v_j - 5$  km/h.

2.2.9 Set the power-absorption device at a different level.

2.2.10 The requirements of clauses 2.2.4 to 2.2.9 of this Appendix shall be repeated sufficiently often to cover the range of loads used.

2.2.11 Calculate the load absorbed using the formula:

Equation 2 
$$F = \frac{m_i * \Delta v}{\Delta t}$$

where:

F = load absorbed (N);

$m_i$  = equivalent inertia in kg (excluding the inertial effects of the free rear roller);

$\Delta v$  = vehicle speed deviation in m/s (10 km/h = 2.775 m/s);

$\Delta t$  = time taken by the roller to pass from 85 km/h to 75 km/h, or for vehicles that cannot attain 80 km/h from 35 – 25 km/h, respectively from 20 – 10 km/h, referred to in Table 1 of Appendix 7 of chapter 2

2.2.12 Figure 2 of this Appendix shows the load indicated at 80 km/h in terms of load absorbed at 80 km/h.

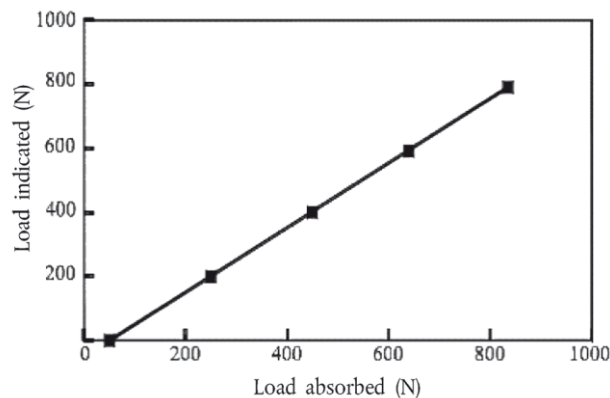

**Figure 2**  
**Load indicated at 80 km/h in terms of load absorbed at 80 km/h**

2.2.13 The requirements laid down in clauses 2.2.3 to 2.2.12 of this Appendix shall be repeated for all inertia classes to be used.

2.3 Calibration of the load indicator at other speeds

The procedures described in clause 2.2 of this Appendix shall be repeated as often as necessary for the chosen vehicle speeds.

2.4 Calibration of force or torque

The same procedure shall be used for force or torque calibration.



### 3 VERIFICATION OF THE LOAD CURVE

#### 3.1 Procedure

The load-absorption curve of the dynamometer from a reference setting at a speed of 80 km/h or for vehicles that cannot attain 80 km/h at the respective reference vehicle speeds referred to in clause 1.1.3.1 of this Appendix, shall be verified as follows:

- 3.1.1 Place the vehicle on the dynamometer or devise some other method for starting up the dynamometer.
- 3.1.2 Adjust the dynamometer to the absorbed load ( $F_{80}$ ) at 80 km/h, or for vehicles that cannot attain 80 km/h to the absorbed load  $F_{v_j}$  at the respective target vehicle speed  $v_j$  referred to in clause 1.1.3.1 of this Appendix.
- 3.1.3 Note the load absorbed at 120, 100, 80, 60, 40 and 20 km/h or for vehicles that cannot attain 80 km/h absorbed at the target vehicles speeds  $v_j$  referred to in clause 1.1.3.1 of this Appendix.
- 3.1.4 Draw the curve  $F(v)$  and verify that it corresponds to the requirements of clause 1.1.3.1 of this Appendix.
- 3.1.5 Repeat the procedure set out in clauses 3.1.1 to 3.1.4 of this Appendix for other values of  $F_{80}$  and for other values of inertia.

### 4 VERIFICATION OF SIMULATED INERTIA (SHIFT AFTER EXHAUST SYSTEM)

#### 4.1 Object

The method described in this Appendix makes it possible to check that the simulated total inertia of the dynamometer is carried out satisfactorily in the running phase of the operating cycle. The manufacturer of the chassis dynamometer shall specify a method for verifying the specifications according to clause 4.3 of this Appendix.

#### 4.2 Principle

##### 4.2.1 Drawing-up working equations

Since the dynamometer is subjected to variations in the rotating speed of the roller(s), the force at the surface of the roller(s) can be expressed by:

Equation 3:

$$F = I * \gamma = I_M * \gamma + F_1$$

where:

$F$  is the force at the surface of the roller(s) in N;

$I$  is the total inertia of the dynamometer (equivalent inertia of the vehicle);

$I_M$  is the inertia of the mechanical masses of the dynamometer;

$\gamma$  is the tangential acceleration at roller surface;  $F_1$  is the inertia force.

Thus, total inertia is expressed as follows:

Equation 4:  $I = I_m + F_1/\gamma$

where:

$I_m$  can be calculated or measured by traditional methods;

$F_1$  can be measured on the dynamometer;

$\gamma$  can be calculated from the peripheral speed of the rollers.

The total inertia (I) will be determined during an acceleration or deceleration test with values no lower than those obtained on an operating cycle.

4.2.2 Specification for the calculation of total inertia

The test and calculation methods shall make it possible to determine the total inertia I with a relative error ( $\Delta I/I$ ) of less than  $\pm 2$  percent.

4.3 **Specification**

4.3.1 The mass of the simulated total inertia I shall remain the same as the theoretical value of the equivalent inertia (see Appendix 5) within the following limits:

4.3.1.1  $\pm 5$  percent of the theoretical value for each instantaneous value;

4.3.1.2  $\pm 2$  percent of the theoretical value for the average value calculated for each sequence of the cycle.

The limit specified in clause 4.3.1.1 of this Appendix is brought to  $\pm 50$  percent for one second when starting and, for vehicles with manual transmission, for two seconds during gear change

4.4 **Verification procedure**

4.4.1 Verification is carried out during each test throughout the test cycles defined in Appendix 6 of Chapter 2.

4.4.2 However, if the requirements laid down in clause 4.3 of this Appendix are met, with instantaneous accelerations which are at least three times greater or smaller than the values obtained in the sequences of the theoretical cycle, the verification described in clause 4.4.1 of this Appendix will not be necessary.

**APPENDIX 4 TO CHAPTER 2****Exhaust Dilution System****1.0 SYSTEM SPECIFICATION****1.1 System overview**

A full-flow exhaust dilution system shall be used. This requires that the vehicle exhaust be continuously diluted with ambient air under controlled conditions. The total volume of the mixture of exhaust and dilution air shall be measured and a continuously proportional sample of the volume shall be collected for analysis. The quantities of pollutants are determined from the sample concentrations, corrected for the pollutant content of the ambient air and the totalized flow over the test period. The exhaust dilution system shall consist of a transfer tube, a mixing chamber and dilution tunnel, a dilution air conditioning, a suction device and a flow measurement device. Sampling probes shall be fitted in the dilution tunnel as specified in Appendices 3, 4 and 5. The mixing chamber described in this clause shall be a vessel, such as those illustrated in Figures 1 and 2 of this Appendix, in which vehicle exhaust gases and the dilution air are combined so as to produce a homogeneous mixture at the chamber outlet.

**1.2 General requirements**

- 1.2.1 The vehicle exhaust gases shall be diluted with a sufficient amount of ambient air to prevent any water condensation in the sampling and measuring system under any conditions which may occur during a test.
- 1.2.2 The mixture of air and exhaust gases shall be homogeneous at the point where the sampling probe is located (see clause 1.3.3 of this Appendix). The sampling probe shall extract a representative sample of the diluted exhaust gas.
- 1.2.3 The system shall enable the total volume of the diluted exhaust gases to be measured.
- 1.2.4 The sampling system shall be gas-tight. The design of the variable dilution sampling system and the materials that go to make it up shall be such that they do not affect the pollutant concentration in the diluted exhaust gases. Should any component in the system (heat exchanger, cyclone separator, blower, etc.) change the concentration of any of the pollutants in the diluted exhaust gases and the fault cannot be corrected, sampling for that pollutant shall be carried out upstream from that component.
- 1.2.5 All parts of the dilution system that are in contact with raw and diluted exhaust gas shall be designed to minimize deposition or alteration of the particulates or particles. All parts shall be made of electrically conductive materials that do not react with exhaust gas components and shall be electrically grounded to prevent electrostatic effects.

- 1.2.6 If the vehicle being tested is equipped with an exhaust pipe comprising several branches, the connecting tubes shall be connected as near as possible to the vehicle without adversely affecting its operation.
- 1.2.7 The variable-dilution system shall be designed so as to enable the exhaust gases to be sampled without appreciably changing the back-pressure at the exhaust pipe outlet.
- 1.2.8 The connecting tube between the vehicle and dilution system shall be so designed as to minimize heat loss.

**1.3 Specific requirements**

**1.3.1 Connection to vehicle exhaust**

The connecting tube between the vehicle exhaust outlets and the dilution system shall be as short as possible and satisfy the following requirements:

- a. the tube shall be less than 3.6 m long, or less than 6.1 m long if heat insulated. Its internal diameter may not exceed 105 mm;
- b. It shall not cause the static pressure at the exhaust outlets on the test vehicle to differ by more than  $\pm 0.75$  kPa at 50 km/h, or more than  $\pm 1.25$  kPa for the whole duration of the test, from the static pressures recorded when nothing is connected to the vehicle exhaust outlets. The pressure shall be measured in the exhaust outlet or in an extension having the same diameter, as near as possible to the end of the pipe. Sampling systems capable of maintaining the static pressure to within  $\pm 0.25$  kPa may be used if a written request from a manufacturer to the test agency substantiates the need for the closer tolerance;

it shall not change the nature of the exhaust gas;

any elastomeric connectors employed shall be as thermally stable as possible and have minimum exposure to the exhaust gases.

**1.3.2 Dilution air conditioning**

The dilution air used for the primary dilution of the exhaust in the CVS tunnel shall be passed through a medium capable of reducing particles in the most penetrating particle size of the filter material by  $\geq 99.95$  percent, or through a filter of at least class H13 of EN 1822:1998. This represents the specification of High Efficiency Particulate Air (HEPA) filters. The dilution air may be charcoal scrubbed before being passed to the HEPA filter. It is recommended that an additional coarse particle filter is situated before the HEPA filter and after the charcoal scrubber, if used. At the vehicle manufacturer's request, the dilution air may be sampled according to good engineering practice to determine the tunnel contribution to background particulate mass levels, which can then be subtracted from the values measured in the diluted exhaust.

### 1.3.3 Dilution tunnel

Provision shall be made for the vehicle exhaust gases and the dilution air to be mixed. A mixing orifice may be used. In order to minimize the effects on the conditions at the exhaust outlet and to limit the drop in pressure inside the dilution-air conditioning device, if any, the pressure at the mixing point shall not differ by more than  $\pm 0.25$  kPa from atmospheric pressure. The homogeneity of the mixture in any cross-section at the location of the sampling probe shall not vary by more than  $\pm 2$  percent from the average of the values obtained for at least five points located at equal intervals on the diameter of the gas stream. For particulate and particle emissions sampling, a dilution tunnel shall be used which:

shall consist of a straight tube of electrically-conductive material, which shall be earthed;

shall be small enough in diameter to cause turbulent flow (Reynolds number  $\geq 4\,000$ ) and of sufficient length to cause complete mixing of the exhaust and dilution air;

shall be at least 200 mm in diameter;

may be insulated.

### 1.3.4 Suction device

This device may have a range of fixed speeds to ensure sufficient flow to prevent any water condensation. This result is generally obtained if the flow is either:

- a. twice the maximum flow of exhaust gas produced by accelerations of the driving cycle; or
- b. sufficient to ensure that the CO<sub>2</sub> concentration in the dilute exhaust sample bag is less than 3 percent by volume for petrol and diesel, less than 2.2 percent by volume for LPG and less than 1.5 percent by volume for NG/biomethane.

### 1.3.5 Volume measurement in the primary dilution system

The method for measuring total dilute exhaust volume incorporated in the constant volume sampler shall be such that measurement is accurate to  $\pm 2$  percent under all operating conditions. If the device cannot compensate for variations in the temperature of the mixture of exhaust gases and dilution air at the measuring point, a heat exchanger shall be used to maintain the temperature to within  $\pm 6$  K of the specified operating temperature. If necessary, some form of protection for the volume measuring device may be used, e.g. a cyclone separator, bulk stream filter, etc. A temperature sensor shall be installed immediately before the volume measuring device. This sensor shall have an accuracy and a precision of  $\pm 1$  K and a response time of 0.1 s at 62 percent of a given temperature variation (value measured in silicone oil). The difference from atmospheric pressure shall be measured upstream and, if necessary, downstream from the volume measuring device. The pressure measurements shall have a precision and an accuracy of  $\pm 0.4$  kPa during the test.

## 1.4 Recommended system descriptions

Figure 1 and Figure 2 of this Appendix are schematic drawings of two types of recommended exhaust dilution systems that meet the requirements of this Chapter. Since various configurations can produce accurate results, exact conformity with these figures is not essential. Additional components such as instruments, valves, solenoids and switches may be used to provide additional information and coordinate the functions of the component system.

### 1.4.1 Full-flow dilution system with positive displacement pump

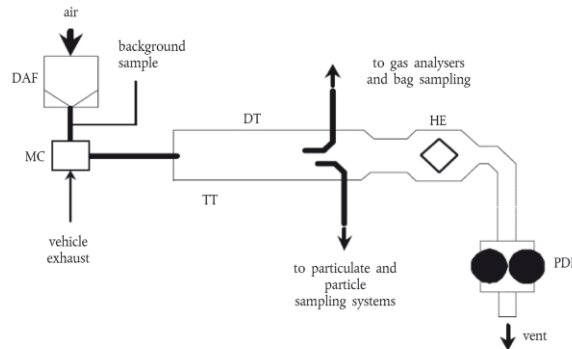

**Figure 1**

#### **Positive displacement pump dilution system**

The positive displacement pump (PDP) full-flow dilution system satisfies the requirements of this Chapter by metering the flow of gas through the pump at constant temperature and pressure. The total volume is measured by counting the revolutions of the calibrated positive displacement pump. The proportional sample is achieved by sampling with pump, flow meter and flow control valve at a constant flow rate. The collecting equipment consists of:

- 1.4.1.1 A filter (refer to DAF in Figure 1 of this Appendix) for the dilution air shall be installed, which can be preheated if necessary.

This filter shall consist of the following filters in sequence: an optional activated charcoal filter (inlet side) and a high efficiency particulate air (HEPA) filter (outlet side). It is recommended that an additional coarse particle filter is situated before the HEPA filter and after the charcoal filter, if used. The purpose of the charcoal filter is to reduce and stabilize the hydrocarbon concentrations of ambient emissions in the dilution air.

- 1.4.1.2 A transfer tube (TT) by which vehicle exhaust is admitted into a dilution tunnel (DT) in which the exhaust gas and dilution air are mixed homogeneously;

- 1.4.1.3 The positive displacement pump (PDP), producing a constant-volume flow of the air/exhaust-gas mixture. The PDP revolutions, together with associated temperature and pressure measurement, are used to determine the flow rate;

- 1.4.1.4 A heat exchanger (HE) of a capacity sufficient to ensure that throughout the test the temperature of the air/exhaust-gas mixture measured at a point immediately upstream of the positive displacement pump is within 6 K of the average operating temperature during the test. This device shall not affect the pollutant concentrations of diluted gases taken off afterwards for analysis.
- 1.4.1.5 A mixing chamber (MC) in which exhaust gas and air are mixed homogeneously and which may be located close to the vehicle so that the length of the transfer tube (TT) is minimized.
- 1.4.2 Full-flow dilution system with critical-flow venturi

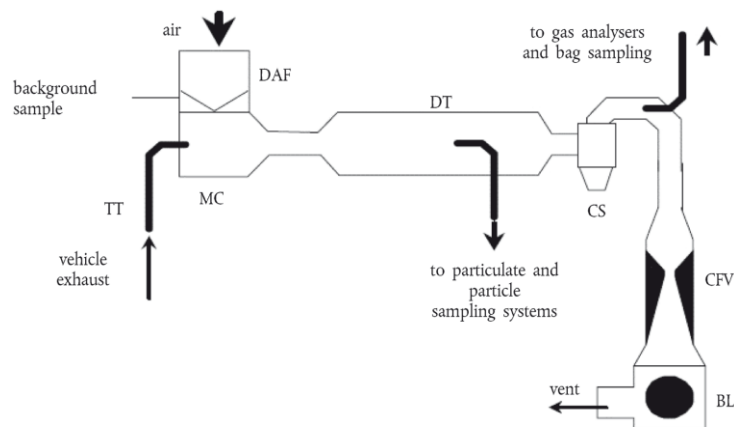

Figure 2

### Critical-flow venturi dilution system

The use of a critical-flow venturi (CFV) for the full-flow dilution system is based on the principles of flow mechanics for critical flow. The variable mixture flow rate of dilution and exhaust gas is maintained at sonic velocity which is directly proportional to the square root of the gas temperature. Flow is continually monitored, computed and integrated throughout the test. The use of an additional critical-flow sampling venturi ensures the proportionality of the gas samples taken from the dilution tunnel. As pressure and temperature are both equal at the two venturi inlets, the volume of the gas flow diverted for sampling is proportional to the total volume of diluted exhaust-gas mixture produced and thus the requirements of this Chapter are met. The collecting equipment consists of:

- 1.4.2.1 A filter (DAF) for the dilution air which can be preheated if necessary. This filter shall consist of the following filters in sequence: an optional activated charcoal filter (inlet side) and a high efficiency particulate air (HEPA) filter (outlet side). It is recommended that an additional coarse particle filter is situated before the HEPA filter and after the charcoal filter, if used. The purpose of the charcoal filter is to reduce and stabilize the hydrocarbon concentrations of ambient emissions in the dilution air;

- 1.4.2.2 A mixing chamber (MC) in which exhaust gas and air are mixed homogeneously and which may be located close to the vehicle so that the length of the transfer tube (TT) is minimized;
- 1.4.2.3 A dilution tunnel (DT) from which particulates and particles are sampled;
- 1.4.2.4 Some form of protection for the measurement system may be used, e.g. a cyclone separator, bulk stream filter, etc.;
- 1.4.2.5 A measuring critical-flow venturi tube (CFV) to measure the flow volume of the diluted exhaust gas;
- 1.4.2.6 A blower (BL) of sufficient capacity to handle the total volume of diluted exhaust gas.

## **2.0 CVS CALIBRATION PROCEDURE**

### **2.1 General requirements**

The CVS system shall be calibrated by using an accurate flow-meter and a restricting device. The flow through the system shall be measured at various pressure readings and the control parameters of the system measured and related to the flows. The flow-meter shall be dynamic and suitable for the high flow-rate encountered in CVS testing. The device shall be of certified accuracy traceable to an approved national or international standard.

- 2.1.1 Various types of flow-meter may be used, e.g. calibrated venturi, laminar flow-meter, calibrated turbine-meter, provided that they are dynamic measurement systems and can meet the requirements of clause 1.3.5 of this Appendix.
- 2.1.2 The following points give details of methods of calibrating PDP and CFV units, using a laminar flow-meter which gives the required accuracy, together with a statistical check on the calibration validity.

### **2.2 Calibration of the positive displacement pump (PDP)**

- 2.2.1 The following calibration procedure outlines the equipment, the test configuration and the various parameters that are measured to establish the flow-rate of the CVS pump. All the parameters relating to the pump are simultaneously measured with the parameters relating to the flow-meter which is connected in series with the pump. The calculated flow rate (given in  $\text{m}^3/\text{min}$  at pump inlet, absolute pressure and temperature) can then be plotted against a correlation function that is the value of a specific combination of pump parameters. The linear equation that relates the pump flow and the correlation function is then determined. If a CVS has a multiple speed drive, a calibration shall be performed for each range used.



- 2.2.2 This calibration procedure is based on the measurement of the absolute values of the pump and flow-meter parameters that relate to the flow rate at each point. Three conditions shall be maintained to ensure the accuracy and integrity of the calibration curve:
- 2.2.2.1 The pump pressures shall be measured at tappings on the pump rather than at the external piping on the pump inlet and outlet. Pressure taps that are mounted at the top centre and bottom centre of the pump drive head plate are exposed to the actual pump cavity pressures and therefore reflect the absolute pressure differentials;
- 2.2.2.2 Temperature stability shall be maintained during the calibration. The laminar flow-meter is sensitive to inlet temperature oscillations which cause the data points to be scattered. Gradual changes of  $\pm 1\text{K}$  in temperature are acceptable as long as they occur over a period of several minutes;
- 2.2.2.3 All connections between the flow-meter and the CVS pump shall be free of any leakage.
- 2.2.3 During an exhaust emission test, the measurement of these same pump parameters enables the user to calculate the flow rate from the calibration equation.
- 2.2.4 Figure 3 of this Appendix shows one possible test set-up. Variations are permissible, provided that the Test agency approves them as being of comparable accuracy. If the set-up shown in Figure 3 of this Appendix is used, the following data shall be found within the limits of precision given:

Barometric pressure (corrected) ( $P_b$ )  $\pm 0.03$  kPa

Ambient temperature (T)  $\pm 0.2$  °C

Air temperature at LFE (ETI)  $\pm 0.15$  °C

Pressure depression upstream of LFE (EPI)  $\pm 0.01$  kPa

Pressure drop across the LFE matrix (EDP)  $\pm 0.0015$  kPa

Air temperature at CVS pump inlet (PTI)  $\pm 0.2$  °C

Air temperature at CVS pump outlet (PTO)  $\pm 0.2$  °C

Pressure depression at CVS pump inlet (PPI)  $\pm 0.22$  kPa

Pressure head at CVS pump outlet (PPO)  $\pm 0.22$  kPa

Pump revolutions during test period (n)  $\pm 1$  min<sup>-1</sup>

Elapsed time for period (minimum 250 s) (t)  $\pm 0.1$  s

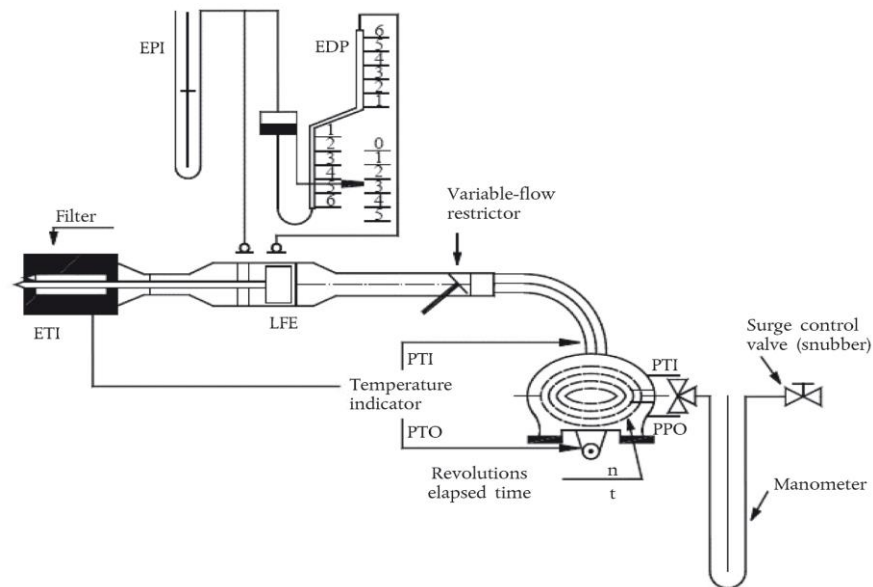

**Figure 3**

**PDP calibration configuration**

- 2.2.5 After the system has been connected as shown in Figure 3 of this Appendix, set the variable restrictor in the wide-open position and run the CVS pump for 20 minutes before starting the calibration.
- 2.2.6 Reset the restrictor valve to a more restricted condition in an increment of pump inlet depression (about 1 kPa) that will yield a minimum of six data points for the total calibration. Allow the system to stabilize for three minutes and repeat the data acquisition.
- 2.2.7 The air flow rate ( $Q_s$ ) at each test point is calculated in standard  $m^3/min$  from the flow-meter data using the manufacturer's prescribed method.
- 2.2.8 The air flow-rate is then converted to pump flow ( $V_0$ ) in  $m^3/rev$  at absolute pump inlet temperature and pressure.

Equation 1

$$V_0 = \frac{Q_s}{n} * \frac{T_p}{273.2} * \frac{101.33}{P_p}$$

where:

$V_0$  = pump flow rate at  $T_p$  and  $P_p$  ( $m^3/rev$ );

$Q_s$  = air flow at 101.33 kPa and 20<sup>0</sup>C ( $m^3/min$ );

$T_p$  = pump inlet temperature (K);

$P_p$  = absolute pump inlet pressure (kPa);

$n$  = pump speed ( $min^{-1}$ ).

- 2.2.9 To compensate for the interaction of pump speed pressure variations at the pump and the pump slip rate, the correlation function ( $x_0$ ) between the pump speed ( $n$ ), the pressure differential from pump inlet to pump outlet, and the absolute pump outlet pressure is calculated as follows:

Equation 2

$$x_0 = \frac{1}{n} \sqrt{\frac{\Delta P_p}{P_e}}$$

where:

$x_0$  = correlation function;

$\Delta P_p$  = pressure differential from pump inlet to pump outlet (kPa);

$P_e$  = absolute outlet pressure (PPO +  $P_b$ ) (kPa).

- 2.2.9.1 A linear least-square fit is performed to generate the calibration equations which have the formula:

Equation 3

$$V_0 = D_0 - M(x_0)$$

$$n = A - B(\Delta P_p)$$

$D_0$ ,  $M$ ,  $A$  and  $B$  are the slope-intercept constants describing the lines

- 2.2.10. A CVS system that has multiple speeds shall be calibrated on each speed used. The calibration curves generated for the ranges shall be approximately parallel and the intercept values ( $D_0$ ) shall increase as the pump flow range decreases.

- 2.2.11 If the calibration has been performed carefully, the calculated values from the equation will be within 0.5 percent of the measured value of  $V_0$ . Values of  $M$  will vary from one pump to another. Calibration is performed at pump start-up and after major maintenance.

## 2.3 CALIBRATION OF THE CRITICAL-FLOW VENTURE (CFV)

- 2.3.1 Calibration of the CFV is based on the flow equation for a critical-flow venturi:

Equation 4

$$Q_s = \frac{K_v P}{\sqrt{T}}$$

where:

$Q_s$  = flow  $m^3/min$ ;

$K_v$  = calibration coefficient;

$P$  = absolute pressure (kPa);

$T$  = absolute temperature ( $^{\circ}C$ ).

Gas flow is a function of inlet pressure and temperature. The calibration procedure described in clauses 2.3.2 to 2.3.7 of this Appendix shall establish the value of the calibration coefficient at measured values of pressure, temperature and air flow.

2.3.2 The manufacturer's recommended procedure shall be followed for calibrating electronic portions of the CFV.

2.3.3 Measurements for flow calibration of the critical-flow venturi are required and the following data shall be found within the limits of precision given:

Barometric pressure (corrected) ( $P_b$ )  $\pm 0.03$  kPa

LFE air temperature, flow-meter (ETI)  $\pm 0.15^{\circ}\text{C}$

Pressure depression upstream of LFE (EPI)  $\pm 0.01$  kPa

Pressure drop across (EDP) LFE matrix  $\pm 0.0015$  kPa

Air flow ( $Q_s$ )  $\pm 0.5$  percent

CFV inlet depression (PPI)  $\pm 0.02$  kPa

Temperature at venturi inlet ( $T_v$ )  $\pm 0.2^{\circ}\text{C}$ .

2.3.4 The equipment shall be set up as shown in Figure 4 of this Appendix and checked for leaks. Any leaks between the flow-measuring device and the critical-flow venturi will seriously affect the accuracy of the calibration.

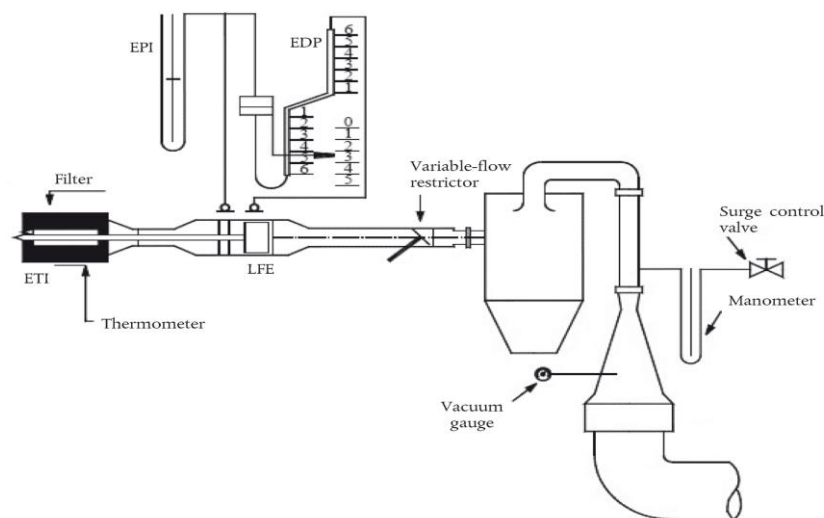

**Figure 4**

**CFV calibration configuration**

2.3.5 The variable-flow restrictor shall be set to the open position, the blower shall be started and the system stabilized. Data from all instruments shall be recorded.

- 2.3.6 The flow restrictor shall be varied and at least eight readings shall be taken across the critical flow range of the venturi.
- 2.3.7 The data recorded during the calibration shall be used in the following calculations. The air flow-rate ( $Q_s$ ) at each test point is calculated from the flow-meter data using the manufacturer's prescribed method. Calculate values of the calibration coefficient ( $K_v$ ) for each test point:

Equation 5

$$K_v = \frac{Q_s \sqrt{T_v}}{P_v}$$

$Q_s$  = flow-rate in  $m^3$  /min at 20°C and 101.3 kPa

$T_v$  = temperature at the venturi inlet (K);

$P_v$  = absolute pressure at the venturi inlet (kPa).

Plot  $K_v$  as a function of venturi inlet pressure. For sonic flow,  $K_v$  will have a relatively constant value. As pressure decreases (vacuum increases), the venturi becomes unchoked and  $K_v$  decreases. The resultant  $K_v$  changes are not permissible. For a minimum of eight points in the critical region, calculate an average  $K_v$  and the standard deviation. If the standard deviation exceeds 0.3 percent of the average  $K_v$ , take corrective action.

### **3.0 SYSTEM VERIFICATION PROCEDURE**

#### **3.1 General Requirements**

The total accuracy of the CVS sampling system and analytical system shall be determined by introducing a known mass of a pollutant gas into the system while it is being operated as if during a normal test and then analyzing and calculating the pollutant mass according to the formula in point 4, except that the density of propane shall be taken as 1.967 grams per litre at standard conditions. The two techniques described in clauses 3.2 and 3.3 of this Appendix are known to give sufficient accuracy. The maximum permissible deviation between the quantity of gas introduced and the quantity of gas measured is 5 percent.

#### **3.2 CFO Method**

- 3.2.1 Metering a constant flow of pure gas (CO or C<sub>3</sub>H<sub>8</sub>) using a critical-flow orifice device

3.2.2 A known quantity of pure gas (CO or C<sub>3</sub>H<sub>8</sub>) is fed into the CVS system through the calibrated critical orifice. If the inlet pressure is high enough, the flow-rate (q), which is adjusted by means of the critical-flow orifice, is independent of orifice outlet pressure (critical flow). If deviations exceeding 5 percent occur, the cause of the malfunction shall be determined and corrected. The CVS system is operated as in an exhaust emission test for about five to ten minutes. The gas collected in the sampling bag is analyzed by the usual equipment and the results compared to the concentration of the gas samples which was known beforehand.

3.3 **Gravimetric Method**

3.3.1 Metering a limited quantity of pure gas (CO or C<sub>3</sub>H<sub>8</sub>) by means of a gravimetric technique

3.3.2 The following gravimetric procedure may be used to verify the CVS system. The weight of a small cylinder filled with either carbon monoxide or propane is determined with a precision of  $\pm 0.01$  g. For about five to ten minutes, the CVS system is operated as in a normal exhaust emission test, while CO or propane is injected into the system. The quantity of pure gas involved is determined by means of differential weighing. The gas accumulated in the bag is analyzed using the equipment normally used for exhaust-gas analysis. The results are then compared to the concentration figures computed previously

## APPENDIX 5 TO CHAPTER 2

## Classification of equivalent inertia mass and running resistance

- 1.0 The chassis dynamometer can be set using the running resistance table instead of the running resistance force obtained by the coast-down methods set out in Appendix 7 of chapter 2.
- 2.0 The flywheel equivalent inertia mass  $m_{fi}$  shall be the equivalent inertia mass  $m_i$  specified in clause 4.5.6.1.2 of Chapter 2. The chassis dynamometer shall be set by the rolling resistance of front wheel 'a' and the aerodynamic drag coefficient 'b' specified in the following table.

Reference mass $m_{ref}$ (kg)	Equivalent inertia mass $m_i$ (kg)	Rolling resistance of front wheel a (N)	Aero drag coefficient b (N/(km/h) <sup>2</sup> )
$0 < m_{ref} \leq 25$	20	1.8	0.0203
$25 < m_{ref} \leq 35$	30	2.6	0.0205
$35 < m_{ref} \leq 45$	40	3.5	0.0206
$45 < m_{ref} \leq 55$	50	4.4	0.0208
$55 < m_{ref} \leq 65$	60	5.3	0.0209
$65 < m_{ref} \leq 75$	70	6.8	0.0211
$75 < m_{ref} \leq 85$	80	7.0	0.0212
$85 < m_{ref} \leq 95$	90	7.9	0.0214
$95 < m_{ref} \leq 105$	100	8.8	0.0215
$105 < m_{ref} \leq 115$	110	9.7	0.0217
$115 < m_{ref} \leq 125$	120	10.6	0.0218
$125 < m_{ref} \leq 135$	130	11.4	0.0220
$135 < m_{ref} \leq 145$	140	12.3	0.0221
$145 < m_{ref} \leq 155$	150	13.2	0.0223

$155 < \mathbf{m}_{\text{ref}} \leq 165$	160	14.1	0.0224
$165 < \mathbf{m}_{\text{ref}} \leq 175$	170	15.0	0.0226
$175 < \mathbf{m}_{\text{ref}} \leq 185$	180	15.8	0.0227
$185 < \mathbf{m}_{\text{ref}} \leq 195$	190	16.7	0.0229
$195 < \mathbf{m}_{\text{ref}} \leq 205$	200	17.6	0.0230
$205 < \mathbf{m}_{\text{ref}} \leq 215$	210	18.5	0.0232
$215 < \mathbf{m}_{\text{ref}} \leq 225$	220	19.4	0.0233
$225 < \mathbf{m}_{\text{ref}} \leq 235$	230	20.2	0.0235
$235 < \mathbf{m}_{\text{ref}} \leq 245$	240	21.1	0.0236
$245 < \mathbf{m}_{\text{ref}} \leq 255$	250	22.0	0.0238
$255 < \mathbf{m}_{\text{ref}} \leq 265$	260	22.9	0.0239
$265 < \mathbf{m}_{\text{ref}} \leq 275$	270	23.8	0.0241
$275 < \mathbf{m}_{\text{ref}} \leq 285$	280	24.6	0.0242
$285 < \mathbf{m}_{\text{ref}} \leq 295$	290	25.5	0.0244
$295 < \mathbf{m}_{\text{ref}} \leq 305$	300	26.4	0.0245
$305 < \mathbf{m}_{\text{ref}} \leq 315$	310	27.3	0.0247
$315 < \mathbf{m}_{\text{ref}} \leq 325$	320	28.2	0.0248
$325 < \mathbf{m}_{\text{ref}} \leq 335$	330	29.0	0.0250
$335 < \mathbf{m}_{\text{ref}} \leq 345$	340	29.9	0.0251
$345 < \mathbf{m}_{\text{ref}} \leq 355$	350	30.8	0.0253
$355 < \mathbf{m}_{\text{ref}} \leq 365$	360	31.7	0.0254
$365 < \mathbf{m}_{\text{ref}} \leq 375$	370	32.6	0.0256



$375 < m_{ref} \leq 385$	380	33.4	0.0257
$385 < m_{ref} \leq 395$	390	34.3	0.0259
$395 < m_{ref} \leq 405$	400	35.2	0.0260
$405 < m_{ref} \leq 415$	410	36.1	0.0262
$415 < m_{ref} \leq 425$	420	37.0	0.0263
$425 < m_{ref} \leq 435$	430	37.8	0.0265
$435 < m_{ref} \leq 445$	440	38.7	0.0266
$445 < m_{ref} \leq 455$	450	39.6	0.0268
$455 < m_{ref} \leq 465$	460	40.5	0.0269
$465 < m_{ref} \leq 475$	470	41.4	0.0271
$475 < m_{ref} \leq 485$	480	42.2	0.0272
$485 < m_{ref} \leq 495$	490	43.1	0.0274
$495 < m_{ref} \leq 505$	500	44.0	0.0275
At every 10 kg	At every 10 kg	$a = 0.088 \times m_j$ (*)	$b = 0.000015 \times m_j +$

(\*) The value shall be rounded to one decimal place.

(\*\*) The value shall be rounded to four decimal place

**APPENDIX 6 TO CHAPTER 2**  
**Driving cycles for Type I tests**

**1.0 WORLD HARMONIZED MOTORCYCLE TEST CYCLE (WMTC)-STAGE 2**

**Description of the test cycle**

The WMTC STAGE 2, to be used on the chassis dynamometer shall be as depicted in the following graph:

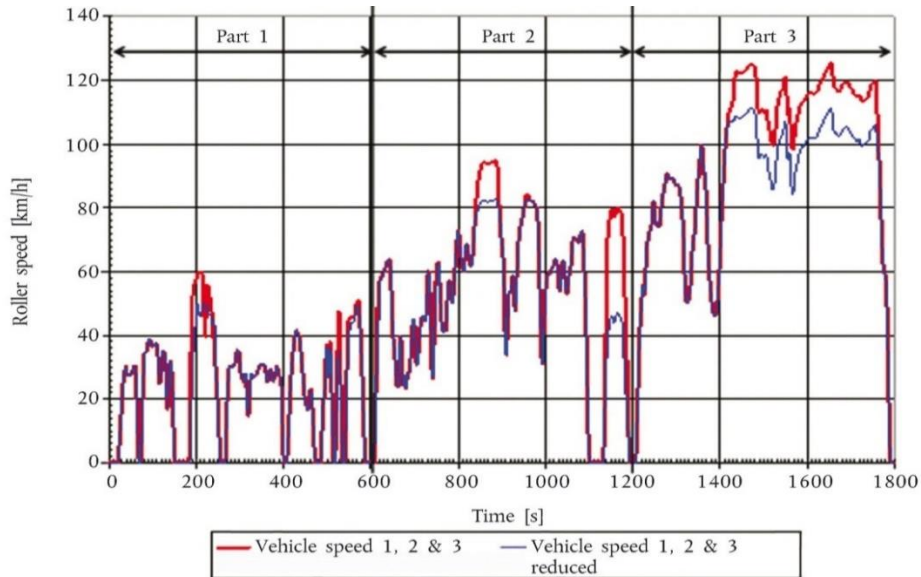

**Figure 1:**  
**WMTC**

- 1.1 The WMTC STAGE 2, with supplemental gear shift prescriptions. The WMTC STAGE 2, lasts 1800 seconds and consists of three parts to be carried out without interruption. The characteristic driving conditions (idling, acceleration, steady speed, deceleration, etc.) are set out in the following points and tables.

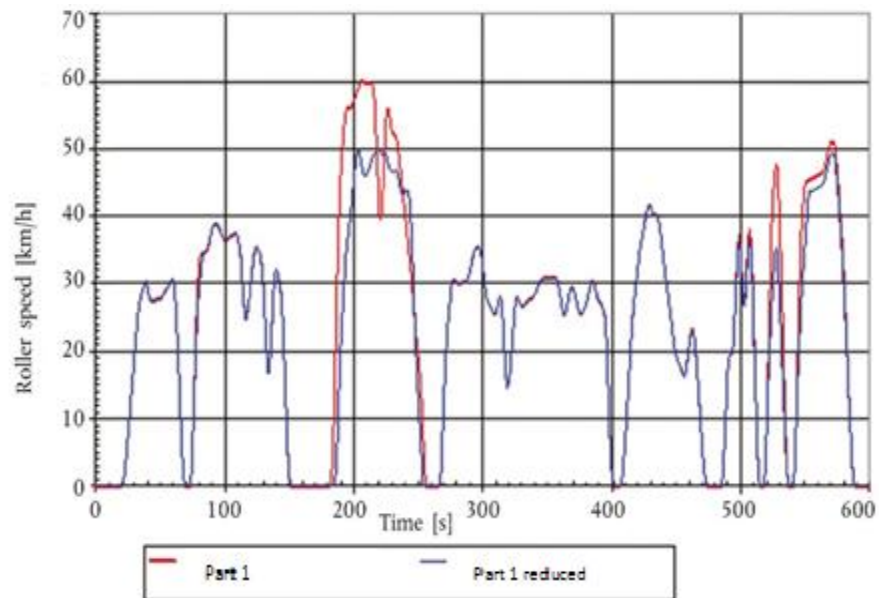
**2.0 WMTC STAGE 2, CYCLE PART 1**

**Figure 2:**  
**WMTC part 1**

- 2.1 The characteristic roller speed versus test time of WMTC STAGE 2, cycle part 1 is set out in the following tables.

2.2.1

Table 1: WMTC STAGE 2, cycle part 1, reduced speed, 0 to 180 s.																		
time in s	roller speed in km/h	phase indicators				time in s	roller speed in km/h	phase indicators				time in s	roller speed in km/h	phase indicators				
		stop	acc	cruise	dec			stop	acc	cruise	dec			stop	acc	cruise	dec	
0	0.0	X				61	29.6				X	121	31.2				X	
1	0.0	X				62	26.9				X	122	33.0				X	
2	0.0	X				63	23.0				X	123	34.4				X	
3	0.0	X				64	18.6				X	124	35.2				X	
4	0.0	X				65	14.1				X	125	35.4					X
5	0.0	X				66	9.3				X	126	35.2					X
6	0.0	X				67	4.8				X	127	34.7					X
7	0.0	X				68	1.9				X	128	33.9					X
8	0.0	X				69	0.0	X				129	32.4					X
9	0.0	X				70	0.0	X				130	29.8					X
10	0.0	X				71	0.0	X				131	26.1					X
11	0.0	X				72	0.0	X				132	22.1					X
12	0.0	X				73	0.0	X				133	18.6					X
13	0.0	X				74	1.7		X			134	16.8			X		
14	0.0	X				75	5.8		X			135	17.7			X		
15	0.0	X				76	11.8		X			136	21.1			X		
16	0.0	X				77	17.3		X			137	25.4			X		
17	0.0	X				78	22.0		X			138	29.2			X		
18	0.0	X				79	26.2		X			139	31.6			X		
19	0.0	X				80	29.4		X			140	32.1					X
20	0.0	X				81	31.1		X			141	31.6					X
21	0.0	X				82	32.9		X			142	30.7					X
22	1.0		X			83	34.7		X			143	29.7					X
23	2.6		X			84	34.8		X			144	28.1					X
24	4.8		X			85	34.8		X			145	25.0					X
25	7.2		X			86	34.9		X			146	20.3					X
26	9.6		X			87	35.4		X			147	15.0					X
27	12.0		X			88	36.2		X			148	9.7					X
28	14.3		X			89	37.1		X			149	5.0					X
29	16.6		X			90	38.0		X			150	1.6					X
30	18.9		X			91	38.7			X		151	0.0	X				
31	21.2		X			92	38.9			X		152	0.0	X				
32	23.5		X			93	38.9			X		153	0.0	X				
33	25.6		X			94	38.8			X		154	0.0	X				
34	27.1		X			95	38.5			X		155	0.0	X				
35	28.0		X			96	38.1			X		156	0.0	X				
36	28.7		X			97	37.5			X		157	0.0	X				
37	29.2		X			98	37.0			X		158	0.0	X				
38	29.8		X			99	36.7			X		159	0.0	X				
39	30.3			X		100	36.5			X		160	0.0	X				
40	29.6			X		101	36.5			X		161	0.0	X				
41	28.7			X		102	36.6			X		162	0.0	X				
42	27.9			X		103	36.8			X		163	0.0	X				
43	27.4			X		104	37.0			X		164	0.0	X				
44	27.3			X		105	37.1			X		165	0.0	X				
45	27.3			X		106	37.3			X		166	0.0	X				
46	27.4			X		107	37.4			X		167	0.0	X				
47	27.5			X		108	37.5			X		168	0.0	X				
48	27.6			X		109	37.4			X		169	0.0	X				
49	27.6			X		110	36.9			X		170	0.0	X				
50	27.6			X		111	36.0			X		171	0.0	X				
51	27.8			X		112	34.8			X		172	0.0	X				
52	28.1			X		113	31.9			X		173	0.0	X				
53	28.5			X		114	29.0			X		174	0.0	X				
54	28.9			X		115	26.9			X		175	0.0	X				
55	29.2			X		116	24.7			X		176	0.0	X				
56	29.4			X		117	25.4			X		177	0.0	X				
57	29.7			X		118	26.4			X		178	0.0	X				
58	30.0			X		119	27.7			X		179	0.0	X				
59	30.5			X		120	29.4			X		180	0.0	X				
60	30.6				X													

2.2.2

Table 2 : WMTC STAGE 2, cycle part 1, reduced speed, 181 to 360 s																	
time in s	roller speed km/h	phase indicators				time in s	roller speed km/h	phase indicators				time in s	roller speed km/h	phase indicators			
		stop	acc	cruise	dec			stop	acc	cruise	dec			stop	acc	cruise	dec
181	0.0	X				241	43.9			X		301	30.6			X	
182	0.0	X				242	43.8				X	302	29.0			X	
183	0.0	X				243	43.0				X	303	27.8			X	
184	0.0	X				244	40.9				X	304	27.2			X	
185	0.4		X			245	36.9				X	305	26.9			X	
186	1.8		X			246	32.1				X	306	26.5			X	
187	5.4		X			247	26.6				X	307	26.1			X	
188	11.1		X			248	21.8				X	308	25.7			X	
189	16.7		X			249	17.2				X	309	25.5			X	
190	21.3		X			250	13.7				X	310	25.7			X	
191	24.8		X			251	10.3				X	311	26.4			X	
192	28.4		X			252	7.0				X	312	27.3			X	
193	31.8		X			253	3.5				X	313	28.1			X	
194	34.6		X			254	0.0	X				314	27.9				X
195	36.3		X			255	0.0	X				315	26.0				X
196	37.8		X			256	0.0	X				316	22.7				X
197	39.6		X			257	0.0	X				317	19.0				X
198	41.3		X			258	0.0	X				318	16.0				X
199	43.3		X			259	0.0	X				319	14.6		X		
200	45.1		X			260	0.0	X				320	15.2		X		
201	47.5		X			261	0.0	X				321	16.9		X		
202	49.0		X			262	0.0	X				322	19.3		X		
203	50.0			X		263	0.0	X				323	22.0		X		
204	49.5			X		264	0.0	X				324	24.6		X		
205	48.8			X		265	0.0	X				325	26.8		X		
206	47.6			X		266	0.0	X				326	27.9		X		
207	46.5			X		267	0.5		X			327	28.0			X	
208	46.1			X		268	2.9		X			328	27.7			X	
209	46.1			X		269	8.2		X			329	27.1			X	
210	46.6			X		270	13.2		X			330	26.8			X	
211	46.9			X		271	17.8		X			331	26.6			X	
212	47.2			X		272	21.4		X			332	26.8			X	
213	47.8			X		273	24.1		X			333	27.0			X	
214	48.4			X		274	26.4		X			334	27.2			X	
215	48.9			X		275	28.4		X			335	27.4			X	
216	49.2			X		276	29.9		X			336	27.5			X	
217	49.6			X		277	30.5			X		337	27.7			X	
218	49.9			X		278	30.5			X		338	27.9			X	
219	50.0			X		279	30.3			X		339	28.1			X	
220	49.8			X		280	30.2			X		340	28.3			X	
221	49.5			X		281	30.1			X		341	28.6			X	
222	49.2			X		282	30.1			X		342	29.1			X	
223	49.3			X		283	30.1			X		343	29.6			X	
224	49.4			X		284	30.2			X		344	30.1			X	
225	49.4			X		285	30.2			X		345	30.6			X	
226	48.6			X		286	30.2			X		346	30.8			X	
227	47.8			X		287	30.2			X		347	30.8			X	
228	47.0			X		288	30.5			X		348	30.8			X	
229	46.9			X		289	31.0			X		349	30.8			X	
230	46.6			X		290	31.9			X		350	30.8			X	
231	46.6			X		291	32.8			X		351	30.8			X	
232	46.6			X		292	33.7			X		352	30.8			X	
233	46.9			X		293	34.5			X		353	30.8			X	
234	46.4			X		294	35.1			X		354	30.9			X	
235	45.6			X		295	35.5			X		355	30.9			X	
236	44.4			X		296	35.6			X		356	30.9			X	
237	43.5			X		297	35.4			X		357	30.8			X	
238	43.2			X		298	35.0			X		358	30.4			X	
239	43.3			X		299	34.0			X		359	29.6			X	
240	43.7			X		300	32.4			X		360	28.4			X	

## 2.2.3

Table 3 : WMTC STAGE 2, cycle part 1, reduced speed, 361 to 540 s																	
time in s	roller speed km/h	phase indicators				time in s	roller speed km/h	phase indicators				time in s	roller speed km/h	phase indicators			
		stop	acc	cruise	dec			stop	acc	cruise	dec			stop	acc	cruise	dec
361	27.1			X		421	34.0		X			481	0.0	X			
362	26.0			X		422	35.4		X			482	0.0	X			
363	25.4			X		423	36.5		X			483	0.0	X			
364	25.5			X		424	37.5		X			484	0.0	X			
365	26.3			X		425	38.6		X			485	0.0	X			
366	27.3			X		426	39.6		X			486	1.4		X		
367	28.3			X		427	40.7		X			487	4.5		X		
368	29.2			X		428	41.4		X			488	8.8		X		
369	29.5			X		429	41.7			X		489	13.4		X		
370	29.4			X		430	41.4			X		490	17.3		X		
371	28.9			X		431	40.9			X		491	19.2		X		
372	28.1			X		432	40.5			X		492	19.7		X		
373	27.1			X		433	40.2			X		493	19.8		X		
374	26.3			X		434	40.1			X		494	20.7		X		
375	25.7			X		435	40.1			X		495	23.7		X		
376	25.5			X		436	39.8				X	496	27.9		X		
377	25.6			X		437	38.9				X	497	31.9		X		
378	25.9			X		438	37.4				X	498	35.4		X		
379	26.3			X		439	35.8				X	499	36.2				X
380	26.9			X		440	34.1				X	500	34.2				X
381	27.6			X		441	32.5				X	501	30.2				X
382	28.4			X		442	30.9				X	502	27.1				X
383	29.3			X		443	29.4				X	503	26.6		X		
384	30.1			X		444	27.9				X	504	28.6		X		
385	30.4			X		445	26.5				X	505	32.6		X		
386	30.2			X		446	25.0				X	506	35.5		X		
387	29.5			X		447	23.4				X	507	36.6				X
388	28.6			X		448	21.8				X	508	34.6				X
389	27.9			X		449	20.3				X	509	30.0				X
390	27.5			X		450	19.3				X	510	23.1				X
391	27.2			X		451	18.7				X	511	16.7				X
392	26.9				X	452	18.3				X	512	10.7				X
393	26.4				X	453	17.8				X	513	4.7				X
394	25.7				X	454	17.4				X	514	1.2				X
395	24.9				X	455	16.8				X	515	0.0	X			
396	21.4				X	456	16.3					516	0.0	X			
397	15.9				X	457	16.5				X	517	0.0	X			
398	9.9				X	458	17.6				X	518	0.0	X			
399	4.9				X	459	19.2				X	519	3.0		X		
400	2.1				X	460	20.8				X	520	8.2		X		
401	0.9				X	461	22.2				X	521	14.3		X		
402	0.0	X				462	23.0				X	522	19.3		X		
403	0.0	X				463	23.0					523	23.5		X		
404	0.0	X				464	22.0					524	27.3		X		
405	0.0	X				465	20.1					525	30.8		X		
406	0.0	X				466	17.7					526	33.7		X		
407	0.0	X				467	15.0					527	35.2		X		
408	1.2		X			468	12.1					528	35.2				X
409	3.2		X			469	9.1					529	32.5				X
410	5.9		X			470	6.2					530	27.9				X
411	8.8		X			471	3.6					531	23.2				X
412	12.0		X			472	1.8					532	18.5				X
413	15.4		X			473	0.8					533	13.8				X
414	18.9		X			474	0.0	X				534	9.1				X
415	22.1		X			475	0.0	X				535	4.5				X
416	24.7		X			476	0.0	X				536	2.3				X
417	26.8		X			477	0.0	X				537	0.0	X			
418	28.7		X			478	0.0	X				538	0.0	X			
419	30.6		X			479	0.0	X				539	0.0	X			
420	32.4		X			480	0.0	X				540	0.0	X			

2.2.4.

**Table 4: WMTC STAGE 2, cycle part 1, reduced speed, 541 to 600 s**

time in s	roller speed in km/h	phase indicators			
		stop	Acc	cruise	Dec
541	0.0	X			
542	2.8		X		
543	8.1		X		
544	14.3		X		
545	19.2		X		
546	23.5		X		
547	27.2		X		
548	30.5		X		
549	33.1		X		
550	35.7		X		
551	38.3		X		
552	41.0		X		
553	43.6			X	
554	43.7			X	
555	43.8			X	
556	43.9			X	
557	44.0			X	
558	44.1			X	
559	44.2			X	
560	44.3			X	
561	44.4			X	
562	44.5			X	
563	44.6			X	
564	44.9			X	
565	45.5			X	
566	46.3			X	
567	47.1			X	
568	48.0			X	
569	48.7			X	
570	49.2			X	
571	49.4			X	
572	49.3			X	
573	48.7				X
574	47.3				X
575	45.0				X
576	42.3				X
577	39.5				X
578	36.6				X
579	33.7				X
580	30.1				X
581	26.0				X
582	21.8				X
583	17.7				X
584	13.5				X
585	9.4				X
586	5.6				X
587	2.1				X
588	0.0	X			
589	0.0	X			
590	0.0	X			
591	0.0	X			
592	0.0	X			
593	0.0	X			
594	0.0	X			
595	0.0	X			
596	0.0	X			
597	0.0	X			
598	0.0	X			
599	0.0	X			
600	0.0	X			

2.2.5

Table 5: WMTC STAGE 2, cycle part 1, 0 to 180 s																	
time in s	roller speed km/h	phase indicators				time in s	roller speed km/h	phase indicators				time in s	roller speed km/h	phase indicators			
		stop	acc	cruise	dec			stop	acc	cruise	dec			stop	acc	cruise	dec
0	0.0	X				61	29.7				X	121	31.0			X	
1	0.0	X				62	27.0				X	122	32.8			X	
2	0.0	X				63	23.0				X	123	34.3			X	
3	0.0	X				64	18.7				X	124	35.1			X	
4	0.0	X				65	14.2				X	125	35.3				X
5	0.0	X				66	9.4				X	126	35.1				X
6	0.0	X				67	4.9				X	127	34.6				X
7	0.0	X				68	2.0				X	128	33.7				X
8	0.0	X				69	0.0	X				129	32.2				X
9	0.0	X				70	0.0	X				130	29.6				X
10	0.0	X				71	0.0	X				131	26.0				X
11	0.0	X				72	0.0	X				132	22.0				X
12	0.0	X				73	0.0	X				133	18.5				X
13	0.0	X				74	1.7		X			134	16.6		X		
14	0.0	X				75	5.8		X			135	17.6		X		
15	0.0	X				76	11.8		X			136	21.0		X		
16	0.0	X				77	18.3		X			137	25.2		X		
17	0.0	X				78	24.5		X			138	29.1		X		
18	0.0	X				79	29.4		X			139	31.4		X		
19	0.0	X				80	32.5		X			140	31.9				X
20	0.0	X				81	34.2		X			141	31.4				X
21	0.0	X				82	34.4		X			142	30.6				X
22	1.0		X			83	34.5		X			143	29.5				X
23	2.6		X			84	34.6		X			144	28.0				X
24	4.8		X			85	34.7		X			145	24.9				X
25	7.2		X			86	34.8		X			146	20.2				X
26	9.6		X			87	35.2		X			147	14.8				X
27	12.0		X			88	36.0		X			148	9.5				X
28	14.3		X			89	37.0		X			149	4.8				X
29	16.6		X			90	37.9		X			150	1.4				X
30	18.9		X			91	38.6		X			151	0.0	X			
31	21.2		X			92	38.8			X		152	0.0	X			
32	23.5		X			93	38.8			X		153	0.0	X			
33	25.6		X			94	38.7			X		154	0.0	X			
34	27.1		X			95	38.5			X		155	0.0	X			
35	28.0		X			96	38.0			X		156	0.0	X			
36	28.7		X			97	37.4			X		157	0.0	X			
37	29.2		X			98	36.9			X		158	0.0	X			
38	29.8		X			99	36.6			X		159	0.0	X			
39	30.4			X		100	36.4			X		160	0.0	X			
40	29.6			X		101	36.4			X		161	0.0	X			
41	28.7			X		102	36.5			X		162	0.0	X			
42	27.9			X		103	36.7			X		163	0.0	X			
43	27.5			X		104	36.9			X		164	0.0	X			
44	27.3			X		105	37.0			X		165	0.0	X			
45	27.4			X		106	37.2			X		166	0.0	X			
46	27.5			X		107	37.3			X		167	0.0	X			
47	27.6			X		108	37.4			X		168	0.0	X			
48	27.6			X		109	37.3			X		169	0.0	X			
49	27.6			X		110	36.8			X		170	0.0	X			
50	27.7			X		111	35.8			X		171	0.0	X			
51	27.8			X		112	34.7			X		172	0.0	X			
52	28.1			X		113	31.8			X		173	0.0	X			
53	28.6			X		114	28.9			X		174	0.0	X			
54	29.0			X		115	26.7			X		175	0.0	X			
55	29.2			X		116	24.6			X		176	0.0	X			
56	29.5			X		117	25.2			X		177	0.0	X			
57	29.7			X		118	26.2			X		178	0.0	X			
58	30.1			X		119	27.6			X		179	0.0	X			
59	30.5			X		120	29.2			X		180	0.0	X			
60	30.7			X													



2.2.6

Table 6: WMTC STAGE 2, cycle part 1, 181 to 360 s																		
time in s	roller speed km/h	phase indicators				time in s	roller speed km/h	phase indicators				time in s	roller speed km/h	phase indicators				
		stop	acc	cruise	dec			stop	acc	cruise	dec			stop	acc	cruise	dec	
181	0.0	X				241	38.3				X	301	30.6				X	
182	0.0	X				242	36.4				X	302	28.9				X	
183	2.0		X			243	34.6				X	303	27.8				X	
184	6.0		X			244	32.7				X	304	27.2				X	
185	12.4		X			245	30.6				X	305	26.9				X	
186	21.4		X			246	28.1				X	306	26.5				X	
187	30.0		X			247	25.5				X	307	26.1				X	
188	37.1		X			248	23.1				X	308	25.7				X	
189	42.5		X			249	21.2				X	309	25.5				X	
190	46.6		X			250	19.5				X	310	25.7				X	
191	49.8		X			251	17.8				X	311	26.4				X	
192	52.4		X			252	15.3				X	312	27.3				X	
193	54.4		X			253	11.5				X	313	28.1				X	
194	55.6		X			254	7.2				X	314	27.9					X
195	56.1			X		255	2.5				X	315	26.0					X
196	56.2			X		256	0.0	X				316	22.7					X
197	56.2			X		257	0.0	X				317	19.0					X
198	56.2			X		258	0.0	X				318	16.0					X
199	56.7			X		259	0.0	X				319	14.6		X			
200	57.2			X		260	0.0	X				320	15.2		X			
201	57.7			X		261	0.0	X				321	16.9		X			
202	58.2			X		262	0.0	X				322	19.3		X			
203	58.7			X		263	0.0	X				323	22.0		X			
204	59.3			X		264	0.0	X				324	24.6		X			
205	59.8			X		265	0.0	X				325	26.8		X			
206	60.0			X		266	0.0	X				326	27.9		X			
207	60.0			X		267	0.5		X			327	28.1				X	
208	59.9			X		268	2.9		X			328	27.7				X	
209	59.9			X		269	8.2		X			329	27.2				X	
210	59.9			X		270	13.2		X			330	26.8				X	
211	59.9			X		271	17.8		X			331	26.6				X	
212	59.9			X		272	21.4		X			332	26.8				X	
213	59.8			X		273	24.1		X			333	27.0				X	
214	59.6				X	274	26.4		X			334	27.2				X	
215	59.1				X	275	28.4		X			335	27.4				X	
216	57.1				X	276	29.9		X			336	27.6				X	
217	53.2				X	277	30.5		X			337	27.7				X	
218	48.3				X	278	30.5			X		338	27.9				X	
219	43.9				X	279	30.3			X		339	28.1				X	
220	40.3				X	280	30.2			X		340	28.3				X	
221	39.5				X	281	30.1			X		341	28.6				X	
222	41.3		X			282	30.1			X		342	29.0				X	
223	45.2		X			283	30.1			X		343	29.6				X	
224	50.1		X			284	30.1			X		344	30.1				X	
225	53.7		X			285	30.1			X		345	30.5				X	
226	55.8		X			286	30.1			X		346	30.7				X	
227	55.8				X	287	30.2			X		347	30.8				X	
228	54.7				X	288	30.4			X		348	30.8				X	
229	53.3				X	289	31.0			X		349	30.8				X	
230	52.3				X	290	31.8			X		350	30.8				X	
231	52.0				X	291	32.7			X		351	30.8				X	
232	52.1				X	292	33.6			X		352	30.8				X	
233	51.8				X	293	34.4			X		353	30.8				X	
234	50.8				X	294	35.0			X		354	30.9				X	
235	49.2				X	295	35.4			X		355	30.9				X	
236	47.5				X	296	35.5			X		356	30.9				X	
237	45.7				X	297	35.3			X		357	30.8				X	
238	43.9				X	298	34.9			X		358	30.4				X	
239	42.0				X	299	33.9			X		359	29.6				X	
240	40.2				X	300	32.4			X		360	28.4				X	

2.2.7

Table 6: WMTC STAGE 2, cycle part 1, 181 to 360 s																	
time in s	roller speed km/h	phase indicators				time in s	roller speed km/h	phase indicators				time in s	roller speed km/h	phase indicators			
		stop	acc	cruise	dec			stop	acc	cruise	dec			stop	acc	cruise	dec
361	27.1			X		421	34.0		X			481	0.0	X			
362	26.0			X		422	35.4		X			482	0.0	X			
363	25.4			X		423	36.5		X			483	0.0	X			
364	25.5			X		424	37.5		X			484	0.0	X			
365	26.3			X		425	38.6		X			485	0.0	X			
366	27.3			X		426	39.7		X			486	1.4		X		
367	28.4			X		427	40.7		X			487	4.5		X		
368	29.2			X		428	41.5		X			488	8.8		X		
369	29.5			X		429	41.7			X		489	13.4		X		
370	29.5			X		430	41.5			X		490	17.3		X		
371	29.0			X		431	41.0			X		491	19.2		X		
372	28.1			X		432	40.6			X		492	19.7		X		
373	27.2			X		433	40.3			X		493	19.8		X		
374	26.3			X		434	40.2			X		494	20.7		X		
375	25.7			X		435	40.1			X		495	23.6		X		
376	25.5			X		436	39.8			X		496	28.1		X		
377	25.6			X		437	38.9			X		497	32.8		X		
378	26.0			X		438	37.5			X		498	36.3		X		
379	26.4			X		439	35.8			X		499	37.1				X
380	27.0			X		440	34.2			X		500	35.1				X
381	27.7			X		441	32.5			X		501	31.1				X
382	28.5			X		442	30.9			X		502	28.0				X
383	29.4			X		443	29.4			X		503	27.5		X		
384	30.2			X		444	28.0			X		504	29.5		X		
385	30.5			X		445	26.5			X		505	34.0		X		
386	30.3			X		446	25.0			X		506	37.0		X		
387	29.5			X		447	23.5			X		507	38.0				X
388	28.7			X		448	21.9			X		508	36.1				X
389	27.9			X		449	20.4			X		509	31.5				X
390	27.5			X		450	19.4			X		510	24.5				X
391	27.3			X		451	18.8			X		511	17.5				X
392	27.0				X	452	18.4			X		512	10.5				X
393	26.5				X	453	18.0			X		513	4.5				X
394	25.8				X	454	17.5			X		514	1.0				X
395	25.0				X	455	16.9			X		515	0.0	X			
396	21.5				X	456	16.4			X		516	0.0	X			
397	16.0				X	457	16.6			X		517	0.0	X			
398	10.0				X	458	17.7			X		518	0.0	X			
399	5.0				X	459	19.4			X		519	2.9		X		
400	2.2				X	460	20.9			X		520	8.0		X		
401	1.0				X	461	22.3			X		521	16.0		X		
402	0.0	X				462	23.2			X		522	24.0		X		
403	0.0	X				463	23.2			X		523	32.0		X		
404	0.0	X				464	22.2			X		524	38.8		X		
405	0.0	X				465	20.3			X		525	43.1		X		
406	0.0	X				466	17.9			X		526	46.0		X		
407	0.0	X				467	15.2			X		527	47.5				X
408	1.2		X			468	12.3			X		528	47.5				X
409	3.2		X			469	9.3			X		529	44.8				X
410	5.9		X			470	6.4			X		530	40.1				X
411	8.8		X			471	3.8			X		531	33.8				X
412	12.0		X			472	2.0			X		532	27.2				X
413	15.4		X			473	0.9			X		533	20.0				X
414	18.9		X			474	0.0	X				534	12.8				X
415	22.1		X			475	0.0	X				535	7.0				X
416	24.8		X			476	0.0	X				536	2.2				X
417	26.8		X			477	0.0	X				537	0.0	X			
418	28.7		X			478	0.0	X				538	0.0	X			
419	30.6		X			479	0.0	X				539	0.0	X			
420	32.4		X			480	0.0	X				540	0.0	X			

2.2.8

<b>Table 8 : WMTC STAGE 2, cycle part 1, 541 to 600 s</b>					
time in s	roller speed in km/h	phase indicators			
		stop	acc	cruise	dec
541	0.0	X			
542	2.7		X		
543	8.0		X		
544	16.0		X		
545	24.0		X		
546	32.0		X		
547	37.2		X		
548	40.4		X		
549	43.1		X		
550	44.6		X		
551	45.2			X	
552	45.3			X	
553	45.4			X	
554	45.5			X	
555	45.6			X	
556	45.7			X	
557	45.8			X	
558	45.9			X	
559	46.0			X	
560	46.1			X	
561	46.2			X	
562	46.3			X	
563	46.4			X	
564	46.7			X	
565	47.2			X	
566	48.0			X	
567	48.9			X	
568	49.8			X	
569	50.5			X	
570	51.0			X	
571	51.1			X	
572	51.0			X	
573	50.4				X
574	49.0				X
575	46.7				X
576	44.0				X
577	41.1				X
578	38.3				X
579	35.4				X
580	31.8				X
581	27.3				X
582	22.4				X
583	17.7				X
584	13.4				X
585	9.3				X
586	5.5				X
587	2.0				X
588	0.0	X			
589	0.0	X			
590	0.0	X			
591	0.0	X			
592	0.0	X			
593	0.0	X			
594	0.0	X			
595	0.0	X			
596	0.0	X			
597	0.0	X			
598	0.0	X			
599	0.0	X			
600	0.0	X			

**3.0 WMTC STAGE 2, CYCLE PART 2**

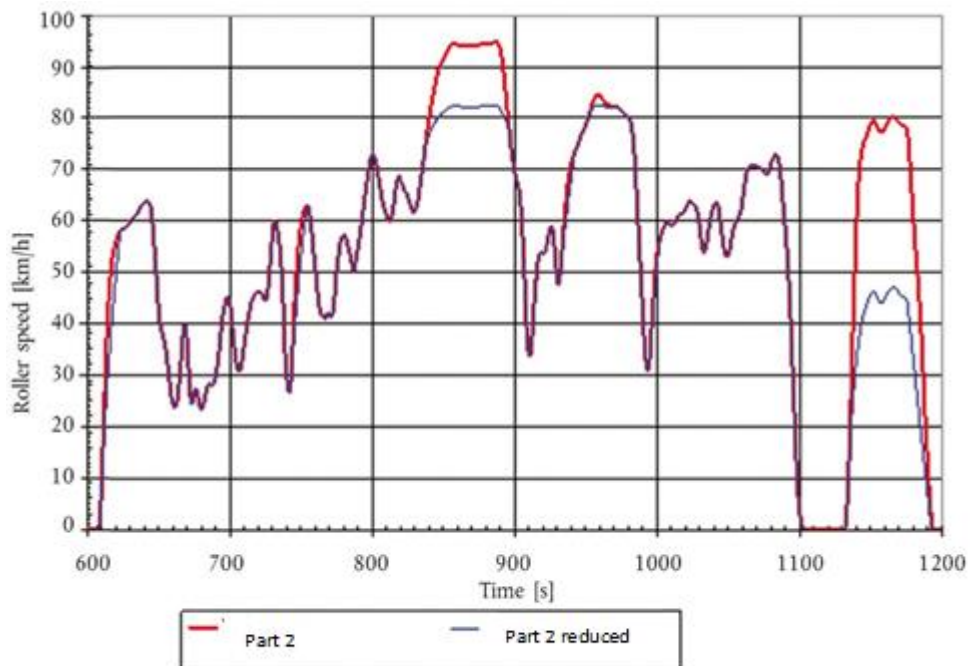

**Figure 3**

**WMTC STAGE 2, part 2**

- 3.1 The characteristic roller speed versus test time of WMTC STAGE 2, part 2 is set out in the following tables.

3.1.1

Table 9: WMTC STAGE 2, cycle part 2, reduced speed, 0 to 180 s																	
time in s	roller speed km/h	phase indicators				time in s	roller speed km/h	phase indicators				time in s	roller speed km/h	phase indicators			
		stop	acc	cruise	dec			stop	acc	cruise	dec			stop	acc	cruise	dec
0	0.0	X				61	23.7		X			121	46.2			X	
1	0.0	X				62	23.8		X			122	46.1			X	
2	0.0	X				63	25.0		X			123	45.7			X	
3	0.0	X				64	27.3		X			124	45.0			X	
4	0.0	X				65	30.4		X			125	44.3			X	
5	0.0	X				66	33.9		X			126	44.7		X		
6	0.0	X				67	37.3		X			127	46.8		X		
7	0.0	X				68	39.8				X	128	49.9		X		
8	0.0	X				69	39.5				X	129	52.8		X		
9	2.3		X			70	36.3				X	130	55.6		X		
10	7.3		X			71	31.4				X	131	58.2		X		
11	13.6		X			72	26.5				X	132	60.2				X
12	18.9		X			73	24.2				X	133	59.3				X
13	23.6		X			74	24.8				X	134	57.5				X
14	27.8		X			75	26.6				X	135	55.4				X
15	31.8		X			76	27.5				X	136	52.5				X
16	35.6		X			77	26.8				X	137	47.9				X
17	39.3		X			78	25.3				X	138	41.4				X
18	42.7		X			79	24.0				X	139	34.4				X
19	46.0		X			80	23.3				X	140	30.0				X
20	49.1		X			81	23.7				X	141	27.0				X
21	52.1		X			82	24.9				X	142	26.5		X		
22	54.9		X			83	26.4				X	143	28.7		X		
23	57.5		X			84	27.7				X	144	32.7		X		
24	58.4			X		85	28.3				X	145	36.5		X		
25	58.5			X		86	28.3				X	146	40.0		X		
26	58.5			X		87	28.1				X	147	43.5		X		
27	58.6			X		88	28.1		X			148	46.7		X		
28	58.9			X		89	28.6		X			149	49.8		X		
29	59.3			X		90	29.8		X			150	52.7		X		
30	59.8			X		91	31.6		X			151	55.5		X		
31	60.2			X		92	33.9		X			152	58.1		X		
32	60.5			X		93	36.5		X			153	60.6		X		
33	60.8			X		94	39.1		X			154	62.9		X		
34	61.1			X		95	41.5		X			155	62.9				X
35	61.5			X		96	43.3		X			156	61.7				X
36	62.0			X		97	44.5		X			157	59.4				X
37	62.5			X		98	45.1				X	158	56.6				X
38	63.0			X		99	45.1				X	159	53.7				X
39	63.4			X		100	43.9				X	160	50.7				X
40	63.7			X		101	41.4				X	161	47.7				X
41	63.8			X		102	38.4				X	162	45.0				X
42	63.9			X		103	35.5				X	163	43.1				X
43	63.8			X		104	32.9				X	164	41.9			X	
44	63.2				X	105	31.3				X	165	41.6			X	
45	61.7				X	106	30.7				X	166	41.3			X	
46	58.9				X	107	31.0			X		167	40.9			X	
47	55.2				X	108	32.2			X		168	41.8			X	
48	51.0				X	109	34.0			X		169	42.1			X	
49	46.7				X	110	36.0			X		170	41.8			X	
50	42.8				X	111	37.9			X		171	41.3			X	
51	40.2				X	112	39.9			X		172	41.5		X		
52	38.8				X	113	41.6			X		173	43.5		X		
53	37.9				X	114	43.1			X		174	46.5		X		
54	36.7				X	115	44.3			X		175	49.7		X		
55	35.1				X	116	45.0			X		176	52.6		X		
56	32.9				X	117	45.5			X		177	55.0		X		
57	30.4				X	118	45.8			X		178	56.5		X		
58	28.0				X	119	46.0			X		179	57.1		X		
59	25.9				X	120	46.1			X		180	57.3				X
60	24.4				X												

3.1.2

**Table 10: WMTC STAGE 2, cycle part 2, reduced speed, 181 to 360 s**

time in s	roller speed km/h	phase indicators				time in s	roller speed km/h	phase indicators				time in s	roller speed km/h	phase indicators			
		stop	acc	cruise	dec			stop	acc	cruise	dec			stop	acc	cruise	dec
181	57.0				X	241	77.5		X			301	68.3				X
182	56.3				X	242	78.1			X		302	67.3				X
183	55.2				X	243	78.6			X		303	66.1				X
184	53.9				X	244	79.0			X		304	63.9				X
185	52.6				X	245	79.4			X		305	60.2				X
186	51.4				X	246	79.7			X		306	54.9				X
187	50.1		X			247	80.1			X		307	48.1				X
188	51.5		X			248	80.7			X		308	40.9				X
189	53.1		X			249	80.8			X		309	36.0				X
190	54.8		X			250	81.0			X		310	33.9				X
191	56.6		X			251	81.2			X		311	33.9	X			
192	58.5		X			252	81.6			X		312	36.5	X			
193	60.6		X			253	81.9			X		313	40.1	X			
194	62.8		X			254	82.1			X		314	43.5	X			
195	64.9		X			255	82.1			X		315	46.8	X			
196	67.0		X			256	82.3			X		316	49.8	X			
197	69.1		X			257	82.4			X		317	52.8	X			
198	70.9		X			258	82.4			X		318	53.9	X			
199	72.2		X			259	82.3			X		319	53.9	X			
200	72.8				X	260	82.3			X		320	53.7	X			
201	72.8				X	261	82.2			X		321	53.7	X			
202	71.9				X	262	82.2			X		322	54.3	X			
203	70.5				X	263	82.1			X		323	55.4	X			
204	68.8				X	264	82.1			X		324	56.8	X			
205	67.1				X	265	82.0			X		325	58.1	X			
206	65.4				X	266	82.0			X		326	58.9				X
207	63.9				X	267	81.9			X		327	58.2				X
208	62.8				X	268	81.9			X		328	55.8				X
209	61.8				X	269	81.9			X		329	52.6				X
210	61.0				X	270	81.9			X		330	49.2				X
211	60.4				X	271	81.9			X		331	47.6	X			
212	60.0		X			272	82.0			X		332	48.4	X			
213	60.2		X			273	82.0			X		333	51.4	X			
214	61.4		X			274	82.1			X		334	54.2	X			
215	63.3		X			275	82.2			X		335	56.9	X			
216	65.5		X			276	82.3			X		336	59.4	X			
217	67.4		X			277	82.4			X		337	61.8	X			
218	68.5		X			278	82.5			X		338	64.1	X			
219	68.7				X	279	82.5			X		339	66.2	X			
220	68.1				X	280	82.5			X		340	68.2	X			
221	67.3				X	281	82.5			X		341	70.2	X			
222	66.5				X	282	82.4			X		342	72.0	X			
223	65.9				X	283	82.4			X		343	73.7	X			
224	65.5				X	284	82.4			X		344	74.4	X			
225	64.9				X	285	82.5			X		345	75.1	X			
226	64.1				X	286	82.5			X		346	75.8	X			
227	63.0				X	287	82.5			X		347	76.5	X			
228	62.1				X	288	82.4			X		348	77.2	X			
229	61.6		X			289	82.3			X		349	77.8	X			
230	61.7		X			290	81.6			X		350	78.5	X			
231	62.3		X			291	81.3			X		351	79.2	X			
232	63.5		X			292	80.3			X		352	80.0	X			
233	65.3		X			293	79.9			X		353	81.0			X	
234	67.3		X			294	79.2			X		354	81.2			X	
235	69.2		X			295	79.2			X		355	81.8			X	
236	71.1		X			296	78.4			X		356	82.2			X	
237	73.0		X			297	75.7			X		357	82.2			X	
238	74.8		X			298	73.2			X		358	82.4			X	
239	75.7		X			299	71.1			X		359	82.5			X	
240	76.7		X			300	69.5			X		360	82.5			X	

3.1.3

**Table 11: WMTC STAGE 2, cycle part 2, reduced speed, 360 s to 540s**

time in s	roller speed km/h	phase indicators				time in s	roller speed km/h	phase indicators				time in s	roller speed km/h	phase indicators			
		stop	acc	cruise	dec			stop	acc	cruise	dec			stop	acc	cruise	dec
361	82.5			X		421	63.1			X		481	72.0			X	
362	82.5			X		422	63.6			X		482	72.6			X	
363	82.3			X		423	63.9			X		483	72.8			X	
364	82.1			X		424	63.8			X		484	72.7			X	
365	82.1			X		425	63.6			X		485	72.0				X
366	82.1			X		426	63.3			X		486	70.4				X
367	82.1			X		427	62.8			X		487	67.7				X
368	82.1			X		428	61.9			X		488	64.4				X
369	82.1			X		429	60.5			X		489	61.0				X
370	82.1			X		430	58.6			X		490	57.6				X
371	82.1			X		431	56.5			X		491	54.0				X
372	82.1			X		432	54.6			X		492	49.7				X
373	81.9			X		433	53.8			X		493	44.4				X
374	81.6			X		434	54.5			X		494	38.2				X
375	81.3			X		435	56.1			X		495	31.2				X
376	81.1			X		436	57.9			X		496	24.0				X
377	80.8			X		437	59.7			X		497	16.8				X
378	80.6			X		438	61.2			X		498	10.4				X
379	80.4			X		439	62.3			X		499	5.7				X
380	80.1			X		440	63.1			X		500	2.8				X
381	79.7				X	441	63.6			X		501	1.6				X
382	78.6				X	442	63.5			X		502	0.3				X
383	76.8				X	443	62.7			X		503	0.0	X			
384	73.7				X	444	60.9			X		504	0.0	X			
385	69.4				X	445	58.7			X		505	0.0	X			
386	64.0				X	446	56.4			X		506	0.0	X			
387	58.6				X	447	54.5			X		507	0.0	X			
388	53.2				X	448	53.3			X		508	0.0	X			
389	47.8				X	449	53.0			X		509	0.0	X			
390	42.4				X	450	53.5			X		510	0.0	X			
391	37.0				X	451	54.6			X		511	0.0	X			
392	33.0				X	452	56.1			X		512	0.0	X			
393	30.9				X	453	57.6			X		513	0.0	X			
394	30.9		X			454	58.9			X		514	0.0	X			
395	33.5		X			455	59.8			X		515	0.0	X			
396	37.2		X			456	60.3			X		516	0.0	X			
397	40.8		X			457	60.7			X		517	0.0	X			
398	44.2		X			458	61.3			X		518	0.0	X			
399	47.4		X			459	62.4			X		519	0.0	X			
400	50.4		X			460	64.1			X		520	0.0	X			
401	53.3		X			461	66.2			X		521	0.0	X			
402	56.1		X			462	68.1			X		522	0.0	X			
403	57.3		X			463	69.7			X		523	0.0	X			
404	58.1		X			464	70.4			X		524	0.0	X			
405	58.8		X			465	70.7			X		525	0.0	X			
406	59.4		X			466	70.7			X		526	0.0	X			
407	59.8			X		467	70.7			X		527	0.0	X			
408	59.7			X		468	70.7			X		528	0.0	X			
409	59.4			X		469	70.6			X		529	0.0	X			
410	59.2			X		470	70.5			X		530	0.0	X			
411	59.2			X		471	70.4			X		531	0.0	X			
412	59.6			X		472	70.2			X		532	0.0	X			
413	60.0			X		473	70.1			X		533	2.3		X		
414	60.5			X		474	69.8			X		534	7.2		X		
415	61.0			X		475	69.5			X		535	13.5		X		
416	61.2			X		476	69.1			X		536	18.7		X		
417	61.3			X		477	69.1			X		537	22.9		X		
418	61.4			X		478	69.5			X		538	26.7		X		
419	61.7			X		479	70.3			X		539	30.0		X		
420	62.3			X		480	71.2			X		540	32.8		X		

3.1.4.

**Table 12 : WMTC STAGE 2, cycle part 2, reduced speed, 541 to 600 s**

time in s	roller speed in km/h	phase indicators			
		stop	Acc	cruise	Dec
541	35.2		X		
542	37.3		X		
543	39.1		X		
544	40.8		X		
545	41.8		X		
546	42.5		X		
547	43.3		X		
548	44.1		X		
549	45.0		X		
550	45.7		X		
551	46.2			X	
552	46.3			X	
553	46.1			X	
554	45.6			X	
555	44.9			X	
556	44.4			X	
557	44.0			X	
558	44.0			X	
559	44.3			X	
560	44.8			X	
561	45.3			X	
562	45.9			X	
563	46.5			X	
564	46.8			X	
565	47.1			X	
566	47.1			X	
567	47.0			X	
568	46.7			X	
569	46.3			X	
570	45.9			X	
571	45.6			X	
572	45.4			X	
573	45.2			X	
574	45.1			X	
575	44.8				X
576	43.5				X
577	40.9				X
578	38.2				X
579	35.6				X
580	33.0				X
581	30.4				X
582	27.7				X
583	25.1				X
584	22.5				X
585	19.8				X
586	17.2				X
587	14.6				X
588	12.0				X
589	9.3				X
590	6.7				X
591	4.1				X
592	1.5				X
593	0.0	X			
594	0.0	X			
595	0.0	X			
596	0.0	X			
597	0.0	X			
598	0.0	X			
599	0.0	X			
600	0.0	X			



3.1.5

**Table 13: WMTC STAGE 2, cycle part 2, 0 to 180 s**

time in s	roller speed km/h	phase indicators				time in s	roller speed km/h	phase indicators				time in s	roller speed km/h	phase indicators			
		stop	acc	cruise	dec			stop	acc	cruise	dec			stop	acc	cruise	dec
0	0.0	X				61	23.7		X			121	46.2			X	
1	0.0	X				62	23.8		X			122	46.1			X	
2	0.0	X				63	25.0		X			123	45.7			X	
3	0.0	X				64	27.3		X			124	45.0			X	
4	0.0	X				65	30.4		X			125	44.3			X	
5	0.0	X				66	33.9		X			126	44.7		X		
6	0.0	X				67	37.3		X			127	46.8		X		
7	0.0	X				68	39.8		X			128	50.1		X		
8	0.0	X				69	39.5				X	129	53.6		X		
9	2.3		X			70	36.3				X	130	56.9		X		
10	7.3		X			71	31.4				X	131	59.4		X		
11	15.2		X			72	26.5				X	132	60.2				X
12	23.9		X			73	24.2				X	133	59.3				X
13	32.5		X			74	24.8				X	134	57.5				X
14	39.2		X			75	26.6				X	135	55.4				X
15	44.1		X			76	27.5				X	136	52.5				X
16	48.1		X			77	26.8				X	137	47.9				X
17	51.2		X			78	25.3				X	138	41.4				X
18	53.3		X			79	24.0				X	139	34.4				X
19	54.5		X			80	23.3			X		140	30.0				X
20	55.7		X			81	23.7			X		141	27.0				X
21	56.9			X		82	24.9			X		142	26.5		X		
22	57.5			X		83	26.4			X		143	28.7		X		
23	58.0			X		84	27.7			X		144	33.8		X		
24	58.4			X		85	28.3			X		145	40.3		X		
25	58.5			X		86	28.3			X		146	46.6		X		
26	58.5			X		87	28.1			X		147	50.4		X		
27	58.6			X		88	28.1			X		148	54.0		X		
28	58.9			X		89	28.6			X		149	56.9		X		
29	59.3			X		90	29.8			X		150	59.1		X		
30	59.8			X		91	31.6			X		151	60.6		X		
31	60.2			X		92	33.9			X		152	61.7		X		
32	60.5			X		93	36.5			X		153	62.6		X		
33	60.8			X		94	39.1			X		154	63.1				X
34	61.1			X		95	41.5			X		155	62.9				X
35	61.5			X		96	43.3			X		156	61.7				X
36	62.0			X		97	44.5			X		157	59.4				X
37	62.5			X		98	45.1			X		158	56.6				X
38	63.0			X		99	45.1			X		159	53.7				X
39	63.4			X		100	43.9			X		160	50.7				X
40	63.7			X		101	41.4			X		161	47.7				X
41	63.8			X		102	38.4			X		162	45.0				X
42	63.9			X		103	35.5			X		163	43.1				X
43	63.8			X		104	32.9			X		164	41.9			X	
44	63.2				X	105	31.3			X		165	41.6			X	
45	61.7				X	106	30.7			X		166	41.3			X	
46	58.9				X	107	31.0			X		167	40.9			X	
47	55.2				X	108	32.2			X		168	41.8			X	
48	51.0				X	109	34.0			X		169	42.1			X	
49	46.7				X	110	36.0			X		170	41.8			X	
50	42.8				X	111	37.9			X		171	41.3			X	
51	40.2				X	112	39.9			X		172	41.5		X		
52	38.8				X	113	41.6			X		173	43.5		X		
53	37.9				X	114	43.1			X		174	46.5		X		
54	36.7				X	115	44.3			X		175	49.7		X		
55	35.1				X	116	45.0			X		176	52.6		X		
56	32.9				X	117	45.5			X		177	55.0		X		
57	30.4				X	118	45.8			X		178	56.5		X		
58	28.0				X	119	46.0			X		179	57.1		X		
59	25.9				X	120	46.1			X		180	57.3				X
60	24.4				X												

3.1.6

Table 14 : WMTC STAGE 2, cycle part 2, 181 to 360 s																		
time in s	roller speed km/h	phase indicators				time in s	roller speed km/h	phase indicators				time in s	roller speed km/h	phase indicators				
		stop	acc	cruise	dec			stop	acc	cruise	dec			stop	acc	cruise	dec	
181	57.0				X	241	81.5		X			301	68.3					X
182	56.3				X	242	83.1		X			302	67.3					X
183	55.2				X	243	84.6		X			303	66.1					X
184	53.9				X	244	86.0		X			304	63.9					X
185	52.6				X	245	87.4		X			305	60.2					X
186	51.4				X	246	88.7		X			306	54.9					X
187	50.1		X			247	89.6		X			307	48.1					X
188	51.5		X			248	90.2		X			308	40.9					X
189	53.1		X			249	90.7		X			309	36.0					X
190	54.8		X			250	91.2		X			310	33.9					X
191	56.6		X			251	91.8		X			311	33.9	X				
192	58.5		X			252	92.4		X			312	36.5	X				
193	60.6		X			253	93.0		X			313	41.0	X				
194	62.8		X			254	93.6		X			314	45.3	X				
195	64.9		X			255	94.1			X		315	49.2	X				
196	67.0		X			256	94.3			X		316	51.5	X				
197	69.1		X			257	94.4			X		317	53.2	X				
198	70.9		X			258	94.4			X		318	53.9	X				
199	72.2		X			259	94.3		X			319	53.9	X				
200	72.8				X	260	94.3			X		320	53.7	X				
201	72.8				X	261	94.2			X		321	53.7	X				
202	71.9				X	262	94.2			X		322	54.3	X				
203	70.5				X	263	94.2			X		323	55.4	X				
204	68.8				X	264	94.1			X		324	56.8	X				
205	67.1				X	265	94.0			X		325	58.1	X				
206	65.4				X	266	94.0			X		326	58.9					X
207	63.9				X	267	93.9			X		327	58.2					X
208	62.8				X	268	93.9			X		328	55.8					X
209	61.8				X	269	93.9		X			329	52.6					X
210	61.0				X	270	93.9		X			330	49.2					X
211	60.4				X	271	93.9		X			331	47.6	X				
212	60.0				X	272	94.0			X		332	48.4	X				
213	60.2			X		273	94.0			X		333	51.8	X				
214	61.4			X		274	94.1			X		334	55.7	X				
215	63.3			X		275	94.2			X		335	59.6	X				
216	65.5			X		276	94.3			X		336	63.0	X				
217	67.4			X		277	94.4			X		337	65.9	X				
218	68.5			X		278	94.5			X		338	68.1	X				
219	68.7				X	279	94.5		X			339	69.8	X				
220	68.1				X	280	94.5		X			340	71.1	X				
221	67.3				X	281	94.5		X			341	72.1	X				
222	66.5				X	282	94.4		X			342	72.9	X				
223	65.9				X	283	94.5		X			343	73.7	X				
224	65.5				X	284	94.6		X			344	74.4	X				
225	64.9				X	285	94.7		X			345	75.1	X				
226	64.1				X	286	94.8		X			346	75.8	X				
227	63.0				X	287	94.9		X			347	76.5	X				
228	62.1				X	288	94.8		X			348	77.2	X				
229	61.6		X			289	94.3			X		349	77.8	X				
230	61.7		X			290	93.3			X		350	78.5	X				
231	62.3		X			291	91.8			X		351	79.2	X				
232	63.5		X			292	89.6			X		352	80.0	X				
233	65.3		X			293	87.0			X		353	81.0	X				
234	67.3		X			294	84.1			X		354	82.0	X				
235	69.3		X			295	81.2			X		355	83.0	X				
236	71.4		X			296	78.4			X		356	83.7	X				
237	73.5		X			297	75.7			X		357	84.2				X	
238	75.6		X			298	73.2			X		358	84.4				X	
239	77.7		X			299	71.1			X		359	84.5				X	
240	79.7		X			300	69.5			X		360	84.4				X	

3.1.7

Table 15 : WMTC STAGE 2, cycle part 2, 361 to 540 s																	
time in s	roller speed km/h	phase indicators				time in s	roller speed km/h	phase indicators				time in s	roller speed km/h	phase indicators			
		stop	acc	cruise	dec			stop	acc	cruise	dec			stop	acc	cruise	dec
361	84.1			X		421	63.1			X		481	72.0			X	
362	83.7			X		422	63.6			X		482	72.6			X	
363	83.2			X		423	63.9			X		483	72.8			X	
364	82.8			X		424	63.8			X		484	72.7			X	
365	82.6			X		425	63.6			X		485	72.0				X
366	82.5			X		426	63.3			X		486	70.4				X
367	82.4			X		427	62.8			X		487	67.7				X
368	82.3			X		428	61.9			X		488	64.4				X
369	82.2			X		429	60.5			X		489	61.0				X
370	82.2			X		430	58.6			X		490	57.6				X
371	82.2			X		431	56.5			X		491	54.0				X
372	82.1			X		432	54.6			X		492	49.7				X
373	81.9			X		433	53.8			X		493	44.4				X
374	81.6			X		434	54.5			X		494	38.2				X
375	81.3			X		435	56.1			X		495	31.2				X
376	81.1			X		436	57.9			X		496	24.0				X
377	80.8			X		437	59.7			X		497	16.8				X
378	80.6			X		438	61.2			X		498	10.4				X
379	80.4			X		439	62.3			X		499	5.7				X
380	80.1			X		440	63.1			X		500	2.8				X
381	79.7				X	441	63.6			X		501	1.6				X
382	78.6				X	442	63.5			X		502	0.3				X
383	76.8				X	443	62.7			X		503	0.0	X			
384	73.7				X	444	60.9			X		504	0.0	X			
385	69.4				X	445	58.7			X		505	0.0	X			
386	64.0				X	446	56.4			X		506	0.0	X			
387	58.6				X	447	54.5			X		507	0.0	X			
388	53.2				X	448	53.3			X		508	0.0	X			
389	47.8				X	449	53.0			X		509	0.0	X			
390	42.4				X	450	53.5			X		510	0.0	X			
391	37.0				X	451	54.6			X		511	0.0	X			
392	33.0				X	452	56.1			X		512	0.0	X			
393	30.9				X	453	57.6			X		513	0.0	X			
394	30.9		X			454	58.9			X		514	0.0	X			
395	33.5		X			455	59.8			X		515	0.0	X			
396	38.0		X			456	60.3			X		516	0.0	X			
397	42.5		X			457	60.7			X		517	0.0	X			
398	47.0		X			458	61.3			X		518	0.0	X			
399	51.0		X			459	62.4			X		519	0.0	X			
400	53.5		X			460	64.1			X		520	0.0	X			
401	55.1		X			461	66.2			X		521	0.0	X			
402	56.4		X			462	68.1			X		522	0.0	X			
403	57.3		X			463	69.7			X		523	0.0	X			
404	58.1		X			464	70.4			X		524	0.0	X			
405	58.8		X			465	70.7			X		525	0.0	X			
406	59.4		X			466	70.7			X		526	0.0	X			
407	59.8			X		467	70.7			X		527	0.0	X			
408	59.7			X		468	70.7			X		528	0.0	X			
409	59.4			X		469	70.6			X		529	0.0	X			
410	59.2			X		470	70.5			X		530	0.0	X			
411	59.2			X		471	70.4			X		531	0.0	X			
412	59.6			X		472	70.2			X		532	0.0	X			
413	60.0			X		473	70.1			X		533	2.3		X		
414	60.5			X		474	69.8			X		534	7.2		X		
415	61.0			X		475	69.5			X		535	14.6		X		
416	61.2			X		476	69.1			X		536	23.5		X		
417	61.3			X		477	69.1			X		537	33.0		X		
418	61.4			X		478	69.5			X		538	42.7		X		
419	61.7			X		479	70.3			X		539	51.8		X		
420	62.3			X		480	71.2			X		540	59.4		X		

3.1.8.

Table 16 : WMTC STAGE 2, cycle part 2, 541 to 600 s					
time in s	roller speed in km/h	phase indicators			
		stop	Acc	cruise	Dec
541	65.3				
542	69.6		X		
543	72.3		X		
544	73.9		X		
545	75.0		X		
546	75.7		X		
547	76.5		X		
548	77.3		X		
549	78.2		X		
550	78.9		X		
551	79.4			X	
552	79.6			X	
553	79.3			X	
554	78.8			X	
555	78.1			X	
556	77.5			X	
557	77.2			X	
558	77.2			X	
559	77.5			X	
560	77.9			X	
561	78.5			X	
562	79.1			X	
563	79.6			X	
564	80.0			X	
565	80.2			X	
566	80.3			X	
567	80.1			X	
568	79.8			X	
569	79.5			X	
570	79.1			X	
571	78.8			X	
572	78.6			X	
573	78.4			X	
574	78.3			X	
575	78.0				X
576	76.7				X
577	73.7				X
578	69.5				X
579	64.8				X
580	60.3				X
581	56.2				X
582	52.5				X
583	49.0				X
584	45.2				X
585	40.8				X
586	35.4				X
587	29.4				X
588	23.4				X
589	17.7				X
590	12.6				X
591	8.0				X
592	4.1				X
593	1.3				X
594	0.0	X			
595	0.0	X			
596	0.0	X			
597	0.0	X			
598	0.0	X			
598	0.0	x			
600	0.0				

4. WMTC STAGE 2, Part 3

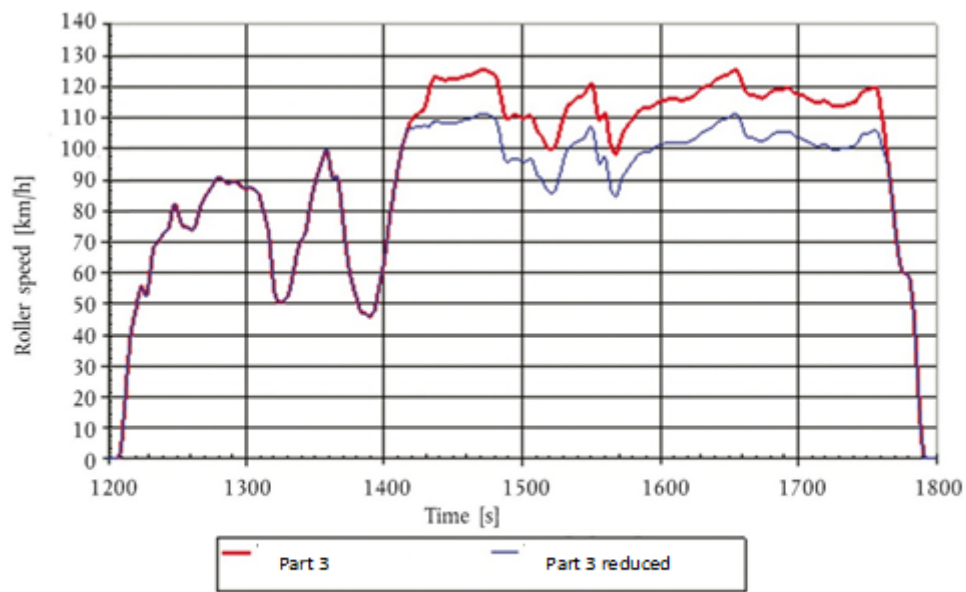

Figure 4:  
WMTC STAGE 2, part 3

4.1 The characteristic roller speed versus test time of WMTC STAGE 2, part 3 is set out in the following tables.

## 4.1.1

time in s	roller speed km/h	phase indicators				time in s	roller speed km/h	phase indicators				time in s	roller speed km/h	phase indicators				
		stop	acc	cruise	dec			stop	acc	cruise	dec			stop	acc	cruise	dec	
0	0.0	X				61	73.9				X	121	53.0					X
1	0.0	X				62	74.1		X			122	51.6					X
2	0.0	X				63	75.1		X			123	50.9					X
3	0.0	X				64	76.8		X			124	50.5					X
4	0.0	X				65	78.7		X			125	50.2					X
5	0.0	X				66	80.4		X			126	50.3		X			
6	0.0	X				67	81.7		X			127	50.6		X			
7	0.0	X				68	82.6		X			128	51.2		X			
8	0.9		X			69	83.5		X			129	51.8		X			
9	3.2		X			70	84.4		X			130	52.5		X			
10	7.3		X			71	85.1		X			131	53.4		X			
11	12.4		X			72	85.7		X			132	54.9		X			
12	17.9		X			73	86.3		X			133	57.0		X			
13	23.5		X			74	87.0		X			134	59.4		X			
14	29.1		X			75	87.9		X			135	61.9		X			
15	34.3		X			76	88.8		X			136	64.3		X			
16	38.6		X			77	89.7		X			137	66.4		X			
17	41.6		X			78	90.3			X		138	68.1		X			
18	43.9		X			79	90.6			X		139	69.6		X			
19	45.9		X			80	90.6			X		140	70.7		X			
20	48.1		X			81	90.5			X		141	71.4		X			
21	50.3		X			82	90.4			X		142	71.8		X			
22	52.6		X			83	90.1			X		143	72.8		X			
23	54.8		X			84	89.7			X		144	75.0		X			
24	55.8		X			85	89.3			X		145	77.8		X			
25	55.2		X			86	89.0			X		146	80.7		X			
26	53.9		X			87	88.8			X		147	83.3		X			
27	52.7		X			88	88.9			X		148	85.4		X			
28	52.8		X			89	89.1			X		149	87.3		X			
29	55.0		X			90	89.3			X		150	89.1		X			
30	58.5		X			91	89.4			X		151	90.6		X			
31	62.3		X			92	89.4			X		152	91.9		X			
32	65.7		X			93	89.2			X		153	93.2		X			
33	68.1		X			94	88.9			X		154	94.6		X			
34	69.1		X			95	88.5			X		155	96.0		X			
35	69.5		X			96	88.0			X		156	97.5		X			
36	69.9		X			97	87.5			X		157	99.0		X			
37	70.6		X			98	87.2			X		158	99.8					X
38	71.3		X			99	87.1			X		159	99.0					X
39	72.2		X			100	87.2			X		160	96.7					X
40	72.8		X			101	87.3			X		161	93.7					X
41	73.2		X			102	87.4			X		162	91.3					X
42	73.4		X			103	87.5			X		163	90.4					X
43	73.8		X			104	87.4			X		164	90.6					X
44	74.8		X			105	87.1			X		165	91.1					X
45	76.7		X			106	86.8			X		166	90.9					X
46	79.1		X			107	86.4			X		167	89.0					X
47	81.1		X			108	85.9			X		168	85.6					X
48	82.1				X	109	85.2				X	169	81.6					X
49	81.7				X	110	84.0				X	170	77.6					X
50	80.3				X	111	82.2				X	171	73.6					X
51	78.8				X	112	80.3				X	172	69.7					X
52	77.3				X	113	78.6				X	173	66.0					X
53	75.9				X	114	77.2				X	174	62.7					X
54	75.0				X	115	75.9				X	175	60.0					X
55	74.7				X	116	73.8				X	176	58.0					X
56	74.7				X	117	70.4				X	177	56.4					X
57	74.7				X	118	65.7				X	178	54.8					X
58	74.6				X	119	60.5				X	179	53.3					X
59	74.4				X	120	55.9				X	180	51.7					X
60	74.1				X													

## 4.1.2

Table 18 : WMTC STAGE 2, cycle part 3, reduced speed, 181 to 360 s																	
time in s	roller speed km/h	phase indicators				time in s	roller speed km/h	phase indicators				time in s	roller speed km/h	phase indicators			
		stop	acc	cruise	dec			stop	acc	cruise	dec			stop	acc	cruise	dec
181	50.2				X	241	108.4			X		301	95.8			X	
182	48.7				X	242	108.3			X		302	95.9			X	
183	47.2			X		243	108.2			X		303	96.2			X	
184	47.1			X		244	108.2			X		304	96.4			X	
185	47.0			X		245	108.2			X		305	96.7			X	
186	46.9			X		246	108.2			X		306	96.7			X	
187	46.6			X		247	108.3			X		307	96.3			X	
188	46.3			X		248	108.4			X		308	95.3				X
189	46.1			X		249	108.5			X		309	94.0				X
190	46.1		X			250	108.5			X		310	92.5				X
191	46.5		X			251	108.5			X		311	91.4				X
192	47.1		X			252	108.5			X		312	90.9				X
193	48.1		X			253	108.5			X		313	90.7				X
194	49.8		X			254	108.7			X		314	90.3				X
195	52.2		X			255	108.8			X		315	89.6				X
196	54.8		X			256	109.0			X		316	88.6				X
197	57.3		X			257	109.2			X		317	87.7				X
198	59.5		X			258	109.3			X		318	86.8				X
199	61.7		X			259	109.4			X		319	86.2				X
200	64.4		X			260	109.5			X		320	85.8				X
201	67.7		X			261	109.5			X		321	85.7				X
202	71.4		X			262	109.6			X		322	85.7				X
203	74.9		X			263	109.8			X		323	86.0			X	
204	78.2		X			264	110.0			X		324	86.7			X	
205	81.1		X			265	110.2			X		325	87.8			X	
206	83.9		X			266	110.5			X		326	89.2			X	
207	86.6		X			267	110.7			X		327	90.9			X	
208	89.1		X			268	111.0			X		328	92.6			X	
209	91.6		X			269	111.1			X		329	94.3			X	
210	94.0		X			270	111.2			X		330	95.9			X	
211	96.3		X			271	111.3			X		331	97.4			X	
212	98.4		X			272	111.3			X		332	98.7			X	
213	100.4		X			273	111.3			X		333	99.7			X	
214	102.1		X			274	111.2			X		334	100.3			X	
215	103.6		X			275	111.0			X		335	100.6			X	
216	104.9		X			276	110.8			X		336	101.0			X	
217	106.2			X		277	110.6			X		337	101.4			X	
218	106.5			X		278	110.4			X		338	101.8			X	
219	106.5			X		279	110.3			X		339	102.2			X	
220	106.6			X		280	109.9			X		340	102.5			X	
221	106.6			X		281	109.3				X	341	102.6			X	
222	107.0			X		282	108.1				X	342	102.7			X	
223	107.3			X		283	106.3				X	343	102.8			X	
224	107.3			X		284	104.0				X	344	103.0			X	
225	107.2			X		285	101.5				X	345	103.5			X	
226	107.2			X		286	99.2				X	346	104.3			X	
227	107.2			X		287	97.2				X	347	105.2			X	
228	107.3			X		288	96.1				X	348	106.1			X	
229	107.5			X		289	95.7			X		349	106.8			X	
230	107.3			X		290	95.8			X		350	107.1				X
231	107.3			X		291	96.1			X		351	106.7				X
232	107.3			X		292	96.4			X		352	105.0				X
233	107.3			X		293	96.7			X		353	102.3				X
234	108.0			X		294	96.9			X		354	99.1				X
235	108.2			X		295	96.9			X		355	96.3				X
236	108.9			X		296	96.8			X		356	95.0				X
237	109.0			X		297	96.7			X		357	95.4				X
238	108.9			X		298	96.4			X		358	96.4				X
239	108.8			X		299	96.1			X		359	97.3				X
240	108.6			X		300	95.9			X		360	97.5				X

4.1.3

Table 19 : WMTC STAGE 2, cycle part 3, reduced speed, 361 to 540 s																		
time in s	roller speed km/h	phase indicators				time in s	roller speed km/h	phase indicators				time in s	roller speed km/h	phase indicators				
		stop	acc	cruise	dec			stop	acc	cruise	dec			stop	acc	cruise	dec	
361	96.1				X	421	102.2			X		481	104.5				X	
362	93.4				X	422	102.4			X		482	104.8				X	
363	90.4				X	423	102.6			X		483	104.9				X	
364	87.8				X	424	102.8			X		484	105.1				X	
365	86.0				X	425	103.1			X		485	105.1				X	
366	85.1				X	426	103.4			X		486	105.2				X	
367	84.7				X	427	103.9			X		487	105.2				X	
368	84.2			X		428	104.4			X		488	105.2				X	
369	85.0			X		429	104.9			X		489	105.3				X	
370	86.5			X		430	105.2			X		490	105.3				X	
371	88.3			X		431	105.5			X		491	105.4				X	
372	89.9			X		432	105.7			X		492	105.5				X	
373	91.0			X		433	105.9			X		493	105.5				X	
374	91.8			X		434	106.1			X		494	105.3				X	
375	92.5			X		435	106.3			X		495	105.1				X	
376	93.1			X		436	106.5			X		496	104.7				X	
377	93.7			X		437	106.8			X		497	104.2				X	
378	94.4			X		438	107.1			X		498	103.9				X	
379	95.0			X		439	107.5			X		499	103.6				X	
380	95.6			X		440	108.0			X		500	103.5				X	
381	96.3			X		441	108.3			X		501	103.5				X	
382	96.9			X		442	108.6			X		502	103.4				X	
383	97.5			X		443	108.9			X		503	103.3				X	
384	98.0			X		444	109.1			X		504	103.0				X	
385	98.3			X		445	109.2			X		505	102.7				X	
386	98.6			X		446	109.4			X		506	102.4				X	
387	98.9			X		447	109.5			X		507	102.1				X	
388	99.1			X		448	109.7			X		508	101.9				X	
389	99.3			X		449	109.9			X		509	101.7				X	
390	99.3			X		450	110.2			X		510	101.5				X	
391	99.2			X		451	110.5			X		511	101.3				X	
392	99.2			X		452	110.8			X		512	101.2				X	
393	99.3			X		453	111.0			X		513	101.0				X	
394	99.5			X		454	111.2			X		514	100.9				X	
395	99.9			X		455	111.3			X		515	100.9				X	
396	100.3			X		456	111.1			X		516	101.0				X	
397	100.6			X		457	110.4			X		517	101.2				X	
398	100.9			X		458	109.3			X		518	101.3				X	
399	101.1			X		459	108.1			X		519	101.4				X	
400	101.3			X		460	106.8			X		520	101.4				X	
401	101.4			X		461	105.5			X		521	101.2				X	
402	101.5			X		462	104.4			X		522	100.8				X	
403	101.6			X		463	103.8			X		523	100.4				X	
404	101.8			X		464	103.6			X		524	99.9				X	
405	101.9			X		465	103.5			X		525	99.6				X	
406	102.0			X		466	103.5			X		526	99.5				X	
407	102.0			X		467	103.4			X		527	99.5				X	
408	102.0			X		468	103.3			X		528	99.6				X	
409	102.0			X		469	103.1			X		529	99.7				X	
410	101.9			X		470	102.9			X		530	99.8				X	
411	101.9			X		471	102.6			X		531	99.9				X	
412	101.9			X		472	102.5			X		532	100.0				X	
413	101.8			X		473	102.4			X		533	100.0				X	
414	101.8			X		474	102.4			X		534	100.1				X	
415	101.8			X		475	102.5			X		535	100.2				X	
416	101.8			X		476	102.7			X		536	100.4				X	
417	101.8			X		477	103.0			X		537	100.5				X	
418	101.8			X		478	103.3			X		538	100.6				X	
419	101.9			X		479	103.7			X		539	100.7				X	
420	102.0			X		480	104.1			X		540	100.8				X	



4.1.4.

<b>Table 20 : WMTC STAGE 2, cycle part 3, reduced speed, 541 to 600 s</b>					
time in s	roller speed in km/h	phase indicators			
		stop	Acc	cruise	Dec
541	101.0			X	
542	101.3			X	
543	102.0			X	
544	102.7			X	
545	103.5			X	
546	104.2			X	
547	104.6			X	
548	104.7			X	
549	104.8			X	
550	104.8			X	
551	104.9			X	
552	105.1			X	
553	105.4			X	
554	105.7			X	
555	105.9			X	
556	106.0			X	
557	105.7				X
558	105.4				X
559	103.9				X
560	102.2				X
561	100.5				X
562	99.2				X
563	98.0				X
564	96.4				X
565	94.8				X
566	92.8				X
567	88.9				X
568	84.9				X
569	80.6				X
570	76.3				X
571	72.3				X
572	68.7				X
573	65.5				X
574	63.0				X
575	61.2				X
576	60.5				X
577	60.0				X
578	59.7				X
579	59.4				X
580	59.4				X
581	58.0				X
582	55.0				X
583	51.0				X
584	46.0				X
585	38.8				X
586	31.6				X
587	24.4				X
588	17.2				X
589	10.0				X
590	5.0				X
591	2.0				X
592	0.0	X			
593	0.0	X			
594	0.0	X			
595	0.0	X			
596	0.0	X			
597	0.0	X			
598	0.0	X			
599	0.0	X			
600	0.0	X			

## 4.1.5

Table 21 : WMTC STAGE 2, cycle part 3, 0 to 180 s																		
time in s	roller speed km/h	phase indicators				time in s	roller speed km/h	phase indicators				time in s	roller speed km/h	phase indicators				
		stop	acc	cruise	dec			stop	acc	cruise	dec			stop	acc	cruise	dec	
0	0.0	X				61	73.9				X	121	53.0					X
1	0.0	X				62	74.1		X			122	51.6					X
2	0.0	X				63	75.1		X			123	50.9					X
3	0.0	X				64	76.8		X			124	50.5					X
4	0.0	X				65	78.7		X			125	50.2					X
5	0.0	X				66	80.4		X			126	50.3		X			
6	0.0	X				67	81.7		X			127	50.6		X			
7	0.0	X				68	82.6		X			128	51.2		X			
8	0.9		X			69	83.5		X			129	51.8		X			
9	3.2		X			70	84.4		X			130	52.5		X			
10	7.3		X			71	85.1		X			131	53.4		X			
11	12.4		X			72	85.7		X			132	54.9		X			
12	17.9		X			73	86.3		X			133	57.0		X			
13	23.5		X			74	87.0		X			134	59.4		X			
14	29.1		X			75	87.9		X			135	61.9		X			
15	34.3		X			76	88.8		X			136	64.3		X			
16	38.6		X			77	89.7		X			137	66.4		X			
17	41.6		X			78	90.3			X		138	68.1		X			
18	43.9		X			79	90.6			X		139	69.6		X			
19	45.9		X			80	90.6			X		140	70.7		X			
20	48.1		X			81	90.5			X		141	71.4		X			
21	50.3		X			82	90.4			X		142	71.8		X			
22	52.6		X			83	90.1			X		143	72.8		X			
23	54.8		X			84	89.7			X		144	75.0		X			
24	55.8		X			85	89.3			X		145	77.8		X			
25	55.2		X			86	89.0			X		146	80.7		X			
26	53.9		X			87	88.8			X		147	83.3		X			
27	52.7		X			88	88.9			X		148	85.4		X			
28	52.8		X			89	89.1			X		149	87.3		X			
29	55.0		X			90	89.3			X		150	89.1		X			
30	58.5		X			91	89.4			X		151	90.6		X			
31	62.3		X			92	89.4			X		152	91.9		X			
32	65.7		X			93	89.2			X		153	93.2		X			
33	68.1		X			94	88.9			X		154	94.6		X			
34	69.1		X			95	88.5			X		155	96.0		X			
35	69.5		X			96	88.0			X		156	97.5		X			
36	69.9		X			97	87.5			X		157	99.0		X			
37	70.6		X			98	87.2			X		158	99.8					X
38	71.3		X			99	87.1			X		159	99.0					X
39	72.2		X			100	87.2			X		160	96.7					X
40	72.8		X			101	87.3			X		161	93.7					X
41	73.2		X			102	87.4			X		162	91.3					X
42	73.4		X			103	87.5			X		163	90.4					X
43	73.8		X			104	87.4			X		164	90.6					X
44	74.8		X			105	87.1			X		165	91.1					X
45	76.7		X			106	86.8			X		166	90.9					X
46	79.1		X			107	86.4			X		167	89.0					X
47	81.1		X			108	85.9			X		168	85.6					X
48	82.1				X	109	85.2				X	169	81.6					X
49	81.7				X	110	84.0				X	170	77.6					X
50	80.3				X	111	82.2				X	171	73.6					X
51	78.8				X	112	80.3				X	172	69.7					X
52	77.3				X	113	78.6				X	173	66.0					X
53	75.9				X	114	77.2				X	174	62.7					X
54	75.0				X	115	75.9				X	175	60.0					X
55	74.7				X	116	73.8				X	176	58.0					X
56	74.7				X	117	70.4				X	177	56.4					X
57	74.7				X	118	65.7				X	178	54.8					X
58	74.6				X	119	60.5				X	179	53.3					X
59	74.4				X	120	55.9				X	180	51.7					X
60	74.1				X													

4.1.6

Table 22 : WMTC STAGE 2, cycle part 3, 181 to 360 s																		
time in s	roller speed km/h	phase indicators				time in s	roller speed km/h	phase indicators				time in s	roller speed km/h	phase indicators				
		stop	acc	cruise	dec			stop	acc	cruise	dec			stop	acc	cruise	dec	
181	50.2				X	241	122.4			X		301	109.8				X	
182	48.7				X	242	122.3			X		302	109.9				X	
183	47.2			X		243	122.2			X		303	110.2				X	
184	47.1			X		244	122.2			X		304	110.4				X	
185	47.0			X		245	122.2			X		305	110.7				X	
186	46.9			X		246	122.2			X		306	110.7				X	
187	46.6			X		247	122.3			X		307	110.3				X	
188	46.3			X		248	122.4			X		308	109.3					X
189	46.1			X		249	122.5			X		309	108.0					X
190	46.1		X			250	122.5			X		310	106.5					X
191	46.5		X			251	122.5			X		311	105.4					X
192	47.1		X			252	122.5			X		312	104.9					X
193	48.1		X			253	122.5			X		313	104.7					X
194	49.8		X			254	122.7			X		314	104.3					X
195	52.2		X			255	122.8			X		315	103.6					X
196	54.8		X			256	123.0			X		316	102.6					X
197	57.3		X			257	123.2			X		317	101.7					X
198	59.5		X			258	123.3			X		318	100.8					X
199	61.7		X			259	123.4			X		319	100.2					X
200	64.4		X			260	123.5			X		320	99.8					X
201	67.7		X			261	123.5			X		321	99.7					X
202	71.4		X			262	123.6			X		322	99.7					X
203	74.9		X			263	123.8			X		323	100.0				X	
204	78.2		X			264	124.0			X		324	100.7				X	
205	81.1		X			265	124.2			X		325	101.8				X	
206	83.9		X			266	124.5			X		326	103.2				X	
207	86.6		X			267	124.7			X		327	104.9				X	
208	89.1		X			268	125.0			X		328	106.6				X	
209	91.6		X			269	125.1			X		329	108.3				X	
210	94.0		X			270	125.2			X		330	109.9				X	
211	96.3		X			271	125.3			X		331	111.4				X	
212	98.4		X			272	125.3			X		332	112.7				X	
213	100.4		X			273	125.3			X		333	113.7				X	
214	102.1		X			274	125.2			X		334	114.3				X	
215	103.6		X			275	125.0			X		335	114.6				X	
216	104.9		X			276	124.8			X		336	115.0				X	
217	106.2		X			277	124.6			X		337	115.4				X	
218	107.5		X			278	124.4			X		338	115.8				X	
219	108.5		X			279	124.3			X		339	116.2				X	
220	109.3		X			280	123.9			X		340	116.5				X	
221	109.9		X			281	123.3				X	341	116.6				X	
222	110.5		X			282	122.1				X	342	116.7				X	
223	110.9		X			283	120.3				X	343	116.8				X	
224	111.2		X			284	118.0				X	344	117.0				X	
225	111.4		X			285	115.5				X	345	117.5				X	
226	111.7		X			286	113.2				X	346	118.3				X	
227	111.9		X			287	111.2				X	347	119.2				X	
228	112.3		X			288	110.1				X	348	120.1				X	
229	113.0		X			289	109.7			X		349	120.8				X	
230	114.1		X			290	109.8			X		350	121.1					X
231	115.7		X			291	110.1			X		351	120.7					X
232	117.5		X			292	110.4			X		352	119.0					X
233	119.3		X			293	110.7			X		353	116.3					X
234	121.0		X			294	110.9			X		354	113.1					X
235	122.2			X		295	110.9			X		355	110.3					X
236	122.9			X		296	110.8			X		356	109.0					X
237	123.0			X		297	110.7			X		357	109.4					X
238	122.9			X		298	110.4			X		358	110.4					X
239	122.8			X		299	110.1			X		359	111.3					X
240	122.6			X		300	109.9			X		360	111.5					X

4.1.7

Table 23: WMTC STAGE 2, cycle part 3, 361 to 540 s																		
time in s	roller speed km/h	phase indicators				time in s	roller speed km/h	phase indicators				time in s	roller speed km/h	phase indicators				
		stop	acc	cruise	dec			stop	acc	cruise	dec			stop	acc	cruise	dec	
361	110.1				X	421	116.2			X		481	118.5				X	
362	107.4				X	422	116.4			X		482	118.8				X	
363	104.4				X	423	116.6			X		483	118.9				X	
364	101.8				X	424	116.8			X		484	119.1				X	
365	100.0				X	425	117.1			X		485	119.1				X	
366	99.1				X	426	117.4			X		486	119.2				X	
367	98.7				X	427	117.9			X		487	119.2				X	
368	98.2			X		428	118.4			X		488	119.2				X	
369	99.0			X		429	118.9			X		489	119.3				X	
370	100.5			X		430	119.2			X		490	119.3				X	
371	102.3			X		431	119.5			X		491	119.4				X	
372	103.9			X		432	119.7			X		492	119.5				X	
373	105.0			X		433	119.9			X		493	119.5				X	
374	105.8			X		434	120.1			X		494	119.3				X	
375	106.5			X		435	120.3			X		495	119.1				X	
376	107.1			X		436	120.5			X		496	118.7				X	
377	107.7			X		437	120.8			X		497	118.2				X	
378	108.4			X		438	121.1			X		498	117.9				X	
379	109.0			X		439	121.5			X		499	117.6				X	
380	109.6			X		440	122.0			X		500	117.5				X	
381	110.3			X		441	122.3			X		501	117.5				X	
382	110.9			X		442	122.6			X		502	117.4				X	
383	111.5			X		443	122.9			X		503	117.3				X	
384	112.0			X		444	123.1			X		504	117.0				X	
385	112.3			X		445	123.2			X		505	116.7				X	
386	112.6			X		446	123.4			X		506	116.4				X	
387	112.9			X		447	123.5			X		507	116.1				X	
388	113.1			X		448	123.7			X		508	115.9				X	
389	113.3			X		449	123.9			X		509	115.7				X	
390	113.3			X		450	124.2			X		510	115.5				X	
391	113.2			X		451	124.5			X		511	115.3				X	
392	113.2			X		452	124.8			X		512	115.2				X	
393	113.3			X		453	125.0			X		513	115.0				X	
394	113.5			X		454	125.2			X		514	114.9				X	
395	113.9			X		455	125.3			X		515	114.9				X	
396	114.3			X		456	125.1			X		516	115.0				X	
397	114.6			X		457	124.4			X		517	115.2				X	
398	114.9			X		458	123.3			X		518	115.3				X	
399	115.1			X		459	122.1			X		519	115.4				X	
400	115.3			X		460	120.8			X		520	115.4				X	
401	115.4			X		461	119.5			X		521	115.2				X	
402	115.5			X		462	118.4			X		522	114.8				X	
403	115.6			X		463	117.8			X		523	114.4				X	
404	115.8			X		464	117.6			X		524	113.9				X	
405	115.9			X		465	117.5			X		525	113.6				X	
406	116.0			X		466	117.5			X		526	113.5				X	
407	116.0			X		467	117.4			X		527	113.5				X	
408	116.0			X		468	117.3			X		528	113.6				X	
409	116.0			X		469	117.1			X		529	113.7				X	
410	115.9			X		470	116.9			X		530	113.8				X	
411	115.9			X		471	116.6			X		531	113.9				X	
412	115.9			X		472	116.5			X		532	114.0				X	
413	115.8			X		473	116.4			X		533	114.0				X	
414	115.8			X		474	116.4			X		534	114.1				X	
415	115.8			X		475	116.5			X		535	114.2				X	
416	115.8			X		476	116.7			X		536	114.4				X	
417	115.8			X		477	117.0			X		537	114.5				X	
418	115.8			X		478	117.3			X		538	114.6				X	
419	115.9			X		479	117.7			X		539	114.7				X	
420	116.0			X		480	118.1			X		540	114.8				X	

4.1.8.

Table 24 : WMTC STAGE 2 cycle part 3, 541 to 600 s					
time in s	roller speed in km/h	phase indicators			
		stop	Acc	cruise	Dec
541	115.0			X	
542	115.3			X	
543	116.0			X	
544	116.7			X	
545	117.5			X	
546	118.2			X	
547	118.6			X	
548	118.7			X	
549	118.8			X	
550	118.8			X	
551	118.9			X	
552	119.1			X	
553	119.4			X	
554	119.7			X	
555	119.9			X	
556	120.0			X	
557	119.7				X
558	118.4				X
559	115.9				X
560	113.2				X
561	110.5				X
562	107.2				X
563	104.0				X
564	100.4				X
565	96.8				X
566	92.8				X
567	88.9				X
568	84.9				X
569	80.6				X
570	76.3				X
571	72.3				X
572	68.7				X
573	65.5				X
574	63.0				X
575	61.2				X
576	60.5				X
577	60.0				X
578	59.7				X
579	59.4				X
580	59.4				X
581	58.0				X
582	55.0				X
583	51.0				X
584	46.0				X
585	38.8				X
586	31.6				X
587	24.4				X
588	17.2				X
589	10.0				X
590	5.0				X
591	2.0				X
592	0.0	X			
593	0.0	X			
594	0.0	X			
595	0.0	X			
596	0.0	X			
597	0.0	X			
598	0.0	X			
599	0.0	X			
600	0.0	X			

## APPENDIX 7 TO CHAPTER 2

## ROAD TESTS OF L2-CATEGORY VEHICLES EQUIPPED WITH ONE WHEEL ON THE DRIVEN AXLE OR WITH TWINNED WHEELS FOR THE DETERMINATION OF TEST BENCH SETTINGS

**1.0 REQUIREMENTS FOR THE RIDER**

- 1.1 The rider shall wear a well-fitting (one-piece) suit or similar clothing and a protective helmet, eye protection, boots and gloves.
- 1.2 The rider, dressed and equipped as described in clause 1.1. of this Appendix, shall have a mass of  $75\text{kg} \pm 5\text{kg}$  and be  $1.75 \pm 0.05$  m tall.
- 1.3 The rider shall be seated on the seat provided, with his feet on the footrests and his arms extended normally. This position shall allow the rider to have proper control of the vehicle at all times during the tests.

**2.0 REQUIREMENT FOR THE ROAD AND AMBIENT CONDITIONS**

- 2.1 The test road shall be flat, level, straight and smoothly paved. The road surface shall be dry and free of obstacles or wind barriers that might impede the measurement of the running resistance. The slope of the surface shall not exceed 0.5 percent between any two points at least 2 m apart.
- 2.2 During data collecting periods, the wind shall be steady. The wind speed and the direction of the wind shall be measured continuously or with adequate frequency at a location where the wind force during coast-down is representative.
- 2.3 The ambient conditions shall be within the following limits:
- maximum wind speed: 3 m/s
  - maximum wind speed for gusts: 5 m/s
  - average wind speed, parallel: 3 m/s
  - average wind speed, perpendicular: 2 m/s
  - maximum relative humidity: 95 percent
  - air temperature: 278.2 K to 308.2 K
- 2.4 Standard ambient conditions shall be as follows:
- pressure,  $P_0$ : 100 kPa
  - temperature,  $T_0$ : 293.2 k
  - relative air density,  $d_0$ : 0.9197
  - air volumetric mass,  $\rho_0$ :  $1.189 \text{ kg/m}^3$
- 2.5 The relative air density when the vehicle is tested, calculated in accordance with the formula given in equation 1 of this chapter shall not differ by more than 7.5 percent from the air density under the standard conditions.

- 2.6 The relative air density,  $d_T$ , shall be calculated using the following formula:

Equation 1:

$$d_T = d_0 * \frac{P_T}{P_0} * \frac{T_0}{T_T}$$

where:

$d_0$  is the reference relative air density at reference conditions (1.189 kg/m<sup>3</sup>)

$p_T$  is the mean ambient pressure during the test, in kPa;

$p_0$  is the reference ambient pressure (101.3 kPa);

$T_T$  is the mean ambient temperature during test, in K;

$T_0$  is the reference ambient temperature 293.20K/20°C

### **3.0 CONDITION OF TEST VEHICLE**

#### **3.1 Running-in**

The test vehicle shall be in normal running order and adjustment after having been run in for at least 300 km. The tyres shall be run in at the same time as the vehicle or shall have a tread depth within 90 and 50 percent of the initial tread depth, the same to be declared by the manufacturer

#### **3.2 Checks**

The following checks shall be made in accordance with the manufacturer's specifications for the use considered: wheels, wheel rims, tyres (make, type and pressure), front axle geometry, brake adjustment (elimination of parasitic drag), lubrication of front and rear axles, adjustment of the suspension and vehicle ground clearance, etc. Check that during freewheeling, there is no electrical braking.

#### **3.3 Preparation for the test**

3.3.1 The test vehicle shall be loaded to its test mass including rider and measurement equipment, spread in a uniform way in the loading areas.

3.3.2 The windows of the vehicle shall be closed. Any covers for air conditioning systems, headlamps, etc. shall be closed.

3.3.3 The test vehicle shall be clean, properly maintained and used.

3.3.4 Immediately before the test, the vehicle shall be brought to the normal running temperature in an appropriate manner.

3.3.5 When installing the measuring instruments on the test vehicle, care shall be taken to minimize their effects on the distribution of the load across the wheels. When installing the speed sensor outside the test vehicle, care shall be taken to minimize the additional aerodynamic loss.

#### 4.0 SPECIFIED COAST-DOWN SPEEDS

4.1 The coast-down times must be measured between  $v_1$  and  $v_2$  as specified in Table 1 of this Appendix, depending on the vehicle class as defined in clause 4.3 of Appendix 7 to Chapter 2.

4.2

**Table 1**  
**Coast-down time measurement beginning speed and ending speed**  
**45 km/h < maximum design speed  $\leq$  130 km/h and > 130 km/h**

Specified target vehicle speed $v_1$ , km/h	$v_1$ in km/h	$v_2$ in km/h
120	130*/	110
100	110*/	90
80	90*/	70
60	70	50
40	45	35
20	25	15

4.3 When the running resistance is verified in accordance with clause 5.2.2.3.2 of Chapter 2, the test can be executed at  $v_j \pm 5$  km/h, provided that the coast-down time accuracy referred to in clause 4.5.7 of Chapter 2 is ensured

#### 5.0 MEASUREMENT OF COAST-DOWN TIME

5.1 After a warm-up period, the vehicle shall be accelerated to the coast-down starting speed, at which point the coast-down measurement procedure shall be started.

5.2 Since shifting the transmission to neutral can be dangerous and complicated by the construction of the vehicle, the coasting may be performed solely with the clutch disengaged. Vehicles that have no means of cutting the transmitted engine power off prior to coasting may be towed until they reach the coast-down starting speed. When the coast-down test is reproduced on the chassis dynamometer, the drive train and clutch shall be in the same condition as during the road test

5.3 The vehicle steering shall be altered as little as possible and the brakes shall not be operated until the end of the coast-down measurement period.

5.4 The first coast-down time  $\Delta t_{aj}$  measured in Seconds corresponding to the specified speed  $v_j$  shall be measured as the time taken for the vehicle to decelerate from  $v_j + \Delta v$  to  $v_j - \Delta v$ .



- 5.5 The procedure described in clauses 5.1 to 5.4 of this Appendix shall be repeated in the opposite direction to measure the second coast-down time  $\Delta t_{bi}$ .
- 5.6 The average  $\Delta t_i$  of the two coast-down times  $\Delta t_{ai}$  and  $\Delta t_{bi}$  shall be calculated using the following equation:

Equation 2

$$\Delta t_i = \frac{\Delta t_{ai} + \Delta t_{bi}}{2}$$

- 5.7 At least four (consecutive valid) tests shall be performed and the average coast-down time  $\Delta T_j$  calculated using the following equation:

Equation 3

$$\Delta t_j = \frac{1}{n} * \sum_{i=1}^n \Delta t_i$$

- 5.8 Tests shall be performed until the statistical accuracy P is equal to or less than 3 percent ( $P \leq 3$  percent). The statistical accuracy P (as a percentage) is calculated using the following equation:

Equation 4

$$P = \frac{t * s}{\sqrt{n}} * \frac{100}{\Delta t_j}$$

where:

t is the coefficient given in Table 2 of this Appendix;

s is the standard deviation given by the following formula:

Equation 5

$$s = \sqrt{\sum_{i=1}^n \frac{(\Delta t_i - \Delta t_j)^2}{n - 1}}$$

where:

n is the number of tests.

**Table 2 -  
Coefficients for statistical accuracy**

n	t	$\frac{t}{\sqrt{n}}$
4	3.2	1.6
5	2.8	1.25
6	2.6	1.06
7	2.5	0.94
8	2.4	0.85
9	2.3	0.77
10	2.3	0.73
11	2.2	0.66
12	2.2	0.64
13	2.2	0.61
14	2.2	0.59
15	2.2	0.57

- 5.9 In repeating the test, care shall be taken to start the coast-down after observing the same warm-up procedure and at the same coast-down starting speed.
- 5.10 The coast-down times for multiple specified speeds may be measured in a continuous coast-down. In this case, the coast-down shall be repeated after observing the same warm-up procedure and at the same coast-down starting speed.
- 5.11 The coast-down time shall be recorded. A specimen record form is given in the Regulation for administrative requirements.

## **6.0 DATA PROCESSING**

### **6.1 Calculation of running resistance force**

- 6.1.1 The running resistance force  $F_j$ , in Newton, at the specified speed  $v_j$  shall be calculated using the following equation:

Equation 6

$$F_j = \frac{1}{3.6} * m_{ref} * \frac{2 * \Delta v}{\Delta t}$$

where:

$m_{ref}$  = reference mass (kg);

$\Delta v$  = vehicle speed deviation (km/h);

$\Delta t$  = calculated coast down time difference (s)

6.1.2 The running resistance force  $F_j$  shall be corrected in accordance with clause 6.2 of this Appendix.

**6.2 Running resistance curve fitting**

The running resistance force,  $F$ , shall be calculated as follows:

6.2.1 The following equation shall be fitted to the data set of  $F_j$  and  $v_j$  obtained in clauses 4 and 6.1 of this Appendix. respectively by least squares statistical regression analysis to determine the coefficients  $f_0$  and  $f_2$ ,

Equation 7

$$F = f_0 + f_2 * v^2$$

6.2.2 The coefficients  $f_0$  and  $f_2$  thus determined shall be corrected to the standard ambient conditions using the following equations:

Equation 8

$$f_0^* = f_0 = [1 + K_0(T_T - T_0)]$$

Equation 9

$$f_2^* = f_2 * \frac{T_T}{T_0} * \frac{p_0}{p_T}$$

$K_0$  shall be determined on the basis of the empirical data for the particular vehicle and tyre tests or shall be assumed as follows, if the information is not available:

$$K_0 = 6 * 10^{-3} \text{ K}^{-1}$$

**6.3 Target running resistance force  $F^*$  for chassis dynamometer setting**

The target running resistance force  $F^*(v_0)$  on the chassis dynamometer at the reference vehicle speed  $v_0$ , in Newton, is determined using the following equation:

Equation 10

$$F^*(v_0) = f_0^* + f_2^* * v_0^2$$

**APPENDIX 8 TO CHAPTER 2**  
**EXPLANATORY NOTE ON THE GEARSHIFT PROCEDURE FOR A**  
**TYPE I TEST**

**0.0 INTRODUCTION**

This explanatory note explains matters specified or described in this Part, including its Chapter or Appendices, and matters related thereto with regard to the gearshift procedure.

**1.0 APPROACH**

1.1 The development of the gearshift procedure was based on an analysis of the gearshift points in the in-use data. In order to establish generalized correlations between technical specifications of the vehicles and gearshift speeds, the engine speeds were normalized to the utilizable band between rated speed and idling speed.

1.2 In a second step, the end speeds (vehicle speed as well as normalised engine speed) for upshifts and downshifts were determined and recorded in a separate table. The averages of these speeds for each gear and vehicle were calculated and correlated with the vehicles' technical specifications.

1.3 The results of these analyses and calculations can be summarized as follows:

- a. the gearshift behavior is engine-speed-related rather than vehicle-speed-related;
- b. the best correlation between gearshift speeds and technical data was found for normalised engine speeds and the power-to-mass ratio (maximum continuous rated power/(mass in running order));
- c. the residual variations cannot be explained by other technical data or by different drive train ratios. They are most probably due to differences in traffic conditions and individual rider behavior;
- d. the best approximation between gearshift speeds and power-to-mass ratio was found for exponential functions;
- e. the gearshift mathematical function for the first gear is significantly lower than for all other gears;
- f. the gearshift speeds for all other gears can be approximated by one common mathematical function;
- g. no differences were found between five-speed and six-speed gearboxes;

1.4 The following equations for normalized engine upshift speeds:

Equation 1: Normalized upshift speed in 1st gear (gear 1)

$$n_{max\_acc(1)} = (0.5753 * e^{\left(-1.9 * \frac{P_n}{m_{ref}}\right)} - 0.1) * (S - n_{idle}) + n_{idle}$$

Equation 2: Normalized upshift speed in gears > 1

$$N_{max\_acc(i)} = (0.5753 * e^{\left(-1.9 * \frac{P_n}{m_{ref}}\right)} - 0.1) * (S - n_{idle}) + n_{idle}$$

## 2.0 CALCULATION EXAMPLE

2.1 Figure 1 of this Appendix shows an example of gearshift use for a small vehicle:

- (a) the lines in bold show the gear use for acceleration phases;
- (b) the dotted lines show the downshift points for deceleration phases;
- (c) in the cruising phases, the whole speed range between downshift speed and upshift speed may be used.

2.2 Where vehicle speed increases gradually during cruise phases, upshift speeds ( $v_{1 \rightarrow 2}$ ,  $v_{2 \rightarrow 3}$  and  $v_{i \rightarrow i+1}$ ) in km/h may be calculated using the following equations:

Equation 3

$$V_{1 \rightarrow 2} = [0.03 * (s - n_{idle}) + n_{idle}] * \frac{1}{ndV_2}$$

Equation 4

$$V_{2 \rightarrow 3} = \left[ \left( 0.5753 * e^{\left(-1.9 * \frac{P_n}{m_{ref}}\right)} - 0.1 \right) * (s - n_{idle}) + n_{idle} \right] * \frac{1}{ndV_1}$$

Equation 5

$$V_{i \rightarrow i+1} = \left[ \left( 0.5753 * e^{\left(-1.9 * \frac{P_n}{m_{ref}}\right)} - 0.1 \right) * (s - n_{idle}) + n_{idle} \right] * \frac{1}{ndV_{i-1}}, i=3 \text{ to ng}$$

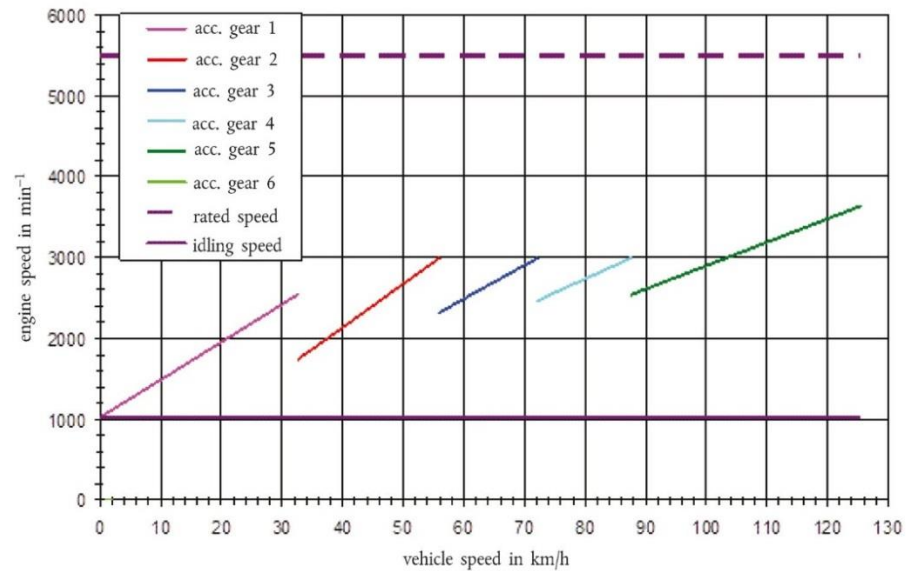
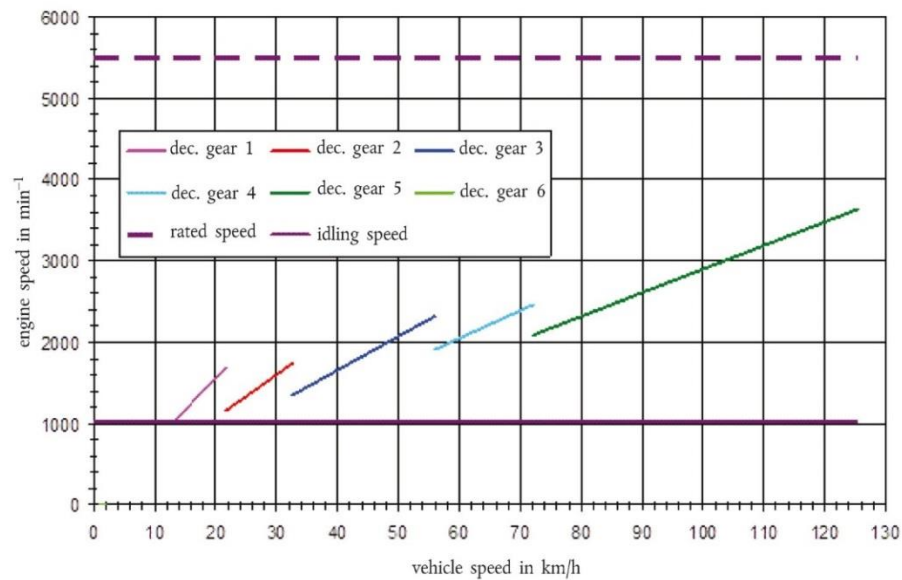

Figure 1

**Example of a gearshift sketch - Gear use during deceleration and cruise phases**

Gear use during acceleration phases



In order to allow the test agency more flexibility and to ensure drivability, the gearshift regression functions shall be considered as lower limits. Higher engine speeds are permitted in any cycle phase.

**3.0 PHASE INDICATORS**

3.1 In order to avoid different interpretations in the application of the gearshift equations and thus to improve the comparability of the test, fixed-phase indicators are assigned to the speed pattern of the cycles. as shown in the following table:

**Table 1**  
**Definition of driving modes**

<b>4 modes</b>	<b>Definition</b>
Idle mode	vehicle speed < 5 km/h and -0.5 km/h/s (-0.139 m/s <sup>2</sup> ) < acceleration < 0.5 km/h/s (0.139 m/s <sup>2</sup> )
Acceleration mode	acceleration > 0.5 km/h/s (0.139 m/s <sup>2</sup> )
Deceleration mode	acceleration < - 0.5 km/h/s (- 0.139 m/s <sup>2</sup> )
Cruise mode	vehicle speed ≥ 5 km/h and -0.5 km/h/s (-0.139 m/s <sup>2</sup> ) < acceleration < 0.5 km/h/s (0.139 m/s <sup>2</sup> )

3.2 The indicators were then modified in order to avoid frequent changes during relatively homogeneous cycle parts and thus improve driveability. Figure 2 of this Appendix shows an example from cycle part 1.

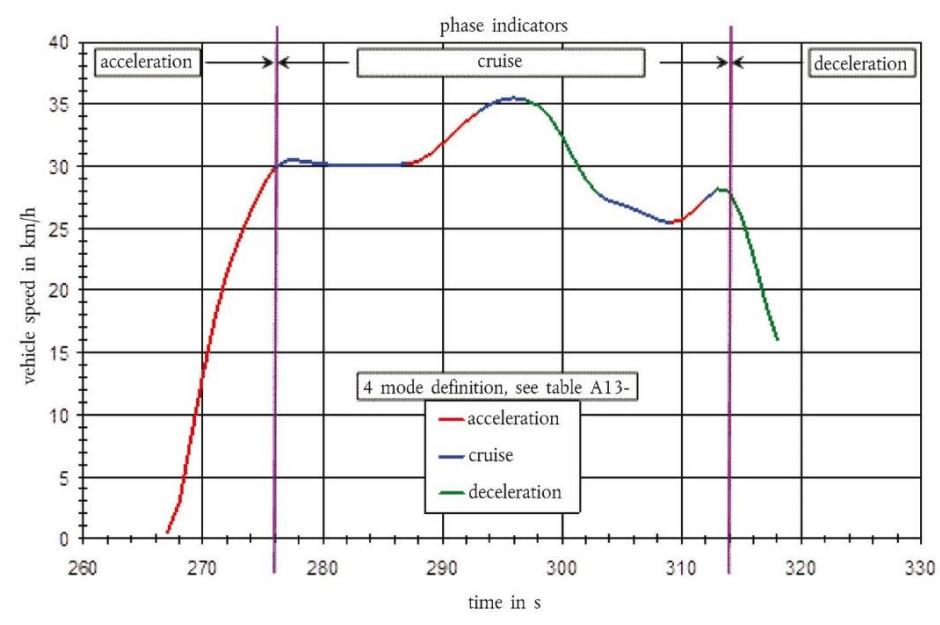

**Figure 2**  
**Example for modified phase indicators**

**4.0 CALCULATION EXAMPLE**

4.1 An example of input data necessary for the calculation of shift speeds is shown in Table 2 of this Appendix. The upshift speeds for acceleration phases for first gear and higher gears are calculated using Equations 1 and 2 of this Appendix. The de-normalisation of engine speeds can be performed using the equation  $n = n\_norm \times (s - nidle) + nidle$ .

4.2 The downshift speeds for deceleration phases can be calculated using Equations 3 and 4 of this Appendix. The  $ndv$  values in Table 2 of this Appendix can be used as gear ratios. These values can also be used to calculate the corresponding vehicle speeds (vehicle shift speed in gear  $i =$  engine shift speed in gear  $i/ndvi$ ). The results are shown in Tables Ap 3 and Ap 4 of this Appendix or Chapter.

4.3 Additional analyses and calculations were conducted to investigate whether these gearshift algorithms could be simplified and, in particular, whether engine shift speeds could be replaced by vehicle shift speeds. The analysis showed that vehicle speeds could not be brought in line with the gearshift behavior of the in-use data.

4.3.1

**Table 2**  
**Input data for the calculation of engine and vehicle shift speeds**

Item	Input data
Engine capacity in $cm^3$	600
$P_n$ in kW	72
$m_{ref}$ in kg	199
$s$ in $min^{-1}$	11800
$n_{idle}$ in $min^{-1}$	1150
$ndv_1$ (*)	133.66
$ndv_2$	94.91
$ndv_3$	76.16
$ndv_4$	65.69
$ndv_5$	58.85
$ndv_6$	54.04
$pmr$ (**) in kW/t	262.8

(\*)  $ndv$  means the ratio between engine speed in  $min^{-1}$  and vehicle speed in km/h

(\*\*)  $pmr$  means the power-to-mass ratio calculated by

$$1. \quad P_n / (m_{ref}) \cdot 1000; \quad P_n \text{ in kW, } m_{ref} \text{ in kg}$$



4.3.2

**Table 3****Shift speeds for acceleration phases for first gear and for higher gears**

(see Table 1 of this Appendix)

	<b>EU/USA/JAPAN DRIVING BEHAVIOUR</b>	
	EU/USA / Japan driving behavior	n_acc_max (1) n_acc_max (i)
n_norm (*) in percent	24.9	34.9
n in min <sup>-1</sup>	3804	4869

(\*) n\_norm means the value calculated using equations 1 and 2 of this Appendix

4.3.3

**Table 4****Engine and vehicle shift speeds based on Table 2 of this Appendix**

Gear shift		EU/USA/Japan driving behavior		
		v in km/h	n_norm (i) in percent	n in min <sup>-1</sup>
<b>Upshift</b>	1→2	28.5	24.9	3 804
	2→3	51.3	34.9	4 869
	3→4	63.9	34.9	4 869
	4→5	74.1	34.9	4 869
	5→6	82.7	34.9	4 869
<b>Downshift</b>	2→cl (*)	15.5	3.0	1 470
	3→2	28.5	9.6	2 167
	4→3	51.3	20.8	3 370
	5→4	63.9	24.5	3 762
	6→5	74.1	26.8	4 005

(\*) 'cl' means 'Clutch-Off' timing.

## APPENDIX 9 TO CHAPTER 2

### TYPE I TEST PROCEDURE FOR VEHICLES FUELED WITH LPG, NG/BIO-METHANE, FLEX FUEL H<sub>2</sub>NG OR HYDROGEN

#### 1.0 INTRODUCTION

- 1.1. This Appendix describes the special requirements as regards the testing of LPG, NG/biomethane, H<sub>2</sub>NG or hydrogen gas for the approval of alternative fuel vehicles that run on those fuels or can run on petrol, LPG, NG/biomethane, H<sub>2</sub>NG or hydrogen.
- 1.2. The composition of these gaseous fuels, as sold on the market, can vary greatly and fueling systems shall adapt their fueling rates accordingly. To demonstrate this adaptability, the parent vehicle equipped with a representative LPG, NG/biomethane or H<sub>2</sub>NG fuel system shall be tested in type I tests on two extreme reference fuels.
- 1.3. The requirements of this Appendix as regards hydrogen shall apply only to vehicles using hydrogen as a combustion fuel and not to those equipped with a fuel cell operating on hydrogen.
- 1.4. For CNG and LPG vehicles, the provisions of CMV Rule 115(B) and CMV Rule 115(C) as amended from time to time, shall apply.
- 1.5. Vehicles models and variants having option for Bi-fuel operation and fitted with limp-home gasoline tank of capacity not exceeding two litres on two wheelers shall be exempted from test in gasoline mode.

#### 2.0 **Granting of type approval for an L2-category vehicle equipped with a gaseous fuel system**

Type approval is granted subject to the following requirements:

- 2.1. Exhaust emissions approval of a vehicle equipped with a gaseous fuel system

It shall be demonstrated that the parent vehicle equipped with a representative LPG, NG/biomethane, H<sub>2</sub>NG or hydrogen fuel system can adapt to any fuel composition that may appear on the market and comply with the following:

- 2.1.1. In the case of LPG there are variations in C<sub>3</sub>/C<sub>4</sub> composition (test fuel requirement A and B) and therefore the parent vehicle shall be tested on reference fuels A and B referred to in BS VI emission norms

Reference Fuel shall be used for Type Approval and Conformity of Production two year after the same is available to the test agencies. Till then, Commercial LPG fuel shall be used as per applicable Gazette Notification under CMVR.

- 2.1.2. In the case of NG / biomethane there are generally two types of fuel, high calorific fuel (G20) and low calorific fuel (G25), but with a significant spread within both ranges; They differ significantly in Wobbe index. These variations are reflected in the reference fuels. The parent vehicle shall be tested on both reference fuels referred to in BS VI emission norms. Reference Fuel shall be used for Type Approval and Conformity of Production two year after the same is available to the test agencies. Till then, Commercial CNG/LPG fuel shall be used as per applicable Gazette Notification under CMVR.
- 2.1.3. In the case of a flex fuel H<sub>2</sub>NG vehicle, the composition range may vary from 0 % hydrogen (L-gas) to a maximum percentage of hydrogen within the mixture (H-gas), as specified by the manufacturer. It shall be demonstrated that the parent vehicle can adapt to any percentage within the range specified by the manufacturer and the vehicle shall be tested in the type I test on 100 % H-gas and 100 % L-gas. It shall also be demonstrated that it can adapt to any NG/biomethane composition that may appear on the market, regardless of the percentage of hydrogen in the mixture.
- 2.1.4. For vehicles equipped with hydrogen fuel systems, compliance shall be tested on the single hydrogen reference fuel referred to in the notification.
- 2.1.5. If the transition from one fuel to another is in practice aided through the use of a switch, this switch shall not be used during type approval. In such cases, at the manufacturer’s request and with the agreement of the test agency, the pre-conditioning cycle referred in Chapter 2 may be extended.
- 2.1.6. The ratio of emission results ‘r’ shall be determined for each pollutant as shown in Table 1 of this Appendix for LPG, NG/biomethane and H<sub>2</sub>NG vehicles.
  - 2.1.6.1. In the case of LPG and NG/biomethane vehicles, the ratios of emission results ‘r’ shall be determined for each pollutant as follows:

**Table 1**  
**Calculation ratio ‘r’ for LPG and NG/biomethane vehicles**

Type(s) of fuel	Reference fuels	Calculation of ‘r’
LPG and petrol (Approval B)	Fuel A	$r = \frac{B}{A}$
or LPG only (Approval D)	Fuel B	
NG/biomethane	fuel G20	$r = \frac{G25}{G20}$
	fuel G25	

**Note 1** –Limitation of exhaust emissions by the vehicle, evaporative emissions, crankcase emissions, durability of pollution control devices, cold start pollutant emissions and on-board diagnostics of vehicles fueled with unleaded petrol, or which can be fueled with either unleaded petrol and LPG (Approval B)

**Note 2** – Limitation of emissions of gaseous pollutants by the engine, crankcase emissions, durability of pollution control devices, cold start emissions and on-board diagnostics of vehicles fueled with LPG (Approval D).

- 2.1.6.2. In the case of flex fuel H<sub>2</sub>NG vehicles, two ratios of emission results ‘r1’ and ‘r2’ shall be determined for each pollutant as follows:

**Table 2**  
**Look-up table ratio ‘r’ for NG/biomethane or H<sub>2</sub>NG gaseous fuels**

Type(s) of fuel	Reference fuels	Calculation of ‘r’
NG/biomethane	fuel G20	$r_1 = \frac{G25}{G20}$
	fuel G25	
H <sub>2</sub> NG	Mixture of hydrogen and G20 with the maximum percentage of hydrogen specified by the manufacturer	$r_2 = \frac{H_2G25}{H_2G20}$
	Mixture of hydrogen and G25 with the maximum percentage of hydrogen specified by the manufacturer	

**2.2 Exhaust emissions approval of a member of the propulsion family**

For the type-approval of mono-fuel gas vehicles and bi-fuel vehicles operating in gas mode, fuelled by LPG, NG/biomethane, H<sub>2</sub>NG or hydrogen, as a member of the propulsion family in Chapter 7, a type I test shall be performed with one gaseous reference fuel. For LPG, NG/biomethane and H<sub>2</sub>NG vehicles, this reference fuel may be either of the reference fuels in Appendix 2. The gas-fuelled vehicle is considered to comply if the following requirements are met:

- 2.2.1. The test vehicle shall be selected based on definition of a propulsion family member in Chapter 7.
- 2.2.2. If the test fuel requirement is reference fuel A for LPG or G20 for NG/biomethane, the emission result shall be multiplied by the relevant factor ‘r’ if r > 1; if r < 1, no correction is needed.

- 2.2.3. If the test fuel requirement is reference fuel B for LPG or G25 for NG/biomethane, the emission result shall be divided by the relevant factor 'r' if  $r < 1$ ; if  $r > 1$ , no correction is needed.
- 2.2.4. At the manufacturer's request, the type I test may be performed on both reference fuels, so that no correction is needed.
- 2.2.5. The parent vehicle shall comply with the emission limits set out in BS VI emission norms and for both measured and calculated emissions.
- 2.2.6. If repeated tests are conducted on the same engine, an average shall first be taken of the results on reference fuel G20, or A, and those on reference fuel G25, or B; the 'r' factor shall then be calculated from these averages.
- 2.2.7. For the type approval of a flex fuel H<sub>2</sub>NG vehicle as a member of a family, two type I tests shall be performed, the first test with 100 % of either G20 or G25, and the second test with the mixture of hydrogen and the same NG/biomethane fuel used during the first test, with the maximum hydrogen percentage specified by the manufacturer.
- 2.2.7.1. If the NG/biomethane fuel is the reference fuel G20, the emission result for each pollutant shall be multiplied by the relevant factors ( $r_1$  for the first test and  $r_2$  for the second test) in clause 2.1.6 of this Appendix. if the relevant factor  $> 1$ ; if the correspondent relevant factor  $< 1$ , no correction is needed.
- 2.2.7.2. If the NG/biomethane fuel is the reference fuel G25, the emission result for each pollutant shall be divided by the corresponding relevant factor ( $r_1$  for the first test and  $r_2$  for the second test) calculated in accordance with clause 2.1.6 of this Appendix., if this is  $< 1$ ; if the corresponding relevant factor is  $> 1$ , no correction is needed.
- 2.2.7.3. At the manufacturer's request, the type I test shall be conducted with the four possible combinations of reference fuels, in accordance with clause 2.1.6.of this Appendix, so that no correction is needed.
- 2.2.7.4. If repeated tests are carried out on the same engine, an average shall first be taken of the results on reference fuel G20, or H<sub>2</sub>G20, and those on reference fuel G25, or H<sub>2</sub>G25 with the maximum hydrogen percentage specified by the manufacturer; The 'r<sub>1</sub>' and 'r<sub>2</sub>' factors shall then be calculated from these averages.
- 2.2.8. During the type I test, the vehicle shall use only petrol for a maximum of 60 consecutive seconds directly after engine crank and start when operating in gas fueling mode. In the case of the use of LPG or CNG as a fuel, it is permissible that the engine is started on petrol and switched to LPG or CNG after a predetermined period of time which cannot be changed by the driver.

**APPENDIX 10 TO CHAPTER 2****TYPE I TEST PROCEDURE FOR VEHICLES EQUIPPED WITH A PERIODICALLY REGENERATING SYSTEM****1.0 INTRODUCTION**

This Appendix contains specific provisions regarding the type approval of vehicles equipped with a periodically regenerating system.

**2.0 SCOPE**

Scope of the type approval for vehicles with a periodically regenerating system as regards type I tests

2.1. L2 - category vehicles that are equipped with periodically regenerating systems shall comply with the requirements in this Appendix.

2.2. Instead of carrying out the test procedures in the following point, a fixed  $K_i$  value of 1.05 may be used if the manufacturer sees no reason why this value could be exceeded and after approval of testing agency

2.3. During cycles where regeneration occurs, emission standards can be exceeded. If a regeneration of an anti-pollution device occurs at least once per Type I test and that has already regenerated at least once during the vehicle preparation cycle, it will be considered as a continuously regenerating system which does not require a special test procedure.

2.4. "Periodically regenerating system" means an anti-pollution device (e.g. catalytic converter, particulate trap) that requires a periodical regeneration process in less than 4,000 km of normal vehicle operation. During cycles where regeneration occurs, emission standards can be exceeded. If a regeneration of an anti-pollution device occurs at least once per Type I test and that has already regenerated at least once during vehicle preparation cycle, it will be considered as a continuously regenerating system which does not require a special test procedure. This Appendix does not apply to continuously regenerating systems.

At the request of the manufacturer, the test procedure specific to periodically regenerating systems will not apply to a regenerative device if the manufacturer provides data to the type test agency that, during cycles where regeneration occurs, emissions remain below the standards given in the notification for the concerned vehicle category after agreement of the test agency.

**3.0 TEST PROCEDURE**

The vehicle may be equipped with a switch capable of preventing or permitting the regeneration process provided that its operation has no effect on original engine calibration. This switch shall be used for the purpose of preventing regeneration only during loading of the regeneration system and during the pre-conditioning cycles. However, it shall not be used during the measurement of emissions in the regeneration phase;

rather the emission test shall be carried out with the unchanged original equipment manufacturers powertrain control unit / engine control unit / drive train control unit if applicable and powertrain software.

3.1. Measurement of carbon dioxide emission / fuel consumption and mass emissions between two cycles where regenerative phases occur.

3.1.1. The average of carbon dioxide emission / fuel consumption and mass emissions between regeneration phases and during loading of the regenerative device shall be determined from the arithmetic mean of several approximately equidistant (if more than two) type I operating cycles.

Carbon dioxide emission / fuel consumption and mass emissions shall be measured for at least two type I operating cycles: one immediately after regeneration (before new loading) and one as immediately as possible before a regeneration phase. All emissions measurements and calculations shall be carried out in accordance with Chapter 2. Average emissions for a single regenerative system shall be determined in accordance with clause 3.3 of this Appendix and for multiple regeneration systems in accordance with clause 3.4 of this Appendix.

3.1.2. The loading process and  $K_i$  determination shall be carried out on a chassis dynamometer during the type I operating cycles. These cycles may be run continuously (i.e. without the need to switch the engine off between cycles). After any number of completed cycles, the vehicle may be removed from the chassis dynamometer and the test continued at a later time.

3.1.3. The number of cycles (D) between two cycles in which regeneration phases occur, the number of cycles over which emissions measurements are taken (n) and each emissions measurement ( $M'_{sij}$ ) shall be reported in test report.

3.2. Measurement of carbon dioxide emission / fuel consumption and mass emissions during regeneration

3.2.1. If necessary, the vehicle may be prepared for the emissions test during a regeneration phase using the preparation cycles in Appendix 5.

3.2.2. The test and vehicle conditions for the type I test described in Chapter 2 apply before the first valid emission test is carried out.

3.2.3. Regeneration shall not occur during the preparation of the vehicle. This may be ensured by one of the following methods:

3.2.3.1 A 'dummy' regenerating system or partial system may be fitted for the pre-conditioning cycles;

3.2.3.2 Any other method agreed between the manufacturer and the testing agency.

- 3.2.4. A cold start exhaust emission test including a regeneration process shall be carried out in accordance with the applicable type I operating cycle.
- 3.2.5. If the regeneration process requires more than one operating cycle, subsequent test cycle(s) shall be driven immediately, without switching the engine off, until complete regeneration has been achieved (each cycle shall be completed). The time necessary to set up a new test shall be as short as possible (e.g. as required to change a particulate matter filter on the analyzing equipment). The engine shall be switched off during this period.
- 3.2.6. The emission values, during regeneration ( $M_{ri}$ ) shall be calculated in accordance with Type I test procedure described in Chapter 2 and clause 3.3 of this Appendix. The number of operating cycles ( $d$ ) measured for complete regeneration shall be recorded.
- 3.3. Calculation of the combined exhaust emissions of a single regenerative system:

Equation 1

$$(1) \quad M_{si} = \frac{\sum_{j=1}^n M'_{sij}}{n} \quad n \geq 2$$

Equation 2

$$(2) \quad M_{ri} = \frac{\sum_{j=1}^d M'_{rij}}{d}$$

Equation 3

$$(3) \quad M_{pi} = \left\{ \frac{M_{si} * D + M_{ri} * d}{D + d} \right\}$$

Where for each pollutant (i) considered:

$M'_{sij}$  = mass emissions of pollutant (i), mass emissions of CO<sub>2</sub> in g/km / fuel consumption in l/100 km over one type I operating cycle without regeneration;

$M'_{rij}$  = mass emissions of pollutant (i), mass emissions of CO<sub>2</sub> in g/km / fuel consumption in l/100 km over one type I operating cycle during regeneration (when  $n > 1$ , the first type I test is run cold, and subsequent cycles are hot);

$M_{si}$  = mean mass emissions of pollutant (i) in mg/km or mean mass emissions of CO<sub>2</sub> in g/km / fuel consumption in l/100 km over one part (i) of the operating cycle without regeneration;



$M_{ri}$  = mean mass emissions of pollutant (i) in mg/km or mean mass emissions of CO<sub>2</sub> in g/km / fuel consumption in l/100 km over one part (i) of the operating cycle during regeneration;

$M_{pi}$  = mean mass emissions of pollutant (i) in mg/km or mean mass emissions of CO<sub>2</sub> in g/km / fuel consumption in l/100 km;

$n$  = number of test points at which emissions measurements (Type I operating cycles) are taken between two cycles where regenerative phases occur,  $\geq 2$

$d$  = number of operating cycles required for regeneration.

$D$  = number of operating cycles between two cycles where regenerative phases occur.

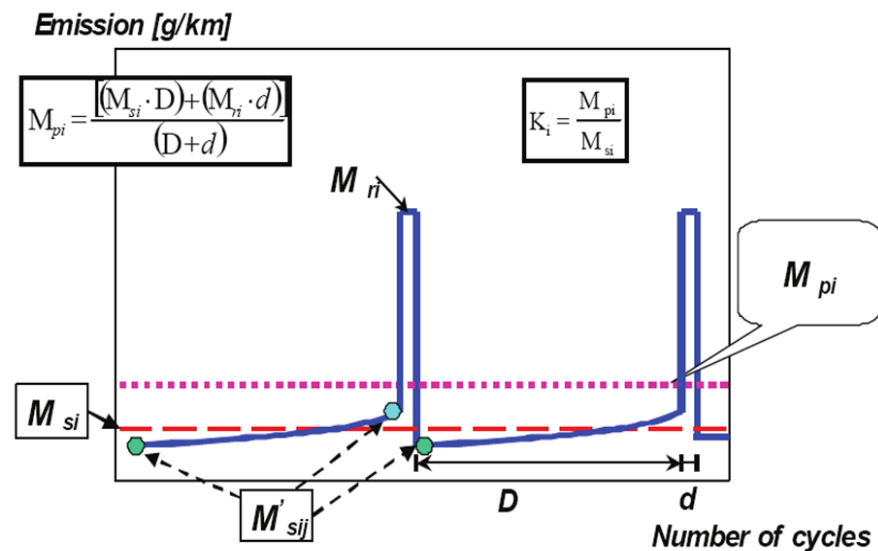

FIGURE 1

**Example of measurement parameters. Parameters measured during emissions or fuel consumption test during and between cycles in which regeneration occurs (schematic example – the emissions during ‘D’ may increase or decrease)**

3.3.1. Calculation of the regeneration factor  $K$  for each pollutant (i), carbon dioxide emission / fuel consumption considered:

Equation 4

$$K_i = M_{pi} / M_{si}$$

$M_{si}$ ,  $M_{pi}$  and  $K_i$  results shall be recorded in the test report delivered by the test agency.  $K_i$  may be determined following the completion of a single sequence.

3.4. Calculation of combined exhaust emissions, carbon dioxide emissions / fuel consumption of multiple periodic regenerating systems

Equation 5

$$(1) \quad M_{sik} = \frac{\sum_{j=1}^{n_k} M'_{sik,j}}{n_k} \quad n_k \geq 2$$

Equation 6

$$(2) \quad M_{rik} = \frac{\sum_{j=1}^{d_k} M'_{rik,j}}{d_j}$$

Equation 7

$$(3) \quad M_{si} = \frac{\sum_{k=1}^x M_{sik} \cdot D_k}{\sum_{k=1}^x D_k}$$

Equation 8

$$(4) \quad M_{ri} = \frac{\sum_{k=1}^x M_{rik} \cdot d_k}{\sum_{k=1}^x d_k}$$

Equation 9

$$(5) \quad M_{pi} = \frac{M_{si} \cdot \sum_{k=1}^x D_k + M_{ri} \cdot \sum_{k=1}^x d_k}{\sum_{k=1}^x (D_k + d_k)}$$

Equation 10

$$(6) \quad M_{pi} = \frac{\sum_{k=1}^x (M_{sik} \cdot D_k + M_{rik} \cdot d_k)}{\sum_{k=1}^x (D_k + d_k)}$$

Equation 11

$$(7) \quad K_i = \frac{M_{pi}}{M_{si}}$$

Where for each pollutant (i) considered:

- a.  $M'_{sik}$  = mass emissions of event k of pollutant (i) in mg/km, mass emissions of CO<sub>2</sub> in g/km / fuel consumption in l/100 km over one type I operating cycle without regeneration;
- b.  $M'_{rik}$  = mass emissions of event k of pollutant (i) in mg/km, mass emissions of CO<sub>2</sub> in g/km / fuel consumption in l/100 km over one type I operating cycle during regeneration (if  $d > 1$ , the first type I test is run cold, and subsequent cycles are hot);
- c.  $M'_{sik,j}$  = mass emissions of event k of pollutant (i) in mg/km, mass emissions of CO<sub>2</sub> in g/km / fuel consumption in l/100 km over one type I operating cycle without regeneration measured at point j;  $1 \leq j \leq n$ ;
- d.  $M'_{rik,j}$  = mass emissions of event k of pollutant (i) in mg/km, mass emissions of CO<sub>2</sub> in g/km / fuel consumption in l/100 km over one type I operating cycle during regeneration (when  $j > 1$ , the first type I test is run cold, and subsequent cycles are hot) measured at operating cycle j;  $1 \leq j \leq d$ ;
- e.  $M_{si}$  = mass emission of all events k of pollutant (i) in mg/km, of CO<sub>2</sub> in g/km / fuel consumption in l/100 km without regeneration;
- f.  $M_{ri}$  = mass emission of all events k of pollutant (i) in mg/km, of CO<sub>2</sub> in g/km / fuel consumption in l/100 km during regeneration;
- g.  $M_{pi}$  = mass emission of all events k of pollutant (i) in mg/km, of CO<sub>2</sub> in g/km / fuel consumption in l/100 km;
- h.  $n_k$  = number of test points of event k at which emissions measurements (type I operating cycles) are taken between two cycles in which regenerative phases occur;
- i.  $d_k$  = number of operating cycles of event k required for regeneration ;
- j.  $D_k$  = number of operating cycles of event k between two cycles in which regenerative phases occur.

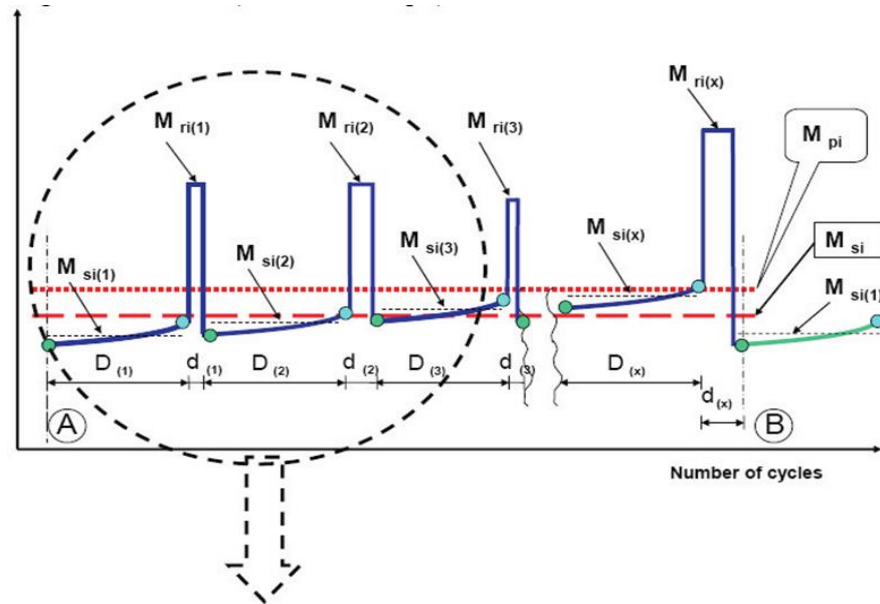
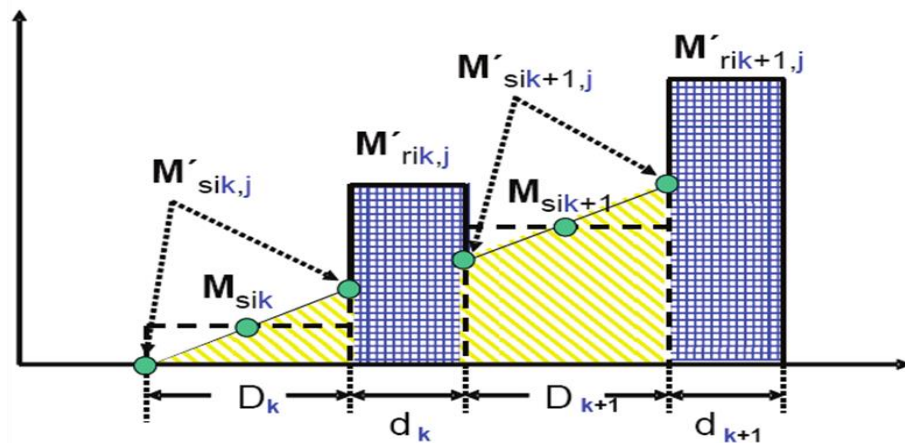

**FIGURE 2**

**Parameters measured during emissions test during and between cycles in which regeneration occurs (schematic example)**

For more details of the schematic process see Figure 3 of this Appendix:

For application of a simple and realistic case, the following description gives a detailed explanation of the schematic example shown in Figure 3 of this Appendix or Chapter:



**FIGURE 3**

**Parameters measured during emissions test during and between cycles where regeneration occurs (schematic example)**

‘Particulate Filter’: regenerative, equidistant events, similar emissions ( $\pm 15$  percent) from event to event

$$D_k = D_{k+1} = D_1$$

$$d_k = d_{k+1} = d_1$$

$$M_{rik} - M_{sik} = M_{rik+1} - M_{sik+1}$$

$$n_k = n$$

‘DeNOx’: the desulphurisation (SO<sub>2</sub> removal) event is initiated before an influence of sulphur on emissions is detectable (±15 percent of measured emissions) and in this example, for exothermic reasons, together with the last DPF regeneration event.

$$M'_{sik,j=1} = \text{constant} \quad M_{sik} = M_{sik+1} = M_{si2} \quad M_{rik} = M_{rik+1} = M_{ri2}$$

For SO<sub>2</sub> removal event: M<sub>ri2</sub>, M<sub>si2</sub>, d<sub>2</sub>, D<sub>2</sub>, n<sub>2</sub> = 1

Complete system (DPF + DeNOx):

Equation 12

$$M_{si} = \frac{n \cdot M_{si1} \cdot D_1 + M_{si2} \cdot D_2}{n \cdot D_1 + D_2}$$

Equation 13

$$M_{ri} = \frac{n \cdot M_{ri1} \cdot d_1 + M_{ri2} \cdot d_2}{n \cdot d_1 + d_2}$$

Equation 14

$$M_{pi} = \frac{M_{si} + M_{ri}}{n \cdot (D_1 + d_1) + D_2 + d_2} = \frac{n \cdot (M_{si1} \cdot D_1 + M_{ri1} \cdot d_1) + M_{si2} \cdot D_2 + M_{ri2} \cdot d_2}{n \cdot (D_1 + d_1) + D_2 + d_2}$$

The calculation of the factor (K<sub>i</sub>) for multiple periodic regenerating systems is possible only after a certain number of regeneration phases for each system. After performing the complete procedure (A to B, see Figure 2 of this Appendix), the original starting conditions A should be reached again.

- 3.4.1. Extension of approval for a multiple periodic regeneration system
  - 3.4.1.1. If the technical parameters or the regeneration strategy of a multiple regeneration system for all events within this combined system are changed, the complete procedure including all regenerative devices shall be performed by measurements to update the multiple K<sub>i</sub> – factor.
  - 3.4.1.2. If a single device of the multiple regeneration system is changed only in strategy parameters (i.e. such as ‘D’ or ‘d’ for DPF) and the manufacturer can provide the plausible technical data to the test agency and information demonstrating that:
    - (a) There is no detectable interaction with the other device(s) of the system; and

The important parameters (i.e. construction, working principle, volume, location, etc.) are identical,

The necessary update procedure for k<sub>i</sub> may be simplified.

In such cases, where agreed between the manufacturer and the test agency, only a single event of sampling/storage and regeneration shall be performed and the test results ('M<sub>si</sub>', 'M<sub>ri</sub>'), in combination with the changed parameters ('D' or 'd'), may be introduced into the relevant formula (e) to update the multiple K<sub>i</sub> - factor mathematically by substituting the existing basic K<sub>i</sub> - factor formula (e).

## APPENDIX 11 TO CHAPTER 2

### CONFORMITY OF PRODUCTION (COP) - TECHNICAL REQUIREMENTS

#### 1.0 INTRODUCTION

Every produced vehicle of the model approved under this CMV Rule 115 (19(i)) shall conform, with regard to components affecting the emission of gaseous pollutants by the engine to the vehicle model type approved. The administrative procedure for carrying out conformity of production is given in Part 6 of AIS 137 of this document.

#### 2.0 TYPE I TEST: VERIFYING THE AVERAGE EMISSION OF GASEOUS POLLUTANTS:

For verifying the conformity of production in a Type I Test, the following procedure as per Option 1 is adopted.

2.1 To verify the average tailpipe emissions of gaseous pollutants of low volume vehicles with Annual production less than 250 per 6 months, manufacture can choose from the Option 1 or Option 2 as listed below:

2.2 Run-in

For COP vehicle shall have been run-in either as per manufacturer's specification but not more than 1000 km before the test.

#### 3.0 OPTION 1

3.1 The vehicle samples taken from the series, as described in clause 1 of this appendix is subjected to the single Type-I test described in Chapter 2. The results shall be calculated by the deterioration factors applied at the time of type approval. The resultant masses of gaseous emissions and in addition in case of vehicle equipped with compression ignition engine, the mass of particulates obtained in the test shall not exceed the applicable limits.

3.2 Procedure for Conformity of Production as per Bharat Stage-VI for 2 Wheelers vehicles

3.2.1 Conformity of production shall be verified as per Bharat Stage VI emission norms for 2 wheeler vehicles as given in notification and with the procedure given below.

3.2.2 To verify the average tailpipe emissions of gaseous pollutants following procedure shall be adopted.

3.2.3 With a minimum sample size of three, the sampling procedure is set so that the probability of a lot passing a test with 40 % of the production defective is 0.95 (producer's risk = 5 %), while the probability of a lot being accepted with 65 % of the production defective is 0.1 (consumer's risk = 10 %).

Minimum of three vehicles shall be selected randomly from the series with a sample lot size as defined in Part 6 of AIS 137.

- 3.2.4 After selection by the testing agency, the manufacturer shall not undertake any adjustments to the vehicles selected, except those permitted in Part 6 of AIS 137.
- 3.2.5 All three randomly selected vehicles shall be tested for a Type -1 test as per Chapter 2
- 3.2.6 Let  $X_{i1}$ ,  $X_{i2}$  &  $X_{i3}$  are the test results for the vehicle Sample No.1, 2 & 3.
- 3.2.7 If the natural Logarithms of the measurements in the series are  $X_1, X_2, X_3, \dots, X_j$  and  $L_i$  is the natural logarithm of the limit value for the pollutant, then define :

$$d_j = X_j - L_i$$

$$\bar{d}_n = \frac{1}{n} \sum_{j=1}^n d_j$$

$$V_n^2 = \frac{1}{n} \sum_{j=1}^n (d_j - \bar{d}_n)^2$$

- 3.2.8** Table 1 of this Appendix or Chapter chapter shows values of the pass ( $A_n$ ) and fails ( $B_n$ ) decision numbers against current sample number. The test statistic is the ratio  $\bar{d}_n/V_n$  and must be used to determine whether the series has passed or failed as follows :

Pass the series, if  $\bar{d}_n/V_n \leq A_n$  for all the pollutants

Fail the series if  $\bar{d}_n/V_n \geq B_n$  for any one of the pollutants.

Increase the sample size by one, if  $A_n < \bar{d}_n/V_n < B_n$  for any one of the pollutants. When a pass decision is reached for one pollutant, that decision will not be changed by any additional tests carried out to reach a decision for the other pollutants. In extended COP if earlier pass pollutants values are significantly high, then test agency will consider all pollutants for pass fail decision.

- If no pass decision is reached for all the pollutants and no fail decision is reached for one pollutant, a test shall be carried out on another randomly selected sample till a pass or fail decision is arrived at.



Option I : COP Test Procedure as per Bharat Stage VI for 2 wheeler

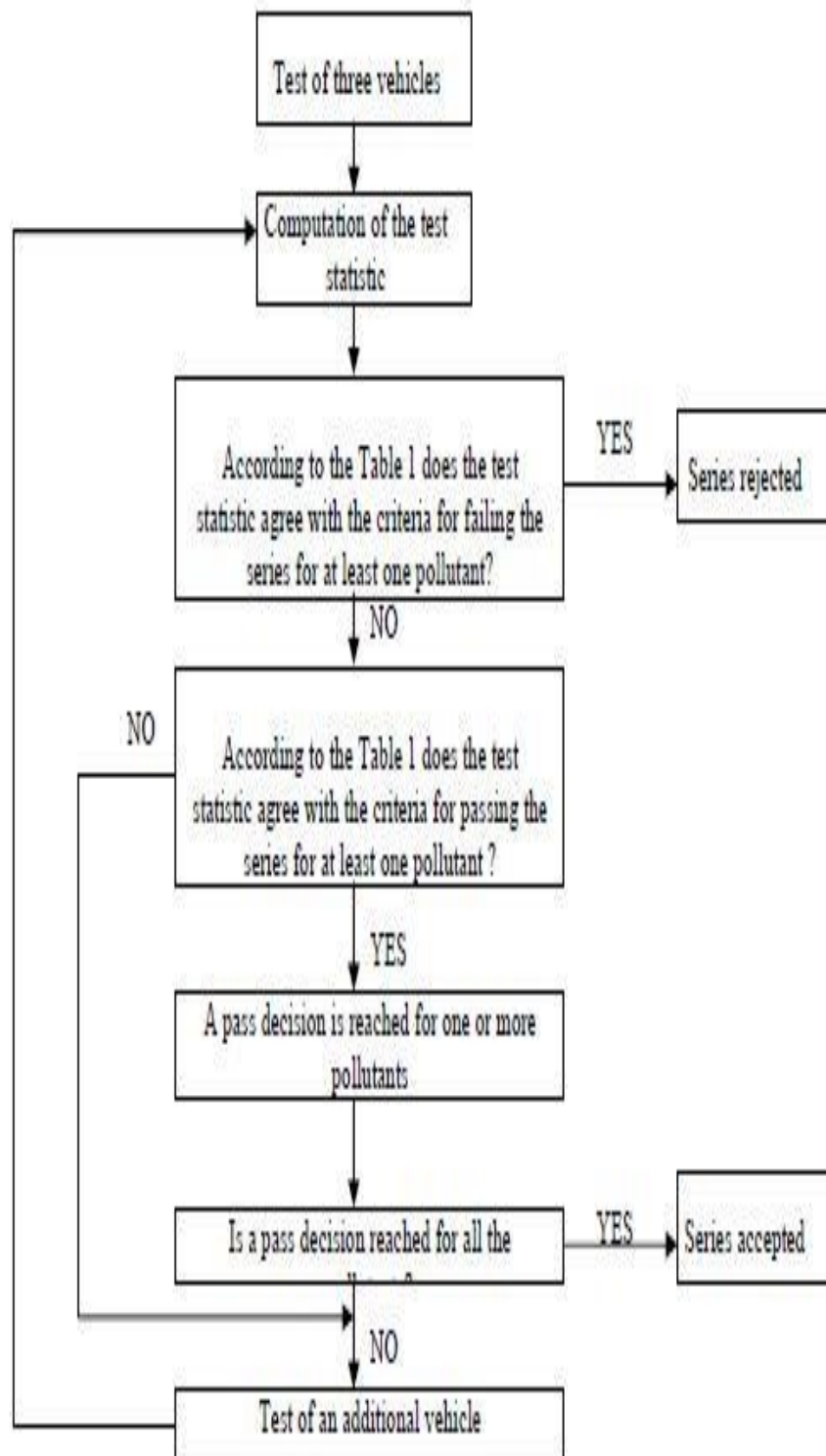

**Figure 1**  
Applicable for COP Procedure as per Bharat Stage VI for 2 Wheeler

Table 1

Sample Size	Pass Decision threshold ( $A_n$ )	Fail Decision threshold ( $B_n$ )
3	-0.80381	16.64743
4	-0.76339	7.68627
5	-0.72982	4.67136
6	-0.69962	3.25573
7	-0.67129	2.45431
8	-0.64406	1.94369
9	-0.61750	1.59105
10	-0.59135	1.33295
11	-0.56542	1.13566
12	-0.53960	0.97970
13	-0.51379	0.85307
14	-0.48791	0.74801
15	-0.46191	0.65928
16	-0.43573	0.58321
17	-0.40933	0.51718
18	-0.38266	0.45922
19	-0.35570	0.40788
20	-0.32840	0.36203
21	-0.30072	0.32078
22	-0.27263	0.28343
23	-0.24410	0.24943
24	-0.21509	0.21831
25	-0.18557	0.18970
26	-0.15550	0.16328
27	-0.12483	0.13880
28	-0.09354	0.11603
29	-0.06159	0.09480
30	-0.02892	0.07493
31	0.00449	0.05629
32	0.03876	0.03876

**4.0 OPTION 2**

- 4.1 Minimum of three vehicles shall be selected randomly from the series with a sample lot size.
- 4.2 After selection by the testing agency, the manufacturer shall not undertake any adjustments to the vehicles selected, except those permitted in Part 6 of AIS 137.
- 4.3 First vehicle out of three randomly selected vehicles shall be tested for Type – I test as per Chapter 2
- 4.4 Only one test (V1) shall be performed if the test results for all the pollutants meet 70 % of their respective limit values (i.e.  $V1 \leq 0.7L$  & L being the COP Limit)
- 4.5 Only two tests shall be performed if the first test results for all the pollutants doesn't exceed 85% of their respective COP limit values (i.e.  $V1 \leq 0.85L$ ) and at the same time one of these pollutant value exceeds 70% of the limit (i.e.  $V1 > 0.7L$ ) In addition, to reach the pass decision for the series, combined results of V1 & V2 shall satisfy such requirement that:  $(V1 + V2) < 1.70L$  and  $V2 < L$  for all the pollutants.
- 4.6 Third Type - I (V3) test shall be performed if the para 4.5 doesn't satisfy and if the second test results for all pollutants are within the 110% of the prescribed COP limits, Series passes only if the arithmetical mean for all the pollutants for three type I tests do not exceed their respective limit value i.e.  $(V1 + V2 + V3)/3 < L$ .
- 4.7 If one of the three test results obtained for any one of the pollutants exceed 10% of their respective limit values the test shall be continued on Sample No. 2 & 3 as given in the Figure 2 of this Appendix, as the provision for extended COP and shall be informed by the test agency to the nodal agency
- 4.8 These randomly selected sample No.2 & 3 shall be tested for only one Type – I test as per Chapter 2
- 4.9 Let  $X_{i2}$  &  $X_{i3}$  are the test results for the Sample No.2 & 3 and  $X_{i1}$  is the test result of the Sample No.1 which is the arithmetical mean for the three type – I tests conducted on Sample No. 1
- 4.10 If the natural Logarithms of the measurements in the series are  $X_1, X_2,$

$$d_j = X_j - L_i$$

$$d_n = \frac{1}{n} \sum_{j=1}^n d_j$$

$$V_n^2 = \frac{1}{n} \sum_{j=1}^n (d_j - \overline{d_n})^2$$

$X_3, \dots, X_j$  and  $L_i$  is the natural logarithm of the limit value for the pollutant, then define:

4.11 Table 1 of this Appendix or Chapter shows values of the pass ( $A_n$ ) and fails ( $B_n$ ) decision numbers against current sample number. The test statistic is the ratio  $\bar{d}_n / V_n$  and shall be used to determine whether the series has passed or failed as follows: -

- Pass the series,  $\bar{d}_n / V_n \leq A_n$  for all the pollutants
- Fail the series if  $\bar{d}_n / V_n \geq B_n$  for any one of the pollutants.
- Increase the sample size by one, if  $A_n < \bar{d}_n / V_n < B_n$  for any one of the pollutants.

4.12 When a pass decision is reached for one pollutant, that decision will not be changed by any additional tests carried out to reach a decision for the other pollutants. In extended COP if earlier pass pollutants values are significantly high, then test agency will consider all pollutants for pass fail decision.

4.13 If no pass decision is reached for all the pollutants and no fail decision is reached for one pollutant, a test shall be carried out on another randomly selected sample till a pass or fail decision is arrived at.

**5.0** These tests shall be conducted with the reference fuel as specified in the notification. However, at the manufacturer's request, tests may be carried out with commercial fuel.

**6.0 TYPE II TEST: CARBON-MONOXIDE AND HYDROCARBONS EMISSION AT IDLING SPEED:**

When the vehicle taken from the series for the first Type I test mentioned in clause 2 above, subjected to the test described in Chapter 3 of this Part for verifying the carbon monoxide and hydrocarbon emission at idling speed shall meet the limit values specified in CMVR rule no. 115(2)(i). If it does not, another 10 vehicles shall be taken from the series at random and shall be tested as per Chapter 3 of this Part. These vehicles can be same as those selected for carrying out Type I test. Additional vehicles if required, shall be selected for carrying out for Type II test. At least 9 out of 10 vehicles should meet the limit values specified in CMVR rule no. 115(2)(i). Then the series is deemed to conform.

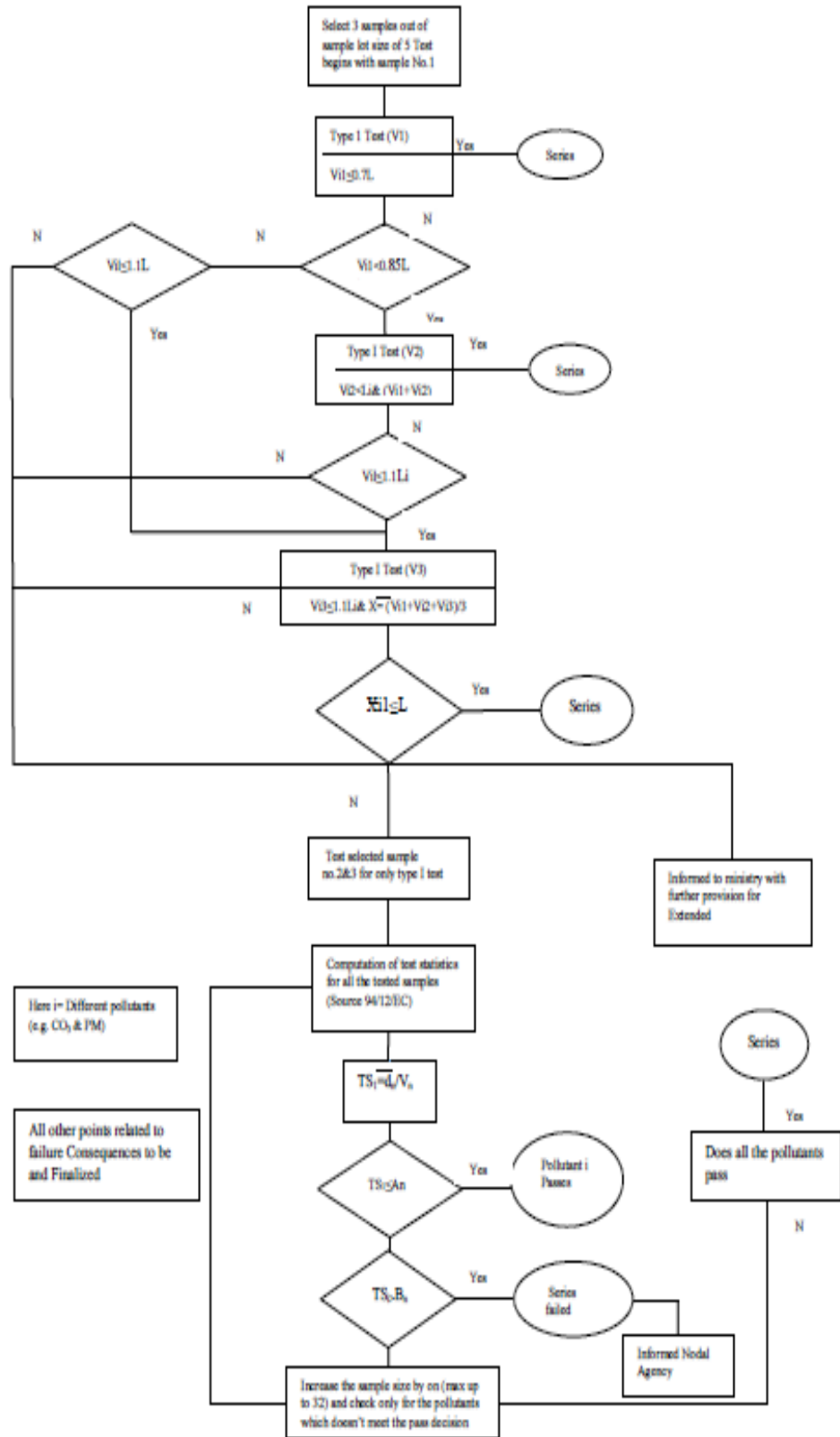

**Figure 2**  
**OPTION II: COP Test Procedure as per Bharat Stage VI for 2 Wheeler**

**APPENDIX 12 TO CHAPTER 2**  
**TYPE I TEST PROCEDURE FOR HYBRID L2-CATEGORY VEHICLES**

**1.0 INTRODUCTION**

- 1.1. This Appendix defines the specific provisions regarding type-approval of hybrid electric L2-category vehicles (HEV).
- 1.2. In principle, for the environmental type I to VIII test, hybrid electric vehicles shall be tested in accordance with this part, unless otherwise provided for in this Appendix.
- 1.3. For the type I and type VII tests, off-vehicle charging (OVC) vehicles (as categorized in clause 2 of this Appendix) shall be tested according to Conditions A and B as mentioned in clause 3.1.1 of this Appendix. Both sets of test results and the weighted values shall be reported in the test report drafted in accordance with the template referred to in Chapter 8
- 1.4. The emissions test results shall comply with the limits set-out the notification under all test conditions specified in this part.

**2.0 CATEGORIES OF HYBRID VEHICLES**

**Table 1**  
**Hybrid vehicle categories**

Vehicle charging	Off-Vehicle Charging <sup>(1)</sup> (OVC)		Not-off-vehicle Charging <sup>(2)</sup> (NOVC)	
	Without	With	Without	With
Operating mode switch				

<sup>(1)</sup> Also known as ‘externally chargeable’.

<sup>(2)</sup> Also known as ‘not externally chargeable’.

Refer Table 2 of this Appendix.

**3.0 TYPE I TEST METHODS**

For the type I test, hybrid electric L2-category vehicles shall be tested according to the applicable procedure in this part. For each test condition, the pollutant emission test result shall comply with the limits in the notification.

3.1. **Externally chargeable vehicles (OVC HEVs) without an operating mode switch**

3.1.1. **Two tests shall be performed under the following conditions:**

- a) condition A: the test shall be carried out with a fully charged electrical energy device /REESS
- (b) Condition B: the test shall be carried out with an electrical energy device /REESS in minimum state of charge (maximum discharge of capacity).

The profile of the state of charge (SOC) of the electrical energy device / REESS during different stages of the test is given in Appendix 3.1.to Chapter 8.

3.1.2. **Condition A**

3.1.2.1. The procedure shall start with the discharge of the electrical energy device /REESS of the vehicle while driving (on the test track, on a chassis dynamometer, etc.) in any of the following conditions

- (a) at a steady speed of 50 km/h until the fuel-consuming engine starts up;
- (b) if a vehicle cannot reach a steady speed of 50 km/h without the fuel-consuming engine starting up, the speed shall be reduced until it can run at a lower steady speed at which the fuel-consuming engine does not start up for a defined time or distance (to be determined by the test agency and the manufacturer subjected to the agreement of the test agency);
- (c) in accordance with the manufacturer's recommendation.

The fuel-consuming engine shall be stopped within ten seconds of being automatically started.

3.1.2.2. **Conditioning of vehicle**

The vehicle shall be conditioned by driving the applicable type I driving cycle as set out in Appendix 6 to chapter 2.

3.1.2.3. After this preconditioning and before testing, the vehicle shall be kept in a room in which the temperature remains relatively constant between 293.2 K and 303.2 K (20 °C and 30 °C). This conditioning shall be carried out for at least six hours and continue until the temperature of the engine oil and coolant, if any, are within  $\pm 2^{\circ}\text{C}$  of the temperature of the room, and the electrical energy device /REESS is fully charged as a result of the charging prescribed in clause 3.1.2.4 of this Appendix

3.1.2.4. During soak, the electrical energy device /REESS shall be charged with any of the following

- (a) the on-board charger if fitted;
- (b) an external charger recommended by the manufacturer and referred to in the user manual, using the normal overnight charging procedure set out in clause 3.2.2.4. of Appendix 3 to Chapter 8.

This procedure excludes all types of special charges that could be automatically or manually initiated, e.g. equalization or servicing charges

The manufacturer shall declare that a special charge procedure has not occurred during the test;

End-of-charge criterion.

The end-of-charge criterion corresponds to a charging time of 12 hours, except where the standard instrumentation gives the driver a clear indication that the electrical energy storage device is not yet fully charged.

In this case, the maximum time is = 3 times the claimed battery capacity (Wh) / mains power supply (W).

3.1.2.5. **Test procedure**

3.1.2.5.1. The vehicle shall be started up by the means provided to the driver for normal use. The first test cycle starts on the initiation of the vehicle start-up procedure.

3.1.2.5.2. The test procedures described in clauses 3.1.2.5.2.1. or 3.1.2.5.2.2. of this Appendix shall be used in accordance with the type I test procedure set out in Appendix 6 to chapter 2.

3.1.2.5.2.1. Sampling shall begin (BS) before or at the initiation of the vehicle start-up procedure and end on conclusion of the final idling period of the applicable type I test cycle (end of sampling (ES)).

3.1.2.5.2.2. Sampling shall begin (BS) before or at the initiation of the vehicle start-up procedure and continue over a number of repeat test cycles. It shall end on conclusion of the final idling period in the applicable type I test cycle during which the battery reached the minimum state of charge in accordance with the following procedure (end of sampling (ES)):

3.1.2.5.2.2.1. the electricity balance  $Q$  (Ah) is measured over each combined cycle according to the procedure in Appendix 3.2. to chapter 8 and used to determine when the battery minimum state of charge has been reached;



- 3.1.2.5.2.2.2. the battery minimum state of charge is considered to have been reached in combined cycle N if the electricity balance Q measured during combined cycle N+1 is not more than a 3 percent discharge, expressed as a percentage of the nominal capacity of the battery (in Ah) in its maximum state of charge, as declared by the manufacturer. At the manufacturer’s request, additional test cycles may be run and their results included in the calculations in clauses 3.1.2.5.5. and 3.1.4.2 of this Appendix, provided that the electricity balance Q for each additional test cycle shows less discharge of the battery than over the previous cycle;
- 3.1.2.5.2.2.3. after each cycle, a hot soak period of up to ten minutes is allowed. The power train shall be switched off during this period.
- 3.1.2.5.2.2.4 The weight of traction battery shall be ignored for the purpose of calculating the reference mass and inertia mass.
- 3.1.2.5.3. The vehicle shall be driven according to the provisions in Appendix 6 to chapter 2.
- 3.1.2.5.4. The exhaust gases shall be analyzed according to the provisions in chapter 2.
- 3.1.2.5.5. The test results shall be compared with the limits set out in the notification and the average emission of each pollutant (expressed in mg per kilometer) for Condition A shall be calculated ( $M_{1i}$  ).

In the case of testing according to clause 3.1.2.5.2.1. of this Appendix, ( $M_{1i}$  ) is the result of the specified driving cycle.

In the case of testing according to clause 3.1.2.5.2.2. of this Appendix, the test result of each combined cycle run ( $M_{1ia}$  ), multiplied by the appropriate deterioration factor and  $K_i$  factors, shall be less than the limits in the notification. For the purposes of the calculation in clause 3.1.4. of this Appendix,  $M_{1i}$  shall be defined as:

*Equation 1:*

$$M_{1i} = \frac{1}{N} \sum_{a=1}^N M_{1ia}$$

where:

$M_{1i}$ : Average emission of each pollutant

$i$ : Pollutant

$N$ : Number of cycles

$a$ : test cycle

- 3.1.3. **Condition B**
- 3.1.3.1. Conditioning of vehicle.  
The vehicle shall be conditioned by driving the applicable type I driving cycle as set out in Appendix 6 to chapter 2.
- 3.1.3.2. The electrical energy device/ REESS of the vehicle shall be discharged while driving (on the test track, on a chassis dynamometer, etc.):
- (a) at a steady speed of 50 km/h until the fuel-consuming engine starts up, or
  - (b) if a vehicle cannot reach a steady speed of 50 km/h without the fuel-consuming engine starting up, the speed shall be reduced until it can run at a lower steady speed at which the engine does not start up for a defined time or distance (to be determined by the test agency and the manufacturer), or
  - (c) in accordance with the manufacturers' recommendation
- The fuel-consuming engine shall be stopped within ten seconds of being automatically started
- 3.1.3.3. After this preconditioning and before testing, the vehicle shall be kept in a room in which the temperature remains relatively constant between 293.2 K and 303.2 K (20 °C and 30 °C). This conditioning shall be carried out for at least six hours and continue until the temperature of the engine oil and coolant, if any, are within  $\pm 2$  K of the temperature of the room.
- 3.1.3.4. Test procedure
- 3.1.3.4.1. The vehicle shall be started up by the means provided to the driver for normal use. The first cycle starts on the initiation of the vehicle start-up procedure
- 3.1.3.4.2. Sampling shall begin (BS) before or at the initiation of the vehicle start-up procedure and end on conclusion of the final idling period of the applicable type I test cycle (end of sampling (ES)).
- 3.1.3.4.3. The vehicle shall be driven according to the provisions of Appendix 6 to chapter 2.
- 3.1.3.4.4. The exhaust gases shall be analyzed in accordance with Chapter 2.
- 3.1.3.5. The test results shall be compared with the limits in the Notification GSR 889(E) and the average emission of each pollutant for Condition B shall be calculated ( $M_{2i}$ ). The test results  $M_{2i}$ , multiplied by the appropriate deterioration and  $K_i$  factors, shall be less than the limits prescribed in the notification GSR 889(E).

3.1.4. **Test results**

3.1.4.1. Testing in accordance with clause 3.1.2.5.2.1 of this Appendix.

For reporting, the weighted values shall be calculated as follows

Equation 2:

$$M_i = \frac{D_e M_{1i} + D_{av} M_{2i}}{D_e + D_{av}} \text{ (mg/km)}$$

where:

 $M_i$  = mass emission of the pollutant  $i$  in mg/km; $M_{1i}$  = average mass emission of the pollutant  $i$  in mg/km with a fully charged electrical energy device/REESS, calculated in accordance with clause 3.1.2.5.5 of this Appendix $M_{2i}$  = average mass emission of the pollutant  $i$  in mg/km with an electrical energy device/REESS in minimum state of charge (maximum discharge of capacity), calculated in accordance with clause 3.1.3.5 of this Appendix $D_e$  = electric range of the vehicle determined according to the procedure set out in Appendix 3.3. to Chapter 7, where the manufacturer shall provide the means for taking the measurement with the vehicle running in pure electric mode; $D_{av}$  = average distance between two battery recharges, as follows

- 25 km for a vehicle with an engine capacity < 150 cm<sup>3</sup>;
- 25 km for a vehicle with an engine capacity  $\geq$  150 cm<sup>3</sup> and  $v_{max} < 130$  km/h;
- 25 km for a vehicle with an engine capacity  $\geq$  150 cm<sup>3</sup> and  $v_{max} \geq 130$  km/h.

[**Note:**  $D_{av}$  is changed to align with AIS-102 and FAME incentive notification S.O.830(E)]

3.1.4.2. Testing in accordance with clause 3.1.2.5.2.2 of this Appendix.

For communication, reporting the weighted values shall be calculated as follows:

Equation 3:

$$M_i = \frac{D_{ovc} M_{1i} + D_{av} M_{2i}}{D_{ovc} + D_{av}}$$

where:

$M_i$  = mass emission of the pollutant  $i$  in mg/km;

$M_{1i}$  = average mass emission of the pollutant  $i$  in mg/km with a fully charged electrical energy device / REESS, calculated in accordance with clause 3.1.2.5.5. of this Appendix;

$M_{2i}$  = average mass emission of the pollutant  $i$  in mg/km with an electrical energy device / REESS in minimum state of charge (maximum discharge of capacity), calculated in accordance with clause 3.1.3.5. of this Appendix;

$D_{OVC}$  = OVC range established in accordance with the procedure in Appendix 3.3. to Chapter 8;

$D_{av}$  = average distance between two battery recharges, as follows:

- 25 km for a vehicle with an engine capacity  $< 150 \text{ cm}^3$  ;
- 25km for a vehicle with an engine capacity  $\geq 150 \text{ cm}^3$  and  $v_{max} < 130 \text{ km/h}$ ;
- 25 km for a vehicle with an engine capacity  $\geq 150 \text{ cm}^3$  and  $v_{max} \geq 130 \text{ km/h}$ .

[**Note:**  $D_{av}$  is changed to align with AIS-102 and FAME incentive notification S.O.830(E)]

**3.2. Externally chargeable vehicles (OVC HEVs) with an operating mode switch.**

3.2.1. Two tests shall be performed under the following conditions

3.2.1.1. Condition A: the test shall be carried out with a fully charged electrical energy device/REESS.

3.2.1.2. Condition B: the test shall be carried out with an electrical energy device/REESS in minimum state of charge (maximum discharge of capacity).

3.2.1.3. The operating mode switch shall be positioned in accordance with the table 2 of this Appendix.

**Table 2**

**Look-up table to determine Condition A or B depending on different hybrid vehicle concepts and on the hybrid mode selection switch position**

	Hybrid Modes			
	— Pure electric — Hybrid	— Pure fuel-consuming — Hybrid	— Pure electric — Pure fuel-consuming — Hybrid	— Hybrid mode n <sup>(1)</sup> — Hybrid mode m <sup>(1)</sup>
<b>Battery state of charge</b>	<b>Switch in position</b>	<b>Switch in position</b>	<b>Switch in position</b>	<b>Switch in position</b>
<b>Condition A Fully charged</b>	Hybrid	Hybrid	Hybrid	Most electric Hybrid Mode <sup>(2)</sup>
<b>Condition B Min. state of charge</b>	Hybrid	Fuel-consuming	Fuel-consuming	Most fuel consuming Mode <sup>(3)</sup>

<sup>(1)</sup> For instance: sport, economic, urban, extra-urban position, etc.

<sup>(2)</sup> Most electric hybrid mode: the hybrid mode which can be proven to have the highest electricity consumption of all selectable hybrid modes when tested in accordance with condition A of Clause 4 of Annex 10 to UNECE Regulation No 101, to be established based on information provided by the manufacturer and in agreement with the test agency.

<sup>(3)</sup> Most fuel-consuming mode: the hybrid mode which can be proven to have the highest fuel consumption of all selectable hybrid modes when tested in accordance with condition B of Clause 4 of Annex 10 to UNECE Regulation No 101, to be established based on information provided by the manufacturer and in agreement with the test agency.

**3.2.2. Condition A**

3.2.2.1. If the pure electric range of the vehicle is higher than one complete cycle, the type I test may at the manufacturer’s request be carried out in pure electric mode. On the request of the manufacturer, the Type I test for condition A may not be carried out.

In such cases, the value of M1i shall be taken as zero for calculation of final results

3.2.2.2. The procedure shall start with the discharge of the electrical energy device/REESS of the vehicle while driving with the switch in pure electric position (on the test track, on a chassis dynamometer, etc.) at a steady speed of 70 percent  $\pm$  5 percent of the maximum design speed of the vehicle, as per IS 10278.

Stopping the discharge occurs in any of the following conditions:

- (a) when the vehicle is not able to run at 65 percent of the maximum thirty minutes speed;
- (b) when the standard on-board instrumentation gives the driver an indication to stop the vehicle;
- (c) after 100 km.

If the vehicle is not equipped with a pure electric mode, the electrical energy device/REESS shall be discharged by driving the vehicle (on the test track, on a chassis dynamometer, etc.) in any of the following conditions:

- (a) at a steady speed of 50 km/h until the fuel-consuming engine of the HEV starts up;
- (b) if a vehicle cannot reach a steady speed of 50 km/h without the fuel-consuming engine starting up, the speed shall be reduced until it can run at a lower steady speed at which the fuel-consuming engine does not start up for a defined time or distance (to be determined by the test agency and the manufacturer);
- (c) in accordance with the manufacturers' recommendation.

The fuel-consuming engine shall be stopped within ten seconds of being automatically started. By means of derogation if the manufacturer can prove to the test agency that the vehicle is physically not capable of achieving the thirty minutes speed the maximum fifteen minute speed may be used instead.

3.2.2.3. Conditioning of vehicle

3.2.2.4. After this preconditioning and before testing, the vehicle shall be kept in a room in which the temperature remains relatively constant between (20 °C and 3 °C). This conditioning shall be carried out for at least six hours and continue until the temperature of the engine oil and coolant, if any, are within  $\pm$  2 K of the temperature of the room, and the electrical energy device/REESS is fully charged as a result of the charging prescribed in clause 3.2.2.5 of this Appendix.

3.2.2.5. During soak, the electrical energy/power storage device shall be charged with any of the following chargers

- (a) the on-board charger if fitted;
- (b) an external charger recommended by the manufacturer, using the normal overnight charging procedure.

This procedure excludes all types of special charges that could be automatically or manually initiated, e.g. equalization charges or servicing charges.

The manufacturer shall declare that a special charge procedure has not occurred during the test

- (c) End-of-charge criterion

The end-of-charge criterion corresponds to a charging time of 12 hours, except where the standard instrumentation gives the driver a clear indication that the electrical energy storage device is not yet fully charged

In this case, the maximum time is  $= 3 \times \text{claimed battery capacity (Wh)} / \text{mains power supply (W)}$ .

3.2.2.6. Test procedure

3.2.2.6.1. The vehicle shall be started up by the means provided to the driver for normal use. The first cycle starts on the initiation of the vehicle start-up procedure.

3.2.2.6.1.1. Sampling shall begin (BS) before or at the initiation of the vehicle start-up procedure and end on conclusion of the final idling period of the applicable type I test cycle (end of sampling (ES))

3.2.2.6.1.2. Sampling shall begin (BS) before or at the initiation of the vehicle start-up procedure and continue over a number of repeat test cycles. It shall end on conclusion of the final idling period of the applicable type I test cycle during which the battery has reached the minimum state of charge in accordance with the following procedure (end of sampling (ES))

3.2.2.6.1.2.1. The electricity balance  $Q$  (Ah) is measured over each combined cycle using the procedure in Appendix 3.2. to chapter 8 and used to determine when the battery minimum state of charge has been reached;

3.2.2.6.1.2.2. The battery minimum state of charge is considered to have been reached in combined cycle  $N$  if the electricity balance measured during combined cycle  $N+1$  is not more than a 3 percent discharge, expressed as a percentage of the nominal capacity of the battery (in Ah) in its maximum state of charge, as declared by the manufacturer. At the manufacturer's request, additional test cycles

may be run and their results included in the calculations in clause 3.2.2.7. and 3.2.4.3. of this Appendix, provided that the electricity balance for each additional test cycle shows less discharge of the battery than over the previous cycle;

- 3.2.2.6.1.2.3. After each cycle, a hot soak period of up to ten minutes is allowed. The powertrain shall be switched off during this period
- 3.2.2.6.2. The vehicle shall be driven according to the provisions of Appendix 6 to chapter 2.
- 3.2.2.6.3. The exhaust gases shall be analysed according to Chapter 2.
- 3.2.2.7. The test results shall be compared to the emission limits set out in the notification G.S.R.889(E) and the average emission of each pollutant (expressed in mg/km) for Condition A shall be calculated ( $M_{1i}$ ).

The test result of each combined cycle run  $M_{1ia}$ , multiplied by the appropriate deterioration and  $K_i$  factors, shall be less than the emission limits as per notification. For the purposes of the calculation in clause 3.2.4. of this Appendix,  $M_{1i}$  shall be calculated according to Equation 1 of this Appendix.

**3.2.3. Condition B**

**3.2.3.1. Conditioning of vehicle.**

The vehicle shall be conditioned by driving the applicable type I driving cycle set out in Appendix 6 to chapter 2.

- 3.2.3.2. The electrical energy device/REESS of the vehicle shall be discharged in accordance with clause 3.2.2.2 of this Appendix.

- 3.2.3.3. After this preconditioning, and before testing, the vehicle shall be kept in a room in which the temperature remains relatively constant between (20 °C and 30 °C). This conditioning shall be carried out for at least six hours and continue until the temperature of the engine oil and coolant, if any, are within  $\pm 2^0\text{C}$  of the temperature of the room.

**3.2.3.4. Test procedure**

- 3.2.3.4.1. The vehicle shall be started up by the means provided to the driver for normal use. The first cycle starts on the initiation of the vehicle start-up procedure.
- 3.2.3.4.2. Sampling shall begin (BS) before or at the initiation of the vehicle start-up procedure and end on conclusion of the final idling period of the applicable type I test cycle (end of sampling (ES)).



- 3.2.3.4.3. The vehicle shall be driven in accordance with the provisions of Appendix 6 to chapter 2.
- 3.2.3.4.4. The exhaust gases shall be analysed in accordance with the provisions in chapter 2.
- 3.2.3.5. The test results shall be compared with the pollutant limits in the notification G.S.R. 889(E) and the average emission of each pollutant for Condition B shall be calculated ( $M_{2i}$ ). The test results  $M_{2i}$ , multiplied by the appropriate deterioration and  $K_i$  factors, shall be less than the notified limits.
- 3.2.4. **Test results**
  - 3.2.4.1. Testing in accordance with clause 3.2.2.6.2.1 of this Appendix  
  
For reporting, the weighted values shall be calculated as in Equation 2 of this Appendix
  - 3.2.4.2. Testing in accordance with clause 3.2.2.6.2.2 of this Appendix.  
  
For reporting, the weighted values shall be calculated as in Equation 3 of this Appendix
- 3.3. **Not externally chargeable vehicles (not-OVC HEVs) without an operating mode switch**
  - 3.3.1. These vehicles shall be tested according to Appendix 6 to chapter 2.
  - 3.3.2. For preconditioning, at least two consecutive complete driving cycles are carried out without soak.
  - 3.3.3. The vehicle shall be driven in accordance with to the provisions of Appendix 6 to chapter 2.
- 3.4. **Not externally chargeable vehicles (not-OVC HEVs) with an operating mode switch**
  - 3.4.1. These vehicles are preconditioned and tested in hybrid mode in accordance with Chapter 2. If several hybrid modes are available, the test shall be carried out in the mode that is automatically set after the ignition key is turned (normal mode). On the basis of information provided by the manufacturer, the test agency shall ensure that the limit values are complied with in all hybrid modes
  - 3.4.2. For preconditioning, at least two consecutive complete applicable driving cycles shall be carried out without soak.
  - 3.4.3. The vehicle shall be driven in accordance with the provisions of Chapter 2.

**CHAPTER 3****TEST TYPE II REQUIREMENTS - TAILPIPE EMISSIONS  
AT IDLING AND FREE ACCELERATION****1.0 INTRODUCTION**

This Chapter describes the test procedure for Type II testing for verification of compliance to applicable provisions of CMV Rule No. 115 (2).

**2.0 SCOPE**

2.1 Vehicles equipped with a propulsion type of which a positive ignition combustion engine forms a part shall be subject only to a Type II emission test as set out in clauses 3, 4 and 5 of this Chapter.

2.2 Vehicles equipped with a propulsion type of which a compression ignition combustion engine forms a part shall be subject only to a Type II free acceleration emission test as set out in clauses 3, 6 of this Chapter. In this case clause 3.8 of this Chapter is not applicable.

**3.0 GENERAL CONDITIONS OF TYPE II EMISSION TESTING**

3.1 In general practice, Type II test shall be carried out immediately after Type I test, if not, A visual inspection of any emission control equipment shall be conducted prior to start of the type II emission test in order to check that the vehicle is complete, in a satisfactory condition and that there are no leaks in the fuel, air supply or exhaust systems. If the testing is done immediately after the Type I test, these inspections may not be carried out.

3.2 The fuel used to conduct the Type II tests shall be the reference fuel, as specified in the notification. In case the engine is lubricated by mixing oil to the fuel, the quality and quantity of lubricating oil shall be as prescribed by the manufacturer.

3.3 During the test, the environmental temperature shall be between 293.2 K and 303.2 K (20 °C and 30 °C).

3.4 In the case of vehicles with manually-operated or semi-automatic-shift gearboxes, the test Type II test shall be carried out with the gear lever in the 'neutral' position and the clutch engaged.

3.5 In the case of vehicles with automatic-shift gearboxes, the idle Type II test shall be carried out with the gear selector in either the 'neutral' or the 'park' position. Where an automatic clutch is also fitted, the driven axle shall be lifted up to a clause at which the wheels can rotate freely.

3.6 The Type II emission test shall be conducted immediately after the Type I emission test. In any event, if Type-II test is required to be conducted independent of Type-I test then the engine shall be warmed up to ensure the conditions as observed at the end of Type-I test.

- 3.7 The exhaust outlets shall be provided with an air-tight extension, so that the sample probe used to collect exhaust gases may be inserted at least 300 mm into the exhaust outlet without increasing the back pressure of more than 125 mm H<sub>2</sub>O and without disturbing operation of the vehicle. This extension shall be so shaped as to avoid any appreciable dilution of exhaust gases in the air at the location of the sample probe. Where a vehicle is equipped with an exhaust system with multiple outlets, either these shall be joined to a common pipe or the pollutants shall be collected from each of them and an arithmetical average taken.
- 3.8 The emission test equipment and analysers to perform the Type II testing shall be regularly calibrated and maintained. A flame ionisation detection or NDIR analyser may be used for measuring hydrocarbons.
- 3.9 The vehicles shall be tested with the fuel-consuming engine running.
- 3.9.1 For hybrid applications or applications equipped with a stop-start system, the manufacturer shall install on the vehicle a 'service mode' that makes it possible to inspect the vehicle for Type II tests on a running fuel-consuming engine, in order to determine its performance in relation to the data collected. Where this inspection requires a special procedure, this shall be detailed in the service manual (or equivalent media). That special procedure shall not require the use of special equipment other than that provided with the vehicle.

**4.0 TEST TYPE II – DESCRIPTION OF TEST PROCEDURE TO MEASURE TAILPIPE EMISSIONS AT IDLE AND FREE ACCELERATION**

The test shall be carried out with the engine at normal idling speed as specified by the manufacturer. The Type II idle test shall be considered acceptable if the values measured are within the applicable limits prescribed in CMV Rule No. 115 (2 )

- 4.1 Components for adjusting the idling speed
- In case where vehicle is having Components for adjusting the idling speed then measurement of Type II test immediately after Type I is not possible needs to be carried out after completion of test sequence (V1, V2 & V3).
- 4.1.1 Components for adjusting the idling speed for the purposes of this Chapter refer to controls for changing the idling conditions of the engine which may be easily operated by a mechanic using only the tools referred to in clause 4.1.2 of this Chapter. In particular, devices for calibrating fuel and air flows are not considered as adjustment components if their setting requires the removal of the set-stops, an operation which can normally be performed only by a Trained mechanic.

- 4.1.2 The tools which may be used to adjust the idling speed are screwdrivers (ordinary or cross-headed), spanners (ring, open-end or adjustable), pliers, Allen keys and a generic scan tool.
- 4.2 Determination of measurement clauses and Type II idle test pass/fail criteria
  - 4.2.1 First, a measurement is taken at the setting in accordance with the conditions fixed by the manufacturer
  - 4.2.2 For each adjustment component with a continuous variation, a sufficient number of characteristic positions shall be determined. The test shall be carried out with the engine at 'normal idling speed' and at 'high idle speed'. The definition of the possible position of the adjustment components to a just 'Normal idling speed' is defined under clause 4.2.5 of this Chapter. High idle engine speed is defined by the manufacturer but it must be higher than  $2500 \pm 200 \text{ min}^{-1}$ . The high idle speed is reached and kept stable by manually operating the throttle pedal or throttle handle
  - 4.2.3 The measurement of the pollutants content of exhaust gases shall be carried out for all the possible positions of the adjustment components, but for components with a continuous variation only for the positions referred to in clause 4.2.2 of this Chapter.
  - 4.2.4 The Type II idle test shall be considered passed if the following condition is met:
    - 4.2.4.1 The maximum pollutant content shall not exceed the notified limits.
  - 4.2.5 The possible positions of the adjustment components shall be limited by any of the following:
    - 4.2.5.1 the larger of the following two values:
      - (a) the lowest idling speed which the engine can reach;
      - (b) the speed recommended by the manufacturer, minus 100 revolutions per minute;
    - 4.2.5.2 the smallest of the following three values:
      - (a) the highest rotation speed which the crankshaft of the engine can attain by activation of the idling speed components;
      - (b) the rotation speed recommended by the manufacturer, plus 250 revolutions per minute;
      - (c) the cut-in rotation speed of automatic clutches

- 4.2.6 Settings incompatible with the correct running of the engine shall not be adopted as measurement settings. In particular, if the engine is equipped with several carburettors, all the carburettors shall have the same setting.
- 4.3 The following parameters shall be measured and recorded at normal idling speed and at high idle speed, as per Notification:
- (a) the carbon monoxide (CO) content by volume of the exhaust gases emitted (in vol %);
  - (b) the carbon dioxide (CO<sub>2</sub>) content by volume of the exhaust gases emitted (in vol %);
  - (c) hydrocarbons (HC) in ppm (n-hexane);
  - (d) the oxygen (O<sub>2</sub>) content by volume of the exhaust gases emitted (in vol %) or lambda, as chosen by the manufacturer;
  - (e) the engine speed during the test, including any tolerances;
  - (f) the engine oil temperature at the time of the test. Alternatively, for liquid cooled engines, the coolant temperature shall be acceptable.
- 4.3.1 With respect to the parameters under clause 4.3. (d) of this Chapter (O<sub>2</sub>/lambda) the following shall apply
- 4.3.1.1 The measurement shall only be conducted at high idle engine speed;
  - 4.3.1.2 Vehicles in the scope of this measurement are only those equipped with a closed loop fuel system
  - 4.3.1.3 Exemptions for vehicle with:
    - 4.3.1.3.1 Engines equipped with a mechanically-controlled (spring, vacuum) secondary air system;
    - 4.3.1.3.2 Two - stroke engines operated on a mix of fuel and lubrication oil.

## **5.0 CO CONCENTRATION CALCULATION IN THE TYPE II IDLE TEST**

The sampling probe shall be inserted into the exhaust pipe to a depth of at least 300 mm into the pipe connecting the exhaust with the sampling bag and as close as possible to the exhaust.

- 5.1 The CO ( $C_{CO}$ ) and CO<sub>2</sub> ( $C_{CO_2}$ ) concentration shall be determined from the measuring instrument readings or recordings, by use of appropriate calibration curves.

5.2 The corrected concentration for carbon monoxide is:

For four stroke engine

Equation 1

$$C_{CO_{corr}} = 15 * \frac{C_{CO}}{C_{CO} + C_{CO_2}}$$

For two stroke engine:

Equation 2

$$C_{CO_{corr}} = 10 * \frac{C_{CO}}{C_{CO} + C_{CO_2}}$$

**Note:** During calculation if the correction factor is less than 1, then it will be treated as 1.

5.3 The  $C_{CO}$  concentration (see clause 5.1 of this Chapter.) shall be measured in accordance with the formulae in clause 5.2 of this Chapter and does not need to be corrected if the total of the concentrations measured ( $C_{CO} + C_{CO_2}$ ) is at least:

- (a) for petrol(E5): 15 percent;
- (b) for LPG: 13.5 percent;
- (c) for NG/bio methane: 11.5 percent.

## 6.0 TEST TYPE II – FREE ACCELERATION TEST PROCEDURE

6.1 The combustion engine and any turbocharger or supercharger, if fitted, shall be running at idle before start of each free acceleration test cycle.

6.2 To initiate each free acceleration cycle, the throttle pedal/accelerator shall be applied gradually but not violently to reach full throttle operating condition within 5 seconds, so as to obtain maximum delivery from the fuel pump.

6.3 During each free acceleration cycle, the engine shall reach cut-off speed or, for vehicles with automatic transmissions, the speed specified by the manufacturer or, if this data is not available, two-thirds of the cut-off speed, before the throttle is released. This could be checked, for instance, by monitoring engine speed or by allowing at least two seconds elapsing between initial throttle depression and release.

6.4 For vehicles equipped with CVT and automatic clutch, the driven wheels may be lifted from the ground. For engines with safety limits in the engine control (e.g. max 1500 rpm without running wheels or without gear engaged), this maximum engine speed shall be reached.

6.5 The average concentration level of the opacity (in  $\text{m}^{-1}$ ) in the exhaust flow (opacity) shall be measured during five free acceleration tests. Opacity means an optical measurement of the density of particulate matter in the exhaust flow of an engine, expressed in  $\text{m}^{-1}$ . Time duration between the two consecutive free accelerations tests shall be 5 to 20 seconds

**7.0 TEST TYPE II – FREE ACCELERATION TEST RESULTS AND REQUIREMENTS**

7.1 The test value measured in accordance with clause 6.5 of this Chapter shall be in compliance with the requirements laid down in CMV Rule No. 115 (2).

**8.0 COP PROCEDURE – TECHNICAL REQUIREMENTS**

8.1 COP test procedure for Type II test shall be as per clause 6.0 of Appendix 11 to Chapter 2.

**CHAPTER 4****TYPE III TESTS-EMISSIONS OF CRANKCASE GASES****TYPE IV TESTS – EVAPORATIVE EMISSIONS.****1.0 PURPOSE**

This Chapter provides harmonized test methods for the determination of crankcase gas emissions (Test Type III).

This Chapter also provides test procedures to determine evaporative emissions (Test Type IV) owing to evaporation of fuel through the vehicle's fuel tank and fuel delivery system.

**2.0 SCOPE AND APPLICATION**

2.1 Vehicles covered in the scope with regard to the propulsion unit and fuel type in accordance with Table 2 of sub-rule-19(i) of the notification.

**3.0 DEFINITIONS: REFER OVERALL REQUIREMENTS****4.0 LIST OF ACRONYMS AND SYMBOLS: REFER APPENDIX 1 TO CHAPTER 2****5.0 GENERAL REQUIREMENTS**

5.1 Vehicles, systems, and components shall be so designed, constructed and assembled by the manufacturer, so as to enable the vehicle, in normal use and maintained according to the prescriptions of the manufacturer, to comply with the provisions of this Chapter during its useful life.

**6.0 TEST TYPE III REQUIREMENTS: EMISSIONS OF CRANKCASE GASES****6.1 INTRODUCTION**

6.1.1 Test type III shall be conducted in order to demonstrate that zero emissions from the crankcase and/or if applicable the crankcase ventilation system can escape directly into the atmosphere.

**6.2 General provisions**

6.2.1 Zero emissions from the crankcase and/or if applicable the crankcase ventilation system may escape directly into the atmosphere from any vehicle throughout its useful life. For this purpose test agency may require:

6.2.1.1 A written declaration from the vehicle manufacturer that the propulsion unit is equipped with a closed crankcase system preventing crankcase gas to be discharged directly into the ambient atmosphere



6.2.2 The manufacturer shall provide the test agency with technical details and drawings to prove that the engine or engines are so constructed as to prevent vapour of any fuel, lubrication oil or crankcase gases from escaping to the atmosphere from the crankcase gas ventilation system.

6.2.3 A physical verification may be conducted that the crankcase breather is not let out into atmosphere but is connected to the Intake system.

6.2.4 Type III test is not applicable for vehicles equipped with a two-stroke engine containing a scavenging port between the crank case and the cylinder(s).

## **7.0 TEST TYPE IV REQUIREMENTS: EVAPORATIVE EMISSIONS**

### **7.1. Introduction – evaporative emissions**

7.1.1 The procedure laid down in Appendix 3 sets out the evaporative hydrocarbon emission determination requirements of the whole vehicle.

### **7.2. General requirements**

#### **7.2.1 Test fuel**

The appropriate test fuel, as defined in sub-rule (19(i)) of the notification shall be used.

7.2.1.1 If the combustion engine uses a petrol-lubrication oil mixture, the lubrication oil added to the reference fuel shall comply with the grade and quantity recommended by the manufacturer.

### **7.3 Durability**

As an alternate to fixed deterioration factor mentioned in 2.1.1 of Appendix 1 of this Chapter, the manufacturer may demonstrate the durability of the evaporative emission control system using the applicable durability test procedure as per clause 2.1.2 of Appendix 1 of this Chapter.

### **7.4 Documentation**

The vehicle manufacturer shall fill out the information document in accordance with the evaporative emission test parameters laid down in AIS-007 and submit it to the test agency.

**APPENDIX 1 TO CHAPTER 4**

**Sealed Housing for Evaporation Determination (SHED) test procedure**

**1.0 DESCRIPTION OF SHED TEST**

The evaporative emission SHED test (Figure 1 of this Appendix) consists of a conditioning phase and a test phase, as follows:

- (a) conditioning phase:
  - (i) driving cycle;
  - (ii) vehicle soak;
- (b) test phase:
  - (i) diurnal (breathing loss) test;
  - (ii) driving cycle;
  - (iii) hot soak loss test.

Mass emissions of hydrocarbons from the tank breathing loss and the hot soak loss phases are added together to provide an overall result for the test.

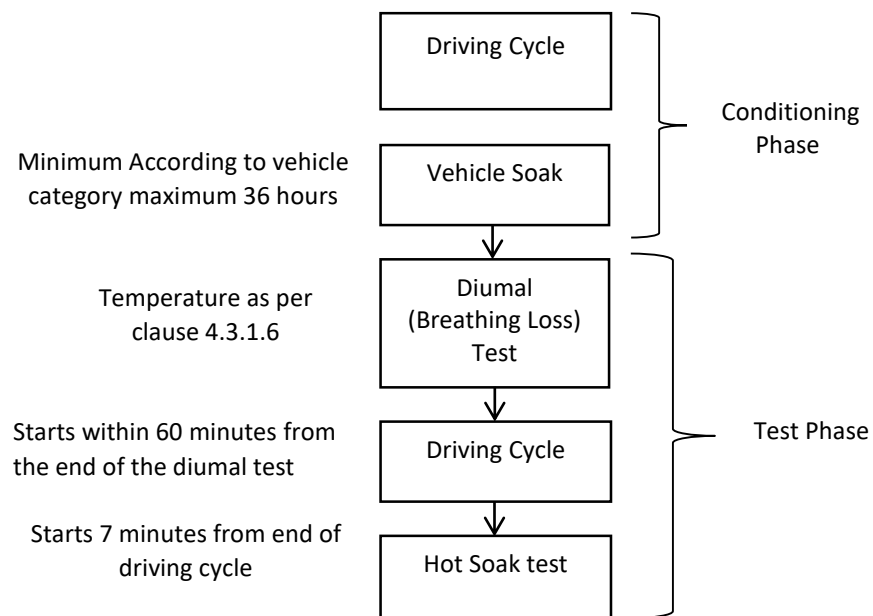

**Figure 1**

**Flow Chart – SHED test procedure**

## **2.0 TEST VEHICLE REQUIREMENT**

### **2.1 Durability**

The SHED test shall be conducted at the choice of the manufacturer with one or more degreened test vehicle(s) equipped with:

- 2.1.1 degreened emission control devices. The appropriate procedure to run-in these devices shall be left to the choice of the manufacturer under the condition that the test procedure to "degreen" the devices is reported in detail and evidence is provided that this test procedure is actually followed.

A fixed deterioration factor of 300 mg/test shall be added to the SHED test result, **or**

- 2.1.2 Aged evaporative emission control devices. The ageing test procedure set-out in Appendix 2 shall apply.

### **2.2 Test vehicles**

The degreened test vehicle, which shall be representative of the vehicle type with regard to environmental performance to be approved, shall be in good mechanical condition and, before the evaporative test, have been run in and driven at least 1000 km after first start on the production line. The evaporative emission control system shall be connected and functioning correctly over this period and the carbon canister<sup>1</sup> and evaporative emission control valve subjected to normal use, undergoing neither abnormal purging nor abnormal loading.

<sup>(1)</sup> Or the canister with HC absorbent material or other equivalent.

## **3.0 CHASSIS DYNAMOMETER AND EVAPORATIVE EMISSIONS ENCLOSURE**

- 3.1 **The chassis dynamometer shall meet the requirements of Appendix 3 to Chapter 2.**

### **3.2 Evaporative emission measurement enclosure (SHED)**

The evaporative emission measurement enclosure shall be a gas-tight rectangular measuring chamber able to contain the vehicle under test. The vehicle shall be accessible from all sides when inside and the enclosure when sealed shall be gas-tight. The inner surface of the enclosure shall be impermeable to hydrocarbons. At least one of the surfaces shall incorporate a flexible impermeable material or other device to allow the equilibration of pressure changes resulting from small changes in temperature. Wall design shall be such as to promote good dissipation of heat.

### 3.3 Analytical systems

#### 3.3.1 Hydrocarbon analyzer

3.3.1.1 The atmosphere within the chamber is monitored using a hydrocarbon detector of the flame ionization detector (FID) type. Sample gas shall be drawn from the midpoint of one side wall or the roof of the chamber and any bypass flow shall be returned to the enclosure, preferably to a point immediately downstream of the mixing fan.

3.3.1.2 The hydrocarbon analyzer shall have a response time to 90 percent of final reading of less than 1.5 seconds. Its stability shall be better than 2 percent of full scale at zero and at  $80 \pm 20$  percent of full scale over a 15-minute period for all operational ranges.

3.3.1.3 The repeatability of the analyzer expressed as one standard deviation shall be better than 1 percent of full scale deflection at zero and at  $80 \pm 20$  percent of full scale on all ranges used.

3.3.1.4 The operational ranges of the analyzer shall be chosen to give best resolution over the measurement, calibration and leak-checking procedures.

#### 3.3.2 Hydrocarbon analyzer data recording system

3.3.2.1 The hydrocarbon analyzer shall be fitted with a device to record electrical signal output either by strip chart recorder or other data-processing system at a frequency of at least once per minute. The recording system shall have operating characteristics at least equivalent to the signal being recorded and shall provide a permanent record of results. The record shall show a positive indication of the beginning and end of the fuel tank heating and hot soak periods together with the time elapsed between start and completion of each test.

### 3.4 Fuel tank heating

3.4.1 The fuel tank heating system shall consist of at least two separate heat sources with two temperature controllers. A typical heat source shall be a pair of heating pads. Other heat sources may be used as required by the circumstances at the request of the manufacturer to the satisfaction of the test agency. Temperature controllers may be manual, such as variable transformers, or they may be automated. Since vapour and fuel temperature are to be controlled separately, an automatic controller is recommended both for the fuel and the vapour.

3.4.2 The heating system shall not cause hot-spots on the wetted surface of the tank which would cause local overheating of the fuel. Heating pads, for the fuel if used, shall be located as low as practicable on the fuel tank and shall cover at least 10 percent of the wetted surface. The centre line of the fuel heating strips if used shall be below 30 percent of the fuel depth as measured from the bottom of the fuel tank, and approximately parallel to the fuel level in the tank. The centre line of the vapour heating strips,

if used, shall be located at the approximate height of the centre of the vapour volume. The temperature controllers shall be capable of controlling the fuel and vapour temperatures to the heating function laid down in clause 4.3.1.6. of this Appendix.

3.4.3 In order to ensure uniform and appropriate heating and measurement of temperature for fuel and vapour the following precautions or the manufacturer recommendations shall be followed:

- a) Separate heating pads for fuel and vapour shall cover as much area as possible;
- b) The pasting of heating pads on either side of fuel tank shall be symmetric for fuel and vapour heating.
- c) The position of fuel and vapour temperature sensors shall be as close to the area covered by heating pads respectively;
- d) No fuel heating pad shall be located above a 40 percent volume fill line from bottom. Likewise no vapour heating pad for the tank evaporative test shall be below the 60 percent volume fill line from bottom.

Example fuel tank with appropriate positioning of fuel tank heating pads to control fuel and vapour temperatures.

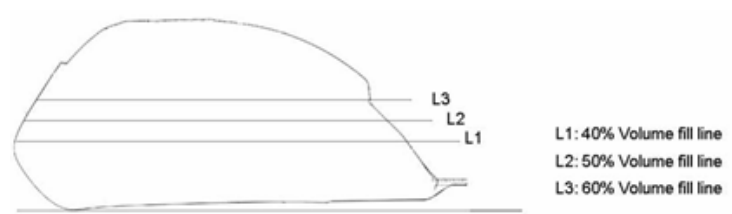

**Figure 2**

3.4.4 With temperature sensors positioned as in clause 3.5.2 of this Appendix, the fuel heating device shall make it possible to evenly heat the fuel and fuel vapour in the tank in accordance with the heating function described in Clause 4.3.1.6 of this Appendix. The heating system shall be capable of controlling the fuel and vapour temperatures to  $\pm 1.7^{\circ}\text{C}$  of the required temperature during the tank heating process.

3.4.5 Notwithstanding the requirements of clause 3.4.2 of this Appendix, if a manufacturer is unable to meet the heating requirement specified, due to use of thick-walled plastic fuel tanks for example, then the closest possible alternative heat slope shall be used. Prior to the commencement of any test, manufacturers shall submit engineering data to the test agency to support the use of an alternative heat slope.

### 3.5 **Temperature recording**

3.5.1 The temperature in the chamber is recorded at two points by temperature sensors which are connected so as to show a mean value. The measuring points are extended approximately 0.1 m into the enclosure from the vertical centre line of each side wall at a height of  $0.9 \pm 0.2$  m.

- 3.5.2 The temperatures of the fuel and fuel vapour shall be recorded by means of sensors positioned in the fuel tank so as to measure the temperature of the prescribed test fuel at the approximate mid-volume of the fuel. In addition, the vapour temperature in the fuel tank shall be measured at the approximate mid-volume of the vapour
- 3.5.3 When the fuel or vapour temperature sensors cannot be located in the fuel tank to measure the temperature of the prescribed test fuel or vapour at the approximate mid-volume, sensors shall be located at the approximate mid-volume of each fuel or vapour containing cavity. The average of the readings from these sensors shall constitute the fuel or vapour temperature. The fuel and vapour temperature sensors shall be located at least one inch away from any heated tank surface. The test agency may approve alternate sensor locations where the specifications above cannot be met or where tank symmetry provides redundant measurements.
- 3.5.4 Throughout the evaporative emission measurements, temperatures shall be recorded or entered into a data processing system at a frequency of at least once per minute.
- 3.5.5 The accuracy of the temperature recording system shall be within  $\pm 1.7$  K /  $\pm 1.7$  °C and capable of resolving temperatures to 20°C.
- 3.5.6 The recording or data processing system shall be capable of resolving time to  $\pm 15$  seconds.
- 3.6 **Fans**
- 3.6.1 It shall be possible to reduce the hydrocarbon concentration in the chamber to the ambient hydrocarbon level by using one or more fans or blowers with the SHED door(s) open.
- 3.6.2 The chamber shall have one or more fans or blowers of likely capacity 0.1 to 0.5 m<sup>3</sup>/s with which it is possible to thoroughly mix the atmosphere in the enclosure. It shall be possible to attain an even temperature and hydrocarbon concentration in the chamber during measurements. The vehicle in the enclosure shall not be subjected to a direct stream of air from the fans or blowers.
- 3.7 **Gases**
- 3.7.1 The following pure gases shall be available for calibration and operation:
- a) purified synthetic air (purity: < 1 ppm C<sub>1</sub> equivalent <1 ppm CO, < 400 ppm CO<sub>2</sub>, 0.1 ppm NO); oxygen content between 18 and 21 percent by volume;
  - b) hydrocarbon analyzer fuel gas (40  $\pm$  2 percent hydrogen, and balance helium with less than 1 ppm C<sub>1</sub> equivalent hydrocarbon, less than 400 ppm CO<sub>2</sub>);
  - c) Propane (C<sub>3</sub>H<sub>8</sub>), 99.5 percent minimum purity.

3.7.2 Calibration and span gases shall be available containing mixtures of propane ( $C_3H_8$ ) and purified synthetic air. The true concentrations of a calibration gas shall be within  $\pm 2$  percent of the stated figures. The accuracy of the diluted gases obtained when using a gas divider shall be to within  $\pm 2$  percent of the true value. The concentrations specified in Clause 3.7.1 may also be obtained by the use of a gas divider using synthetic air as the diluting gas. The FID analyzer shall be calibrated using air/propane or air/hexane mixtures with nominal hydrocarbon concentrations equal to 50 percent and 90 percent of full scale.

### 3.8 **Additional equipment**

3.8.1 The relative humidity in the test area shall be measurable to within  $\pm 5$  percent.

3.8.2 The pressure within the test area shall be measurable to within  $\pm 0.1$  kPa.

### 3.9 **Alternative equipment**

3.9.1 At the request of the manufacturer and with the agreement of the test agency, the test agency may authorize the use of alternative equipment provided that it can be demonstrated that it gives equivalent results.

## 4.0 **TEST PROCEDURE**

### 4.1 **Test preparation**

4.1.1 The vehicle is mechanically prepared before the test as follows:

- a) the exhaust system of the vehicle shall not exhibit any leaks;
- b) the vehicle may be steam-cleaned before the test;
- c) the fuel tank of the vehicle shall be equipped with temperature sensors so that the temperature of the fuel and fuel vapour in the fuel tank can be measured when it is filled to 50 percent  $\pm 2$  percent of its capacity declared by the manufacturer;
- d) Additional fittings, adaptors or devices may optionally be fitted to allow a complete draining of the fuel tank. Alternatively, the fuel tank may be evacuated by means of a pump or siphon that prevents fuel spillage.

### 4.2 **Conditioning phase**

4.2.1. The vehicle shall be taken into the test area where the ambient temperature is between 20°C and 30°C.

4.2.2 Before switching off the engine, the test vehicle is placed on a chassis dynamometer and driven a single time through the applicable Type I test cycle as specified in (Appendix 6 to Chapter 2).

4.2.3 The vehicle is parked in the test area for the minimum period stated in Table1 of Appendix 4 of this chapter.

Table 1

**SHED test – minimum and maximum soak periods**

Engine capacity	Minimum (hours)	Maximum (hours)
< 170 cm <sup>3</sup>	6	36
170 cm <sup>3</sup> ≤ engine capacity < 280 cm <sup>3</sup>	8	36
≥ 280 cm <sup>3</sup>	12	36

4.3 **Test phases**

## 4.3.1 Tank breathing (diurnal) evaporative emission test

4.3.1.1 The measuring chamber shall be vented/purged for several minutes immediately before the test until a stable background is obtainable. The chamber mixing fan(s) shall be switched on at this time also.

4.3.1.2 The hydrocarbon analyzer shall be set to zero and spanned immediately before the test.

4.3.1.3 The fuel tank(s) shall be emptied as described in clause 4.1.1 of this Appendix and refilled with test fuel at a temperature of between 10<sup>0</sup>C and 14<sup>0</sup>C to 50 percent ± 2 percent of the capacity declared by the manufacturer.

4.3.1.4 The test vehicle shall be brought into the test enclosure with the engine switched off and parked in an upright position. The fuel tank sensors and heating device shall be connected, if necessary. Immediately begin recording the fuel temperature and the air temperature in the enclosure. If a venting/purging fan is still operating, it shall be switched off at this time.

4.3.1.5 The fuel and vapour may be artificially heated to the starting temperatures of 288.7K (15.5 °C) and 294.2K (21.0 °C) ±1K (±1°C) respectively. An initial vapour temperature up to 5<sup>0</sup>C above 21.0<sup>0</sup>C may be used. For this condition, the vapour shall not be heated at the beginning of the diurnal test. When the fuel temperature has been raised to 5.5<sup>0</sup>C below the vapour temperature by following the T<sub>f</sub> function, the remainder of the vapour heating profile shall be followed.

4.3.1.6 As soon as the fuel temperature reaches 14.0 °C:

- 1) Install the fuel filler cap(s);
- 2) Turn off the purge blowers, if not already off at that time;
- 3) Close and seal enclosure doors.



As soon as the fuel reaches a temperature of  $15.5^{\circ}\text{C} \pm 1^{\circ}\text{C}$  the test procedure shall continue as follows:

- a) the hydrocarbon concentration, barometric pressure and the temperature shall be measured to give the initial readings  $C_{\text{HC}, i}$ ,  $p_i$  and  $T_i$  for the tank heat build test;
- b) a linear heat build of  $13^{\circ}\text{C}$  or  $20^{\circ}\text{C} \pm 0.5^{\circ}\text{C}$  over a period of  $60 \pm 2$  minutes shall begin. The temperature of the fuel and fuel vapour during the heating shall conform to the function below to within  $\pm 1.7^{\circ}\text{C}$ , or the closest possible function as described in 3.4.3 of this Chapter:

For exposed type fuel tanks:

Equation1:

$$T_f = 0.3333 * t + 15.5^{\circ}\text{C}$$

$$T_v = 0.3333 * t + 21.0^{\circ}\text{C}$$

For non-exposed type fuel tanks:

Equation2:

$$T_f = 0.2222 * t + 15.5^{\circ}\text{C}$$

$$T_v = 0.2222 * t + 21.0^{\circ}\text{C}$$

where:

$T_f$  = required temperature of fuel ( $^{\circ}\text{C}$ );

$T_v$  = required temperature of vapour ( $^{\circ}\text{C}$ )

$t$  = time from start of the tank heat build in minutes.

- 4.3.1.7 The hydrocarbon analyzer is set to zero and spanned immediately before the end of the test.
- 4.3.1.8 If the heating requirements in clause 4.3.1.6 of this Appendix have been met over the  $60 \pm 2$  minute period of the test, the final hydrocarbon concentration in the enclosure is measured ( $C_{\text{HC},f}$ ). The time or elapsed time of this measurement is recorded, together with the final temperature and barometric pressure  $T_f$  and  $p_f$ .
- 4.3.1.9 The heat source is turned off and the enclosure door unsealed and opened. The heating device and temperature sensor are disconnected from the enclosure apparatus. The vehicle is now removed from the enclosure with the engine switched off.
- 4.3.1.10 To prevent abnormal loading of the carbon canister, fuel tank caps may be removed from the vehicle during the period between the end of the diurnal test phase and the start of the driving cycle. The driving cycle shall begin within 60 minutes of the completion of the breathing loss test.

#### 4.3.2 Driving cycle

4.3.2.1 Following the tank breathing losses test, the vehicle is pushed or otherwise maneuvered on to the chassis dynamometer with the engine switched off. It is then driven through the driving cycle specified for the class of vehicle tested.

#### 4.3.3 Hot soak evaporative emissions test

The level of evaporative emissions is determined by the measurement of hydrocarbon emissions over a 60-minute hot soak period. The hot soak test shall begin within seven minutes of the completion of the driving cycle specified in clause 4.2 of this Appendix and within two minutes of engine shutdown.

4.3.3.1 Before the completion of the test run, the measuring chamber shall be purged for several minutes until a stable hydrocarbon background is obtained. The enclosure mixing fan(s) shall also be turned on at this time.

4.3.3.2 The hydrocarbon analyzer shall be set to zero and spanned immediately prior to the test.

4.3.3.3 The vehicle shall be pushed or otherwise moved into the measuring chamber with the engine switched off.

4.3.3.4 The enclosure doors are closed and sealed gas-tight within seven minutes of the end of the driving cycle.

4.3.3.5 A  $60 \pm 0.5$  minute hot soak period begins when the chamber is sealed. The hydrocarbon concentration, temperature and barometric pressure are measured to give the initial readings  $C_{HC, i}$ ,  $p_i$  and  $T_i$  for the hot soak test. These figures are used in the evaporative emission calculation laid down in clause 5 of this Appendix.

4.3.3.6 The hydrocarbon analyzer shall be zeroed and spanned immediately before the end of the  $60 \pm 0.5$  minute test period.

4.3.3.7 At the end of the  $60 \pm 0.5$  minute test period, measure the hydrocarbon concentration in the chamber. The temperature and the barometric pressure are also measured. These are the final readings  $C_{HC, f}$ ,  $p_f$  and  $T_f$  for the hot soak test used for the calculation in clause 5 of this Appendix. This completes the evaporative emission test procedure.

#### 4.4 Alternative test procedures

4.4.1 At the request of the manufacturer to the satisfaction of the test agency, alternative methods may be used to demonstrate compliance with the requirements of this Appendix. In such cases, the manufacturer shall satisfy the test agency that the results from the alternative test can be correlated with those resulting from the procedure described in this Appendix. This correlation shall be documented and added to the information folder.

### 5.0 CALCULATION OF RESULTS

- 5.1 The evaporative emission tests described in clause 4 of this Appendix allow the hydrocarbon emissions from the tank breathing and hot soak phases to be calculated. Evaporative losses from each of these phases is calculated using the initial and final hydrocarbon concentrations, temperatures and pressures in the enclosure, together with the net enclosure volume.

The formula below is used:

Equation 3:

$$m_{HC} = k \times V \times 10^{-4} \times \left( \frac{C_{HCf} \times p_f}{T_f} - \frac{C_{HCi} \times p_i}{T_i} \right)$$

where:

$m_{HC}$  = mass of hydrocarbon emitted over the test phase (grams);

$C_{HC}$  = hydrocarbon concentration measured in the enclosure (ppm (volume) C<sub>1</sub> equivalent);

$V$  = net enclosure volume in cubic metres corrected for the volume of the vehicle. If the volume of the vehicle is not determined, a volume of 0.14 m<sup>3</sup> shall be subtracted;

$T$  = ambient chamber temperature, K;

$p$  = barometric pressure in kPa;

H/C = hydrogen to carbon ratio;

$k = 1.2 (12 + H/C)$ ;

where:

$i$  is the initial reading;

$f$  is the final reading;

H/C is taken to be 2.33 for tank breathing losses;

H/C is taken to be 2.20 for hot soak losses.);

## 5.2 Overall results of test

The overall evaporative hydrocarbon mass emission for the vehicle is taken to be:

Equation 4:

$$m_{total} = m_{TH} + m_{HS}$$

where:

$m_{total}$  = overall evaporative mass emissions of the vehicle (grams);

$m_{TH}$  = evaporative hydrocarbon mass emission for the tank heat build (grams);

$m_{HS}$  = evaporative hydrocarbon mass emission for the hot soak (grams).

## 6.0 TEST LIMIT VALUES

When tested according to this Appendix, overall evaporative total hydrocarbon mass emission for the vehicle ( $m_{total}$ ) shall not exceed the limit values as specified in the notification.

## APPENDIX 1.1 TO CHAPTER 4

PRECONDITIONING REQUIREMENTS FOR A HYBRID APPLICATION  
BEFORE START OF THE SHED TEST**1.0 SCOPE**

- 1.1 The following preconditioning requirements before starting the SHED test shall apply only to L2-category vehicles equipped with hybrid propulsion.

**2.0 TEST METHODS**

- 2.1 Before starting the SHED test procedure, the test vehicles shall be preconditioned as follows:

**2.1.1 OVC vehicles.**

- 2.1.1.1 As regards OVC vehicles without an operating mode switch, the procedure shall start with the discharge of the electrical energy device/REESS of the vehicle while driving (on the test track, on a chassis dynamometer, etc.) in any of the following conditions:

- (a) at a steady speed of 50 km/h until the fuel-consuming engine of the HEV starts up;
- (b) if a vehicle cannot reach a steady speed of 50 km/h without the fuel-consuming engine starting up, the speed shall be reduced until it can run at a lower steady speed at which the fuel-consuming engine does not start up for a defined time or distance (to be determined by the test agency and the manufacturer);
- (c) in accordance with the manufacturer's recommendation.

The fuel-consuming engine shall be stopped within ten seconds of being automatically started.

- 2.1.1.2 As regards OVC vehicles with an operating mode switch, the procedure shall start with the discharge of the electrical energy device/REESS of the vehicle while driving with the switch in pure electric position (on the test track, on a chassis dynamometer, etc.) at a steady speed of 70 percent  $\pm$  5 percent from the maximum thirty minutes speed of the vehicle. By means of derogation if the manufacturer can prove to the test agency that the vehicle is physically not capable of achieving the thirty minutes speed the maximum fifteen minute speed may be used instead.

Stopping the discharge occurs in the following condition:

- (a) when the vehicle is not able to run at 65 percent of the maximum thirty minutes speed;

(b) when the standard on-board instrumentation gives the driver an indication to stop the vehicle;

(c) after 100 km.

If the vehicle is not equipped with a pure electric mode, the electrical energy device/REESS discharge shall be conducted with the vehicle driving (on the test track, on a chassis dynamometer, etc.) under any of the following conditions:

(a) at a steady speed of 50 km/h until the fuel-consuming engine of the HEV starts up;

(b) if a vehicle cannot reach a steady speed of 50 km/h without the fuel-consuming engine starting up, the speed shall be reduced until it can run at a lower steady speed at which the fuel-consuming engine does not start up for a defined time or distance (to be determined by the test agency and the manufacturer);

(c) in accordance with the manufacturer's recommendation.

The engine shall be stopped within ten seconds of being automatically started. By means of derogation if the manufacturer can prove to the test agency that the vehicle is physically not capable of achieving the thirty minutes speed the maximum fifteen minute speed may be used instead.

2.1.2 **NOVC vehicles.**

2.1.2.1 As regards NOVC vehicles without an operating mode switch, the procedure shall start with a preconditioning of at least two consecutive complete, applicable test type I driving cycles without soak.

2.1.2.2 As regards NOVC vehicles with an operating mode switch, the procedure shall start with a preconditioning of at least two consecutive complete, applicable driving cycles without soak, with the vehicle running in hybrid mode. If several hybrid modes are available, the test shall be carried out in the mode which is automatically set after the ignition key is turned (normal mode). On the basis of information provided by the manufacturer, the test agency shall ensure that the limit values are complied with in all hybrid modes.

2.1.3 **The preconditioning drive shall be carried out according to the type I test cycle in Appendix 6 to chapter 2:**

2.1.3.1 for OVC vehicles this shall be carried out under the same conditions as specified by Condition B of the type I test in Appendix 12 to chapter 2.

2.1.3.2 for NOVC vehicles this shall be carried out under the same conditions as in the type I test.

APPENDIX 2 TO CHAPTER 4

AGEING TEST PROCEDURES FOR EVAPORATIVE EMISSION CONTROL DEVICES

1.0 TEST METHODS FOR AGEING OF EVAPORATIVE EMISSION CONTROL DEVICES

The SHED test shall be conducted with aged evaporative emission control devices fitted. The ageing tests for those devices shall be conducted according to the procedures in this Appendix.

2.0 CARBON CANISTER AGEING

A carbon canister representative of the propulsion family as set out in Chapter 7 shall be selected as test canister. Canister aging shall be conducted at the choice of manufacturer by the carbon canister aging procedure A or B.

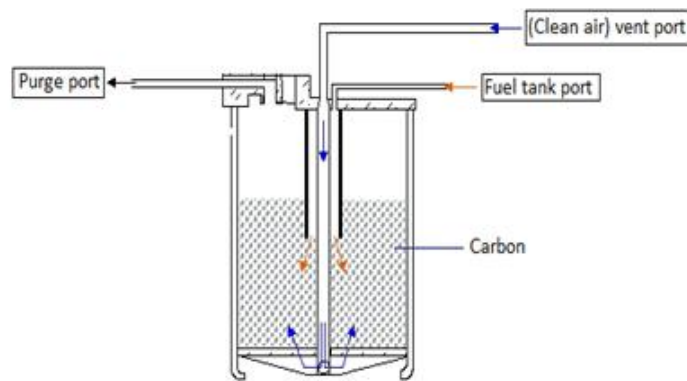

Figure 1: Carbon canister gas flow diagram and ports

2.1 Canister ageing test procedure A

In the case of a multiple carbon canister system, each carbon canister shall undergo the procedure separately. The number of test cycles of carbon canister loading and discharging shall correspond to the number set out in Table 1 of this Appendix or Chapter.

Table 1

Vehicle classification and the required number of loading and discharging of the carbon canister for rapid ageing.

Vehicle classification	Number of cycles
$v_{max} \leq 50 \text{ km/h}$	90
$50\text{km/h} < v_{max} < 130 \text{ km/h}$	170
$v_{max} \geq 130 \text{ km/h}$	300

The dwell time and subsequent purging of fuel vapour shall be run to age the test carbon canister at an ambient temperature of  $24 \text{ }^{\circ}\text{C} \pm 2 \text{ }^{\circ}\text{C}$  as follows:

- 2.1.1 Canister loading part of the test cycle
  - 2.1.1.1 Loading of the carbon canister shall start within one minute of completing the purge portion of the test cycle.
  - 2.1.1.2 The (clean air) vent port of the carbon canister shall be open and the purge port shall be capped. A mix by volume of 50 percent air and 50 percent commercially available petrol or reference fuel shall enter through the tank port of the test carbon canister at a flow rate of 40 grams/hour. The petrol vapour shall be generated at a petrol temperature of  $40 \pm 2$  °C .
  - 2.1.1.3 The test carbon canister shall be loaded each time to 2000 mg or more breakthrough detected by:
    - 2.1.1.3.1 FID analyzer reading (using a mini-SHED or similar) or 5000 ppm instantaneous reading on the FID occurring at the (clean air) vent port; or
    - 2.1.1.3.2 Gravimetric test method using the difference in mass of the test carbon canister charged to 2000 mg or more break through and the purged carbon canister. In this case the test equipment shall be capable of measuring the mass with a minimum accuracy in the range between 0 and +100 mg.
- 2.1.2 Dwell time
 

A five minute dwell period between carbon canister loading and purging as part of the test cycle shall be applied.
- 2.1.3 Canister purging part of the test cycle
  - 2.1.3.1 The test carbon canister shall be purged through the purge port and the tank port shall be capped.
  - 2.1.3.2 Four hundred carbon canister bed volumes shall be purged at a rate of 24 l/min into the vent port.
- 2.2 **Canister ageing test procedure B**
  - 2.2.1 A test cycle will include loading the HC storing components with gasoline vapours up to 80 percent by weight of its maximum storing capacity followed by 10 minutes waiting with the system intake port sealed. Then purge shall start using a flow rate of  $28.3 \pm 5.5$  l/min at  $20 \pm 5$  °C for 7.5 minutes
  - 2.2.2 The method to be used to load the storing components consists of heating a container filled with a pre-measured quantity of petrol up to 80 °C. At 80 °C approximately one third of the petrol will evaporate. The evaporated petrol shall be equivalent to 80 percent (by weight) of the HC storing capacity of the HC storing components. The petrol vapours are allowed to enter through the intake of the storing components.
  - 2.2.3 The number of test cycles of carbon canister loading and purging shall correspond to the number set out in Table 1 of Appendix 2A of this Chapter.

**APPENDIX 2.1 TO CHAPTER 4**  
**ALTERNATE AGEING TEST PROCEDURES FOR EVAPORATIVE**  
**EMISSION CONTROL DEVICES**

- 1.0** Alternate canister ageing procedure may be used. In the case of a multiple canister system each canister must undergo the procedure separately.
- 1.1. The canister is removed from the vehicle. Special care must be taken during this step to avoid damage to components and the integrity of the fuel system.
- 1.2. The weight of the canister must be checked.
- 1.3. The canister is connected to a fuel tank, possibly an external one, filled with reference fuel, to 40% volume of the fuel tank(s).
- 1.4. The fuel temperature in the fuel tank must be between 283 K (10 °C) and 287 K (14 °C).
- 1.5. The (external) fuel tank is heated from 288 K to 318 K (15 °C to 45 °C) (1 °C increase every 9 minutes).
- 1.6. If the canister reaches breakthrough before the temperature reaches 318 K (45 °C), the heat source must be turned off. Then the canister is weighed. If the canister did not reach breakthrough during the heating to 318 K (45 °C), the procedure from 1.3 of this appendix must be repeated until breakthrough occurs.
- 1.7. Breakthrough may be checked as is described in 2.4 and 2.5 of this Chapter, or with the use of another sampling and analytical arrangement capable of detecting the emission of hydrocarbons from the canister at breakthrough.
- 1.8. The weight of the canister must be checked.
- 1.9. The canister must be purged with  $25 \pm 5$  liters per minute with the emission laboratory air until 300 bed volume exchanges are reached.
- 1.10. The steps of the procedure in 1.4 and 1.9 must be repeated nine times. The test may be terminated prior to that, after not less than three ageing cycles, if the weight of the canister after the last cycles has stabilized.
- 1.11. The evaporative emission canister is reconnected and the vehicle restored to its normal operating condition.
- 2.0** One of the methods specified in 2.4 and 2.5 must be used to precondition the evaporative canister. For vehicles with multiple canisters, each canister must be preconditioned separately



- 2.1. Canister emissions are measured to determine breakthrough. Breakthrough is here defined as the point at which the cumulative quantity of hydrocarbons emitted is equal to 2 grams.
- 2.2. Breakthrough may be verified using the evaporative emission enclosure as described in 2.4 and 2.5 respectively. Alternatively, breakthrough may be determined using an auxiliary evaporative canister connected downstream of the vehicle's canister. The auxiliary canister must be well purged with dry air prior to loading
- 2.3. The measuring chamber must be purged for several minutes immediately before the test until a stable background is obtained. The chamber air mixing fan(s) must be switched on at this time. The hydrocarbon analyzer must be zeroed and spanned immediately before the test.
- 2.4. **Canister loading with repeated heat builds to breakthrough**
  - 2.4.1. The fuel tank(s) of the vehicle(s) is (are) emptied using the fuel tank drain(s). This must be done so as not to abnormally purge or abnormally load the evaporative control devices fitted to the vehicle. Removal of the fuel cap is normally sufficient to achieve this.
  - 2.4.2. The fuel tank(s) is (are) refilled with test fuel at a temperature of between 10°C to 14°C to 40% ± 2 % of the tank's normal volumetric capacity. The fuel cap(s) of the vehicle must be fitted at this point.
  - 2.4.3. Within one hour of being refueled the vehicle must be placed, with the engine shut off, in the evaporative emission enclosure. The fuel tank temperature sensor is connected to the temperature recording system. A heat source must be properly positioned with respect to the fuel tank(s) and connected to the temperature controller. The heat source is specified in 3.4 of this chapter. In the case of vehicles fitted with more than one fuel tank, all the tanks must be heated in the same way as described below. The temperatures of the tanks must be identical to within ± 1.5 °C
  - 2.4.4. The fuel may be artificially heated to the starting diurnal temperature of 293 K (20 °C) ± 1 K.
  - 2.4.5. When the fuel temperature reaches at least 292 K (19 °C), the following steps must be taken immediately; the purge blower must be turned off; enclosure doors closed and sealed; and measurement initiated of the hydrocarbon level in the enclosure.
  - 2.4.6. When the fuel temperature of the fuel tank reaches 293 K (20°C) a linear heat build of (15°C) begins. The fuel must be heated in such a way that the temperature of the fuel during the heating conforms to the function below to within ±1.5°C. The elapsed time of the heat build and temperature rise is recorded.

$$T_r = T_0 + 0.2333 \times t$$

Where:

$T_r$  = required temperature (K);

$T_0$  = initial temperature (K);

$t$  = time from start of the tank heat build in minutes.

- 2.4.7. As soon as breakthrough occurs or when the fuel temperature reaches 35 °C, whichever occurs first, the heat source is turned off, the enclosure doors unsealed and opened, the vehicle fuel tank cap(s) removed. If breakthrough has not occurred by the time the fuel temperature reaches 308 °K (35 °C), the heat source is removed from the vehicle, the vehicle removed from the evaporative emission enclosure and the entire procedure outlined in 2.4 of this appendix repeated until breakthrough occurs.

## APPENDIX 3 TO CHAPTER 4

## CALIBRATION OF EQUIPMENT FOR EVAPORATIVE EMISSION TESTING

**1.0 CALIBRATION FREQUENCY AND METHODS**

- 1.1. All equipment shall be calibrated before its initial use and then as often as necessary, and in any case in the month before approval testing. The calibration methods to be used are described in this Appendix.

**2.0 CALIBRATION OF THE ENCLOSURE****2.1. Initial determination of enclosure internal volume**

- 2.1.1. Before its initial use, the internal volume of the chamber shall be determined as follows. The internal dimensions of the chamber are carefully measured, allowing for any irregularities such as bracing struts. The internal volume of the chamber is determined from these measurements.

- 2.1.2. The net internal volume is determined by subtracting 0.14 m<sup>3</sup> from the internal volume of the chamber. Alternatively, the actual volume of the test vehicle may be subtracted.

- 2.1.3. The chamber shall be checked as in clause 2.3 of this Appendix. If the propane mass does not tally to within  $\pm 2$  percent with the injected mass, corrective action is required.

**2.2. Determination of chamber background emissions**

This operation determines that the chamber contains no materials that emit significant amounts of hydrocarbons. The check shall be carried out when the enclosure is brought into service, after any operations in it which may affect background emissions and at least once per year.

- 2.2.1. Calibrate the analyzer (if required). The hydrocarbon analyzer shall be set to zero and spanned immediately before the test.

- 2.2.2. Purge the enclosure until a stable hydrocarbon reading is obtained. The mixing fan is turned on, if not already on.

- 2.2.3. Seal the chamber and measure the background hydrocarbon concentration, temperature and barometric pressure. These are the initial readings  $C_{HCi}$ ,  $p_i$  and  $T_i$  used in the enclosure background calculation.

- 2.2.4. The enclosure is allowed to stand undisturbed with the mixing fan on for four hours.

- 2.2.5. The hydrocarbon analyzer shall be set to zero and spanned immediately before the end of the test.

- 2.2.6. At the end of this time, use the same analyzer to measure the hydrocarbon concentration in the chamber. The temperature and the barometric pressure are also measured. These are the final readings  $C_{HCF}$ ,  $p_f$  and  $T_f$ .
- 2.2.7. Calculate the change in mass of hydrocarbons in the enclosure over the time of the test in accordance with the equation in clause 2.4 of this Appendix. The background emission of the enclosure shall not exceed 400 mg.

**2.3. Calibration and hydrocarbon retention test of the chamber**

The calibration and hydrocarbon retention test in the chamber provides a check on the calculated volume in clause 2.1.1 of this Appendix and also measures any leak rate.

- 2.3.1. Purge the enclosure until a stable hydrocarbon concentration is reached. Turn on the mixing fan, if it is not already on. The hydrocarbon analyzer shall be calibrated (if necessary) then set to zero and spanned immediately before the test.
- 2.3.2. Seal the enclosure and measure the background concentration, temperature and barometric pressure. These are the initial readings  $C_{HCI}$ ,  $p_i$  and  $T_i$  used in the enclosure calibration.
- 2.3.3. Inject approximately 4 grams of propane into the enclosure. The mass of propane shall be measured to an accuracy of  $\pm 2$  percent of the measured value.
- 2.3.4. Allow the contents of the chamber to mix for five minutes. The hydrocarbon analyzer shall be set to zero and spanned immediately before the following test. Measure the hydrocarbon concentration, temperature and barometric pressure. These are the final readings  $C_{HCF}$ ,  $p_f$  and  $T_f$  for the calibration of the enclosure.
- 2.3.5. Using the readings taken in accordance with clauses 2.3.2 and 2.3.4 of this Appendix and the formula in clause 2.4 of this Appendix, calculate the mass of propane in the enclosure. This shall be within  $\pm 2$  percent of the mass of propane measured in accordance with clause 2.3.3 of this Appendix.
- 2.3.6. Allow the contents of the chamber to mix for a minimum of four hours. Then measure and record the final hydrocarbon concentration, temperature and barometric pressure. The hydrocarbon analyzer shall be set to zero and spanned immediately before the end of the test.
- 2.3.7. Using the formula in Clause 2.4 of this Appendix, calculate the hydrocarbon mass from the readings taken in clauses 2.3.6 and 2.3.2 of this Appendix. The mass may not differ by more than 4 percent from the hydrocarbon mass calculated in accordance with clause 2.3.5 of this Appendix.

## 2.4. Calculations

The calculation of net hydrocarbon mass change within the enclosure is used to determine the chamber's hydrocarbon background and leak rate. Initial and final readings of hydrocarbon concentration, temperature and barometric pressure are used in the following formula to calculate the mass change:

Equation 1

$$m_{\text{HC}} = k \cdot V \cdot 10^{-4} \cdot \left( \frac{C_{\text{HC}_f} \cdot P_f}{T_f} - \frac{C_{\text{HC}_i} \cdot P_i}{T_i} \right)$$

where:

$m_{\text{HC}}$  = mass of hydrocarbon in grams;

$C_{\text{HC}}$  = hydrocarbon concentration in the enclosure (ppm carbon (NB: ppm carbon = ppm propane x 3));

$V$  = enclosure volume in cubic metres as measured in accordance with clause 2.1.1 of this Appendix;

$T$  = ambient temperature in the enclosure, K;

$p$  = barometric pressure in kPa;

$k$  = 17.6;

where:

$i$  is the initial reading;

$f$  is the final reading.

## 3.0 CHECKING OF FID HYDROCARBON ANALYZER

### 3.1. Detector response optimization

The FID analyzer shall be adjusted as specified by the instrument manufacturer. Propane in air shall be used to optimize the response on the most common operating range.

### 3.2. Calibration of the HC analyzer

The analyzer shall be calibrated using propane in air and purified synthetic air. A calibration curve shall be established as described in clauses 4.1 to 4.5 of this Appendix.

### 3.3. Oxygen interference check and recommended limits

The response factor ( $R_f$ ) for a particular hydrocarbon species is the ratio of the FID  $C_1$  reading to the gas cylinder concentration, expressed as ppm  $C_1$ .

The concentration of the test gas shall be such as to give a response of approximately 80 percent of full scale deflection, for the operating range. The concentration shall be known to an accuracy of  $\pm 2$  percent in reference to a gravimetric standard expressed in volume. In addition, the gas cylinder shall be preconditioned for 24 hours at between 20°C and 30°C.

Response factors shall be determined when introducing an analyzer into service and thereafter at major service intervals. The reference gas to be used is propane balanced with purified air which shall be taken to give a response factor of 1.00.

The test gas to be used for oxygen interference and the recommended response factor range are given below:

Propane and nitrogen  $0.95 \leq R_f \leq 1.05$ .

#### **4.0 CALIBRATION OF THE HYDROCARBON ANALYZER**

Each of the normally used operating ranges are calibrated by the following procedure:

- 4.1. Establish the calibration curve by at least five calibration points spaced as evenly as possible over the operating range. The nominal concentration of the calibration gas with the highest concentrations shall be at least 80 percent of the full scale.
- 4.2. Calculate the calibration curve by the method of least squares. If the resulting polynomial degree is greater than 3, then the number of calibration points shall be at least the number of the polynomial degree plus 2.
- 4.3. The calibration curve shall not differ by more than 2 percent from the nominal value of each calibration gas.
- 4.4. Using the coefficients of the polynomial derived from clause 4.2 of this Appendix, a table of indicated reading against true concentration shall be drawn up in steps of no greater than 1 percent of full scale. This is to be carried out for each analyser range calibrated. The table shall also contain:
  - a. date of calibration;
  - b. span and zero potentiometer readings (where applicable), nominal scale;
  - c. reference data of each calibration gas used;
  - d. the actual and indicated value of each calibration gas used together with the percentage differences.
- 4.5. Alternative technology (e.g. computer, electronically controlled range switch) may be used if it can be shown to the satisfaction of the test agency that it can ensure equivalent accuracy.

## APPENDIX 4 TO CHAPTER 4

CONFORMITY OF PRODUCTION FOR VEHICLES WITH  
EVaporative EMISSION CONTROL SYSTEM

## 1.0 CONFORMITY OF PRODUCTION (COP)

1.1. For routine end of production-line testing, the holder of the approval may demonstrate compliance by sampling vehicles which shall meet the following requirements. Alternatively, the full test procedure described in this Chapter shall be carried out. At the request of the manufacturer, an alternative test procedure may be used, if the procedure has been presented to and has been accepted during the type approval procedure by the test agency.

1.2. **Test for leakage:**

1.2.1. Vents to the atmosphere from the evaporative emission control system shall be isolated.

1.2.2. A pressure of  $370 \pm 10$  mm of H<sub>2</sub>O shall be applied to the fuel system.

1.2.3. The pressure must be allowed to stabilize prior to isolating the fuel system from the pressure source.

1.2.4. Following isolation of the fuel system, the pressure shall not drop by more than 50 mm of H<sub>2</sub>O in five minutes.

1.3. **Tests for Venting:**

1.3.1 Vents to the atmosphere from the emission control shall be isolated.

1.3.2 A pressure of  $370 \pm 10$  mm of H<sub>2</sub>O shall be applied to the fuel system.

1.3.3 The pressure shall be allowed to stabilize prior to isolating the fuel system from the present source.

1.3.4 The venting outlets from the emission control systems to the atmosphere shall be reinstated to the production condition.

1.3.5 The pressure of the fuel system shall drop to below 100 mm of H<sub>2</sub>O within two minutes

1.4 **Purge Test:**

1.4.1 Equipment capable of detecting an airflow rate of 0.25 litres in one minutes shall be attached to the purge inlet and a pressure vessel of sufficient size to have negligible effect on the purge system shall be connected via a switching valve to the purge inlet, or alternatively.

1.4.2 the manufacturer may use a flow meter of his own choice, after mutual consent from test agency

1.4.3 The vehicle shall be operated in such a manner that any design features of the purge system that could restrict purge operation is detected and the circumstances noted.

- 1.4.4 Whilst the engine is operating within the bounds noted in 1.4.3, the air flow shall be determined by either.
  - 1.4.4.1 The device being switched in a pressure drop from atmosphere to a level indicating that a volume of 0.25 litres of air has flowed into the evaporative emission control system within one minute; or
  - 1.4.4.2 An alternative flow measuring device with a detectable reading of no less than 0.25 litre per minute.
- 1.5 If the requirements of 1.2, 1.3 and 1.4 are not met or non-availability of canister or cannot be verified, the SHED test as per Appendix 1 of this Chapter shall be carried out to establish compliance to COP.

In case of COP test failure, manufacturer shall ensure that all necessary steps are taken to re-establish conformity of production as rapidly as possible by conducting a test(s) as per Appendix 1 of this Chapter and inform to test agency.



**CHAPTER 5****TYPE V TESTS: DURABILITY OF POLLUTION CONTROL DEVICES****0.0 INTRODUCTION**

- 0.1 This Chapter describes the procedures for type V testing to verify the durability of pollution-control devices of L2-category vehicles in accordance with the notification.
- 0.2 The type V test procedure includes mileage accumulation procedures to age the test vehicles in a defined and repeatable way. It also includes the frequency of applied type I emission verification test procedures conducted before, during and after the mileage accumulation of the test vehicles.

**1.0 GENERAL REQUIREMENTS**

- 1.1 The powertrain of test vehicles and pollution-control device type fitted on the test vehicles shall be documented and listed by the manufacturer. The list shall include at a minimum such items as the specifications of the propulsion type and its powertrain, where applicable, the exhaust oxygen sensor(s), catalytic converter(s) type, particulate filter(s) or other pollution-control devices, intake and exhaust systems and any peripheral device(s) that may have an impact on the environmental performance of the approved vehicle. This documentation shall be added to the test report.
- 1.2 After environmental performance type approval, the manufacturer shall provide evidence of the possible impacts on type V test results of any modification, to the emission reduction system specification, the pollution-control device type specifications or other peripheral device(s) interacting with the pollution-control devices, in production of the vehicle type. The manufacturer shall provide the test agency with this documentation and evidence upon request in order to prove that the durability performance of the vehicle type with regard to environmental performance will not be negatively affected by any change in vehicle production, retrospective changes in the vehicle specification, changes in the specifications of any pollution-control device type, or changes in peripheral devices fitted on the approved vehicle type.
- 1.3 Vehicles with side-car shall be exempted from type V durability testing if the manufacturer can provide the evidence and documentation referred to in this Chapter for the vehicle without side car on which the assembly of the vehicle with side-car was based. In all other cases, the requirements of this Chapter shall apply to vehicle with side-car.

**2.0 SPECIFIC REQUIREMENTS**

- 2.1 Test vehicle requirements

- 2.1.1 The test vehicles used for type V durability testing and in particular the pollution-control and peripheral devices, that are relevant for the emission reduction system, shall be representative of the vehicle type produced in series and placed on the market, with regard to environmental performance.
- 2.1.2 The test vehicles shall be in good mechanical condition at the start of mileage accumulation and it shall not have run more than 100 km after it was first started at the end of the production line. The propulsion and pollution-control devices shall not have been used since its manufacture, with the exception of quality control tests and running of the first 100 km.
- 2.1.3 Regardless of the durability test procedure selected by the manufacturer, all pollution-control devices and systems, both including hardware, powertrain software and powertrain calibration, fitted on the test vehicles shall be installed and operating for the entire mileage accumulation period.
- 2.1.4 The pollution-control devices on the test vehicles shall be permanently marked under surveillance of the test agency before the start of mileage accumulation and be listed together with the vehicle identification number, powertrain software and powertrain calibration sets. The manufacturer shall make that list available at the request of the test agency.
- 2.1.5 Maintenance, adjustments and the use of the controls of the test vehicles shall be as recommended by the manufacturer in the appropriate repair and maintenance information. Same shall be also be included in the user's manual.
- 2.1.6 The durability test shall be conducted with commercially available fuel.
- If the test vehicle is/are equipped with a two-stroke engine, lubricating oil shall be used in the proportion and of the grade recommended by the manufacturer in the user manual. The actual quality and quantity used shall be reported.
- 2.1.7 The cooling system of test vehicle shall enable the vehicle to operate at temperatures similar to those obtained during normal road use conditions (oil, coolant, exhaust system, etc.).
- 2.1.8 If the durability test is completed on a test track or road, the reference mass of the test vehicle shall be at least equal to that used for type I emission tests conducted on a chassis dynamometer.
- 2.1.9 If approved by the test agency and to their satisfaction, the type V test procedure may be carried out using a test vehicle of which the body style, gear box (automatic or manual) and wheel or tyre size differ from those of the vehicle type for which the environmental performance type-approval is sought.

- 2.2 In the type V test procedure, mileage shall be accumulated by driving the test vehicles either on a test track, on the road or on a chassis dynamometer. The test track or test road shall be selected at the discretion of the manufacturer. The mileage accumulated in the type I emission verification tests may be added to the total accumulated mileage.
- 2.2.1 Chassis dynamometer used for mileage accumulation
- 2.2.1.1 Chassis dynamometers used to accumulate test type V durability mileage shall enable the durability mileage accumulation cycle in Appendix 1 or 2, as applicable, to be carried out.
- 2.2.1.2 In particular, the dynamometer shall be equipped with systems simulating the same inertia and resistance to progress as those used in the type I emission laboratory test in Chapter 2. Emission analysis equipment is not required for mileage accumulation. The same inertia and flywheel settings and calibration procedures shall be used for the chassis dynamometer referred to in Chapter 2, used to accumulate mileage with the test vehicles.
- 2.2.1.3 The test vehicles may be moved to a different bench in order to conduct type I emission verification tests.
- 2.3 The type I emission verification tests before, during and after durability mileage accumulation shall be conducted according to the test procedures for emissions after cold start set out in Chapter 2. All type I emission verification test results shall be listed and made available to the test agency upon request. The results of type I emission verification tests at the start and the finish of durability mileage accumulation shall be included in the test report. At least the first and last type I emission verification tests shall be conducted or witnessed by the test agency and reported to them. The test report shall confirm and state whether the test agency conducted or witnessed the type I emission verification testing.
- 2.4 Type V test requirements for an L2-category vehicle equipped with a hybrid propulsion
- 2.4.1 For OVC vehicles:
- The electrical energy device/REESS may be charged twice a day during mileage accumulation.
- For OVC vehicles with an operating mode switch, mileage accumulation shall be driven in the mode which is automatically set after the ignition key is turned (normal mode).
- During the mileage accumulation, a change to another hybrid mode is allowed if necessary in order to continue the mileage accumulation, after agreement of the test agency.
- This hybrid mode change shall be recorded in the test report.
- Pollutant emissions shall be measured under the same conditions as specified by Condition B of the type I test (clauses 3.1.3. and 3.2.3. of this Chapter).

2.4.2 For NOVC vehicles:

For NOVC vehicles with an operating mode switch, mileage accumulation shall be driven in the mode which is automatically set after the ignition key is turned on (normal mode).

Pollutant emissions shall be measured in the same conditions as in the type I test.

2.5 The difference between the actual mileage accumulation at each emission test interval and the planned mileage accumulation shall not exceed 200 km.

2.6 During the emission test (Type-I), if the test is affected by abnormal behavior of the vehicle, test shall be discarded. In any other case, the test result shall be deemed effective.

The results which are discarded and the reasons thereof shall be recorded in the test report.

2.7 If multiplicative D.F. is less than 1, it shall be deemed as 1.

If the additive DF is negative, it should be deemed as 0.

2.8 D.F. for each applicable pollutant shall be calculated separately.

**3.0 TEST TYPE V, DURABILITY TEST PROCEDURE SPECIFICATIONS**

The durability test may be carried out at the choice of manufacturer in the following ways prescribed in 3.1, 3.2 & 3.4:

**3.1 Actual durability testing with full mileage accumulation:**

In the durability test procedure with full mileage accumulation to age the test vehicles, the test vehicles shall physically accumulate the full distance set out in the notification and shall be tested in accordance with the defined procedure. The emission test results up to and including the full distance set out in the notification shall be lower than the tailpipe emission limits set out in the notification. Full mileage accumulation shall mean full completion of the assigned test distance laid down in the notification by repeating the driving cycle laid down in Appendix 1 or in Appendix 2.

3.1.1 The emission limits in the applicable type I emission laboratory test cycle, as set out in the notification, of the aged test vehicles shall not exceed when starting mileage accumulation, during the accumulation phase and after full mileage accumulation has been finalized.

3.1.2 Multiple type I emission tests shall be conducted during the full mileage accumulation phase with a frequency and amount of type I test procedures at the choice of the manufacturer and to the satisfaction of the test agency. The type I emission test results shall provide sufficient

statistical relevance to identify the deterioration trend, which shall be representative of the vehicle type with regard to environmental performance as placed on the market (see Figure 1 of this Chapter).

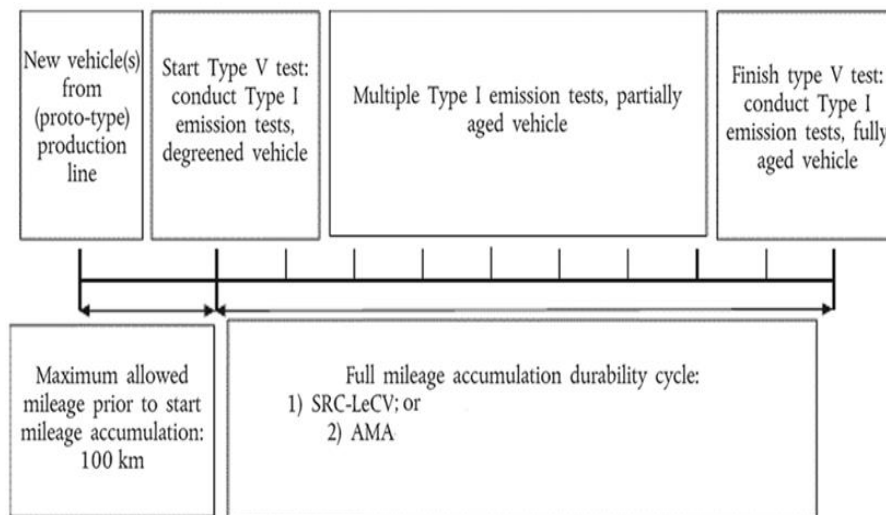

**Figure 1**  
**Test type V – durability test procedure with full mileage accumulation**

### 3.2 Actual durability testing with partial mileage accumulation:

In the durability test procedure for L2-category vehicles with partial mileage accumulation, the test vehicles shall physically accumulate a minimum of 50 % of the full-distance set out in the notification and shall be tested in accordance with the defined procedure. The test results shall be extrapolated up to the full distance set out in the notification. Both the test results and the extrapolated results shall be lower than the tailpipe emission limits set out in the notification. Partial mileage accumulation shall involve completion of a minimum of 50 % of the test distance specified in the notification and compliance with the stop criteria in clause 3.2.3 of this Chapter.

- 3.2.1 The emission limits in the applicable type I emission laboratory test cycle, as set out in the notification, of the tested aged vehicles shall not exceed at the start of mileage accumulation, during the accumulation phase and after the partial accumulation.
- 3.2.2 Multiple type I emission tests shall be conducted during the partial mileage accumulation phase, with the frequency and number of type I test procedures chosen by the manufacturer. The type I emission test results shall provide sufficient statistical relevance to identify the deterioration trend, which shall be representative of the vehicle type with regard to the environmental performance placed on the market (see Figure 2-of this Chapter)

**Test type V–durability test procedure with full mileage accumulation.**

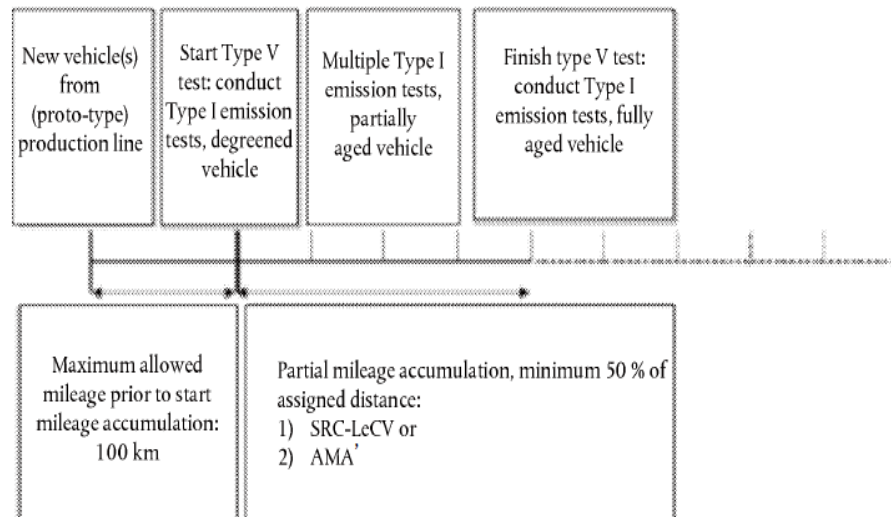

**Figure 2**  
**Test type V – accelerated durability test procedure with partial mileage accumulation**

3.2.3 Stop criteria for the durability test procedure with partial mileage accumulation

Partial mileage accumulation may stop if the following criteria are met:

3.2.3.1 if a minimum of 50 % of the applicable test distance laid down in the notification has been accumulated; and

3.2.3.2 if all the type I emission verification test results are below the emission limits laid down in the notification at all times during the partial mileage accumulation phase; or

3.2.3.3 if the manufacturer cannot prove that the stop criteria in clauses 3.2.3.1 and 3.2.3.2 of this Chapter are met, the mileage accumulation shall continue to the clause where those criteria are met or to the fully accumulated mileage

3.2.4 Data processing and reporting for the durability test procedure with partial mileage accumulation

3.2.4.1 The manufacturer shall use the arithmetic mean of the type I emission test results at each test interval, with a minimum of two emission tests per test interval. All arithmetic means of type I emissions test results shall be plotted per THC, CO, NO<sub>x</sub>, and if applicable NMHC and PM, emission constituent, against accumulation distance rounded to the nearest kilometer.

- 3.2.4.2 The best fit linear line (trend line:  $y = ax + b$ ) shall be fitted and drawn through all these data points based on the method of least squares. This best-fit straight trend line shall be extrapolated over the full durability mileage laid down in the notification. At the request of the manufacturer, the trend line may start as of 20 % of the durability mileage laid down in the notification, in order to take into account possible run-in effects of the pollution-control devices.
- 3.2.4.3 A minimum of four calculated arithmetic mean data points shall be used to draw each trend line, with the first at, or before, 20 % of the durability mileage laid down in the notification and the last one at the end of mileage accumulation; at least two other data points shall be equally spaced between the first and final type I test measurement distances.
- 3.2.4.3.1 If the planned emission (Type I) test is coinciding with a scheduled maintenance kilometer, the manufacturer shall have following options:
- Option-1,
- the emission type I test shall be conducted before or after the maintenance at the choice of manufacturer.
- Option 2:
- the emission type I test shall be conducted before and after the maintenance. Arithmetic mean of the results before maintenance and after maintenance shall be calculated separately. These two arithmetic mean values shall be used determining the best fit line.
- 3.2.4.4 The applicable emission limits set out in the notification shall be plotted in the graphs per emission constituent laid down in clauses 3.2.4.2 and 3.2.4.3 of this Chapter. The plotted trend line shall not exceed these applicable emission limits at any mileage data point. The graph per HC, CO, NO<sub>x</sub>, NMHC and if applicable PM, emission constituent plotted against accumulation distance shall be added to the test report. The list with all the type I emission test results used to establish the best-fit straight trend line shall be made available to the test agency upon request.

Figure 3 of this Chapter: Theoretical example of the type I results of a pollutant is plotted and the best-fit straight trend line is drawn.

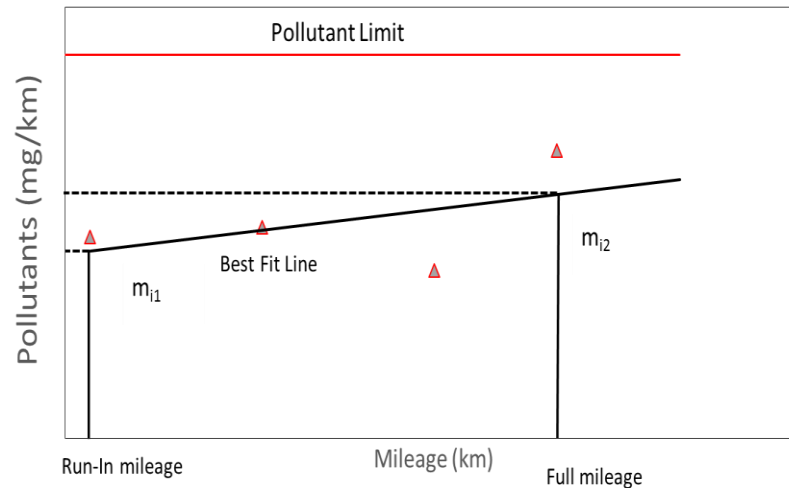

**Fig 3.1 illustrates full mileage accumulation test**

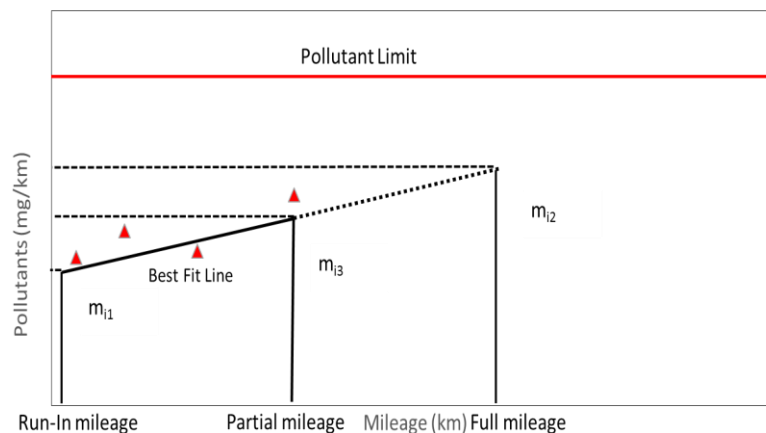

**Fig 3.2 illustrates partial mileage accumulation test.**

3.2.4.5 Trend line parameters a, x and b of the best-fit straight lines and the calculated pollutant value at the end of mileage according to the vehicle category shall be stated in the test report. The graph for all emission constituents shall be plotted in the test report. In the test report it shall also be stated which measurements were taken or witnessed by the test agency and which by the manufacturer.

3.2.4.6 Calculation of Full D.F

The D.F for CO, HC, NMHC, NO<sub>x</sub> and If applicable PM shall be calculated from the best fit line derived from clause 3.2.4.2 of this Chapter. D.F is the ratio of mass emission values for each above pollutants calculated from the best fit line at full mileage and that at 1000 km mileage as given in equation:

$$D.F_{(full)} = \frac{Mi2}{Mi1}$$



At the request of the manufacturer, the additive DF (DF.A.) may be calculated as follows

$$DFA_{(Full)} = Mi_2 - Mi_1$$

Where

$M_{i2}$  = mass emission of the pollutants in g/km at full mileage/ after fully aged golden component.

$M_{i1}$  = mass emission of the pollutants in g/km at 1000 km mileage.

(See Fig 3.1 of this Chapter)

#### 3.2.4.7 D.F Extrapolated

In case the test is done for partial mileage accumulation, the  $M_{i2}$  will be calculated from the extrapolated line at full mileage.

$$D.F_{(extrapolated)} = \frac{Mi_2}{Mi_1}$$

At the request of the manufacturer, the additive DF (DF.A.) may be calculated as follows:

$$DFA_{(extrapolated)} = Mi_2 - Mi_1$$

Where

$M_{i2}$  = mass emission of the pollutants in g/km at extrapolated full mileage.

$M_{i1}$  = mass emission of the pollutants in g/km at 1000 km mileage.

(See Fig 3.2 of this Chapter)

#### 3.2.4.8 D.F Extended

Shall be calculated as per equation:

$$D.F_{(extended)} = \frac{Mi_2}{Mi_3}$$

Where

$M_{i2}$  = mass emission of the pollutants in g/km at full mileage.

$M_{i3}$  = mass emission of the pollutants in g/km at partial mileage or after fitment of partially aged golden component.

(See Fig 3.2 of this Chapter)

### 3.3 **Durability mileage accumulation cycles :**

One of the following two durability mileage accumulation test cycles shall be conducted to age the test vehicles until the assigned test distance laid down in the notification is fully completed according to the full mileage accumulation test procedure set out in clause 3.1 of this Chapter or partially completed according to the partial mileage accumulation test procedure in clause 3.2 of this Chapter.

#### 3.3.1 The Standard Road Cycle (SRC-LeCV) for L2-category vehicles

The Standard Road Cycle (SRC-LeCV) custom tailored for L2-category vehicles is the principle durability type V test cycle composed of a set of four mileage accumulation durability cycles. One of these durability mileage accumulation cycles shall be used to accumulate mileage by the test vehicles according to the technical details laid down in Appendix 1.

#### 3.3.2 The USA EPA Approved Mileage Accumulation cycle

At the choice of the manufacturer, the AMA durability mileage accumulation cycle may be conducted as alternative type V mileage accumulation cycle. The AMA durability mileage accumulation cycle shall be conducted in according with the technical details laid down in Appendix 2.

### 3.4 **Test type V durability verification testing using ‘golden’ pollution-control devices**

#### 3.4.1 The pollution-control devices may be removed from the test vehicles after:

3.4.1.1 full mileage accumulation according to the test procedure in clause 3.1 of this Chapter is completed; or

3.4.1.2 partial mileage accumulation according to the test procedure in clause 3.2 of this Chapter is completed.

3.4.2 At the choice of the manufacturer later on in vehicle development, ‘golden’ pollution-control devices may repeatedly be used for durability performance verification and approval demonstration testing on the same vehicle type with regard to the environmental performance by fitting them on (a) representative parent vehicles representing the propulsion family set out in Chapter 7.

3.4.3 Method of marking, storage conditions, storage location and life of “golden” pollution-control device (no. of tests, no. of years, maximum kms etc) shall be as mutually agreed by the test agency and the manufacturer.

The ‘golden’ pollution-control devices shall be permanently marked with the consent of the test agency and the marking number, the associated type I test results and the specifications shall be made available to the test agency upon request.

3.4.4 In addition, the manufacturer shall mark and store new, non-aged pollution-control devices with the same specifications as those of the ‘golden’ pollution-control devices and, in the event of a request under clause 3.4.5 of this Chapter, make these available also to the test agency, as a reference base.

3.4.5 The test agency shall be given access at any time during or after the environmental performance type-approval process both to the ‘golden’ pollution-control devices and ‘new, non-aged’ pollution- control devices. The test agency may request and witness a verification test by the manufacturer or may have the ‘new, non-aged’ and ‘golden’ pollution-control devices tested by an independent test laboratory in a non-destructive way.

**3.5 Maintenance of vehicle during mileage accumulation:**

3.5.1 A scheduled engine tune up shall be conducted in a manner consistent with owner’s manual / service instructions and specifications provided by the manufacturer for use by customer service personnel. Typical servicing items are listed below:

- a) Contact Breaker points & setting
- b) Ignition timing and setting
- c) Idle speed and Idle air/fuel mixture setting
- d) Tappet clearance
- e) Engine bolt tightening
- f) Spark plugs (Clean, gap setting, replace)
- g) Change of engine and transmission oil, change of elements for oil, air and fuel filters
- h) De-carbonization of engine including silencer in case of two stroke engines.
- i) Adjustment of chains (transmission, valve train)
- j) Adjustment of control cables, clutch etc.
- k) The catalytic converter may be serviced only once during the mileage accumulation, if the failure of the catalytic converter system activates an audible and/ or visual signal which alerts the vehicle operator to the need for catalytic converter system maintenance or if the need for the periodic maintenance of the catalytic converter system is overly signaled to the vehicle operator by appropriate means, e.g., An indicator light or significantly reduced drivability performance.

The catalytic converter may be serviced as recommended by the vehicle manufacturer.

- l) Fuel injectors (Clean)
- m) O2 sensor
- n) EGR
- o) Catalytic Converter
- p) MIL

3.5.2 Other maintenance:

Certain engine components may require maintenance/replacement, which, by its nature cannot be scheduled for periodic interval, but which the manufacturer believes will be necessary, shall be permitted. For example, piston and cylinder replacement caused by piston seizure, excessive wear, which results in the vehicle being inoperative.

3.5.2.1 Any unscheduled engine, emission control system, or fuel system adjustment, repair, removal, disassembly, cleaning or replacement on vehicle shall be performed only in case of significantly reduced driving performance, subject to the following:

- a) part failure or system malfunction or the repairs of such failure or malfunction does not render the vehicle unrepresentative of vehicles in use, and does not require direct access to the combustion chamber except for:
- spark plug, fuel injection component, or
  - removal or replacement of the removable pre-chamber, or
  - decarbonizing

3.5.2.2 Equipment, instruments or tools shall not be used to identify the malfunctioning, mal-adjustment or defective engine components unless the same or equivalent equipment, instrument or tools will be available at the dealerships and other service outlets and are used in conjunction with scheduled maintenance on such components.

3.5.2.3 Emission measurements shall not be used as a means of determining the need for an unscheduled maintenance.

3.5.2.4 Repairs/replacement to vehicle components of test vehicle, other than engine, emission control system or fuel system, shall be performed only as a result of part failure, vehicle system malfunction

3.5.2.5 In case MIL comes on during the mileage accumulation, the fault shall be identified, repaired and reported to the test agency, with relevant documentation data with necessary corrective actions taken.

3.5.3 Records of maintenance activities

All the maintenance work carried out shall be recorded in the test report. The maintenance work reported in the test report shall reflect in the owner's manual/service manual. The manuals shall be provided to the test agency before the start of production.

During the mileage accumulation, a change to another hybrid mode is allowed if necessary in order to continue the mileage accumulation, after agreement of the test agency—and to the satisfaction of the approval authority. This hybrid mode change shall be recorded in the test report.

Pollutant emissions shall be measured under the same conditions as specified by Condition B of the type I test (points 3.1.3. and 3.2.3.).

**4.0 AGEING BENCH EQUIPMENT AND PROCEDURE.**

- 4.1. Ageing bench configuration. The ageing bench shall provide the appropriate exhaust flow rate, temperature, air-fuel ratio; exhaust constituents and secondary air injection at the inlet face of the catalyst.

The standard ageing bench consists of an engine, engine controller, and engine dynamometer. Other configurations may be acceptable (e.g. whole vehicle on a dynamometer, or a burner that provides the correct exhaust conditions), as long as the catalyst inlet conditions and control features specified in this Appendix are met.

A single ageing bench may have the exhaust flow split into several streams providing that each exhaust stream meets the requirements of this appendix. If the bench has more than one exhaust stream, multiple catalyst systems may be aged simultaneously.

- 4.2. Exhaust system installation. The entire catalyst(s)-plus-oxygen sensor(s) system, together with all exhaust piping which connects these components, will be installed on the bench. For engines with multiple exhaust streams, each bank of the exhaust system will be installed separately on the bench in parallel.

For exhaust systems that contain multiple in-line catalysts, the entire catalyst system including all catalysts, all oxygen sensors and the associated exhaust piping will be installed as a unit for ageing. Alternatively, each individual catalyst may be separately aged for the appropriate period of time.

- 4.3. Temperature measurement. Catalyst temperature shall be measured using a thermocouple placed in the catalyst bed at the location where the highest temperature occurs in the hottest catalyst. Alternatively, the feed gas temperature just before the catalyst inlet face may be measured and converted to catalyst bed temperature using a linear transform calculated from correlation data collected on the catalyst design and ageing bench to be used in the ageing process. The catalyst temperature shall be stored digitally at the speed of 1 hertz (one measurement per second)

- 4.4. Air/Fuel measurement. Provisions shall be made for the measurement of the air/fuel (A/F) ratio (such as a wide-range oxygen sensor) as close as possible to the catalyst inlet and outlet flanges. The information from these sensors shall be stored digitally at the speed of 1 hertz (one measurement per second).

- 4.5. Exhaust flow balance. Provisions shall be made to assure that the proper amount of exhaust (measured in grams/second at stoichiometry, with a tolerance of  $\pm 5$  grams/second) flows through each catalyst system that is being aged on the bench.

The proper flow rate is determined based upon the exhaust flow that would occur in the original vehicle's engine at the steady state engine speed and load selected for the bench ageing in clause 3.6. of this Chapter.

- 4.6. Setup. The engine speed, load, and spark timing are selected to achieve a catalyst bed temperature of 800 °C ( $\pm 10$  °C) at steady-state stoichiometric operation.

The air injection system is set to provide the necessary air flow to produce 3,0 % oxygen ( $\pm 0,1$  %) in the steady-state stoichiometric exhaust stream just in front of the first catalyst. A typical reading at the upstream A/F measurement point (required in clause 5 of this Chapter) is lambda 1.16 (which is approximately 3 % oxygen).

With the air injection on, set the 'Rich' A/F ratio to produce a catalyst bed temperature of 890 °C ( $\pm 10$  °C). A typical A/F value for this step is lambda 0,94 (approximately 2 % CO).

- 4.7. Ageing cycle. The standard bench ageing procedures use the standard bench cycle (SBC). The SBC is repeated until the amount of ageing calculated from the bench ageing time (BAT) equation is achieved.

- 4.8. Quality assurance. The temperatures and A/F ratio in clauses 3.3. and 3.4. of this Chapter shall be reviewed periodically (at least every 50 hours) during ageing. Necessary adjustments shall be made to assure that the SBC is being appropriately followed throughout the ageing process

After the ageing has been completed, the catalyst time-at-temperature collected during the ageing process shall be tabulated into a histogram with temperature groups of no larger than 10 °C. The BAT equation and the calculated effective reference temperature for the ageing cycle in accordance with clause 2.4. of Appendix 3 to chapter 7 will be used to determine if the appropriate amount of thermal ageing of the catalyst has in fact occurred. Bench ageing will be extended if the thermal effect of the calculated ageing time is not at least 95 % of the target thermal ageing.

- 4.9 Startup and shutdown. Care should be taken to assure that the maximum catalyst temperature for rapid deterioration (e.g., 1 050 °C) does not occur during startup or shutdown. Special low temperature startup and shutdown procedures may be used to alleviate this concern.

## **5.0 EXPERIMENTALLY DETERMINING THE R-FACTOR FOR BENCH AGEING DURABILITY PROCEDURES**

- 5.1. The R-factor is the catalyst thermal reactivity coefficient used in the bench ageing time (BAT) equation. Manufacturers may determine the value of R experimentally using the following procedures.

- 5.2 Using the applicable bench cycle and ageing bench hardware, age several catalysts (minimum of 3 of the same catalyst design) at different control temperatures between the normal operating temperature and the damage limit temperature. Measure emissions (or catalyst inefficiency (1-catalyst efficiency)) for each exhaust constituent. Assure that the final testing yields data between one- and two-times the emission standard

- 5.3. Estimate the value of R and calculate the effective reference temperature (Tr) for the bench ageing cycle for each control temperature in accordance with clause 2.4 of Appendix 3 to Chapter 6.

- 5.4. Plot emissions (or catalyst inefficiency) versus ageing time for each catalyst. Calculate the least-squared best-fit line through the data. For the data set to be useful for this purpose the data should have an approximately common intercept between 0 and 6400 km.

- 5.5. Calculate the slope of the best-fit line for each ageing temperature.
- 5.6. Plot the natural log (ln) of the slope of each best-fit line (determined in clause 4.5 of this Chapter) along the vertical axis, versus the inverse of ageing temperature ( $1/(\text{ageing temperature, } ^\circ\text{C})$ ) along the horizontal axis. Calculate the least squared best-fit lines through the data. The slope of the line is the R-factor. See the following graph for an example

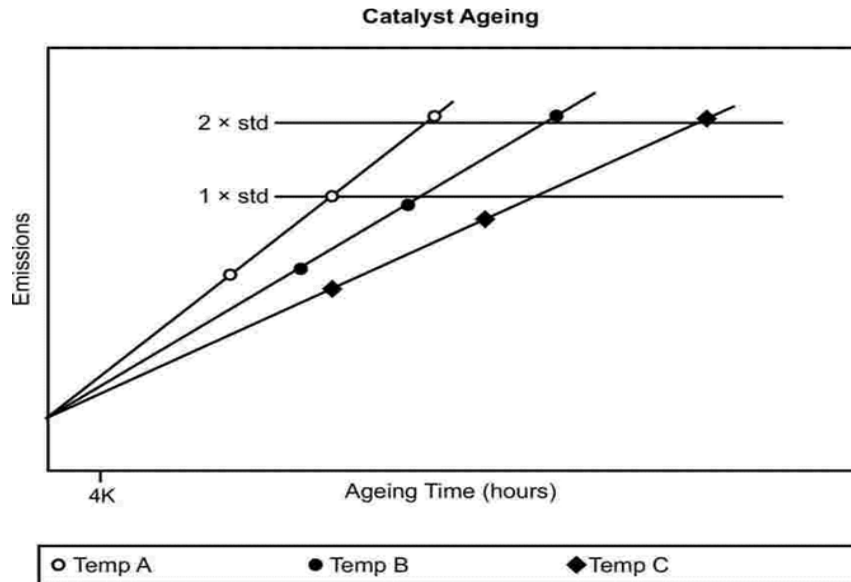

- 5.7. Compare the R-factor to the initial value that was used in accordance with clause 4.3 of this Chapter. If the calculated R-factor differs from the initial value by more than 5 %, choose a new R-factor that is between the initial and calculated values, and then repeat steps of clause 4 of this Chapter, to derive a new R-factor. Repeat this process until the calculated R-factor is within 5 % of the initially assumed R-factor.
- 5.8. Compare the R-factor determined separately for each exhaust constituent. Use the lowest R-factor (worst case) for the BAT equation.

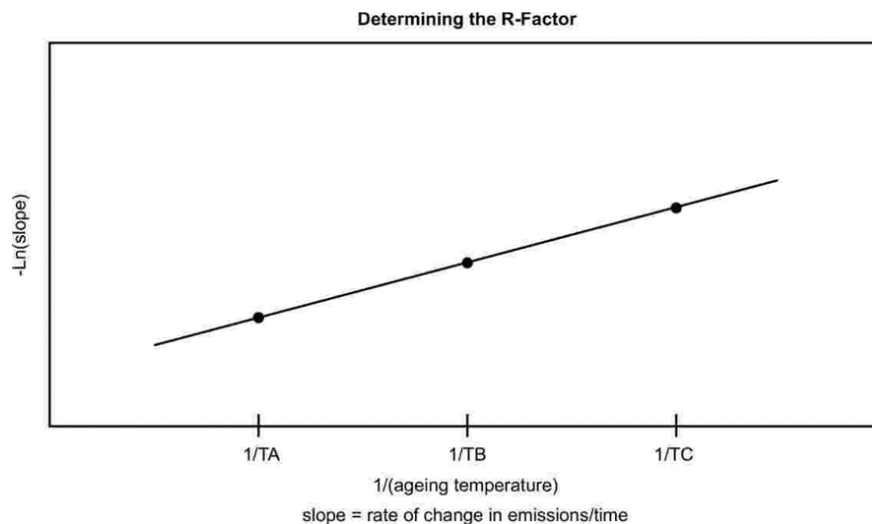

**APPENDIX 1 TO CHAPTER 5**  
**THE STANDARD ROAD CYCLE FOR L2-CATEGORY VEHICLES**  
**(SRC-LECV)**

**1.0 INTRODUCTION**

- 1.1 The Standard Road Cycle for L2-Category Vehicles (SRC-LeCV) is a representative kilometer accumulation cycle to age L2-category vehicles and in particular their pollution-control devices in a defined, repeatable and representative way. The test vehicles may run the SRC-LeCV on the road, on a test track or on a kilometer accumulation chassis dynamometer.
- 1.2 The SRC-LeCV shall consist of five laps of a 6 km course. The length of the lap may be changed to accommodate the length of the kilometer accumulation test track or test road. The SRC-LeCV shall include four different vehicle speed profiles.
- 1.3 The manufacturer may request to be allowed alternatively to perform the next higher numbered test cycle, with the agreement of the test agency, if it considers that this better represents the real-world use of the vehicle.

**2.0 SRC-LECV TEST REQUIREMENTS**

- 2.1 If the SRC-LeCV is performed on a kilometer accumulation chassis dynamometer:
- 2.1.1 The chassis dynamometer shall be equipped with systems equivalent to those used in the type I emission laboratory test set out in Chapter 2, simulating the same inertia and resistance to progress. Emission analysis equipment shall not be required for mileage accumulation. The same inertia and flywheel settings and calibration procedures shall be used for the chassis dynamometer used to accumulate mileage with the test vehicles set out in Chapter 2;
- 2.1.2 The test vehicles may be moved to a different chassis dynamometer in order to conduct Type I emission verification tests. This dynamometer shall enable the SRC-LeCV to be carried out;
- 2.1.3 the chassis dynamometer shall be configured to give an indication after each quarter of the 6 km course has been passed that the test rider or robot rider shall proceed with the next set of actions;
- 2.1.4 a timer displaying seconds shall be made available for execution of the idling periods;
- 2.1.5 the distance travelled shall be calculated from the number of rotations of the roller and the roller circumference.



- 2.2 If the SRC-LeCV is not performed on a kilometer accumulation chassis dynamometer:
- 2.2.1 the test track or test road shall be selected at the discretion of the manufacturer to the satisfaction of the test agency;
- 2.2.2 the track or road selected shall be shaped so as not to significantly hinder the proper execution of the test instructions;
- 2.2.3 the route used shall form a loop to allow continuous execution;
- 2.2.4 track lengths which are multiples, half or quarter of this length shall be permitted. The length of the lap may be changed to accommodate the length of the mileage accumulation track or road;
- 2.2.5 four points shall be marked, or landmarks identified, on the track or road which equate to quarter intervals of the lap;
- 2.2.6 the distance accumulated shall be calculated from the number of cycles required to complete the test distance. This calculation shall take into account the length of the road or track and chosen lap length. Alternatively, an electronic means of accurately measuring the actual distance travelled may be used. The odometer of the vehicle shall not be used.
- 2.2.7 Examples of test track configurations:

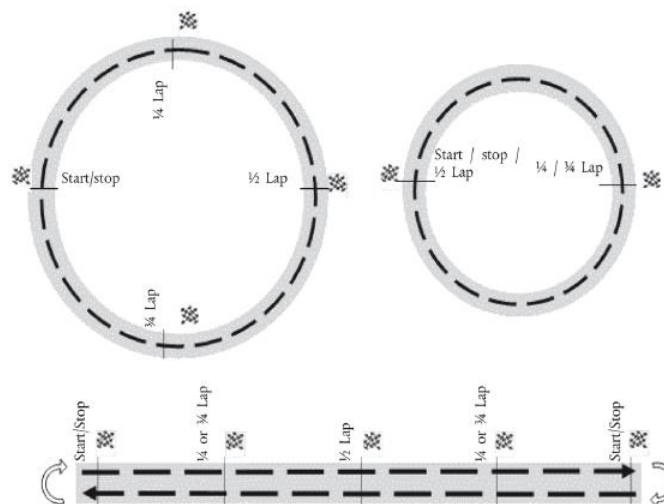

**Figure 1**  
**Simplified graphic of possible test track configurations**

- 2.3 The total distance travelled shall be the applicable durability mileage set out in the notification, plus one complete SRC-LeCV sub-cycle (30 km).
- 2.4 No stopping is permitted mid-cycle. Any stops for Type I emission tests, maintenance, soak periods, refueling, etc. shall be performed at the end of one complete SRC-LeCV sub-cycle. If the vehicle travels to the testing area under its own power, only moderate acceleration and deceleration shall be used and the vehicle shall not be operated at full throttle.

2.5 The four cycles shall be selected on the basis of the maximum design vehicle speed of the L2-category vehicle and the engine capacity or, in the case of pure electric or hybrid propulsions, the maximum design speed of the vehicle and the net power.

2.6 **Vehicle classification for the Type V test**

2.6.1 For the purpose of accumulating mileage in the SRC-LeCV, the L2-vehicle categories shall be grouped as follows:

**Table1**  
**L2-vehicle category groups for the SRC-LeCV**

SRC cycle classification	WMTC classification
1	Class 1
2	Class 2-1
2	Class 2-2
3	Class 3-1
4	Class 3-2

2.6.2 The application of the vehicle classification criteria in Table 1 of this Appendix shall be performed by applying the following classification criteria hierarchy:

- 1) Maximum design vehicle speed (km/h);
- 2) Maximum net or continuous rated power (kW).

2.6.3 If,

- a) the acceleration capability of the L2-category vehicle is not sufficient to carry out the acceleration phases within the prescribed distances; or
- b) the prescribed maximum vehicle speed in the individual cycles cannot be achieved owing to a lack of propulsion power; or
- c) the maximum design vehicle speed is restricted to a vehicle speed lower than the prescribed SRC-LeCV vehicle speed,

the vehicle shall be driven with the accelerator device fully open until the vehicle speed prescribed for the test cycle is reached or until the limited maximum design vehicle speed is reached. Subsequently the test cycle shall be carried out as prescribed for the vehicle category. Significant or frequent deviations from the prescribed vehicle speed tolerance band and the associated justification shall be reported to the test agency and be included in the Type V test report.

- 2.7 **SRC-LeCV general driving instructions**
- 2.7.1 Idle instructions
- 2.7.1.1 If not already stopped, the vehicle shall decelerate to a full stop and the gear shifted to neutral. The throttle shall be fully released and ignition shall remain on. If a vehicle is equipped with a stop-start system or, in the case of a hybrid electric vehicle, the combustion engine switches off when the vehicle is stationary; it shall be ensured that the combustion engine continues to idle.
- 2.7.1.2 The vehicle shall not be prepared for the following action in the test cycle until the full required idle duration has passed.
- 2.7.2 Acceleration instructions:
- 2.7.2.1 accelerate to the target vehicle speed using the following sub-action methodologies:
- 2.7.2.1.1 moderate: normal medium part-load acceleration, up to approximately half throttle.
- 2.7.2.1.2 hard: high part-load acceleration up to full throttle.
- 2.7.2.2 if moderate acceleration is no longer able to provide a noticeable increase in actual vehicle speed to reach a target vehicle speed, then hard acceleration shall be used and ultimately full throttle.
- 2.7.3 Deceleration instructions:
- 2.7.3.1 decelerate from either the previous action or from the maximum vehicle speed attained in the previous action, whichever is lower.
- 2.7.3.2 if the next action sets the target vehicle speed at 0 km/h, the vehicle shall be stopped before proceeding.
- 2.7.3.3 moderate deceleration: normal let-off of the throttle; brakes, gears and clutch may be used as required.
- 2.7.3.4 coast-through deceleration: full let-off of the throttle, clutch engaged and in gear, no foot/hand control actuated, no brakes applied. If the target speed is 0 km/h (idle) and if the actual vehicle speed is  $\leq 5$  km/h, the clutch may be disengaged, the gear shifted to neutral and the brakes used in order to prevent engine stall and to entirely stop the vehicle. An upshift is not allowed during a coast-through deceleration. The rider may downshift to increase the braking effect of the engine. During gear changes, extra care shall be afforded to ensure that the gear change is performed promptly, with minimum (i.e.  $< 2$  seconds) coasting in neutral gear, clutch and partial clutch use. The vehicle manufacturer may request to extend this time with the agreement of the test agency if absolutely necessary.

- 2.7.3.5 coast-down deceleration: deceleration shall be initiated by de-clutching (i.e. separating the drive from the wheels) without the use of brakes until the target vehicle speed is reached.
- 2.7.4 Cruise instruction:
  - 2.7.4.1 if the following action is ‘cruise’, the vehicle may be accelerated to attain the target vehicle speed
  - 2.7.4.2 the throttle shall continue to be operated as required to attain and remain at the target cruising vehicle speed.
- 2.7.5 A driving instruction shall be performed in its entirety. Additional idling time, acceleration to above, and deceleration to below, the target vehicle speed is permitted in order to ensure that actions are performed fully.
- 2.7.6 Gear changes shall be carried out according to the guidance laid down in Appendix 8 of Chapter 2. Alternatively, guidance provided by the manufacturer to the consumer may be used if approved by the test agency.
- 2.7.7 Where the test vehicle cannot reach the target vehicle speeds set out in the applicable SRC-LeCV, it shall be operated at wide open throttle and using other available options to attain maximum design speed.
- 2.8 **SRC-LeCV test steps**

The SRC-LeCV test shall consist of the following steps:

  - 2.8.1 the maximum design speed of the vehicle and either the engine capacity or net power, as applicable, shall be obtained;
  - 2.8.2 The required SRC-LeCV shall be selected from Table 1 of this Appendix and the required target vehicle speeds and detailed driving instructions from Table 2 of this Appendix.
  - 2.8.3 A table of target vehicle speeds shall be prepared indicating the nominal target vehicle speeds set out in Tables Ap 2 and Ap 3 of Appendix 1 of this chapter and the attainable target vehicle speeds of the vehicle in a format preferred by the manufacturer to the satisfaction of the test agency.
  - 2.8.4 In accordance with clause 2.2.5-of this Appendix, quarter divisions of the lap length shall be marked or identified on the test track or road, or a system shall be used to indicate the distance being passed on the chassis dynamometer.
  - 2.8.5 After each sub-lap is passed, the required list of actions of Tables 2 and 3 of this Appendix shall be performed in order and in accordance with clause 2.7 of this Appendix regarding the general driving instructions to or at the next target vehicle speed.

2.8.6 The maximum attained vehicle speed may deviate from the maximum design vehicle speed depending on the type of acceleration required and track conditions. Therefore, during the test the actual attained vehicle speeds shall be monitored to see if the target vehicle speeds are being met as required. Special attention shall be paid to peak vehicle speeds and cruise vehicle speeds close to the maximum design vehicle speed and the subsequent vehicle speed differences in the decelerations.

2.8.7 Where a significant deviation is consistently found when performing multiple sub-cycles, the target vehicle speeds shall be adjusted in the table in clause 2.8.4 of this Appendix. The adjustment needs to be made only when starting a sub-cycle and not in real time.

2.9 **SRC-LeCV detailed test cycle description**

2.9.1 Graphical overview of the SRC-LeCV

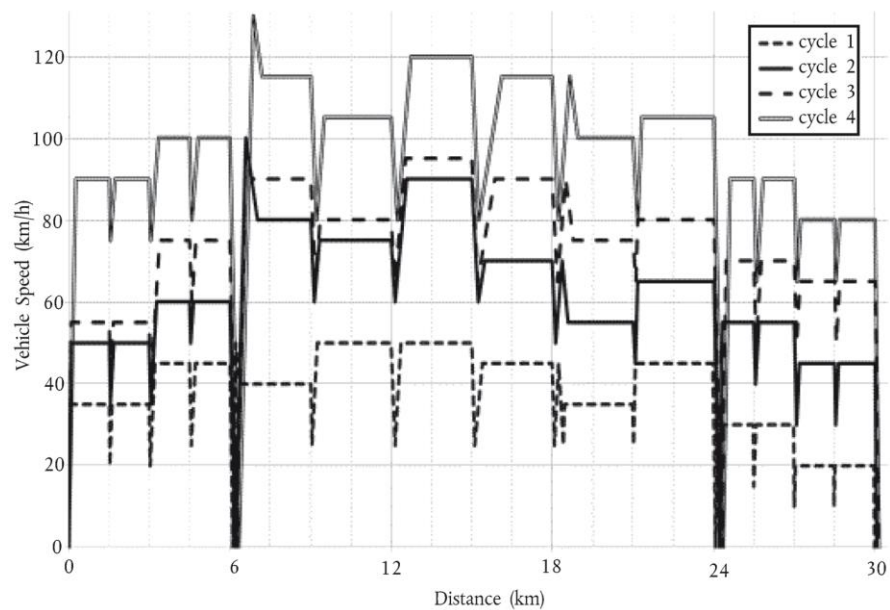

**Figure 2**  
**SRC-LeCV, example distance accumulation characteristics for all four cycles**

**Table 2**  
**Actions and sub-actions for each cycle and sub-cycle,**

Cycle					1		2		3		4		
Lap	Sub-lap	Action	Sub-action	Time (s)	To / at	By	To/at	By	To/at	By	To/at	By	
1	1st 1/4												
		Stop & Idle		10									
		Accelerate	Hard		35		50		55		90		
			Cruise			35		50		55		90	
	2nd 1/4												
		Decelerate	Moderate			15		15		15		15	
		Accelerate	Moderate		35		50		55		90		
			Cruise			35		50		55		90	
	3rd 1/4												
		Decelerate	Moderate			15		15		15		15	
		Accelerate	Moderate		45		60		75		100		
			Cruise			45		60		75		100	
4th 1/4													
	Decelerate	Moderate			20		10		15		20		
	Accelerate	Moderate		45		60		75		100			
		Cruise			45		60		75		100		
2	1st 1/2												
		Decelerate	Coast-through		0		0		0		0		
		Stop & Idle		10									
		Accelerate	Hard		50		100		100		130		
		Decelerate	Coast-down			10		20		10		15	
		Optional acceleration	Hard		40		80		90		115		
		Cruise			40		80		90		115		
2nd 1/2													
	Decelerate	Moderate			15		20		25		35		
	Accelerate	Moderate		50		75		80		105			
		Cruise			50		75		80		105		
3	1st 1/2												
		Decelerate	Moderate			25		15		15		25	
		Accelerate	Moderate		50		90		95		120		
			Cruise			50		90		95		120	
	2nd 1/2												
		Decelerate	Moderate			25		10		30		40	
Accelerate		Moderate		45		70		90		115			
		Cruise			45		70		90		115		
4	1st 1/2												
		Decelerate	Moderate			20		20		25		35	
		Accelerate	Moderate		45		70		90		115		

		Decelerate	Coast-down			20		15		15		15
		Optional acceleration	Moderate		35		55		75		100	
		Cruise			35		55		75		100	
	2nd 1/2											
		Decelerate	Moderate			10		10		10		20
		Accelerate	Moderate		45		65		80		105	
		Cruise			45		65		80		105	
5	1st 1/4											
		Decelerate	Coast-through		0		0		0		0	
		Stop & Idle		45								
		Accelerate	Hard		30		55		70		90	
		Cruise			30		55		70		90	
	2nd 1/4											
		Decelerate	Moderate			15		15		20		25
		Accelerate	Moderate		30		55		70		90	
		Cruise			30		55		70		90	
	3rd 1/4											
		Decelerate	Moderate			20		25		20		25
		Accelerate	Moderate		20		45		65		80	
		Cruise			20		45		65		80	
	4th 1/4											
		Decelerate	Moderate			10		15		15		15
		Accelerate	Moderate		20		45		65		80	
		Cruise			20		45		65		80	
		Decelerate	Coast-through		0		0		0		0	

2.9.3 Soak procedures in the SRC-LeCV

The SRC-LeCV soak procedure shall consist of the following steps:

- 2.9.3.1 a full SRC-LeCV sub-cycle (approximately 30 km) shall be completed;
- 2.9.3.2 a test Type I emission test may be performed if deemed necessary for statistical relevance;
- 2.9.3.3 any required maintenance shall be undertaken and the test vehicle may be refueled;
- 2.9.3.4 the test vehicle shall be set to idle with the combustion engine running for a minimum of one hour with no user input;
- 2.9.3.5 the propulsion of the test vehicle shall be turned off;

- 2.9.3.6 the test vehicle shall be cooled down and soaked under ambient conditions for a minimum of six hours (or four hours with a fan and lubrication oil at ambient temperature);
- 2.9.3.7 the vehicle may be refueled and mileage accumulation shall be resumed as required at lap 1, sub-lap 1 of the SRC-LeCV sub-cycle in Table 2 of this Appendix.
- 2.9.3.8 the SRC-LeCV soak procedure shall not replace the regular soak time for Type I emission tests laid down in Chapter 2. The SRC-LeCV soak procedure may be coordinated so as to be performed after each maintenance interval or after each emission laboratory test.
- 2.9.3.9 Test Type V soak procedure for actual durability testing with full mileage accumulation
  - 2.9.3.9.1 During the full mileage accumulation phase set out in clause 3.1 of Chapter 5, the test vehicles shall undergo a minimum number of soak procedures set out in Table 3 of this Appendix. These procedures shall be evenly distributed over the accumulated mileage.
  - 2.9.3.9.2 The number of soak procedures to be conducted during the full mileage accumulation phase shall be determined according to the following table:

**Table 3  
Number of soak procedures depending on the SRC-LeCV in  
Table 1 of this Appendix.**

SRC-LeCV, cycle No	Minimum number of test Type V soak procedures
1 & 2	3
3	4
4	6

- 2.9.3.10 Test Type V soak procedure for actual durability testing with partial mileage accumulation
 

During the partial mileage accumulation phase set out in clause 3.2 of Chapter 5, the test vehicles shall undergo four soak procedures as set out in clause 2.9.3 of this Appendix. These procedures shall be evenly distributed over the accumulated mileage.



**APPENDIX 2 TO CHAPTER 5**

**THE USA EPA APPROVED MILEAGE ACCUMULATION DURABILITY CYCLE (AMA)**

**1.0 INTRODUCTION**

1.1 The AMA test cycle shall be completed by repeating the AMA sub-cycle in clause 2 of this Appendix until the applicable durability mileage in notification has been accumulated.

1.2 The AMA test cycle shall be composed of 11 sub-sub-cycles covering six kilometers each.

**2.0 AMA TEST CYCLE REQUIREMENTS**

2.1 For the purpose of accumulating mileage in the AMA test durability, the L2-category vehicles shall be grouped as follows:

**Table1**

**Grouping of L2-category vehicles for the purpose of the AMA mileage accumulation test**

<b>L2-category vehicle class</b>	<b>Engine capacity (cm 3 )</b>	<b>V max (km/h)</b>
I	< 150	Not applicable
II	≥ 150	< 130
III	≥ 150	≥ 130

2.2 If the AMA test cycle is performed on a kilometer accumulation chassis dynamometer, the distance travelled shall be calculated from the number of rotations of the roller and the roller circumference.

2.3 One AMA test sub-cycle shall be performed as follows:

2.4.1

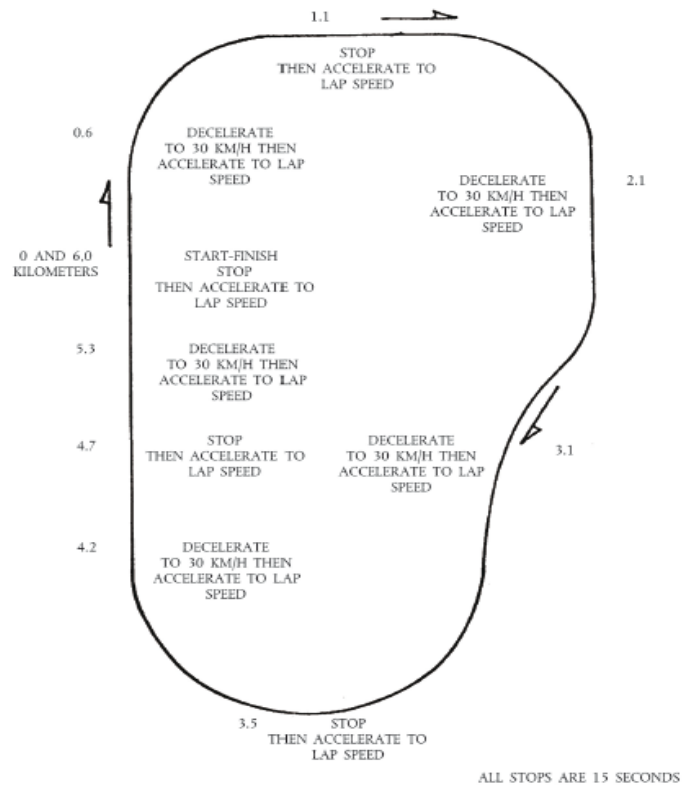

**Figure 1**  
**Driving schedule AMA test sub-sub-cycle**

2.4.2 The AMA test cycle consisting of 11 sub-sub-cycles shall be driven at the following sub-sub-cycle vehicle speeds:

**Table 2**  
**Maximum vehicle speed in one AMA sub-cycle**

Sub-sub cycle No	Class I vehicle (km/h)	Class II vehicle (km/h)	Class III vehicle Option I (km/h)	Class III vehicle Option II (km/h)
1	65	65	65	65
2	45	45	65	45
3	65	65	55	65
4	65	65	45	65
5	55	55	55	55
6	45	45	55	45
7	55	55	70	55
8	70	70	55	70
9	55	55	46	55
10	70	90	90	90
11	70	90	110	110

- 2.4.3 Manufacturers may select one of two cycle vehicle speed options for class III L-category vehicles, completing the entire procedure on their selected option.
- 2.4.4 During the first nine AMA sub-sub-cycles, the test vehicle is stopped four times with the engine idling each time for 15 seconds.
- 2.4.5 The AMA sub-cycle shall consist of five decelerations in each sub-sub-cycle, dropping from cycle speed to 30 km/h. The test vehicle shall then gradually be accelerated again until the cycle speed shown in Table 2 of this Appendix is attained.
- 2.4.6 The 10th sub-sub-cycle shall be carried out at a steady speed according to the L-category vehicle class as referred in Table 1 Table 2 of this Appendix.
- 2.4.7 The 11th sub-sub-cycle shall begin with a maximum acceleration from stop point up to lap speed. At halfway, the brakes are applied normally until the test vehicle comes to a stop. This shall be followed by an idle period of 15 seconds and a second maximum acceleration. This completes one AMA sub-cycle.
- 2.4.8 The schedule shall then be restarted from the beginning of the AMA sub-cycle.
- 2.4.9 At the manufacturer's request, and with the agreement of test agency, an L-category vehicle type may be placed in a higher class provided it is capable of complying with all aspects of the procedure for the higher class.
- 2.4.10 At the manufacturer's request, and with the agreement of the test agency, shall the L-category vehicle be unable to attain the specified cycle speeds for that class, the L-category vehicle type shall be placed in a lower class. If the vehicle is unable to achieve the cycle speeds required for this lower class, it shall attain the highest possible speed during the test and full throttle shall be applied if necessary to attain that vehicle speed.

**APPENDIX 3 TO CHAPTER 5**  
**BENCH AGEING DURABILITY TEST**

**1.0 BENCH AGEING DURABILITY TEST**

1.1 The vehicle tested according the procedure laid down in this appendix has driven more than 100 accumulated kilometers after it was first started at the end of the production line.

1.2 The fuel used during the test shall be the one of the specified fuels in Appendix 2 of Chapter 2.

**2.0 PROCEDURE FOR VEHICLES WITH POSITIVE IGNITION ENGINES**

2.1 The following bench ageing procedure shall be applicable for positive-ignition vehicles including hybrid vehicles which use a catalyst as the principle after-treatment emission control device.

The bench ageing procedure requires the installation of the catalyst-plus-oxygen sensor system on a catalyst ageing bench.

Ageing on the bench shall be conducted by following the standard bench cycle (SBC) for the period of time calculated from the bench ageing time (BAT) equation. The BAT equation requires, as input, catalyst time-at-temperature data measured during the Standard Road Cycle (SRC-LeCV) described in Appendix 1. As an alternative, if applicable, the catalyst time-at-temperature data measured during the AMA durability cycle, as described in Appendix 2, may be used.

2.2 Standard bench cycle (SBC). Standard catalyst bench ageing shall be conducted following the SBC. The SBC shall be run for the period of time calculated from the BAT equation. The SBC is described in Appendix 4.

2.3 Catalyst time-at-temperature data. Catalyst temperature shall be measured during at least two full cycles of the SRC-LeCV cycle as described in Appendix 1, or if applicable at least two full cycles of AMA as described in Appendix 2.

Catalyst temperature shall be measured at the highest temperature location in the hottest catalyst on the test vehicle. Alternatively, the temperature may be measured at another location providing that it is adjusted to represent the temperature measured at the hottest location using good engineering judgment.

Catalyst temperature shall be measured at a minimum rate of one hertz (one measurement per second).

The measured catalyst temperature results shall be tabulated into a histogram with temperature groups of no larger than 25 °C.

2.4 Bench-ageing time. Bench ageing time shall be calculated using the bench ageing time (BAT) equation as follows:

$$t_{e \text{ for a temperature bin}} = t_{th} e^{((R/T_r)-(R/T_v))}$$

Total  $t_e$  = Sum of  $t_e$  over all the temperature groups

bench ageing time = A (Total  $t_e$ )

Where:

A	1.1 This value adjusts the catalyst ageing time to account for deterioration from sources other than thermal ageing of the catalyst.
R	Catalyst thermal reactivity = 18500
$t_{th}$	The time (in hours) measured within the prescribed temperature bin of the vehicle's catalyst temperature histogram adjusted to a full useful life basis e.g., if the histogram represented 400 km, and useful life is, in accordance with Chapter 8 for example for 20000 km; all histogram time entries would be multiplied by 50 (20000/400).
Total $t_e$	The equivalent time (in hours) to age the catalyst at the temperature of $T_r$ on the catalyst ageing bench using the catalyst ageing cycle to produce the same amount of deterioration experienced by the catalyst due to thermal deactivation over the use for live distance specific for the vehicle class in Chapter 8 for example for 20000 km
$t_{e \text{ for a temperature bin}}$	The equivalent time (in hours) to age the catalyst at the temperature of $T_r$ on the catalyst ageing bench using the catalyst ageing cycle to produce the same amount of deterioration experienced by the catalyst due to thermal deactivation at the temperature bin of $T_v$ over the use for live distance specific for the vehicle class for example for 20000 km
$T_r$	The effective reference temperature (in °K) of the catalyst on the catalyst bench run on the bench ageing cycle. The effective temperature is the constant temperature that would result in the same amount of ageing as the various temperatures experienced during the bench ageing cycle.
$T_v$	The mid-point temperature (in °K) of the temperature bin of the vehicle on-road catalyst temperature histogram.

2.5. Effective reference temperature on the standard bench cycle (SBC). The effective reference temperature of the SBC shall be determined for the actual catalyst system design and actual ageing bench which will be used using the following procedures:

- (a) Measure time-at-temperature data in the catalyst system on the catalyst ageing bench following the SBC. Catalyst temperature shall be measured at the highest temperature location of the hottest catalyst in the system. Alternatively, the temperature may be measured at another location providing that it is adjusted to represent the temperature measured at the hottest location

Catalyst temperature shall be measured at a minimum rate of one hertz (one measurement per second) during at least 20 minutes of bench ageing. The measured catalyst temperature results shall be tabulated into a histogram with temperature groups of no larger than 10°C.

- (b) The BAT equation shall be used to calculate the effective reference temperature by iterative changes to the reference temperature (Tr) until the calculated ageing time equals or exceeds the actual time represented in the catalyst temperature histogram. The resulting temperature is the effective reference temperature on the SBC for that catalyst system and ageing bench

2.6. Catalyst ageing bench. The catalyst ageing bench shall follow the SBC and deliver the appropriate exhaust flow and emission level in line with the exhaust flow of engine for which the catalyst is designed, exhaust constituents, and exhaust temperature at the face of the catalyst.

All bench ageing equipment and procedures shall record appropriate information (such as measured A/F ratios and time-at-temperature in the catalyst) to assure that sufficient ageing has actually occurred.

2.7. Required testing. For calculating deterioration factors at least two Type 1 tests before bench ageing of the emission control hardware and at least two Type 1 tests after the bench-aged emission hardware is reinstalled have to be performed on the test vehicle

Calculation of the deterioration factors has to be done in accordance with the calculation method as specified below.

A multiplicative exhaust emission deterioration factor shall be calculated for each pollutant as follows:

$$D.E.F = \frac{Mi_2}{Mi_1}$$

Where:

Mi<sub>1</sub> = mass emission of the pollutant i in g/km after the type 1 test of a vehicle specified in clause 1.1.of this Chapter.

Mi<sub>2</sub> = mass emission of the pollutant i in g/km after the type test 1 of an aged vehicle according the procedure described in this Chapter.

These interpolated values shall be carried out to a minimum of four places to the right of the decimal point before dividing one by the other to determine the deterioration factor. The result shall be rounded to three places to the right of the decimal point.

If a deterioration factor is less than one, it is deemed to be equal to one

At the request of a manufacturer, an additive exhaust emission deterioration can be used, the factor shall be calculated for each pollutant as follows:

$$D. E. F. = M_{i2} - M_{i1}$$

## APPENDIX 4 TO CHAPTER 5

### Standard bench cycle (SBC)

#### 1.0 INTRODUCTION

The standard ageing durability procedure consists of ageing a catalyst/oxygen sensor system on an ageing bench which follows the standard bench cycle (SBC) described in this Appendix. The SBC requires use of an ageing bench with an engine as the source of feed gas for the catalyst. The SBC is a 60-second cycle which is repeated as necessary on the ageing bench to conduct ageing for the required period of time. The SBC is defined based on the catalyst temperature, engine air/fuel (A/F) ratio, and the amount of secondary air injection which is added in front of the first catalyst

#### 2.0 CATALYST TEMPERATURE CONTROL

- 2.1. Catalyst temperature shall be measured in the catalyst bed at the location where the highest temperature occurs in the hottest catalyst. Alternatively, the feed gas temperature may be measured and converted to catalyst bed temperature using a linear transform calculated from correlation data collected on the catalyst design and ageing bench to be used in the ageing process
- 2.2. Control the catalyst temperature at stoichiometric operation (1 to 40 seconds on the cycle) to a minimum of 800 °C ( $\pm 10$  °C) by selecting the appropriate engine speed, load, and spark timing for the engine. Control the maximum catalyst temperature that occurs during the cycle to 890 °C ( $\pm 10$  °C) by selecting the appropriate A/F ratio of the engine during the 'rich' phase described in the table below.
- 2.3. If a low control temperature other than 800 °C is utilized, the high control temperature shall be 90 °C higher than the low control temperature.

Standard bench cycle (SBC)		
Time (seconds)	Engine Air/Fuel Ratio	Secondary Air Injection
1-40	Stoichiometric with load, spark timing and engine speed controlled to achieve a minimum catalyst temperature of 800 °C	None
41-45	'Rich' (A/F ratio selected to achieve a maximum catalyst temperature over the entire cycle of 890 °C or 90 °C higher than lower control	None
45-55	'Rich' (A/F ratio selected to achieve a maximum catalyst temperature over the entire cycle of 890 °C or 90 °C higher than lower control temperature)	3 % ( $\pm 0,1$ %)
55-60	Stoichiometric with same load, spark timing and engine speed as used in the 1-40 sec period of the cycle	3 % ( $\pm 0,1$ %)



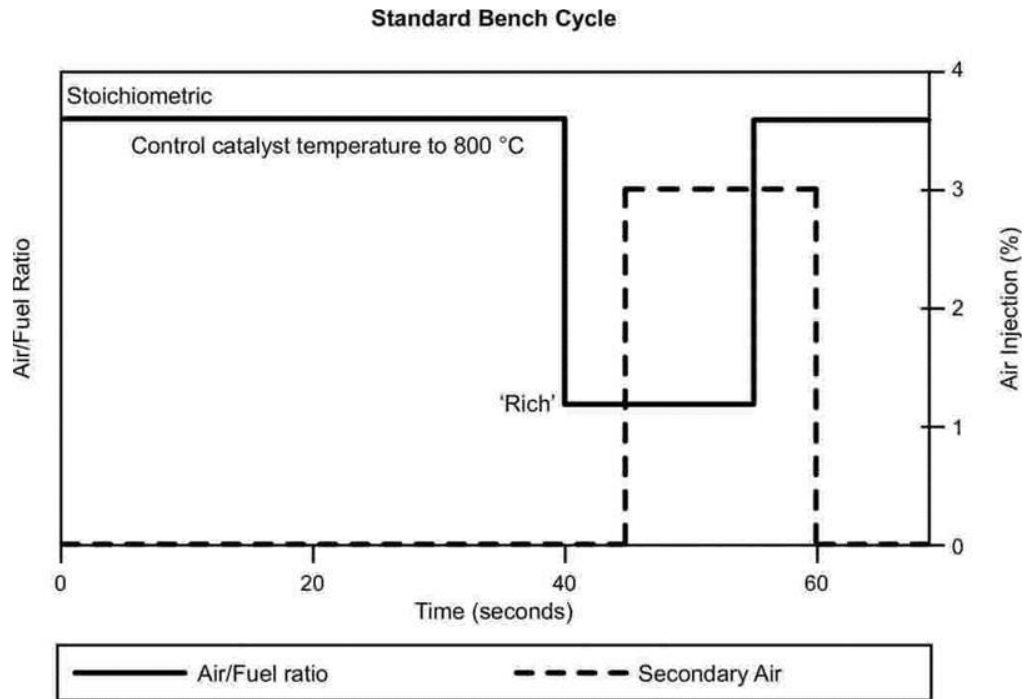

2.4 Type V test requirements for an L-category vehicle equipped with a hybrid propulsion

2.4.1 For OVC vehicles:

The electrical energy device / REESS may be charged twice a day during mileage accumulation.

For OVC vehicles with an operating mode switch, mileage accumulation shall be driven in the mode which is automatically set after the ignition key is turned (normal mode).

**CHAPTER 6****TEST TYPE VIII REQUIREMENTS: OBD STAGE I AND STAGE II ENVIRONMENTAL TESTS****1.0 INTRODUCTION**

- 1.1. This chapter prescribes the requirements for On-Board Diagnostic stage 1 (OBD I) and stage 2 (OBD II) systems for vehicles to detect, and, if applicable, record and/or communicate failures of specific vehicle and engine systems that affect the environmental performance of these systems, as described in the specific appendices to this appendix.

This chapter also refers to the OBD II threshold limits set out in the notification.

- 1.2. In addition, this chapter specifies the elements concerning the OBD system to facilitate the diagnosis, efficient and effective repair and maintenance of specific vehicle and engine systems without containing mandatory prescriptions for this purpose.
- 1.3. OBD should not oblige manufacturers to change or add fueling or ignition hardware and should not impose fitting of an electronic carburetor, electronic fuel injection or electronically controlled ignition coils, providing the vehicle complies with the applicable environmental performance requirements. Compliance with the OBD requirements implies that if fuel delivery, spark delivery or intake air hardware is electronically controlled, the applicable input or output circuits need to be monitored, limited to the items and failure modes listed in Table 2 of Appendix 1.1 of this Chapter and Table 2 of Appendix 1.2 of this chapter. In the case of a mechanical carburetor fitted with a throttle position sensor providing a circuit signal as input to the PCU / ECU to determine the engine load, which on its turn would be used to electronically control spark delivery, requires monitoring of that throttle position sensor circuit. Also other sensors or actuator circuits listed in Table 2 of Appendix 1.1 & Table 2 of Appendix 2.1 of this chapter shall be monitored although not directly used to control fuel delivery, spark delivery or intake air control. An example of such a case would be the wheel speed sensor circuits in case the vehicle speed would be calculated in the PCU / ECU from the wheel rotation speeds and which would be used as input to control the environmental performance of the vehicle.
- 1.4. The Malfunction Indicator (MI) activation performance criteria are prescribed in Table 1 of Appendix 1.2 of this chapter for OBD I and Table 1 of Appendix 2.2 of this chapter for OBD II.

**2.0 SCOPE AND APPLICATION**

Scope of this Chapter covers vehicles using the test fuel as defined in sub-rule 19 (i) of the CMV Rule 115.

**3.0 DEFINITIONS: ( REFER OVERALL REQUIREMENTS)**

**4.0 LIST OF ACRONYMS AND SYMBOLS: refer appendix 1 to chapter 2**

**5.0 GENERAL REQUIREMENT**

5.1. Vehicles, systems and components shall be so designed, constructed and assembled by the manufacturer, so as to enable the vehicle, in normal use and maintained according to the prescriptions of the manufacturer, to comply with the provisions of this chapter during its useful life.

**5.2. BI-FUELLED GAS VEHICLES**

In general, all the OBD requirements applying to a mono-fuelled vehicle apply to bi-fuelled gas vehicles for each of the fuel types (as per CMV Rule 115 (19(i))). To this end, one of the following two alternatives in Clauses 5.2.1. or 5.2.2. of this Chapter or any combination thereof shall be used.

5.2.1. One OBD system for both fuel types

5.2.1.1. The following procedures shall be executed for each diagnostic in a single OBD system for operation on fuel types (as per CMV Rule 115 (19(i))), either independent of the fuel currently in use or fuel type specific:

- (a) Activation of Malfunction Indicator (MI) (see Clause 1.4.5. of this Chapter);
- (b) Diagnostic trouble code storage (see Clause 1.4.6. of this Chapter);
- (c) Extinguishing the MI (see Clause 1.4.7. of this Chapter);
- (d) Erasing a diagnostic trouble code (see Clause 1.4.8. of this Chapter).

For components or systems to be monitored, either separate diagnostics for each fuel type can be used or a common diagnostic.

5.2.1.2. The OBD system can reside in either one or more computers.

5.2.2. Two separate OBD systems, one for each fuel type.

5.2.2.1. The following procedures shall be executed independently of each other when the vehicle is operated on fuel types (as per CMV Rule 115 (19(i))):

- (a) Activation of Malfunction Indicator (MI) (see Clause 1.4.5. of this Chapter);

- (b) Diagnostic trouble code storage (see Clause 1.4.6. of this Chapter);
  - (c) Extinguishing the MI (see Clause 1.4.7. of this Chapter);
  - (d) Erasing a diagnostic trouble code (see Clause 1.4.8. of this Chapter).
- 5.2.2.2. The separate OBD systems can reside in either one or more computers.
- 5.2.3. Specific requirements regarding the transmission of diagnostic signals from bi-fuelled gas vehicles.
- 5.2.3.1. On a request from a diagnostic scan tool, the diagnostic signals shall be transmitted on one or more source addresses. The use of source addresses is set out in ISO 15031-5:2011.
- 5.2.3.2. Identification of fuel specific information can be realised as follows:
- (a) By use of source addresses;
  - (b) By use of a fuel select switch;
  - (c) By use of fuel specific diagnostic trouble codes.

- 5.2.4. Regarding the status code (described in Clause 1.4.6. of this Chapter), one of the following two alternatives has to be used if one or more of the diagnostics reporting readiness is fuel type specific:

The status code is fuel specific, i.e. use of two status codes, one for each fuel type;

The status code shall indicate fully evaluated control systems for fuel types (as per CMV Rule 115 (19(i))) when the control systems are fully evaluated for one of the fuel types.

If none of the diagnostics reporting readiness is fuel-type specific, only one status code has to be supported.

5.3. **Requirements relating to the approval of on-board diagnostic systems**

- 5.3.1. A manufacturer may ask the test agency to accept an OBD system for approval even if the system contains one or more deficiencies so that the specific requirements of this appendix are not fully met.

- 5.3.2. In considering the request, the test agency shall determine whether compliance with the requirements of this appendix is unfeasible or unreasonable.

The test agency shall take into consideration data from the manufacturer detailing factors such as, but not limited to, technical feasibility, lead time and production cycles including phase-in or phase-out of engines or vehicle designs and programmed upgrades of computers, the extent to which the resultant OBD system will be effective in complying with

the requirements of this appendix and whether the manufacturer has demonstrated an acceptable level of effort to comply with those requirements.

5.3.2.1. The test agency shall not accept any deficiency request that includes the complete lack of a required diagnostic monitor.

5.3.3. Prior to, or at the time of, approval, no deficiency shall be granted in respect of the requirements of Clause 3 of Appendix 1.1, except Clause 3.11 of Appendix 1.1 of this Chapter.

5.3.4 **DEFICIENCY PERIOD**

5.3.4.1. A deficiency may be carried over for a period of two years after the date of approval of the vehicle type unless it can be adequately demonstrated that substantial vehicle hardware modifications and additional lead-time beyond two years would be necessary to correct it. In such a case, it may be carried over for a period not exceeding three years.

5.3.4.2. A manufacturer may ask the test agency to grant a deficiency retrospectively when it is discovered after the original approval. In this case, the deficiency may be carried over for a period of two years after the date of notification to the test agency unless it can be adequately demonstrated that substantial vehicle hardware modifications and additional lead-time beyond two years would be necessary to correct it. In such a case, it may be carried over for a period not exceeding three years.

5.4. **PROPULSION FAMILY DEFINITION WITH REGARD TO OBD AND IN PARTICULAR TO TEST TYPE VIII**

5.4.1. A representative parent vehicle shall be selected to test and demonstrate to the test agency the functional on-board diagnostic requirements set out in Appendix 1.1 and 2.1 and to verify the test Type VIII requirements laid down in Appendix 1-3 and 2-3 and the propulsion family definition laid down in Chapter 7. All members of the family shall comply with the applicable requirements set out in this appendix.

5.5. **DOCUMENTATION**

The vehicle manufacturer shall complete the information document in accordance with the items listed in Appendix 1-4 and 2-4 and submit it to the test agency.

**APPENDIX 1 TO CHAPTER 6****OBD STAGE 1****1.0 OBD STAGE I**

1.1. The technical requirements of this Appendix shall be mandatory for vehicles in the scope of this appendix equipped with an OBD stage I system.

1.2. The OBD Stage I System Shall Monitor For Any Electric Circuit And Electronics Failure Of The Vehicle's Control System Laid Down In Appendix 1.2 Of This Chapter.

**1.3. Electric Circuit Diagnostic**

1.3.1. For the purposes of Clause 1.4.3.3. of this Appendix, the electric circuit and electronic failure diagnostics with regard to OBD stage I shall at a minimum contain the sensor and actuator diagnostics as well as the internal diagnostics of the electronic control units required in Appendix 1.2 of this Chapter.

**1.4. Functional OBD Requirements**

1.4.1. Vehicles in the scope of this appendix shall be equipped with an OBD stage I system so designed, constructed and installed in a vehicle as to enable it to identify types of malfunction over the useful life of the vehicle.

1.4.1.1. Access to the OBD system related data required for the inspection, diagnosis, servicing or repair of the vehicle shall be unrestricted and standardised. All OBD relevant diagnostic trouble codes shall be consistent with Clause 3.11. of Appendix 1.1 of this Chapter.

1.4.1.2. At the manufacturer's discretion, to aid technicians in the efficient repair of vehicles, the OBD system may be extended to monitor and report on any other on-board system. Extended diagnostic systems shall not be considered as falling under the scope of approval requirements.

1.4.2. The OBD system shall be so designed, constructed and installed in a vehicle as to enable it to comply with the requirements of this appendix during conditions of normal use.

1.4.2.1. Temporary disablement of the OBD system

1.4.2.1.1. A manufacturer may disable the OBD system at ambient engine starting temperatures below  $-7^{\circ}\text{C}$  or at elevations over 2500 metres above sea level, provided it submits data or an engineering evaluation which adequately demonstrate that monitoring would be unreliable in such conditions. It may also request disablement of the OBD system at other ambient engine starting temperatures if it demonstrates to the test agency with data or an engineering evaluation that misdiagnosis would occur under such conditions.

- 1.4.2.1.2. For vehicles designed to accommodate the installation of power take-off units, disablement of affected monitoring systems is permitted provided disablement occurs only when the power take-off unit is active.
- 1.4.2.1.3. The manufacturer may temporarily disable the OBD system in the following conditions:
  - (a) For flex-fuel or mono/bi-fuel gas vehicles for one minute after re-fuelling to allow for the recognition of fuel quality and composition by the Powertrain Control Unit(s) (PCU);
  - (b) For bi-fuel vehicles for five seconds after fuel switching to allow for engine parameters to be readjusted;
  - (c) The manufacturer may deviate from these time limits if it can be demonstrated that stabilisation of the fuelling system after re-fuelling or fuel switching takes longer for justified technical reasons. In any case, the OBD system shall be re-enabled as soon as either the fuel quality or composition is recognised or the engine parameters are readjusted.
- 1.4.3. The OBD system shall monitor for:
  - 1.4.3.1. At a minimum, the electric / electronic circuits required in Appendix 1.2 of this Chapter.
  - 1.4.3.2. If active on the selected fuel, other emission controls system components or systems, or emission-related powertrain components or systems, which are connected to a computer.
  - 1.4.3.3. Unless otherwise monitored, any other electronic powertrain component connected to a computer relevant for environmental performance and/or functional safety, including any relevant sensors to enable monitoring functions to be carried out, shall be monitored for electric / electronic circuit failures. In particular, these electronic components shall be continuously monitored for any electric circuit continuity failure, and shorted electric circuits of the control system in accordance with Appendix 1.2 of this Chapter.
- 1.4.4. A sequence of diagnostic checks shall be initiated at each engine start and completed at least once provided that the correct test conditions are met.
- 1.4.5. **Activation of the Malfunction Indicator (MI)**
  - 1.4.5.1. The OBD system shall incorporate a malfunction indicator readily perceivable to the vehicle operator. The MI shall not be used for any purposes other than to indicate emergency start-up or limp-home routines to the driver. The MI shall be visible in all reasonable lighting conditions. When activated, it shall display a symbol in conformity with AIS 126, symbol F.01. A vehicle shall not be equipped with more than one general purpose MI used to convey power-train related failures which may affect emissions or limp home mode. Separate specific purpose tell tales (e. g. brake system, oil pressure, etc.) are permitted. The use of red colour for a MI is prohibited.

- 1.4.5.2. For strategies requiring more than two preconditioning cycles for MI activation, the manufacturer shall provide data or an engineering evaluation which adequately demonstrate that the monitoring system is equally effective and timely in detecting component deterioration. Strategies requiring on average more than ten driving cycles for MI activation are not accepted.
- 1.4.5.3. The MI shall also activate when the vehicle's ignition is in the "key-on" position before engine starting or cranking and deactivate if no malfunction has been detected. For vehicles not equipped with a battery, the MI shall illuminate immediately after engine starting and shall subsequently be deactivated after 5 seconds, if no malfunction has previously been detected.
- 1.4.6. The OBD system shall record diagnostic trouble code(s) indicating the status of the control system. Separate status codes shall be used to identify correctly functioning control systems and those control systems which need further vehicle operation to be fully evaluated. If the MI is activated due to malfunction or permanent default modes of operation, a diagnostic trouble code shall be stored that identifies the type of malfunction. A diagnostic trouble code shall also be stored in the cases referred to in Clause 1.4.3.3 of this Chapter.
  - 1.4.6.1. The distance travelled by the vehicle while the MI is activated shall be available at any moment through the serial port on the standardised diagnostic connector. By means of derogation for vehicles equipped with a mechanically operating odometer that does not allow input to the electronic control unit, "distance travelled" may be replaced with "engine operation time" and shall be made available at any moment through the serial port on the standardised diagnostic connector. Engine operation time in this context means the total accumulated time in which the propulsion unit(s) provide(s) mechanical output (e.g. the crankshaft of a combustion engine rotates) after triggering the MI activation during one or more key cycles.
- 1.4.7. **Extinguishing the MI**
  - 1.4.7.1. For all malfunctions, the MI may be deactivated after three subsequent sequential driving cycles during which the monitoring system responsible for activating the MI ceases to detect the malfunction and if no other malfunction has been identified that would independently activate the MI.
- 1.4.8. Erasing a diagnostic trouble code
  - 1.4.8.1. The OBD system may erase a diagnostic trouble code and the distance travelled and freeze-frame information if the same fault is not re-registered in at least 40 engine warm-up cycles.
  - 1.4.8.2. Stored faults shall not be erased by disconnection of the on-board computer from the vehicle power supply or by disconnection or failure of the vehicle battery or batteries.



## APPENDIX 1.1 TO CHAPTER 6

### FUNCTIONAL ASPECTS OF ON-BOARD DIAGNOSTIC (OBD) STAGE I SYSTEMS

#### 1.0 INTRODUCTION

The on-board diagnostic stage I systems fitted on vehicles in the scope of this appendix shall comply with the detailed information and functional requirements and verify if the system is capable of meeting the functional part of the on-board diagnostic requirements.

#### 2.0 ON-BOARD DIAGNOSTIC FUNCTIONAL VERIFICATION TESTING

- 2.1. The on-board diagnostic environmental system performance and the functional OBD capabilities shall be verified and demonstrated to the test agency by performing the Type VIII test procedure referred to in Appendix 1.3 of this Chapter.

#### 3.0 DIAGNOSTIC SIGNALS

- 3.1. Upon determination of the first malfunction of any component or system, at the manufacturer's choice, "freeze-frame" engine conditions present at the time shall be stored in computer memory in accordance with the specifications in Clause 3.10 of this Appendix. Stored engine conditions shall include, but are not limited to, calculated load value, engine speed, fuel trim value(s) (if available), fuel pressure (if available), vehicle speed (if available), coolant temperature (if available), intake manifold pressure (if available), closed- or open-loop operation (if available) and the diagnostic trouble code which caused the data to be stored.

- 3.1.1. The manufacturer shall choose the most appropriate set of conditions facilitating effective and efficient repairs in freeze-frame storage. Only one frame of data is required. Manufacturers may choose to store additional frames provided that at least the required frame can be read by a generic scan tool meeting the specifications of Clauses 3.9 and 3.10 of this Appendix. If the diagnostic trouble code causing the conditions to be stored is erased in accordance with Clause 1.4.8.1. of Appendix 1 of this Chapter, the stored engine conditions may also be erased.

- 3.1.2. The calculated load value shall be calculated as follows:

Equation 1:

$$CLV = \frac{\text{Current\_airflow}}{\text{Peak\_airflow(at\_sea\_level)}} \cdot \frac{\text{Atmospheric\_pressure\_ (at\_sea\_level)}}{\text{Barometric\_pressure}}$$

- 3.1.3. Alternatively, the manufacturer may choose another appropriate load variable of the propulsion unit (such as throttle position, intake manifold pressure, etc.) and shall demonstrate that the alternative load variable correlates well with calculated load variable set out in Clause 3.1.2. of this Appendix [And is in accordance with the specifications in Clause 3.10. of this Appendix].
- 3.2. If available, the following signals in accordance with the specifications in Clause 3.10. of this Appendix, in addition to the required freeze-frame information at the manufacturer's choice, shall be made available on demand through the serial port on the standardised diagnostic connector, if the information is available to the on-board computer or can be determined using information available to the on-board computer: number of stored diagnostic trouble codes, engine coolant temperature, fuel control system status (closed-loop, open-loop, other), fuel trim, ignition timing advance, intake air temperature, manifold air pressure, air flow rate, engine speed, throttle position sensor output value, secondary air status (upstream, downstream or atmosphere), calculated load value, vehicle speed, and fuel pressure.  
  
The signals shall be provided in standard units based on the specifications in Clause 3.10 of this Appendix. Actual signals shall be clearly identified separately from default value or limp-home signals.
- 3.3. Reserved
- 3.4. The OBD requirements to which the vehicle is certified and the major control systems monitored by the OBD system in accordance with the specifications in Clause 3.10 of this Appendix shall be made available through the serial data port on the standardised diagnostic data link connector according to the specifications in Clause 3.8 of this Appendix.
- 3.5. The software identification (calibration identification number) and calibration verification numbers shall be made available through the serial port on the standardised diagnostic data link connector. Both numbers shall be provided in a standardised format in accordance with the specifications in Clause 3.10 of this Appendix.
- 3.6. The diagnostic system is not required to evaluate components during malfunction if such evaluation would result in a risk to safety or component failure.
- 3.7. The diagnostic system shall provide for standardised and unrestricted access to OBD and conform to the following ISO standards or SAE specification:
- 3.8. One of the following standards with the restrictions described shall be used as the on-board to off-board communications link:

ISO 9141-2:1994/Amd 1:1996: "Road Vehicles — Diagnostic Systems — Part 2: CARB requirements for interchange of digital information";

SAE J1850: March 1998 "Class B Data Communication Network Interface. Emission related messages shall use the cyclic redundancy check and the three-byte header and not use inter byte separation or checksums";

ISO 14229-3:2012: "Road vehicles — Unified Diagnostic Services (UDS) — Part 3: Unified diagnostic services on CAN implementation";

ISO 14229-4:2012: "Road vehicles — Unified diagnostic services (UDS) — Part 4: Unified diagnostic services on Flex Ray implementation";

ISO 14230-4:2000: "Road Vehicles — Keyword protocol 2000 for diagnostic systems — Part 4: Requirements for emission-related systems";

ISO 15765-4:2011: "Road vehicles — Diagnostics on Controller Area Network (CAN) — Part 4: Requirements for emissions-related systems", dated 1 November 2001;

ISO 22901-2:2011: "Road vehicles — Open diagnostic data exchange (ODX) — Part 2: Emissions-related diagnostic data".

- 3.9. Test equipment and diagnostic tools needed to communicate with OBD systems shall meet or exceed the functional specification in ISO 15031-4:2005: "Road vehicles — Communication between vehicle and external test equipment for emissions-related diagnostics — Part 4: External test equipment".
- 3.10. Basic diagnostic data (as specified in Clause 3 of this Appendix.) and bi-directional control information shall be provided using the format and units described in ISO 15031-5:2011 "Road vehicles — Communication between vehicle and external test equipment for emissions-related diagnostics — Part 5: Emissions-related diagnostic services" and shall be available using a diagnostic tool meeting the requirements of ISO 15031-4:2005.
  - 3.10.1. The vehicle manufacturer shall provide the test agency with details of any diagnostic data, e.g. PIDs, OBD monitor IDs, Test IDs not specified in ISO 15031-5:2011 but relating to this Appendix.
- 3.11. When a fault is registered, the manufacturer shall identify the fault using an appropriate diagnostic trouble code consistent with those in Section 6.3. of ISO 15031-6:2010 "Road vehicles — Communication between vehicle and external test equipment for emissions-related diagnostics — Part 6: Diagnostic trouble code definitions" relating to "emission related system diagnostic trouble codes". If this is not possible, the manufacturer may use the diagnostic trouble codes in Sections 5.3. and 5.6. of ISO DIS 15031-6:2010. Alternatively,

diagnostic trouble codes may be compiled and reported according to ISO 14229:2006. The diagnostic trouble codes shall be fully accessible by standardised diagnostic equipment complying with Clause 3.9 of this Appendix.

- 3.11.1. The vehicle manufacturer shall provide to a national standardisation body the details of any emission-related diagnostic data, e.g. PIDs, OBD monitor IDs, Test IDs not specified in ISO 15031-5:2011 or ISO14229:2006, but relating to this Appendix.
- 3.12. The connection interface between the vehicle and the diagnostic tester shall be standardised and meet all the requirements of ISO [DIS] 19689:2016 "Motorcycles and Mopeds — Communication between vehicle and external equipment for diagnostics — Diagnostic connector and related electrical circuits, specification and use" or ISO 15031-3:2004 "Road vehicles — Communication between vehicle and external test equipment for emissions-related diagnostics — Part 3: Diagnostic connector and related electric circuits: specification and use". The preferred installation position is under the seating position. Any other position of the diagnostic connector shall be subject to the test agency's agreement and be readily accessible by service personnel but protected from tampering by non-qualified personnel. The position of the connection interface shall be clearly indicated in the user manual.
- 3.13. Until a standardised connection interface for L2-category vehicles has been adopted and published at ISO or CEN level and the reference of that technical standard is included in this Part, an alternative connection interface may be installed at the request of the vehicle manufacturer. Where such an alternative connection interface is installed, the vehicle manufacturer shall make available to test equipment manufacturers the details of the vehicle connector pin configuration free of charge. The vehicle manufacturer shall provide an adapter enabling connection to a generic scan tool. Such an adapter shall be of suitable quality for professional workshop use. It shall be provided upon request to all independent operators in a non-discriminating manner. Manufacturers may charge a reasonable and proportionate price for this adapter, taking into account the additional costs caused for the customer by this choice of the manufacturer. The connection interface and the adapter may not include any specific design elements which would require validation or certification before use, or which would restrict the exchange of vehicle data when using a generic scan tool.

#### **4.0 ACCESS TO OBD INFORMATION**

- 4.1. Applications for approval or its amendments shall be accompanied by the repair information concerning the vehicle OBD system. This information shall enable manufacturers of replacement or retrofit components to make the parts they manufacture compatible with the vehicle OBD system, with a view to fault-free operation assuring the vehicle user against malfunctions. Similarly, such repair information shall enable the manufacturers of diagnostic tools and test equipment to make tools and equipment that provide for the effective and accurate diagnosis of vehicle control systems.

- 4.2. Upon request, the vehicle manufacturer shall make the repair information on the OBD system available to any interested components, diagnostic tools or test equipment manufacturer on a non-discriminatory basis:
  - 4.2.1. A description of the type and number of preconditioning cycles used for the original approval of the vehicle;
  - 4.2.2. A description of the type of the OBD demonstration cycle used for the original approval of the vehicle for the component monitored by the OBD system;
  - 4.2.3. A comprehensive document describing all sensed components with the strategy for fault detection and MI activation (fixed number of driving cycles or statistical method), including a list of relevant secondary sensed parameters for each component monitored by the OBD system and a list of all OBD output codes and format used (with an explanation of each) associated with individual emission related powertrain components and individual non-emission related components, where monitoring of the component is used to determine MI activation.
  - 4.2.4. This information may be provided in the form of a table, as follows:

**Table 1:  
Template OBD information list**

<i>Component</i>	<i>Diagnostic trouble code</i>	<i>Monitoring strategy</i>	<i>Fault detection criteria</i>	<i>MI activation criteria</i>	<i>Secondary parameters</i>	<i>Preconditioning</i>	<i>Demonstration test</i>	<i>Default mode</i>
Cat alys t	P04 20	Oxyg en sen sor 1 and 2 signa ls	Difference between sensor 1 and sensor 2 signals	3rd cyc le	Engine speed, engine load, A/F mode, catalyst temperatu re	Two Typ e I cycl es	Typ e I	No ne

- 4.2.5. If the test agency receives a request from any interested components, diagnostic tools or test equipment manufacturer for information on the OBD system of a vehicle that has been Type approved by that test agency

That test agency shall, within 30 days, ask the manufacturer of the vehicle in question to make available the information required in Clauses 4.1. and 4.2 of this Appendix;

The vehicle manufacturer shall submit this information to that test agency within two months of the request;

That test agency shall transmit this information and shall attach this information to the vehicle approval information.

- 4.2.6. Information can be requested only for replacement or service components that are subject to approval or for components that form part of a system subject to approval.

- 4.2.7. The request for repair information shall identify the exact specification of the vehicle model for which the information is required. It shall confirm that the information is required for the development of replacement or retrofit parts or components or diagnostic tools or test equipment.

- 4.2.8. Access to vehicle security features used by authorised dealers and repair shops shall be made available to independent operators under protection of security technology according to the following requirements:

Data shall be exchanged ensuring confidentiality, integrity and protection against replay;

The standard https//ssl-tls (RFC4346) shall be used;

Security certificates in accordance with ISO 20828 shall be used for mutual authentication of independent operators and manufacturers;

The independent operator's private key shall be protected by secure hardware.

- 4.2.8.1. The independent operator shall be approved and authorized for this purpose on the basis of documents demonstrating that they pursue a legitimate business activity and have not been convicted of relevant criminal activity.

**APPENDIX 1.2 TO CHAPTER 6  
MINIMUM MONITORING REQUIREMENTS FOR AN  
ON-BOARD DIAGNOSTIC (OBD) SYSTEM STAGE I**

**1.0 INTRODUCTION**

The following minimum monitoring requirements shall apply for OBD systems complying with the requirements of OBD stage I regarding electric circuit diagnostics.

**2.0 MONITORING REQUIREMENTS**

2.1. If fitted, the following listed sensors and actuators shall be monitored for electric circuit malfunctions.

**Table 1 :  
Scope of OBD stage I**

Items	Scope of OBD I
Table 2 of same Appendix and chapter	yes
Any other sensor or actuator circuit declared by the manufacturer and part of the emission control system	yes
OBD fail thresholds	no

2.2. At a minimum the monitored devices with mandatory circuit diagnostics shall be the following :

**Table 2  
Overview of devices (if fitted) to be monitored in OBD stage I**

No.	Device circuits		Circuit continuity			Comment No.
			<i>Circuit High</i>	<i>Circuit Low</i>	<i>Open Circuit</i>	
		<i>Level, refer to 2.3.</i>				
1	Control module (ECU / PCU) internal error	3				(1)

Sensor (input to control units)						
1	Accelerator (pedal / handle) position sensor	1 & 3	I	I	I	( <sup>2</sup> )
2	Barometric pressure sensor	1	I	I	I	
3	Camshaft position sensor	3				
4	Crankshaft position sensor	3				
5	Engine coolant temperature sensor	1	I	I	I	
6	Exhaust control valve angle sensor	1	I	I	I	
7	Exhaust gas recirculation sensor	1 & 3	I	I	I	
8	Fuel rail pressure sensor	1	I	I	I	
9	Fuel rail temperature sensor	1	I	I	I	
10	Gear shift position sensor (potentiometer type)	1	I	I	I	
11	Gear shift position sensor (switch type)	3				
12	Intake air temperature sensor	1	I	I	I	
13	Knock sensor (Non- resonance type)	3				
14	Knock sensor (Resonance type)	3				
15	Manifold absolute pressure sensor	1	I	I	I	
16	Mass air flow sensor	1	I	I	I	
17	Engine oil temperature sensor	1	I	I	I	



18	O2 exhaust sensor (binary / linear) signals	1	I	I	I	
19	Fuel (high) pressure sensor	1	I	I	I	
20	Fuel storage temperature sensor	1	I	I	I	
21	Throttle position sensor	1&3	I	I	I	( <sup>2</sup> )
22	Vehicle speed sensor	3				( <sup>3</sup> )
23	Wheel speed sensor	3				( <sup>3</sup> )
<b>Actuators (output control units)</b>						
1	Evaporative emission system purge control valve	2		I		
2	Exhaust control valve actuator (motor driven)	3				
3	Exhaust gas recirculation control	3				
4	Fuel injector	2		I		( <sup>4</sup> )
5	Idle air control system	1	I	I	I	( <sup>4</sup> )
6	Ignition coil primary control circuits	2		I		( <sup>4</sup> )
7	O <sub>2</sub> exhaust sensor heater	1	I	I	I	( <sup>4</sup> )
8	Secondary air injection system	2		I		( <sup>4</sup> )
9	Throttle by wire actuator	3		I		( <sup>4</sup> )

- (<sup>1</sup>) Only in case of an activated limp-home mode or if a throttle by wire system is fitted.
- (<sup>2</sup>) If there is only one APS or TPS fitted, APS or TPS circuit rationality monitoring is not mandatory.
- (<sup>3</sup>) Only if used as input to ECU / PCU with relevance to environmental performance or when the OBD system fault triggers a limp-home mode.
- (<sup>4</sup>) Derogation allowed if manufacturer requests, level 3 instead, actuator signal present only without indication of symptom.

- 2.3. If there are more of the same device types fitted on the vehicle listed in Table 2 of this Appendix, those devices shall be separately monitored and reported in case of malfunctions. If a malfunction is marked with "I" in Table 2 of this Appendix it shall mean that monitoring is mandatory for OBD stage I.
- 2.4. Sensors and actuators shall be associated with a specific diagnostic level that defines which type of diagnostic monitoring shall be performed as follows:
  - 2.4.1. **Level 1:** sensor/actuator of which at least two circuit continuity symptoms can be detected and reported (i.e. short circuit to ground, short circuit to power and open circuit).
  - 2.4.2. **Level 2:** sensor/actuator of which at least one circuit continuity symptom can be detected and reported (i.e. short circuit to ground, short circuit to power and open circuit).
  - 2.4.3. **Level 3:** sensor/actuator of which at least one symptom can be detected, but not reported separately.
- 2.5. **Exemptions regarding detection**

Exemption from detecting certain electric circuit monitoring symptoms may be granted if the manufacturer can demonstrate to the satisfaction of the test agency that the only feasible monitoring strategy would negatively affect vehicle safety or driveability in a significant way.

2.6. **Exemption regarding OBD verification tests (test Type VIII)**

At the request of the manufacturer and based on a technical justification to the satisfaction of the test agency, certain OBD monitors listed in Table 2 of this Appendix may be exempted from test Type VIII verification tests referred to in Appendix 1.3 of this chapter under the condition that the manufacturer can demonstrate to test agency that:

- 2.6.1. The malfunction indicator fitted to the vehicle is activated when the malfunction listed in Table 2 of this Appendix occurs:
  - 2.6.1.1. During the same key cycle and;
  - 2.6.1.2. Immediately after expiration of a limited time delay (300 s or less) in that same key cycle; or
- 2.6.2. Monitoring of some of the items listed in Table 2 of this Appendix is physically not possible and a deficiency has been granted for this incomplete monitor. The comprehensive, technical justification why such an OBD monitor cannot run shall be added to the information folder.

**APPENDIX 1.3 TO CHAPTER 6**  
**TEST TYPE VIII, ON-BOARD DIAGNOSTIC ENVIRONMENTAL**  
**VERIFICATION TEST**

**1.0 INTRODUCTION**

- 1.1. This Appendix describes the procedure for Type VIII testing, On-Board Diagnostics (OBD) environmental verification testing, which is required for the approval of a vehicle complying with OBD stage I requirements. The procedure describes methods for checking the function of the OBD system on the vehicle by simulating failure of components in the powertrain management system and emission-control system.
- 1.2. The manufacturer shall make available the defective components or electrical devices to be used to simulate failures.
- 1.3. When the vehicle is tested with the defective component or device fitted, the OBD system shall be approved if the malfunction indicator is activated.

**2.0 OBD STAGE I**

**2.1 OBD stage I**

The test procedures in this Appendix shall be mandatory for L2-category vehicles equipped with an OBD stage I system. This obligation concerns compliance with all provisions of this appendix.

**3.0 DESCRIPTION OF TESTS**

- 3.1. The OBD system shall indicate the failure of any of the devices in accordance with Appendix 1.2 of this Chapter.
- 3.2. The test Type I data in the template for a test report including the used dynamometer settings and applicable emission laboratory test cycle shall be provided for reference.
- 3.3. The list with PCU / ECU malfunctions shall be provided :
- 3.3.1. For short descriptions of the test methods used to simulate the malfunctions, as referred to in Clause 4 of this Appendix.

**4.0 OBD ENVIRONMENTAL TEST PROCEDURE**

**4.1 The testing of OBD systems consists of the following phases:**

- 4.1.1. Simulation of malfunction of a component of the powertrain management or emission-control system;
- 4.1.2. Preconditioning of the vehicle (in addition to the preconditioning specified in Chapter 2) with a simulated malfunction.

- 4.1.3 Driving the vehicle with a simulated malfunction over the applicable Type I test cycle;
- 4.1.4. Determining whether the OBD system reacts to the simulated malfunction and alerts the vehicle driver to it in an appropriate manner.
- 4.2. Alternatively, at the request of the manufacturer, malfunction of one or more components may be electronically simulated in accordance with the requirements laid down in Clause 8 of this Appendix.
- 4.3. Manufacturers may request that monitoring take place outside the Type I test cycle if it can be demonstrated to the test agency that the monitoring conditions of the Type I test cycle would be restrictive when the vehicle is used in service.
- 4.4. For all demonstration testing, the Malfunction Indicator (MI) shall be activated before the end of the test cycle.

## **5.0 TEST VEHICLE AND FUEL**

### **5.1. Test vehicle**

The aged, test parent vehicle or a new vehicle fitted with defective components or electrical devices shall meet the propulsion unit family requirements laid down in Chapter 7.

- 5.2. The manufacturer shall set the system or component for which detection is to be demonstrated at or beyond the criteria limit prior to operating the vehicle over the test cycle appropriate for the classification of the vehicle. To determine correct functionality of the diagnostic system, the test vehicle shall then be operated over the appropriate Type I test cycle at the discretion of the manufacturer.

### **5.3. Test fuel**

The reference fuel to test the vehicle shall be as specified in the notification and be of the same specification as the reference fuel used to conduct the Type I tailpipe emissions after cold start. The selected fuel type shall not be changed during any of the test phases.

## **6.0 TEST TEMPERATURE AND PRESSURE**

- 6.1. The test temperature and ambient pressure shall meet the requirements of the specified Type I test.

## **7.0 TEST EQUIPMENT**

### **7.1. Chassis dynamometer**

The chassis dynamometer shall meet the requirements of Chapter 2.

**8.0 OBD ENVIRONMENTAL VERIFICATION TEST PROCEDURES****8.1 The operating test cycle on the chassis dynamometer shall meet the test Type I requirements.**

8.1.1. The Type I test need not be performed for the demonstration of electrical failures (short/open circuit). The manufacturer may demonstrate these failure modes using driving conditions in which the component is used and the monitoring conditions are encountered. Those conditions shall be documented in the Type approval documentation

**8.2 Vehicle preconditioning**

8.2.1. According to the propulsion type and after introduction of one of the failure modes referred to in Clause 8.3.of this Appendix, the vehicle shall be preconditioned by driving at least two consecutive appropriate Type I tests. For vehicles equipped with a compression ignition engine, additional preconditioning of two appropriate Type I test cycles is permitted.

8.2.2. At the request of the manufacturer, alternative preconditioning methods may be used.

8.2.3. The use of additional preconditioning cycles or alternative preconditioning methods shall be documented in the Type approval documentation.

**8.3 Failure modes to be tested**

8.3.1. For vehicles equipped with a Positive Ignition (PI) engine:

8.3.1.1. Electrical disconnection of any other component connected to a powertrain control unit / engine control unit (if active on the selected fuel type) in the scope of Appendix 1.2 of this Chapter;

8.3.1.2. Electrical disconnection of the electronic evaporative purge control device (if equipped and if active on the selected fuel type). For this specific failure mode, the Type I test need not be performed.

8.3.2. For vehicles equipped with a Compression Ignition (CI) engine:

8.3.2.1. Electrical disconnection of any electronic fuel quantity and timing actuator in the fuelling system;

8.3.2.2. Electrical disconnection or shorted circuit of any other relevant component connected to control computer of the powertrain;

8.3.3. The manufacturer shall take appropriate steps to demonstrate that the OBD system will indicate a fault when one or more of the faults occur listed in Appendix 1-2 of this chapter.

**8.4 OBD system environmental verification tests**

**8.4.1. Vehicles fitted with Positive Ignition (PI) engines:**

8.4.1.1. After vehicle preconditioning in accordance with Clause 8.2. of this Appendix, the test vehicle is driven over the appropriate Type I test.

8.4.1.2. The malfunction indicator shall activate before the end of this test under any of the conditions given in paragraphs 8.4.1.3. and 8.4.1.4. The test agency may substitute those conditions with others in accordance with paragraph 8.4.1.4. However, the total number of failures simulated shall not exceed four for the purpose of approval.

For bi-fuelled gas vehicles, both fuel types shall be used within the maximum of four simulated failures at the discretion of the test agency.

8.4.1.3. Electrical disconnection of the electronic evaporative purge control device (if equipped and if active on the selected fuel type);

8.4.1.4. Electrical disconnection of any other component connected to a powertrain control unit / engine control unit / drive train control unit in the scope of Appendix 1-2.

**8.4.2. Vehicles fitted with Compression Ignition (CI) engines:**

8.4.2.1. After vehicle preconditioning in accordance with paragraph 8.2., the test vehicle is driven in the applicable type I test.

The malfunction indicator shall activate before the end of this test. The test agency may substitute those conditions by others in accordance with paragraph 8.4.2.2. However, the total number of failures simulated shall not exceed four for the purposes of approval.

8.4.2.2. Electrical disconnection of any other component connected to a powertrain control unit / engine control unit / drive train control unit in the scope of Appendix 1-2.

**APPENDIX 1.4 TO CHAPTER 6**  
**ADMINISTRATIVE PROVISIONS**

**1.0** The vehicle manufacturer shall fill out the information and submit to the test agency with regard to functional on-board diagnostics and test Type VIII according to the following template.

**2.0** Where documents, diagrams or long descriptions are required the vehicle manufacturer shall attach those as a separate file, appropriately marked in a clear and understandably system and the marking shall be written / typed for all sheets in the space provided.

The following data shall be provided by the vehicle manufacturer.

**2.1. On-board diagnostics (OBD) functional requirements**

**2.1.1. OBD system general information**

2.1.1.1. Written description or drawing of the Malfunction Indicator (MI);

**2.1.2. List and purpose of all components monitored by the OBD system:**

2.1.2.1. Written description (general working principles) for all OBD stage I circuit (open circuit, shorted low and high,) and electronics (PCU / ECU internal and communication) diagnostics which triggers a default mode in case of fault detection;

2.1.2.2. Written description (general working principles) for all OBD stage I diagnostic functionality triggering any operating mode which triggers a limp-home mode in case of fault detection;

2.1.2.3. Written description of the communication protocol(s) supported;

2.1.2.4. Physical location of diagnostic-connector (add drawings and photographs);

2.1.2.5. Other components than the ones listed in Table 2 of Appendix 1.2 of this Chapter monitored by the OBD system;

2.1.2.6. Criteria for MI activation (fixed number of driving cycles or statistical method);

2.1.2.7. List of all OBD output codes and formats used (with explanation of each);

2.1.2.8. OBD compatibility for repair information

The following additional information shall be provided by the vehicle manufacturer to enable the manufacturer of OBD-compatible replacement or service parts, diagnostic tools and test equipment;

- 2.1.2.9. A description of the type and number of the pre-conditioning cycles used for the original approval of the vehicle.
- 2.1.2.10. A comprehensive document describing all sensed components concerned with the strategy for fault detection and MI activation (fixed number of driving cycles or statistical method). This shall, include a list of relevant secondary sensed parameters for each component monitored by the OBD system. The document shall also list all OBD output codes and formats (with an explanation of each) used in association with individual emission-related powertrain components and individual non-emission-related components, where monitoring the component is used to determine MI activation.
- 2.1.2.11. The information required in Clauses 2.1.2.1. to 2.1.2.10. of this Appendix may be provided in table form as described in the following table;

**Table1  
Example OBD fault-code overview list**

Component	Diagnostic trouble code	Monitoring strategy	Fault detection criteria	MI activation criteria	Secondary parameters	Preconditioning	Demonstration test
Intake air temp. sensor open circuit	P0xx xxzz	Comparison with temperature model after cold start	> 20 degrees difference between measured and modelled intake air temperature	3 <sup>rd</sup> cycle	Coolant and intake air temperature sensor signals	Two Type I cycles	Type I

- 2.1.2.12. Description of Electronic Throttle Control (ETC) diagnostic trouble codes;
- 2.1.2.13. Description of default modes and strategies in case of ETC failure;
- 2.1.2.14. Communication protocol information

The following information shall be referenced to a specific vehicle make, model and variant, or identified using other workable definitions such as the Vehicle Identification Number (VIN) or vehicle and systems identification:



- 2.1.2.14.1. Any protocol information system needed to enable complete diagnostics in addition to the standards prescribed in Clause 3.8. of Appendix 1.1 of this Chapter, such as additional hardware or software protocol information, parameter identification, transfer functions, "keep alive" requirements, or error conditions;
- 2.1.2.14.2. Details of how to obtain and interpret all diagnostic trouble codes not in accordance with the standards prescribed in Clause 3.11. of Appendix 1.1 of this Chapter;
- 2.1.2.14.3. A list of all available live data parameters including scaling and access information;
- 2.1.2.14.4. A list of all available functional tests including device activation or control and the means to implement them;
- 2.1.2.14.5. Details of how to obtain all component and status information, time stamps, pending DTC and freeze frames;
- 2.1.2.14.6. Resetting adaptive learning parameters, variant coding and replacement component setup, and customer preferences;
- 2.1.2.14.7. PCU / ECU identification and variant coding;
- 2.1.2.14.8. Details of how to reset service lights;
- 2.1.2.15. Location of diagnostic connector and connector details;
- 2.1.2.16. Engine code identification;
- 2.1.2.17. Test and diagnosis of OBD monitored components:
  - 2.1.2.17.1. A description of tests to confirm its functionality, at the component or in the harness;
  - 2.1.2.17.2. Test procedure including test parameters and component information;
  - 2.1.2.17.3. Connection details including minimum and maximum input and output and driving and loading values;
  - 2.1.2.17.4. Electrical values for the component in its static and dynamic states;
  - 2.1.2.17.5. Failure mode values for each of the above scenarios;
  - 2.1.2.17.6. Failure mode diagnostic sequences including fault trees and guided diagnostics elimination.
- 2.1.3. **On-Board Diagnostics Environmental test type VIII Requirements**
  - 2.1.3.1. Details of test vehicle(s), its powertrain and pollution-control devices explicitly documented and listed, emission test laboratory equipment and settings.

**APPENDIX 2 TO CHAPTER 6  
OBD STAGE II**

**1.0 OBD STAGE II**

1.1 L2-category vehicle shall be equipped with an OBD stage II system if the manufacturer so chooses.

1.2 Where an OBD stage II system is fitted, the technical requirements of this Appendix shall apply.

**1.3. Electric Circuit Diagnostic**

1.3.1. For the purposes of Clause 1.4.3.5. and 1.4.3.6 of this Appendix., the electric circuit and electronic failure diagnostics with regard to OBD stage II shall at a minimum contain the sensor and actuator diagnostics as well as the internal diagnostics of the electronic control units required in Appendix 2.2 of this Chapter.

1.3.2 Non-continuously running electric circuit monitoring diagnostics, i.e. those electric circuits monitoring diagnostics that will run until their tests have passed on a non-continuous basis, and completion of clause 1.4.3.6 of this Appendix for the items included in Appendix 2.2 of this Chapter, shall be part of OBD stage II.

1.3.3 Any malfunctions of supplemental devices to be monitored shall be applicable for OBD stage II in addition to those already identified in the table.

**1.4. Functional OBD Requirements**

1.4.1. Vehicles in the scope of this appendix shall be equipped with an OBD system so designed, constructed and installed in a vehicle as to enable it to identify type of malfunction over the useful life of the vehicle. In achieving this objective, the test agency shall accept that vehicles which have travelled distances in excess of the Type V durability distance in the notification. Vehicle may show some deterioration in OBD system performance such that the OBD emission thresholds, given in the notification, may be exceeded before the OBD system signals a failure to the driver of the vehicle.

1.4.1.1. Access to the OBD system related data required for the inspection, diagnosis, servicing or repair of the vehicle shall be unrestricted and standardised. All OBD relevant diagnostic trouble codes shall be consistent with Clause 3.11. of Appendix 2.1 of this Chapter.

1.4.1.2. At the manufacturer's discretion, to aid technicians in the efficient repair of vehicles, the OBD system may be extended to monitor and report on any other on-board system. Extended diagnostic systems shall not be considered as falling under the scope of approval requirements.

- 1.4.2. The OBD system shall be so designed, constructed and installed in a vehicle as to enable it to comply with the requirements of this appendix during conditions of normal use.
- 1.4.2.1. **Temporary disablement of the OBD system**
- 1.4.2.1.1. A manufacturer may disable the OBD system at ambient engine starting temperatures below  $-7^{\circ}\text{C}$  or at elevations over 2500 metres above sea level, provided it submits data or an engineering evaluation which adequately demonstrate that monitoring would be unreliable in such conditions. It may also request disablement of the OBD system at other ambient engine starting temperatures if it demonstrates to the test agency with data or an engineering evaluation that misdiagnosis would occur under such conditions. It is not necessary to illuminate the malfunction indicator (MI) if the OBD thresholds are exceeded during regeneration, provided no defect is present.
- 1.4.2.1.2. For vehicles designed to accommodate the installation of power take-off units, disablement of affected monitoring systems is permitted provided disablement occurs only when the power take-off unit is active.
- 1.4.2.1.3. The manufacturer may temporarily disable the OBD system in the following conditions:
- (a) For flex-fuel or mono/bi-fuel gas vehicles for one minute after re-fuelling to allow for the recognition of fuel quality and composition by the Powertrain Control Unit(s) (PCU);
  - (b) For bi-fuel vehicles for five seconds after fuel switching to allow for engine parameters to be readjusted;
  - (c) The manufacturer may deviate from these time limits if it can be demonstrated that stabilisation of the fuelling system after re-fuelling or fuel switching takes longer for justified technical reasons. In any case, the OBD system shall be re-enabled as soon as either the fuel quality or composition is recognised or the engine parameters are readjusted.
- 1.4.2.2. Engine misfire in vehicles equipped with positive-ignition engines.
- 1.4.2.2.1. Manufacturers may adopt higher misfire percentage malfunction criteria than those declared to the test agency, under specific engine speed and load conditions where it can be demonstrated to the test agency that the detection of lower levels of misfire would be unreliable. In terms of OBD monitoring, it is that percentage of misfires out of a total number of firing events (as declared by the manufacturer) that would result in emissions exceeding the OBD thresholds set out in the notification, or that percentage that could lead to an exhaust catalyst, or catalysts, overheating, causing irreversible damage;

- 1.4.2.2.2. When a manufacturer can demonstrate to the test agency that the detection of higher levels of misfire percentages is still not feasible, or that misfire cannot be distinguished from other effects (e.g. rough roads, transmission shifts, after engine starting, etc.), the misfire monitoring system may be disabled when such conditions exist.
- 1.4.3. **Description of tests**
- 1.4.3.1. The OBD II system shall indicate the failure of an emission-related component or system when that failure results in emissions exceeding the OBD II emission threshold limits referred to in the notification.
- 1.4.3.2. The OBD II system for vehicles equipped with PI engines shall monitor for:
- 1.4.3.2.1. At a minimum, the electric / electronic circuits required in Appendix 2.2 of this Chapter.
- 1.4.3.2.2. The reduction in the efficiency of the catalytic converter with respect to emissions of hydrocarbons and nitrogen oxides. Manufacturers may monitor the front catalyst alone or in combination with the next catalyst(s) downstream. Each monitored catalyst or catalyst combination shall be considered to be malfunctioning if the emissions exceed the NMHC or NO<sub>x</sub> thresholds provided in the notification.
- 1.4.3.2.3. Engine misfire  
 The presence of engine misfire in the engine operating region bounded by the following lines:  
 maximum design engine speed minus 500 min<sup>-1</sup> ;  
 the positive torque line (i.e. engine load with the transmission in neutral);  
 linear lines joining the following engine operating points: the positive torque line at 3000 min<sup>-1</sup> and a point on the maximum speed line defined in (a) above with the engine's manifold vacuum at 13.3 kPa lower than that at the positive torque line.
- 1.4.3.2.4. Oxygen sensor deterioration  
 This section shall mean that the deterioration of all oxygen sensors fitted and used for monitoring malfunctions of the catalytic converter in accordance with the requirements of this Appendix shall be monitored.
- 1.4.3.2.5. The electronic evaporative emission purge control shall, at a minimum, be monitored for circuit continuity.
- 1.4.3.2.6. For direct injection PI engines, any malfunction that could lead to emissions exceeding the particulate mass (PM) OBD emission thresholds provided in the notification shall be monitored in accordance with the requirements of this Appendix.

- 1.4.3.3. The OBD II system for vehicles equipped with CI engines shall monitor for:
  - 1.4.3.3.1. At a minimum, the electric / electronic circuits required in Appendix 2.2 of this Chapter.
  - 1.4.3.3.2. Reduction in the efficiency of the catalytic converter, where fitted;
  - 1.4.3.3.3. The functionality and integrity of the particulate trap, where fitted.
  - 1.4.3.3.4. The fuel-injection system electronic fuel quantity and timing actuator(s) is/are monitored for circuit continuity and total functional failure.
  - 1.4.3.3.5. Malfunctions and the reduction in efficiency of the EGR system, shall be monitored.
  - 1.4.3.3.6. Malfunctions and the reduction in efficiency of a NO<sub>x</sub> after-treatment system using a reagent and the reagent dosing subsystem shall be monitored.
  - 1.4.3.3.7. Malfunctions and the reduction in efficiency of NO<sub>x</sub> after-treatment not using a reagent shall be monitored.
- 1.4.3.4. If active on the selected fuel, other emission controls system components or systems, or emission-related powertrain components or systems, which are connected to a computer and the failure of which may result in tailpipe emissions exceeding the OBD emission thresholds given in the notification shall be monitored.
- 1.4.3.5. Unless otherwise monitored, any other electronic powertrain component connected to a computer relevant for environmental performance and/or functional safety, including any relevant sensors to enable monitoring functions to be carried out, shall be monitored for electric / electronic circuit failures. In particular, these electronic components shall be continuously monitored for any electric circuit continuity failure, shorted electric circuits, electric range / performance and stuck signal of the control system in accordance with Appendix 2.2 of this Chapter.
- 1.4.3.6. Unless otherwise monitored, any other powertrain component connected to a computer relevant for the environmental performance and/or functional safety, triggering any programmed 'limp-home' operating mode which significantly reduces engine torque, e.g. to safeguard powertrain components. Without prejudice to the Table 2 of Appendix 2.2, the relevant diagnostic trouble code shall be stored.
- 1.4.3.7. Manufacturers may demonstrate to the test agency that certain components or systems need not be monitored if, in the event of their total failure or removal, emissions do not exceed the emission limits given in the notification.

- 1.4.4. A sequence of diagnostic checks shall be initiated at each engine start and completed at least once provided that the correct test conditions are met. The test conditions shall be selected in such a way that they all occur in the course of normal driving as represented by the Type I test. If the failure cannot be reliably detected under the Type I test conditions, the manufacturer may propose supplemental test conditions that do allow robust detection of the failure to be agreed with the test agency.
- 1.4.5. **Activation of the Malfunction Indicator (MI)**
- 1.4.5.1. The OBD system shall incorporate a malfunction indicator readily perceivable to the vehicle operator. The MI shall not be used for any purposes other than to indicate emergency start-up or limp-home routines to the driver. The MI shall be visible in all reasonable lighting conditions. When activated, it shall display a symbol in conformity with ISO 2575:2010, symbol F.01. A vehicle shall not be equipped with more than one general purpose MI used to convey power-train related failures which may affect emissions or limp home mode. Separate specific purpose tell tales (e. g. brake system, fasten seat belt, oil pressure, etc.) are permitted. The use of red colour for a MI is prohibited.
- 1.4.5.2. For strategies requiring more than two preconditioning cycles for MI activation, the manufacturer shall provide data or an engineering evaluation which adequately demonstrate that the monitoring system is equally effective and timely in detecting component deterioration. Strategies requiring on average more than ten driving cycles for MI activation are not accepted. MI shall also activate whenever the powertrain control enters a permanent default mode of operation leading to a significant torque reduction or if the OBD emission thresholds in the notification are exceeded or if the OBD system is unable to fulfil the basic monitoring requirements laid down in clauses 1.4.3.2 or 1.4.3.3 of this Appendix.
- 1.4.5.3. MI shall operate in a distinct warning mode, e.g. a flashing light, during any period in which engine misfire occurs at a level likely to cause catalyst damage, as specified by the manufacturer.
- 1.4.5.4. The MI shall also activate when the vehicle's ignition is in the "key-on" position before engine starting or cranking and deactivate if no malfunction has been detected. For vehicles not equipped with a battery, the MI shall illuminate immediately after engine starting and shall subsequently be deactivated after 5 seconds, if no malfunction has previously been detected.
- 1.4.6. The OBD system shall record diagnostic trouble code(s) indicating the status of the control system for OBD or of the functional safety system leading to an operation mode with significantly reduced torque in comparison to normal operation mode. Separate status codes shall be used to identify correctly functioning control systems and those control systems which need further vehicle operation to be fully evaluated. If

the MI is activated due to deterioration or malfunction or permanent default modes of operation, a diagnostic trouble code shall be stored that identifies the type of malfunction. A diagnostic trouble code shall also be stored in the cases referred to in Clause 1.4.3.5. and 1.4.3.6.

- 1.4.6.1. The distance travelled by the vehicle while the MI is activated shall be available at any moment through the serial port on the standardised diagnostic connector. By means of derogation for vehicles equipped with a mechanically operating odometer that does not allow input to the electronic control unit, including such vehicles equipped with a CVT that does not allow for an accurate input to electronic control unit, "distance travelled" may be replaced with "engine operation time" and shall be made available at any moment through the serial port on the standardised diagnostic connector. Engine operation time in this context means the total accumulated time in which the propulsion unit(s) provide(s) mechanical output (e.g. the crankshaft of a combustion engine or electric motor rotates) after triggering the MI activation during one or more key cycles.
- 1.4.6.2. In the case of vehicles equipped with PI engines, misfiring cylinders need not be uniquely identified if a distinct single or multiple cylinder misfire fault code is stored.
- 1.4.6.3. The MI may be activated at levels of emissions below the OBD II emission thresholds set out in the notification.
- 1.4.6.4. The MI may be activated if a default mode is active without significant reduction of propulsion torque.
- 1.4.7. **Extinguishing the MI**
- 1.4.7.1. If misfire at levels likely to cause catalyst damage (as specified by the manufacturer) is no longer taking place, or if the engine is operated after changes to speed and load conditions where the level of misfire will not cause catalyst damage, the MI may be switched back to the previous state of activation during the first driving cycle on which the misfire level was detected and to the normal activated mode on subsequent driving cycles. If the MI is switched back to the previous state of activation, the corresponding fault codes and stored freeze-frame conditions may be erased.
- 1.4.7.2. For all malfunctions, the MI may be deactivated after three subsequent sequential driving cycles during which the monitoring system responsible for activating the MI ceases to detect the malfunction and if no other malfunction has been identified that would independently activate the MI.
- 1.4.8. **Erasing a diagnostic trouble code**
- 1.4.8.1. The OBD system may erase a diagnostic trouble code and the distance travelled and freeze-frame information if the same fault is not re-registered in at least 40 engine warm-up cycles.

1.4.8.2. Stored faults shall not be erased by disconnection of the on-board computer from the vehicle power supply or by disconnection or failure of the vehicle battery or batteries.

1.5. **Requirements relating to the approval of On-Board Diagnostic Systems**

1.5.1. In addition to common requirements, the test agency shall not accept any deficiency request that does not respect the OBD threshold in the notification.

1.5.2. For OBD II, In the identified order of deficiencies, those relating to clauses 1.4.3.2.2., 1.4.3.2.3. and 1.4.3.2.4 of this Appendix. For PI engines and clauses 1.4.3.3.2., 1.4.3.3.3. and 1.4.3.3.4. of this Appendix for CI engines shall be identified first.



## APPENDIX 2.1 TO CHAPTER 6

### FUNCTIONAL ASPECTS OF ON-BOARD DIAGNOSTIC (OBD) SYSTEMS

#### 1.0 INTRODUCTION

The on-board diagnostic systems fitted on vehicles in the scope of this appendix shall comply with the detailed information and functional requirements and verify if the system is capable of meeting the functional part of the on-board diagnostic requirements.

#### 2.0 ON-BOARD DIAGNOSTIC FUNCTIONAL VERIFICATION TESTING

- 2.1. The on-board diagnostic environmental system performance and the functional OBD capabilities shall be verified and demonstrated to the test agency by performing the type VIII test procedure referred to in Appendix 2.3 of this Chapter.

#### 3.0 DIAGNOSTIC SIGNALS

- 3.1. Upon determination of the first malfunction of any component or system, "freeze-frame" engine conditions present at the time shall be stored in computer memory in accordance with the specifications in Clause 3.10 of this Appendix. Stored engine conditions shall include, but are not limited to, calculated load value, engine speed, fuel trim value(s) (if available), fuel pressure (if available), vehicle speed (if available), coolant temperature (if available), intake manifold pressure (if available), closed- or open-loop operation (if available) and the diagnostic trouble code which caused the data to be stored.

- 3.1.1. The manufacturer shall choose the most appropriate set of conditions facilitating effective and efficient repairs in freeze-frame storage. Only one frame of data is required. Manufacturers may choose to store additional frames provided that at least the required frame can be read by a generic scan tool meeting the specifications of Clauses 3.9 and 3.10 of this Appendix. If the diagnostic trouble code causing the conditions to be stored is erased in accordance with Clause 1.4.8. of Appendix 2 of Chapter 6, the stored engine conditions may also be erased.

- 3.1.2. The calculated load value shall be calculated as follows:

Equation 1:

$$CLV = \frac{\text{Current\_airflow}}{\text{Peak\_airflow(at\_sea\_level)}} \cdot \frac{\text{Atmospheric\_pressure\_ (at\_sea\_level)}}{\text{Barometric\_pressure}}$$

- 3.1.3. Alternatively, the manufacturer may choose another appropriate load variable of the propulsion unit (such as throttle position, intake manifold pressure, etc.) and shall demonstrate that the alternative load variable correlates well with calculated load variable set out in Clause 3.1.2 of this Appendix. [And is in accordance with the specifications in Clause 3.10. of this Appendix].

- 3.1.4. If a subsequent fuel system or misfire malfunctions occur any previously stored freeze-frame conditions shall be replaced by the fuel system or misfire conditions (whichever occurs first).
- 3.2. If available, the following signals in accordance with the specifications in Clause 3.10. of this Appendix, in addition to the required freeze-frame information, shall be made available on demand through the serial port on the standardised diagnostic connector, if the information is available to the on-board computer or can be determined using information available to the on-board computer: number of stored diagnostic trouble codes, engine coolant temperature, fuel control system status (closed-loop, open-loop, other), fuel trim, ignition timing advance, intake air temperature, manifold air pressure, air flow rate, engine speed, throttle position sensor output value, secondary air status (upstream, downstream or atmosphere), calculated load value, vehicle speed, the activated default mode(s) and fuel pressure.
- The signals shall be provided in standard units based on the specifications in Clause 3.10. of this Appendix Actual signals shall be clearly identified separately from default value or limp-home signals.
- 3.3. For all control systems for which specific on-board evaluation tests are conducted as listed in Table 2 of Appendix 2.2 of this Chapter except, if applicable, misfire detection, fuel system monitoring and comprehensive component monitoring, the results of the most recent test performed by the vehicle and the limits to which the system is compared, shall be made available through the serial data port on the standardised diagnostic connector according to the specifications in Clause 3.8 of this Appendix. For the monitored components and systems excepted above, a pass/fail indication for the most recent test results shall be available through the standardised diagnostic connector.
- 3.4. The OBD requirements to which the vehicle is certified and the major control systems monitored by the OBD system in accordance with the specifications in Clause 3.10 of this Appendix. shall be made available through the serial data port on the standardised diagnostic data link connector according to the specifications in Clause 3.8 of this Appendix.
- 3.5. The software identification (Calibration Identification number) and calibration verification numbers shall be made available through the serial port on the standardized diagnostic data link connector. Both numbers shall be provided in a standardized format in accordance with the specifications in paragraph 3.10. of this Appendix.
- 3.6. The diagnostic system is not required to evaluate components during malfunction if such evaluation would result in a risk to safety or component failure.

- 3.7. The diagnostic system shall provide for standardised and unrestricted access to OBD and conform to the following ISO standards or SAE specification:
- 3.8. One of the following standards with the restrictions described shall be used as the on-board to off-board communications link:
- ISO 9141-2:1994/Amd 1:1996: "Road Vehicles — Diagnostic Systems — Part 2: CARB requirements for interchange of digital information";
- SAE J1850: March 1998 "Class B Data Communication Network Interface. Emission related messages shall use the cyclic redundancy check and the three-byte header and not use inter byte separation or checksums";
- ISO 14229-3:2012: "Road vehicles — Unified Diagnostic Services (UDS) — Part 3: Unified diagnostic services on CAN implementation";
- ISO 14229-4:2012: "Road vehicles — Unified diagnostic services (UDS) — Part 4: Unified diagnostic services on FlexRay implementation";
- ISO 14230-4:2000: "Road Vehicles — Keyword protocol 2000 for diagnostic systems — Part 4: Requirements for emission-related systems";
- ISO 15765-4:2011: "Road vehicles — Diagnostics on Controller Area Network (CAN) — Part 4: Requirements for emissions-related systems", dated 1 November 2001;
- ISO 22901-2:2011: "Road vehicles — Open diagnostic data exchange (ODX) — Part 2: Emissions-related diagnostic data".
- 3.9. Test equipment and diagnostic tools needed to communicate with OBD systems shall meet or exceed the functional specification in ISO 15031-4:2005: "Road vehicles — Communication between vehicle and external test equipment for emissions-related diagnostics — Part 4: External test equipment".
- 3.10. Basic diagnostic data (as specified in Clause 3 of this Appendix.) and bi-directional control information shall be provided using the format and units described in ISO 15031-5:2011 "Road vehicles — Communication between vehicle and external test equipment for emissions-related diagnostics — Part 5: Emissions-related diagnostic services" and shall be available using a diagnostic tool meeting the requirements of ISO 15031-4:2005.
- 3.10.1. The vehicle manufacturer shall provide the test agency with details of any diagnostic data, e.g. PIDs, OBD monitor IDs, Test IDs not specified in ISO 15031-5:2011 but relating to this Appendix.
- 3.11. When a fault is registered, the manufacturer shall identify the fault using an appropriate diagnostic trouble code consistent with those in Section 6.3. of ISO 15031-6:2010 "Road vehicles — Communication

between vehicle and external test equipment for emissions-related diagnostics — Part 6: Diagnostic trouble code definitions" relating to "emission related system diagnostic trouble codes". If this is not possible, the manufacturer may use the diagnostic trouble codes in Sections 5.3. and 5.6. of ISO DIS 15031-6:2010. Alternatively, diagnostic trouble codes may be compiled and reported according to ISO 14229:2006. The diagnostic trouble codes shall be fully accessible by standardised diagnostic equipment complying with Clause 3.9 of this Appendix.

- 3.11.1. The vehicle manufacturer shall provide to a national standardisation body the details of any emission-related diagnostic data, e.g. PIDs, OBD monitor IDs, Test IDs not specified in ISO 15031-5:2011 or ISO14229:2006, but relating to this Appendix.
- 3.12. The connection interface between the vehicle and the diagnostic tester shall be standardised and meet all the requirements of ISO [DIS] 19689:2016 "Motorcycles and Mopeds — Communication between vehicle and external equipment for diagnostics — Diagnostic connector and related electrical circuits, specification and use" or ISO 15031-3:2004 "Road vehicles — Communication between vehicle and external test equipment for emissions-related diagnostics — Part 3: Diagnostic connector and related electric circuits: specification and use". The preferred installation position is under the seating position. Any other position of the diagnostic connector shall be subject to the test agency's agreement and be readily accessible by service personnel but protected from tampering by non-qualified personnel. The position of the connection interface shall be clearly indicated in the user manual.
- 3.13. Until a standardised connection interface for L-category vehicles has been adopted and published at ISO or CEN level and the reference of that technical standard is included in this Part, an alternative connection interface may be installed at the request of the vehicle manufacturer. Where such an alternative connection interface is installed, the vehicle manufacturer shall make available to test equipment manufacturers the details of the vehicle connector pin configuration free of charge. The vehicle manufacturer shall provide an adapter enabling connection to a generic scan tool. Such an adapter shall be of suitable quality for professional workshop use. It shall be provided upon request to all independent operators in a non-discriminating manner. Manufacturers may charge a reasonable and proportionate price for this adapter, taking into account the additional costs caused for the customer by this choice of the manufacturer. The connection interface and the adapter may not include any specific design elements which would require validation or certification before use, or which would restrict the exchange of vehicle data when using a generic scan tool.

#### **4.0 IN-USE PERFORMANCE [FOR OBD II]**

##### **4.1. General requirements**

- 4.1.1. Each monitor of the OBD system shall be executed at least once per driving cycle in which the monitoring conditions in clause 1.4.2. of this

Appendix 2.1 are met. Manufacturers shall not use the calculated ratio (or any element thereof) or any other indication of monitor frequency as a monitoring condition for any monitor.

- 4.1.2. The in-use performance ratio ('IUPR') of a specific monitor M of the OBD systems and in-use performance of pollution control devices shall be:

$$\text{IUPRM} = \text{Numerator M} / \text{Denominator M}$$

- 4.1.3. Comparison of Numerator and Denominator gives an indication of how often a specific monitor is operating relative to vehicle operation. To ensure all manufacturers are tracking IUPRM in the same manner, detailed requirements are given for defining and incrementing these counters.

- 4.1.4. If, according to the requirements of this Appendix, the vehicle is equipped with a specific monitor M, IUPRM shall be greater or equal 0.1 for all monitors M.

- 4.1.5. The requirements of this point are deemed to be met for a particular monitor M, if for all vehicles of a particular vehicle and propulsion family manufactured in a particular calendar year the following statistical conditions hold:

- (a) The average IUPRM is equal or above the minimum value applicable to the monitor;
- (b) More than 50 % of all vehicles have an IUPRM equal or above the minimum value applicable to the monitor.

- 4.1.6. The manufacturer shall demonstrate to the test agency that these statistical conditions are satisfied for vehicles manufactured in a given calendar year for all monitors required to be reported by the OBD system according to clause 4.6 of this Appendix not later than 18 months after the end of a calendar year. For this purpose, statistical tests shall be used which implement recognised statistical principles and confidence levels.

- 4.1.7. For demonstration purposes of this clause, the manufacturer may group vehicles within a vehicle and propulsion family by any successive non-overlapping 12-month manufacturing periods instead of calendar years. For the entire test sample of vehicles, the manufacturer shall report to the test agency all of the in-use performance data to be reported by the OBD system in accordance with clause 4.6 of this Appendix. Upon request, the test agency which grants the approval shall make these data and the results of the statistical evaluation available to other test agencies.

- 4.1.8. The test agency may pursue further tests on vehicles or collect appropriate data recorded by vehicles to verify compliance with the requirements of this Appendix.

4.1.9. In-use performance-related data to be stored and reported by a vehicle's OBD system shall be made readily available by the manufacturer to national authorities and independent operators without any encryption.

4.2. **Numerator M**

4.2.1. The numerator of a specific monitor is a counter measuring the number of times a vehicle has been operated in such a way that all monitoring conditions necessary for the specific monitor to detect a malfunction in order to warn the driver, as they have been implemented by the manufacturer, have been encountered. The numerator shall not be incremented more than once per driving cycle, unless there is reasoned technical justification.

4.3. **Denominator M**

4.3.1. The purpose of the denominator is to provide a counter indicating the number of vehicle driving events, taking into account special conditions for a specific monitor. The denominator shall be incremented at least once per driving cycle, if during this driving cycle such conditions are met and the general denominator is incremented as specified in clause 4.5 of this Appendix, unless the denominator is disabled according to clause 4.7 of this Appendix.

4.3.2. In addition to the requirements of clause 4.3.1 of this Appendix:

Secondary air system monitor denominator(s) shall be incremented if the commanded 'on' operation of the secondary air system occurs for a time greater than or equal to 10 seconds. For purposes of determining this commanded 'on' time, the OBD system shall not include time during intrusive operation of the secondary air system solely for the purposes of monitoring.

Denominators of monitors of systems only active during cold start shall be incremented if the component or strategy is commanded 'on' for a time greater than or equal to 10 seconds.

The denominator(s) for monitors of Variable Valve Timing (VVT) and/or control systems shall be incremented if the component is commanded to function (e.g. commanded 'on', 'open', 'closed', 'locked', etc.) on two or more occasions during the driving cycle or for a time greater than or equal to 10 seconds, whichever occurs first.

For the following monitors, the denominator(s) shall be incremented by one if, in addition to meeting the requirements of this clause on at least one driving cycle, at least 800 cumulative kilometers of vehicle operation have been experienced since the last time the denominator was incremented:

- (i) Diesel oxidation catalyst;
- (ii) Diesel particulate filter.

4.3.3. For hybrid vehicles, vehicles that employ alternative engine start hardware or strategies (e.g. integrated starter and generators), or alternative fuel vehicles (e.g. dedicated, bi-fuel, or dual-fuel applications), the manufacturer may request the approval of the test

agency to use alternative criteria to those set out in this point for incrementing the denominator. In general, the test agency shall not approve alternative criteria for vehicles that employ engine shut off only at or near idle/vehicle stop conditions. The test agency's approval of the alternative criteria shall be based on their equivalence to determine the amount of vehicle operation relative to the measure of conventional vehicle operation in accordance with the criteria in this point.

**4.4. Ignition cycle counter**

4.4.1. The ignition cycle counter indicates the number of ignition cycles a vehicle has experienced. The ignition cycle counter may not be incremented more than once per driving cycle.

**4.5. General denominator**

4.5.1. The general denominator is a counter measuring the number of times a vehicle has been operated. It shall be incremented within 10 seconds, if and only if, the following criteria are satisfied on a single driving cycle:

Cumulative time since engine start is greater than or equal to 600 seconds at an elevation of less than 2440 m above sea level and an ambient temperature of ( $-7\text{ }^{\circ}\text{C}$ ) or more;

Cumulative vehicle operation at or above 25 km/h occurs for 300 seconds or more at an elevation of less than 2440 m above sea level and an ambient temperature of ( $-7\text{ }^{\circ}\text{C}$ ) or more;

Continuous vehicle operation at idle (i.e. accelerator pedal released by driver and vehicle speed of 1.6 km/h or less) for 30 seconds or more at an elevation of less than 2440 m above sea level and an ambient temperature of ( $-7\text{ }^{\circ}\text{C}$ ) or more.

**4.6. Reporting and increasing counters**

4.6.1. The OBD system shall report in accordance with the ISO 15031-5:2011 specifications the ignition cycle counter and general denominator as well as separate numerators and denominators for the following monitors, if their presence on the vehicle is required by this Appendix:

- (a) Catalysts (each bank to be reported separately);
- (b) Oxygen/exhaust gas sensors, including secondary oxygen sensors (each sensor to be reported separately);
- (c) Evaporative system;
- (d) Exhaust Gas Recirculation (EGR) system;
- (e) Variable Valve Train (VVT) system;
- (f) Secondary air system;

- (g) Particulate filter;
  - (h) NO<sub>x</sub> after-treatment system (e.g. NO<sub>x</sub> absorber, NO<sub>x</sub> reagent/catalyst system);
  - (i) Boost pressure control system.
- 4.6.2. For specific components or systems that have multiple monitors which have to be reported under this point (e.g. oxygen sensor bank 1 may have multiple monitors for sensor response or other sensor characteristics), the OBD system shall separately track numerators and denominators for each of the specific monitors and report only the corresponding numerator and denominator for the specific monitor that has the lowest numerical ratio. If two or more specific monitors have identical ratios, the corresponding numerator and denominator for the specific monitor that has the highest denominator shall be reported for the specific component.
- 4.6.3. All counters, when incremented, shall be incremented by an integer of one.
- 4.6.4. The minimum value of each counter is 0; the maximum value shall not be less than 65535, notwithstanding any other requirements regarding standardised storage and reporting of the OBD system.
- 4.6.5. If either the numerator or denominator for a specific monitor reaches its maximum value, both counters for that specific monitor shall be divided by two before being incremented again in accordance with clauses 4.2 and 4.3 of this Appendix. If the ignition cycle counter or the general denominator reaches its maximum value, the respective counter shall change to zero at its next increment in accordance with clauses 4.4 and 4.5 of this Appendix respectively.
- 4.6.6. Each counter shall be reset to zero only when a non-volatile memory reset occurs (e.g. reprogramming event, etc.) or, if the numbers are stored in keep-alive memory (KAM), when KAM is lost due to an interruption in electrical power to the control module (e.g. battery disconnect, etc.).
- 4.6.7. The manufacturer shall take measures to ensure that the values of numerator and denominator cannot be reset or modified, except in cases provided for explicitly in this point.



#### 4.7. **Disablement of Numerators and Denominators and of the General Denominator**

- 4.7.1. Within 10 seconds of detection of a malfunction which disables a monitor required to meet the monitoring conditions of this Appendix (i.e. a pending or confirmed code is stored), the OBD system shall disable further incrementing of the corresponding numerator and denominator for each monitor that is disabled. When the malfunction is no longer detected (i.e. the pending code is erased through self-clearing or a scan tool command), incrementing of all corresponding numerators and denominators shall resume within 10 seconds.
- 4.7.2. Within 10 seconds of the start of a power take-off operation (PTO) that disables a monitor required to meet the monitoring conditions of this Appendix, the OBD system shall disable further incrementing of the corresponding numerator and denominator for each monitor that is disabled. When the PTO operation ends, incrementing of all corresponding numerators and denominators shall resume within 10 seconds.
- 4.7.3. The OBD system shall disable further incrementing of the numerator and denominator of a specific monitor within 10 seconds, if a malfunction of any component used to determine the criteria within the definition of the specific monitor's denominator (i.e. vehicle speed, ambient temperature, elevation, idle operation, engine cold start or time of operation) has been detected and the corresponding pending fault code has been stored. Incrementing of the numerator and denominator shall resume within 10 seconds when the malfunction is no longer present (e.g. pending code erased through self-clearing or by a scan tool command).
- 4.7.4. The OBD system shall disable further incrementing of the general denominator within 10 seconds if a malfunction has been detected of any component used to determine whether the criteria in clause 1.4.5 of this Appendix are satisfied (i.e. vehicle speed, ambient temperature, elevation, idle operation or time of operation) and the corresponding pending fault code has been stored. The general denominator may not be disabled from incrementing for any other condition. Incrementing of the general denominator shall resume within 10 seconds when the malfunction is no longer present (e.g. pending code erased through self-clearing or by a scan tool command).

### 5.0 **ACCESS TO OBD INFORMATION**

- 5.1. Applications for approval or its amendments shall be accompanied by the repair information concerning the vehicle OBD system. This information shall enable manufacturers of replacement or retrofit components to make the parts they manufacture compatible with the vehicle OBD system, with a view to fault-free operation assuring the vehicle user against malfunctions. Similarly, such repair information shall enable the manufacturers of diagnostic tools and test equipment to make tools and equipment that provide for the effective and accurate diagnosis of vehicle control systems.

- 5.2. Upon request, the vehicle manufacturer shall make the repair information on the OBD system available to any interested components, diagnostic tools or test equipment manufacturer on a non-discriminatory basis:
  - 5.2.1. A description of the type and number of preconditioning cycles used for the original approval of the vehicle;
  - 5.2.2. A description of the type of the OBD demonstration cycle used for the original approval of the vehicle for the component monitored by the OBD system;
  - 5.2.3. A comprehensive document describing all sensed components with the strategy for fault detection and MI activation (fixed number of driving cycles or statistical method), including a list of relevant secondary sensed parameters for each component monitored by the OBD system and a list of all OBD output codes and format used (with an explanation of each) associated with individual emission related powertrain components and individual non-emission related components, where monitoring of the component is used to determine MI activation.
  - 5.2.4. This information may be provided in the form of a table, as follows:

**Table 1:  
Template OBD information list**

<i>Component</i>	<i>Diagnostic trouble code</i>	<i>Monitoring strategy</i>	<i>Fault detection criteria</i>	<i>MI activation criteria</i>	<i>Secondary parameters</i>	<i>Preconditioning</i>	<i>Demonstration test</i>	<i>Default mode</i>
Catalyst	P0420	Oxygen sensor 1 and 2 signals	Difference between sensor 1 and sensor 2 signals	3rd cycle	Engine speed, engine load, A/F mode, catalyst temperature	Two type I cycles	Type I	None

- 5.2.5. If the test agency receives a request from any interested components, diagnostic tools or test equipment manufacturer for information on the OBD system of a vehicle that has been type approved by that test agency

That test agency shall, within 30 days, ask the manufacturer of the vehicle in question to make available the information required in Clauses 5.1. and 5.2 of this Appendix;

The vehicle manufacturer shall submit this information to that test agency within two months of the request;

That test agency shall transmit this information and shall attach this information to the vehicle approval information.

- 5.2.6. Information can be requested only for replacement or service components that are subject to approval or for components that form part of a system subject to approval.

- 5.2.7. The request for repair information shall identify the exact specification of the vehicle model for which the information is required. It shall confirm that the information is required for the development of replacement or retrofit parts or components or diagnostic tools or test equipment.

- 5.2.8. Access to vehicle security features used by authorised dealers and repair shops shall be made available to independent operators under protection of security technology according to the following requirements:

- (a) Data shall be exchanged ensuring confidentiality, integrity and protection against replay;

The standard [https//ssl-tls](https://ssl-tls) (RFC4346) shall be used;

Security certificates in accordance with ISO 20828 shall be used for mutual authentication of independent operators and manufacturers;

The independent operator's private key shall be protected by secure hardware.

- 5.2.8.1. The independent operator shall be approved and authorized for this purpose on the basis of documents demonstrating that they pursue a legitimate business activity and have not been convicted of relevant criminal activity.

**APPENDIX 2.2 TO CHAPTER 6  
MINIMUM MONITORING REQUIREMENTS FOR AN ON BOARD  
DIAGNOSTIC (OBD) SYSTEM STAGE II**

**1.0 INTRODUCTION**

The following minimum monitoring requirements shall apply for OBD systems complying with the requirements of OBD stage II regarding electric circuit diagnostics.

**2.0 MONITORING REQUIREMENTS**

2.1. If fitted, the following listed sensors and actuators shall be monitored for electric circuit malfunctions.

<b>Table 1 : Scope of OBD II</b>	
<b>Items</b>	<b>Scope of OBD II</b>
Table 2 of this Appendix	yes
Any other sensor or actuator circuit declared by the manufacturer	yes
OBD fail thresholds	yes

2.2. At a minimum the monitored devices with mandatory circuit diagnostics shall be the following and may also cause the emissions to exceed the designated OBD II emission thresholds laid down in the notification and/or lead to activation of a default mode that results in a significant reduction of propulsion torque.

**Table 2  
Overview of devices (if fitted) to be monitored in OBD stage II**

<b>No.</b>	<b>Device circuits</b>		<b>Circuit continuity</b>			<b>Circuit rationality</b>			<b>Comment No.</b>	
			<i>Circuit High</i>	<i>Circuit Low</i>	<i>Open Circuit</i>	<i>Out of Range</i>	<i>Performance / Plausibility</i>	<i>Signal stuck</i>		<i>Device not operational / Device not present</i>
		<i>Level, refer to 2.3.</i>								
1	Control module (ECU / PCU) internal error	3						II	(1)	
<b>Sensor (input to control units)</b>										

1	Accelerator (pedal / handle) position sensor	1 & 3	II	II	II	(II)	(II)	(II)		( <sup>2</sup> )
2	Barometric pressure sensor	1	II	II	II		II			
3	Camshaft position sensor	3	II	II	II				II	( <sup>3</sup> )
4	Crankshaft position sensor	3							II	
5	Engine coolant temperature sensor	1	II	II	II	(II)	(II)	(II)		( <sup>4</sup> )
6	Exhaust control valve angle sensor	1	II	II	II	(II)	(II)	(II)		( <sup>4</sup> )
7	Exhaust gas recirculation sensor	1 & 3	II	II	II	(II)	(II)	(II)		( <sup>4</sup> )
8	Fuel rail pressure sensor	1	II	II	II	(II)	(II)	(II)		( <sup>4</sup> )
9	Fuel rail temperature sensor	1	II	II	II	(II)	(II)	(II)		( <sup>4</sup> )
10	Gear shift position sensor (potentiometer type)	1	II	II	II	(II)	(II)	(II)		( <sup>4</sup> )
11	Gear shift position sensor (switch type)	3					(II)		II	
12	Intake air temperature sensor	1	II	II	II	(II)	(II)	(II)		( <sup>4</sup> )
13	Knock sensor (Non- resonance type)	3					(II)		II	
14	Knock sensor (Resonance type)	3					II			
15	Manifold absolute pressure sensor	1	II	II	II	(II)	(II)	(II)		( <sup>4</sup> )
16	Mass air flow sensor	1	II	II	II	(II)	(II)	(II)		( <sup>4</sup> )
17	Engine oil temperature sensor	1	II	II	II	(II)	(II)	(II)		( <sup>4</sup> )
18	O2 exhaust sensor (binary / linear) signals	1	II	II	II	(II)	(II)	(II)		( <sup>4</sup> )
19	Fuel (high) pressure sensor	1	II	II	II	(II)	(II)	(II)		( <sup>4</sup> )
20	Fuel storage temperature sensor	1	II	II	II	(II)	(II)	(II)		( <sup>4</sup> )
21	Throttle position sensor	1&3	II	II	II	(II)	(II)	(II)		( <sup>2</sup> )

22	Vehicle speed sensor	3					(II)		II	( <sup>5</sup> )
23	Wheel speed sensor	3					(II)		II	( <sup>5</sup> )
<b>Actuators (output control units)</b>										
1	Evaporative emission system purge control valve	2	(II)	II	(II)					
2	Exhaust control valve actuator (motor driven)	3					II		II	
3	Exhaust gas recirculation control	3					II			
4	Fuel injector	2		II					(II)	( <sup>6</sup> )
5	Idle air control system	1	II	II	II		II		(II)	( <sup>6</sup> )
6	Ignition coil primary control circuits	2		II					(II)	( <sup>6</sup> )
7	O <sub>2</sub> exhaust sensor heater	1	II	II	II		II		(II)	( <sup>6</sup> )
8	Secondary air injection system	2	(II)	II	(II)				(II)	( <sup>6</sup> )
9	Throttle by wire actuator	3		II					(II)	( <sup>6</sup> )
<p>(<sup>1</sup>) Only in case of an activated limp-home mode (default mode leading to a significantly reduced propulsion torque) or if a throttle by wire system is fitted.</p> <p>(<sup>2</sup>) If there is only one APS or TPS fitted, APS or TPS circuit rationality monitoring is not mandatory.</p> <p>(<sup>3</sup>) OBD stage II : level 1 &amp; 3</p> <p>(<sup>4</sup>) OBD stage II: two out of three of the circuit rationality malfunctions marked with 'II' shall be monitored in addition to circuit continuity monitoring.</p> <p>(<sup>5</sup>) Only if used as input to ECU / PCU with relevance to environmental performance or when the OBD system fault triggers a limp-home mode.</p> <p>(<sup>6</sup>) Derogation allowed if manufacturer requests, level 3 instead, actuator signal present only without indication of symptom.</p>										

- 2.2. If there are more of the same device types fitted on the vehicle listed in Table 2 of this Appendix, those devices shall be separately monitored and reported in case of malfunctions. If a malfunction is marked with "II" in Table 2 of this appendix it shall mean that monitoring is mandatory for OBD stage II.
- 2.3. Sensors and actuators shall be associated with a specific diagnostic level that defines which type of diagnostic monitoring shall be performed as follows:

- 2.3.1. **Level 1:** sensor/actuator of which at least two circuit continuity symptoms can be detected and reported (i.e. short circuit to ground, short circuit to power and open circuit).
- 2.3.2. **Level 2:** sensor/actuator of which at least one circuit continuity symptom can be detected and reported (i.e. short circuit to ground, short circuit to power and open circuit).
- 2.3.3. **Level 3:** sensor/actuator of which at least one symptom can be detected, but not reported separately.

2.4. Two out of three symptoms in circuit continuity as well as in circuit rationality monitoring diagnostic may be combined, e.g. circuit high or open and low circuit / high and low or open circuit / signal out of range or circuit performance and signal stuck.

2.5. **Exemptions regarding detection**

Exemption from detecting certain electric circuit monitoring symptoms may be granted if the manufacturer can demonstrate to the satisfaction of the test agency

- 2.5.1 a listed malfunction will not cause emissions to exceed the designated OBD emission threshold set out in the notification; or
- 2.5.2 a listed malfunction will not cause a significant torque loss; or
- 2.5.3 the only feasible monitoring strategy would negatively affect vehicle safety or driveability in a significant way.

2.6 **Exemption regarding OBD verification tests (test Type VIII)**

At the request of the manufacturer and based on a technical justification to the satisfaction of the test agency, certain OBD monitors listed in Table 2 of this Appendix may be exempted from test Type VIII verification tests referred to in Appendix 2.3 of this chapter under the condition that the manufacturer can demonstrate to test agency that:

- 2.6.1. The malfunction indicator fitted to the vehicle is activated when the malfunction listed in Table 2 of this Appendix occurs:
  - 2.6.1.1. During the same key cycle and;
  - 2.6.1.2. Immediately after expiration of a limited time delay (300 s or less) in that same key cycle; or
- 2.6.2. Monitoring of some of the items listed in Table 2 of Appendix 2.2 of this Chapter is physically not possible and a deficiency has been granted for this incomplete monitor. The comprehensive, technical justification why such an OBD monitor cannot run shall be added to the information folder.

**APPENDIX 2.3 TO CHAPTER 6**  
**TEST TYPE VIII, ON-BOARD DIAGNOSTIC ENVIRONMENTAL**  
**VERIFICATION TEST**

**1.0 INTRODUCTION**

- 1.1. This Appendix describes the procedure for Type VIII testing, On-Board Diagnostics (OBD) environmental verification testing, which is required for the approval of a vehicle complying with OBD stage II requirements. The procedure describes methods for checking the function of the OBD system on the vehicle by simulating failure of components in the powertrain management system and emission-control system.
- 1.2. The manufacturer shall make available the defective components or electrical devices to be used to simulate failures. When measured over the appropriate test Type I cycle, such defective components or devices shall not cause the vehicle emissions to exceed by more than 20 percent the OBD thresholds set out in the notification. For electric failures (short/open circuit) the emissions may exceed the OBD emission thresholds by more than 20 per cent.
- 1.3. When the vehicle is tested with the defective component or device fitted, the OBD system shall be approved if the malfunction indicator is activated. The system shall also be approved if the indicator is activated below the OBD thresholds.

**2.0 OBD STAGE II**

- 2.1 The test procedures of this Appendix shall be used by the manufacturer to demonstrate compliance with OBD II requirements.

**3.0 DESCRIPTION OF TESTS**

- 3.1. The OBD system shall indicate the failure of any of the devices in accordance with Appendix 2.2 of this Chapter.
- 3.2. The test Type I data in the template for a test report including the used dynamometer settings and applicable emission laboratory test cycle shall be provided for reference.
- 3.3. **The list with PCU / ECU malfunctions shall be provided :**
  - 3.3.1. For each malfunction that leads to the OBD emission thresholds set out in the notification in both non-defaulted and defaulted driving mode being exceeded, the emission laboratory test results shall be reported in those additional columns in the format of the information document referred to in Appendix 2.4 of this Chapter;
  - 3.3.2. For short descriptions of the test methods used to simulate the malfunctions, as referred to in Clause 4 of this Appendix.



## **4.0 OBD ENVIRONMENTAL TEST PROCEDURE**

### **4.1. The testing of OBD systems consists of the following phases:**

- 4.1.1. Simulation of malfunction of a component of the powertrain management or emission-control system;
- 4.1.2. Preconditioning of the vehicle (in addition to the preconditioning specified in Chapter 2) with a simulated malfunction. The simulated malfunction will lead to the OBD thresholds being exceeded.
- 4.1.3. Driving the vehicle with a simulated malfunction over the applicable Type I test cycle and tailpipe emissions of the vehicle to be measured;
- 4.1.4. Determining whether the OBD system reacts to the simulated malfunction and alerts the vehicle driver to it in an appropriate manner.
- 4.2. Alternatively, at the request of the manufacturer, malfunction of one or more components may be electronically simulated in accordance with the requirements laid down in Clause 8 of this Appendix.
- 4.3. Manufacturers may request that monitoring take place outside the Type I test cycle if it can be demonstrated to the test agency that the monitoring conditions of the Type I test cycle would be restrictive when the vehicle is used in service.
- 4.4. For all demonstration testing, the Malfunction Indicator (MI) shall be activated before the end of the test cycle.

## **5.0 TEST VEHICLE AND FUEL**

### **5.1. Test vehicle**

The aged, test parent vehicle or a new vehicle fitted with defective components or electrical devices shall meet the propulsion unit family requirements laid down in Chapter 7.

- 5.2. The manufacturer shall set the system or component for which detection is to be demonstrated at or beyond the criteria limit prior to operating the vehicle over the test cycle appropriate for the classification of the vehicle. To determine correct functionality of the diagnostic system, the test vehicle shall then be operated over the appropriate Type I test cycle at the discretion of the manufacturer.

### **5.3. Test fuel**

The reference fuel to test the vehicle shall be as specified in the notification and be of the same specification as the reference fuel used to conduct the Type I tailpipe emissions after cold start. The selected fuel type shall not be changed during any of the test phases.

**6.0 TEST TEMPERATURE AND PRESSURE**

6.1. The test temperature and ambient pressure shall meet the requirements of the specified Type I test.

**7.0 TEST EQUIPMENT**

**7.1. CHASSIS DYNAMOMETER**

The chassis dynamometer shall meet the requirements of Chapter 2.

**8.0 OBD ENVIRONMENTAL VERIFICATION TEST PROCEDURES**

8.1. The operating test cycle on the chassis dynamometer shall meet the test Type I requirements.

8.1.1. The Type I test need not be performed for the demonstration of electrical failures (short/open circuit). The manufacturer may demonstrate these failure modes using driving conditions in which the component is used and the monitoring conditions are encountered. Those conditions shall be documented in the Type approval documentation.

**8.2. Vehicle Preconditioning**

8.2.1. According to the propulsion type and after introduction of one of the failure modes referred to in Clause 8.3. of this Appendix, the vehicle shall be preconditioned by driving at least two consecutive appropriate Type I tests. For vehicles equipped with a compression ignition engine, additional preconditioning of two appropriate Type I test cycles is permitted.

8.2.2. At the request of the manufacturer, alternative preconditioning methods may be used.

8.2.3. The use of additional preconditioning cycles or alternative preconditioning methods shall be documented in the Type approval documentation.

**8.3. Failure modes to be tested**

8.3.1. For vehicles equipped with a Positive Ignition (PI) engine:

8.3.1.1. Replacement of the catalytic converter type with a deteriorated or defective catalytic converter or electronic simulation of such a failure;

8.3.1.2. Engine misfire conditions in line with those for misfire monitoring;

8.3.1.3. Replacement of the oxygen sensor with a deteriorated or defective sensor or electronic simulation of such a failure;

- 8.3.1.4. Electrical disconnection of any other component connected to a powertrain control unit / engine control unit (if active on the selected fuel type) in the scope of Appendix 2.2 of this Chapter;
- 8.3.1.5. Electrical disconnection of the electronic evaporative purge control device (if equipped and if active on the selected fuel type). For this specific failure mode, the Type I test need not be performed.
- 8.3.2. For vehicles equipped with a Compression Ignition (CI) engine:
  - 8.3.2.1. Replacement of the catalytic converter type, where fitted, with a deteriorated or defective catalytic converter or electronic simulation of such a failure;
  - 8.3.2.2. Total removal of the particulate filter, where fitted, or, where sensors are an integral part of the filter, a defective filter assembly;
  - 8.3.2.3. Electrical disconnection of any electronic fuel quantity and timing actuator in the fuelling system;
  - 8.3.2.4. Electrical disconnection of any other emission-related component connected to control unit of the powertrain, the propulsion units or the drive train and electrical disconnection or shorted circuit of any other relevant component connected to control computer of the powertrain that triggers a limp-home mode;
  - 8.3.2.5. In meeting the requirements of points 8.3.2.3. and 8.3.2.4. and with the agreement of the test agency, the manufacturer shall take appropriate steps to demonstrate that the OBD system will indicate a fault when disconnection occurs;
- 8.3.3. The manufacturer shall demonstrate that malfunctions of the EGR flow and cooler, where fitted, are detected by the OBD system during its approval test.
- 8.3.4. Any powertrain malfunction that triggers any operating mode which significantly reduces engine torque (i.e. by 10 % or more in normal operation) shall be detected and reported by the powertrain / engine control system.

**8.4. OBD system environmental verification tests**

**8.4.1. Vehicles fitted with Positive Ignition (PI) engines:**

- 8.4.1.1. After vehicle preconditioning in accordance with Clause 8.2. of this Appendix, the test vehicle is driven over the appropriate Type I test.

The malfunction indicator shall activate before the end of this test under any of the conditions given in points 8.4.1.2. to 8.4.1.6. The MI may also be activated during preconditioning. The test agency may substitute those conditions with others in accordance with point 8.4.1.6. However, the total number of failures simulated shall not exceed four for the purpose of Type-approval.

For bi-fuelled gas vehicles, both fuel types shall be used within the maximum of four simulated failures at the discretion of the test agency.

- 8.4.1.2. Replacement of a catalytic converter type with a deteriorated or defective catalytic converter or electronic simulation of a deteriorated or defective catalytic converter that results in emissions exceeding the THC OBD threshold, or if applicable the NMHC OBD threshold, in the notification;
- 8.4.1.3 An induced misfire condition in line with those for misfire monitoring that results in emissions exceeding any of the OBD thresholds given in the notification;
- 8.4.1.4 Replacement of an oxygen sensor with a deteriorated or defective oxygen sensor or electronic simulation of a deteriorated or defective oxygen sensor that results in emissions exceeding any of OBD thresholds in the notification;
- 8.4.1.5 Electrical disconnection of the electronic evaporative purge control device (if equipped and if active on the selected fuel type);
- 8.4.1.6. Electrical disconnection of the electronic evaporative purge control device (if equipped and if active on the selected fuel type);

Electrical disconnection of any other emission-related powertrain component connected to a powertrain control unit / engine control unit / drive train control unit that results in emissions exceeding any of the OBD thresholds in the notification or triggers an operation mode with significantly reduced torque as compared with normal operation.

**8.4.2. Vehicles fitted with compression ignition (CI) engines:**

- 8.4.2.1. After vehicle preconditioning in accordance with Clause 8.2.of this Appendix, the test vehicle is driven in the applicable Type I test.

The malfunction indicator shall activate before the end of this test under any of the conditions in points 8.4.2.2. to 8.4.2.5. The test agency may substitute those conditions by others in accordance with paragraph 8.4.2.5. However, the total number of failures simulated shall not exceed four for the purposes of approval.

- 8.4.2.2. Replacement of a catalytic converter type, where fitted, with a deteriorated or defective catalytic converter or electronic simulation of a deteriorated or defective catalytic converter that results in emissions exceeding any of the OBD thresholds in the notification;
- 8.4.2.3. Total removal of the particulate filter, where fitted, or replacement of the particulate filter with a defective particulate filter meeting the conditions laid down in point 8.4.2.2. that results in emissions exceeding any of the OBD thresholds in the notification;

- 8.4.2.4. With reference to point 8.3.2.5., disconnection of any electronic fuel quantity and timing actuator in the fuelling system that results in emissions exceeding any of the OBD thresholds in the notification;
- 8.4.2.5. With reference to point 8.3.2.5., disconnection of any other powertrain component connected to a powertrain control unit / engine control / drive train control unit that results in emissions exceeding any of the OBD thresholds in the notification or that triggers an operation mode with a significantly reduced torque as compared with normal operation.
- 8.4.3. Replacement of the NO<sub>x</sub> after-treatment system, where fitted, with a deteriorated or defective system or electronic simulation of such a failure.
- 8.4.4. Replacement of the particulate matter monitoring system, where fitted, with a deteriorated or defective system or electronic simulation of such a failure.

**APPENDIX 2.4 TO CHAPTER 6**  
**ADMINISTRATIVE PROVISIONS**

**1.0** The vehicle manufacturer shall fill out the information and submit to the test agency with regard to functional on-board diagnostics and test Type VIII according to the following template.

**2.0** Where documents, diagrams or long descriptions are required the vehicle manufacturer shall attach those as a separate file, appropriately marked in a clear and understandably system and the marking shall be written / typed for all sheets in the space provided.

The following data shall be provided by the vehicle manufacturer.

2.1. On-board diagnostics (OBD) functional requirements

2.1.1. **OBD system general information**

2.1.1.1. Written description or drawing of the Malfunction Indicator (MI);

2.1.2. **List and purpose of all components monitored by the OBD system:**

2.1.2.1. Written description (general working principles) for all OBD stage II circuit (open circuit, shorted low and high, rationality) and electronics (PCU / ECU internal and communication) diagnostics which triggers a default mode in case of fault detection;

2.1.2.2. Written description (general working principles) for all OBD stage II diagnostic functionality triggering any operating mode which triggers a limp-home mode in case of fault detection;

2.1.2.3. Written description of the communication protocol(s) supported;

2.1.2.4. Physical location of diagnostic-connector (add drawings and photographs);

2.1.2.5. Other components than the ones listed in Table 2 of Appendix 2.2 of this chapter monitored by the OBD system;

2.1.2.6. Criteria for MI activation (fixed number of driving cycles or statistical method);

2.1.2.7. List of all OBD output codes and formats used (with explanation of each);

2.1.2.8. OBD compatibility for repair information

The following additional information shall be provided by the vehicle manufacturer to enable the manufacturer of OBD-compatible replacement or service parts, diagnostic tools and test equipment;

- 2.1.2.9. A description of the type and number of the pre-conditioning cycles used for the original approval of the vehicle.
- 2.1.2.10. A comprehensive document describing all sensed components concerned with the strategy for fault detection and MI activation (fixed number of driving cycles or statistical method). This shall, include a list of relevant secondary sensed parameters for each component monitored by the OBD system. The document shall also list all OBD output codes and formats (with an explanation of each) used in association with individual emission-related powertrain components and individual non-emission-related components, where monitoring the component is used to determine MI activation.
- 2.1.2.11. The information required in Clauses 2.1.2.1. to 2.1.2.10. of this Appendix may be provided in table form as described in the following table;

**Example OBD fault-code overview list**

**Table 1**

component	Diagnostic trouble code	Monitoring strategy	Fault detection criteria	MI activation criteria	Secondary parameters	Preconditioning	Demonstration test
Intake air temp. sensor open circuit	P0xx xxxx	Comparison with temperature model after cold start	> 20 degrees difference between measured and modelled intake air temperature	3 <sup>rd</sup> cycle	Coolant and intake air temperature sensor signals	Two type I cycles	Type I

- 2.1.2.12. Description of Electronic Throttle Control (ETC) diagnostic trouble codes;
- 2.1.2.13. Description of default modes and strategies in case of ETC failure;
- 2.1.2.14. Communication protocol information

The following information shall be referenced to a specific vehicle make, model and variant, or identified using other workable definitions such as the Vehicle Identification Number (VIN) or vehicle and systems identification:

- 2.1.2.14.1. Any protocol information system needed to enable complete diagnostics in addition to the standards prescribed in Clause 3.8. of Appendix 2.1 of this Chapter, such as additional hardware or software protocol information, parameter identification, transfer functions, "keep alive" requirements, or error conditions;
- 2.1.2.14.2. Details of how to obtain and interpret all diagnostic trouble codes not in accordance with the standards prescribed in Clause 3.11. of Appendix 2.1 of this Chapter;
- 2.1.2.14.3. A list of all available live data parameters including scaling and access information;
- 2.1.2.14.4. A list of all available functional tests including device activation or control and the means to implement them;
- 2.1.2.14.5. Details of how to obtain all component and status information, time stamps, pending DTC and freeze frames;
- 2.1.2.14.6. Resetting adaptive learning parameters, variant coding and replacement component setup, and customer preferences;
- 2.1.2.14.7. PCU / ECU identification and variant coding;
- 2.1.2.14.8. Details of how to reset service lights;
- 2.1.2.15. Location of diagnostic connector and connector details;
- 2.1.2.16. Engine code identification;
- 2.1.2.17. Test and diagnosis of OBD monitored components:
  - 2.1.2.17.1. A description of tests to confirm its functionality, at the component or in the harness;
  - 2.1.2.17.2. Test procedure including test parameters and component information;
  - 2.1.2.17.3. Connection details including minimum and maximum input and output and driving and loading values;
  - 2.1.2.17.4. Values expected under certain driving conditions including idling;
  - 2.1.2.17.5. Electrical values for the component in its static and dynamic states;
  - 2.1.2.17.6. Failure mode values for each of the above scenarios;
  - 2.1.2.17.7. Failure mode diagnostic sequences including fault trees and guided diagnostics elimination.
- 2.1.3. On-board diagnostics environmental test Type VIII requirements
  - 2.1.3.1. Details of test vehicle(s), its powertrain and pollution-control devices explicitly documented and listed, emission test laboratory equipment and settings.



## CHAPTER 7

### VEHICLE PROPULSION FAMILY AND MODIFICATION OF VEHICLE MODEL WITH REGARD TO ENVIRONMENTAL PERFORMANCE DEMONSTRATION TESTS

#### 1.0 INTRODUCTION

- 1.1 In order to alleviate the test burden on manufacturers when demonstrating the environmental performance of vehicles these may be grouped as a vehicle propulsion family. One or more parent vehicles shall be selected from this group of vehicles by the manufacturer to the satisfaction of the test agency that shall be used to demonstrate environmental performance test Types I – V and VIII.
- 1.2 The vehicle may continue to be regarded as belonging to the same vehicle propulsion family provided that the vehicle variant, version, propulsion, pollution-control system and OBD parameters listed in the Table 1 of this Chapter are identical or remain within the prescribed and declared tolerances.
- 1.3 Vehicle and propulsion family attribution with regard to environmental tests

For the environmental test Types III – V and VIII a representative parent vehicle shall be selected within the boundaries set by the classification criteria laid down in clause 3 of this Chapter.

#### 2.0 MODIFICATIONS OF THE VEHICLE MODEL

- 2.1. Every modification in the essential characteristics, including CVN of the vehicle model shall be intimated by the vehicle manufacturer to the test agency which Type approved the vehicle model. The test agency may either consider that the vehicle with the modifications made may still comply with the requirement, or require a further test to ensure further compliance.
- 2.2. In case of 2.1 above, the testing agency shall extend the Type approval covering the modified specification or the vehicle model shall be subjected to necessary tests. In case, the vehicle complies with the requirements, the test agency shall extend the Type approval.
- 2.3. Any changes to the procedure of PDI and running in concerning emission shall also be intimated to the test agency by the vehicle manufacturer, whenever such changes are carried out.

#### 3.0 MODEL CHANGES (TYPE I & TYPE II TEST)

- 3.1. Vehicle models of Different Reference Weights and coast down coefficients: Approval of a vehicle model may under the following conditions be extended to vehicle models which differ from the Type approved only in respect of their reference weight.

- 3.1.1 Approval may be extended to vehicle model of a reference weight requiring merely the use of the next one higher or any lower equivalent inertia, for 2 wheelers.
- 3.1.2 If the reference weight of the vehicle model for which extension of the Type approval is requested requires the use of a flywheel of equivalent inertia lower than that used for the vehicle model already approved, extension of the Type approval shall be granted if the masses of the pollutants obtained from the vehicle already approved are within the limits prescribed for the vehicle for which extension of the approval is requested.
- 3.1.3 If different body configurations are used with the same power plant and drive line and the change in the load equation due to changes in the coefficient of resistances that is within the limits that would be caused by the change of inertia as permitted by clause 3.1.1 above the approval may be extended.

**3.2 Vehicle models with different overall gear ratios**

- 3.2.1 Approval granted to a vehicle model may under the following conditions be extended to vehicle models differing from the Type approved only in respect of their overall transmission ratios;
  - 3.2.1.1. For each of the transmission ratios used in the Type I Test, it shall be necessary to determine the proportion  $E = (V_2 - V_1)/V_1$ , where  $V_1$  and  $V_2$  are respectively the speed at 1000 rev/min of the engine of the vehicle model Type approved and the speed of the vehicle model for which extension of the approval is requested.
  - 3.2.2. If for each gear ratio  $E \leq 8\%$ , the extension shall be granted without repeating the Type I Tests.
  - 3.2.3. If for at least one gear ratio,  $E > 8\%$  and if for each gear ratio  $E \leq 13\%$  the Type I test must be repeated, but may be performed in laboratory chosen by the manufacturer subject to the approval of the test agency granting Type approval. The report of the tests shall be submitted to the test agency by the manufacturer.

**3.3 Vehicle models of different reference weights, coefficient of coast down and different overall transmission ratios**

- 3.3.1 Approval granted to a vehicle model may be extended to vehicle models differing from the approved type only in respect of their reference weight, coefficient of coast down and their overall transmission ratios, provided that all the conditions prescribed in Para 3.1 and 3.2 above are fulfilled.

**Note:** When a vehicle type has been approved in accordance with the provisions of Para 3.1 to 3.3 above, such approval may not be extended to other vehicle types.

**3.4 Vehicle model with different makes of emission Related components**

3.4.1 The names of suppliers of items such as ignition coil, magneto, CB point, air filter, silencer, spark plug, catalytic converter etc. mentioned above, the manufacturers shall inform the test agency that In addition to carried out the Type approval, the names of new alternate suppliers for these items as and when they are being introduced.

3.4.2 At the time of first Type approval or for a subsequent addition of a make for a particular part, work out the combinations of tests in such a way that each make of such parts are tested at least once.

**3.5 Classification criteria**

3.5.1 Approvals granted to the vehicle type may be extended to Test Types III, IV and V ('X' in Table 1 of this chapter means 'applicable') as per following table:

<b>Table 1</b>				
<b>Classification criteria propulsion family with regard to test Types III, IV and V</b>				
<b>#</b>	<b>Classification criteria description</b>	<b>Test Type III</b>	<b>Test Type IV</b>	<b>Test Type V</b>
<b>1.0</b>	<b>VEHICLE</b>			
1.1	Class	X	X	X
1.2	the inertia of a vehicle variant(s) within two inertia categories above or below the nominal inertia category;			X
1.3	Overall gear ratios (+/- 8 %);			X
<b>2.0</b>	<b>PROPULSION FAMILY CHARACTERISTICS</b>			
2.1	number of engines	-	-	X
2.2	hybrid operation mode(s) (parallel / sequential / other);-	-	-	X
2.3	number of cylinders of the combustion engine;	-	-	X
2.4	engine capacity (+/- 2 %) <sup>(2)</sup> of the combustion engine	-	-	X
2.5	number and control (variable cam phasing or lift) of combustion engine valves;	-	-	X
2.6	monofuel / Bifuel / flex fuel HCNG / multifuel;	-	-	X
2.7	fuel system (carburettor / scavenging port / port fuel injection / direct fuel injection / common rail / pump-injector / other);	-	-	X
2.8	fuel storage <sup>(3)</sup> ;	-	-	-
2.9	type of cooling system of combustion engine;	-	-	X
2.10.	combustion cycle (PI / CI / two-stroke / four-stroke / other);	-	-	X

2.11	intake air system (naturally aspirated / charged (turbocharger / super-charger) / intercooler / boost control) and air induction control (mechanical throttle / electronic throttle control / no throttle);	-	-	X
2.12	propulsion (not) equipped with crankcase ventilation system;	X	-	-
2.12.1	crankcase ventilation system type;	X	-	-
2.12.2	operation principle of crank case ventilation system (breather / vacuum / overpressure);	X	-	-
2.13	Propulsion (not) equipped with evaporative emission control system	-	X	-
2.13.1	Evaporative emission control system type;	-	X	-
2.13.2	Operation principle of evaporative emission control system (active / passive / mechanically or electronically controlled);	-	X	-
2.13.3	Identical basic principle of fuel/air metering (e.g. carburettor / single point injection / multi point injection / engine speed density through MAP/ mass airflow);	-	X	-
2.13.4	Identical material of the fuel tank <sup>(4)</sup> ;	-	X	-
2.13.5	Liquid fuel hoses are identical and the surface area is lower;	-	X	-
2.13.6	The fuel storage capacity declared by the manufacturer is within a range of +10 / - 50 % of the nominal fuel tank volume	-	X	-
	If the test agency determines that, with regard to the fuel storage capacity, the parent vehicle does not fully represent the family, an alternative or additional vehicle may be selected.	-	-	-
2.13.7	The fuel storage relief valve pressure setting is identical or higher;	-	X	-
2.13.8	Identical method of storage of the fuel vapour (i.e. trap form and volume, storage medium, air cleaner (if used for evaporative emission control) etc.); As per EU 134	-	X	-

2.13.9	Identical or higher volume of the carbon canister <sup>2</sup> ;	-	X	-
2.13.10	Identical method of purging of the stored vapour (e.g. air flow, purge volume over the driving cycle);	-	X	-
2.13.11	Identical method of sealing and venting of the fuel metering system;	-	X	-
<b>3.0</b>	<b>POLLUTION CONTROL SYSTEM CHARACTERISTICS</b>			
3.1.	Propulsion exhaust (not) equipped with catalytic converter(s);	-	-	X
3.2.	Catalytic converter(s) type;	-	-	X
3.2.1	Number and elements of catalytic converters;	-	-	X
3.2.2	Size of catalytic converters (volume of monolith(s) +/- 15 %);	-	-	X
3.2.3	Operation principle of catalytic activity (oxidising, three-way, heated, SCR, other.);	-	-	X
3.2.4	Precious metal load (identical or higher);	-	-	X
3.2.5	Precious metal ratio (+/- 15 %);	-	-	X
3.2.6	substrate (structure and material);	-	-	X
3.2.7	cell density;	-	-	X
3.2.8	type of casing for the catalytic converter(s);	-	-	X
3.3	<b>propulsion exhaust (not) equipped with particulate filter (PF)</b>	-	-	X
3.3.1	PF types;	-	-	X
3.3.2	Number and elements of PF;	-	-	X
3.3.3	Size of PF (volume of filter element +/- 10 %);	-	-	X
3.3.4	Operation principle of PF (partial / wall-flow / other);	-	-	X
3.3.5	Active surface of PF;	-	-	X
3.4	<b>Propulsion (not) equipped with periodically regenerating system;</b>	-	-	X
3.4.1	periodically regenerating system type;	-	-	X

3.4.2	operation principle of periodically regenerating system;	-	-	X
3.5	<b>propulsion (not) equipped with selective catalytic converter reduction (SCR) system;</b>	-	-	X
3.5.1	SCR system type;	-	-	X
3.5.2	operation principle of periodically regenerating system;	-	-	X
3.6	<b>propulsion (not) equipped with lean NO<sub>x</sub> trap /absorber;</b>	-	-	X
3.6.1	lean NO <sub>x</sub> trap / absorber type;	-	-	X
3.6.2	Operation principle of lean NO <sub>x</sub> trap / absorber;	-	-	X
3.7	<b>Propulsion (not) equipped with a cold-start device or starting aid device(s);</b>	-	-	X
3.7.1	cold-start or starting aid device type;	-	-	X
3.7.2	operation principle of cold start or starting aid device(s);	-	-	X
3.7.3	Activation time of cold-start or starting aid device(s) and /or duty cycle (only limited time activated after cold start / continuous operation);	-	-	X
3.8	<b>propulsion (not) equipped with O<sub>2</sub> sensor for fuel control;</b>	-	-	X
3.8.1	O <sub>2</sub> exhaust sensor types;	-	-	X
3.8.2	operation principle of O <sub>2</sub> exhaust sensor (binary / wide range / other);	-	-	X
3.8.3	O <sub>2</sub> exhaust sensor interaction with closed-loop fuelling system (stoichiometry / lean or rich operation);	-	-	X
3.9	<b>propulsion (not) equipped with exhaust gas recirculation (EGR) system;</b>	-	-	X
3.9.1	EGR system types;	-	-	X
3.9.2	operation principle of EGR system (internal / external);	-	-	X
3.9.3	Maximum EGR rate (+/- 5 %);	-	-	X

#	Classification criteria description	Test Type VIII	
		Stage I	Stage II
<b>1.0</b>	<b>VEHICLE</b>		
1.1	Class	X	X
1.2	the inertia of a vehicle variant(s) or version(s) within two inertia categories above or below the nominal inertia category;	X	X
1.3	Overall gear ratios (+/- 8 %);	X	X
<b>2.0</b>	<b>PROPULSION FAMILY CHARACTERISTICS</b>		
2.1	number of engines	X	X
2.2	reserved		
2.3	number of cylinders of the combustion engine;	X	X
2.4	engine capacity (+/- 2 %) <sup>(2)</sup> of the combustion engine	X	X
2.4.1	engine capacity (+/- 30 %) of the combustion engine	X	-
2.5	number and control (variable cam phasing or lift) of combustion engine valves;	X	X
2.6	monofuel / Bifuel / flex fuel HCNG / multifuel;	X	X
2.7	fuel system (carburettor / scavenging port / port fuel injection / direct fuel injection / common rail / pump-injector / other);	X	X
2.8	fuel storage <sup>(3)</sup> ;	X	X
2.9	type of cooling system of combustion engine;	X	X
2.10.	combustion cycle (PI / CI / two-stroke / four-stroke / other);	X	X
2.11	intake air system (naturally aspirated / charged (turbocharger / super-charger) / intercooler / boost control) and air induction control (mechanical throttle / electronic throttle control / no throttle);	X	X
<b>3.0</b>	<b>POLLUTION CONTROL SYSTEM CHARACTERISTICS</b>		
3.1.	Propulsion exhaust (not) equipped with catalytic converter(s);		X



3.2.	Catalytic converter(s) type;		X
3.2.1	Number and elements of catalytic converters;		X
3.2.2	Size of catalytic converters (volume of monolith(s) +/- 15 %);		X
3.2.3	Operation principle of catalytic activity (oxidising, three-way, heated, SCR, other.);		X
3.2.4	Precious metal load (identical or higher);		X
3.2.5	Precious metal ratio (+/- 15 %);		X
3.2.6	substrate (structure and material);		X
3.2.7	cell density;		X
3.2.8	type of casing for the catalytic converter(s);		X
3.3	<b>Propulsion exhaust (not) equipped with particulate filter (pf);</b>		
3.3.1	PF types;		X
3.3.2	Number and elements of PF;		X
3.3.3	Size of PF (volume of filter element +/- 10 %);		X
3.3.4	Operation principle of PF (partial / wall-flow / other);		X
3.3.5	Active surface of PF;		X
3.4	<b>Propulsion (not) equipped with periodically regenerating system;</b>		
3.4.1	periodically regenerating system type;		X
3.4.2	operation principle of periodically regenerating system;		X
3.5	<b>propulsion (not) equipped with selective catalytic converter reduction (SCR) system;</b>		
3.5.1	SCR system type;		X
3.5.2	operation principle of periodically regenerating system;		X
3.6	<b>propulsion (not) equipped with lean NO<sub>x</sub> trap /absorber;</b>		
3.6.1	lean NO <sub>x</sub> trap / absorber type;		X
3.6.2	Operation principle of lean NO <sub>x</sub> trap / absorber;		X

3.7	<b>Propulsion (not) equipped with a cold-start device or starting AID device(s);</b>		
3.7.1	cold-start or starting aid device type;		X
3.7.2	operation principle of cold start or starting aid device(s);	X	X
3.7.3	Activation time of cold-start or starting aid device(s) and /or duty cycle (only limited time activated after cold start / continuous operation);	X	X
3.8	<b>Propulsion (not) equipped with O<sub>2</sub> sensor for fuel control;</b>		
3.8.1	O <sub>2</sub> exhaust sensor types;	X	X
3.8.2	operation principle of O <sub>2</sub> exhaust sensor (binary / wide range / other);	X	X
3.8.3	O <sub>2</sub> exhaust sensor interaction with closed-loop fuelling system (stoichiometry / lean or rich operation);	X	X
3.9	<b>Propulsion (not) equipped with Exhaust Gas Recirculation (EGR) system;</b>		
3.9.1	EGR system types;	-	X
3.9.2	operation principle of EGR system (internal / external);	-	X
3.9.3	Maximum EGR rate (+/- 5 %);	-	X

Explanatory notes:

(<sup>1</sup>) For Type IV test, two-wheeled motorcycles and two-wheeled motorcycles with sidecars are considered to be of the same family.

(<sup>2</sup>) Maximum 30% acceptable for test Type VIII.

(<sup>3</sup>) Only for vehicles equipped with storage for gaseous fuel.

(<sup>4</sup>) Material of all metallic fuel tanks are considered to be identical.

**Note:** 1. For each of the transmission ratios used in the Type I Test, it shall be necessary to determine the proportion  $E = (V2 - V1)/V1$ , where V1 and V2 are respectively the speed at 1000 rev/min of the engine of the vehicle model Type approved and the speed of the vehicle model for which extension of the approval is requested. If for each gear ratio  $E < \pm 8\%$ , the extension shall be granted without repeating the Type I Tests.

**3.6 On-board diagnostics family**

**3.6.1 Selection criteria :**

Vehicle types for which at least the parameters described below are identical are considered to belong to the same engine/emission control/OBD system combination.

**3.6.1.1 Engine:**

- combustion process (i.e. positive-ignition/compression-ignition, two stroke/four stroke/rotary),
- method of engine fuelling (i.e. single or multi-point fuel injection),
- fuel type (i.e. petrol, diesel, flex fuel petrol/ethanol, flex fuel diesel/biodiesel, NG/biomethane, LPG, bi fuel petrol/NG/biomethane, bi fuel petrol/LPG),

**3.6.1.2 Emission control system:**

- type of catalytic converter (i. e. oxidation, three-way, heated catalyst, SCR, other),
- type of particulate trap,
- secondary air injection (i.e. with or without),
- exhaust gas recirculation (i.e. with or without),

**3.6.1.3 OBD parts and functioning:**

- the methods of OBD functional monitoring, malfunction detection and malfunction indication to the vehicle driver.

**4.0 EXTENSION OF TYPE-APPROVAL REGARDING TEST TYPE IV**

4.1 The Type-approval shall be extended to vehicles equipped with a control system for evaporative emissions which meet the evaporative emission control family classification criteria. The worst-case vehicle with regard to the cross-section and approximate hose length shall be tested as a parent vehicle.

4.2. if the vehicle manufacturer has certified a fuel tank of generic shape ('parent fuel tank'), these test data may be used to certify 'by design' any other fuel tank provided that it is designed with the same characteristics as regards material (including additives), method of production and average wall thickness.

**CHAPTER 8****TEST TYPE VII REQUIREMENTS ENERGY EFFICIENCY: CO<sub>2</sub> EMISSIONS, FUEL CONSUMPTION, ELECTRIC ENERGY CONSUMPTION AND ELECTRIC RANGE****1.0 INTRODUCTION**

- 1.1. This Chapter sets out requirements with regard to energy efficiency of L2-category vehicles, in particular with respect to the measurement of CO<sub>2</sub> emissions, fuel or energy consumption as well as the electric range of a vehicle.
- 1.2. The requirements laid down in this chapter apply to the following tests of L2-category vehicles equipped with associated power train configurations:
  - (a) the measurement of the emission of carbon dioxide (CO<sub>2</sub>) and fuel consumption, the measurement of electric energy consumption and the electric range of L2-category vehicles powered by a combustion engine only or by a hybrid electric powertrain.
  - (b) the measurement of electric energy consumption and electric range of L2-category vehicles powered by an electric power train only.

**2.0 SPECIFICATION AND TESTS****2.1. General**

The components liable to affect CO<sub>2</sub> emissions and fuel consumption or the electric energy consumption shall be so designed, constructed and assembled as to enable the vehicle, in normal use, despite the vibrations to which it may be subjected, to comply with the provisions of this Chapter .

**2.2. Description of tests for vehicles powered by a hybrid electric powertrain**

- 2.2.1. The test agency in charge of the tests shall measure the CO<sub>2</sub> emissions and the electric energy consumption according to the test procedure described in Appendix 1 of this Chapter.
- 2.2.2. The test results for CO<sub>2</sub> emissions shall be expressed in grams per kilometre (g/km) rounded to the nearest whole number.
- 2.2.3. The fuel consumption, expressed in litres per 100 km (in the case of petrol, LPG, ethanol (E85) and diesel) or in kg and m<sup>3</sup> per 100 km (in the case of NG/biomethane, H<sub>2</sub>NG and hydrogen), shall be calculated according to clause 1.4.3. of chapter 2 by the carbon balance method using the CO<sub>2</sub> emissions measured and the other carbon- related emissions (CO and HC). The results shall be rounded to the first decimal place

- 2.2.4. For the purpose of the calculation referred to in clause 2.2.3. of this Chapter, the prescriptions.
- 2.2.5. If applicable, electric energy consumption shall be expressed in Watt hours per kilometer (Wh/km), rounded to the nearest whole number.
- 2.2.6. The test agency in charge of the tests shall measure the electric range of the vehicle according to the method described in Appendix 1.3 of this Chapter. The result shall be expressed in kilometer, rounded to the nearest whole number.

The electric range measured by this method shall be the only one referred to in promotional material and used for the calculations in Appendix 1 of this Chapter

### 2.3. **Interpretation of test results**

- 2.3.1. The CO<sub>2</sub> value or the value of electric energy consumption adopted as the Type-approval value shall be that declared by the manufacturer if this is not exceeded by more than 4 percent by the value measured by the test agency. The measured value may be lower without any limitations

In the case of vehicles powered by a combustion engine only which are equipped with periodically regenerating systems as defined in clause 3.1.114 of Chapter 1, the results are multiplied by the factor Ki obtained from Appendix 10 to Chapter 2 before being compared with the declared value.

- 2.3.2. If the measured value of CO<sub>2</sub> emissions or electric energy consumption exceeds the manufacturer's declared CO<sub>2</sub> emissions or electric energy consumption value by more than 4 percent, another test shall be run on the same vehicle.

Where the average of the two test results does not exceed the manufacturer's declared value by more than 4 percent, the value declared by the manufacturer shall be taken as the Type-approval value.

- 2.3.3. If, in the event of another test being run, the average still exceeds the declared value by more than 4 percent, a final test shall be run on the same vehicle. The average of the three test results shall be taken as the Type-approval value.

## APPENDIX 1 CHAPTER 8

### METHOD OF MEASURING THE CARBON DIOXIDE EMISSIONS, FUEL CONSUMPTION, ELECTRIC ENERGY CONSUMPTION AND DRIVING RANGE OF VEHICLES POWERED BY A HYBRID ELECTRIC POWERTRAIN

#### 1.0 INTRODUCTION

1.1 This Appendix lays down specific provisions on the Type-approval of hybrid electric L2-category vehicles (HEV) as regards measuring carbon dioxide emissions, fuel consumption, electric energy consumption and driving range

1.2 As a general principle for Type VII tests, HEVs shall be tested according to the specified Type I test cycles and requirements and in particular Appendix 6 to Chapter 2, except where modified by this Appendix.

1.3. OVC (externally chargeable) HEVs shall be tested under Conditions A and B.

The test results under Conditions A and B and the weighted average referred to in Clause 3 shall be given in the test report.

1.4. Driving cycles and gear-shift points

1.4.1. The driving cycle in Appendix 6 of Chapter 2 is applicable at the time of approval of the vehicle shall be used, including the gear-shifting points in Clause 4.5.5. of Chapter 2.

1.4.4. For vehicle conditioning, a combination of the driving cycles in Appendix 6 to Chapter 2 applicable at the time of approval of the vehicle shall be used as laid down in this Appendix.

#### 2.0 CATEGORIES OF HYBRID ELECTRIC VEHICLES (HEV)

<b>Table 1</b>				
<b>Vehicle Charging</b>	<b>Off-Vehicle Charging ( 1 ) (OVC)</b>		<b>Not-off-vehicles (2) (NOVC)</b>	
Operating mode switch	Without	with	without	with
( 1 ) Also known as 'externally chargeable' ( 2 ) Also known as 'not externally chargeable'.				

#### 3.0 OVC (externally chargeable) HEV without an operating mode switch

3.1. Two Type I tests shall be performed under the following conditions:

(a) Condition A: the test shall be carried out with a fully charged electrical energy/power storage device;

- (b) Condition B: the test shall be carried out with an electrical energy/power storage device in minimum state of charge (maximum discharge of capacity).

The profile of the state of charge (SOC) of the electrical energy/power storage device at different stages of the test is set out in Appendix 1.1 of this Chapter.

### 3.2. Condition A

- 3.2.1. The procedure shall start with the discharge of the electrical energy/power storage device in accordance with Clause 3.2.1.1. of this Appendix:

#### 3.2.1.1. Discharge of the electrical energy/power storage device

The electrical energy/power storage device of the vehicle is discharged while driving (on the test track, on a chassis dynamometer, etc.) in any of the following conditions:

- at a steady speed of 50 km/h until the fuel-consuming engine starts up,
- if a vehicle cannot reach a steady speed of 50 km/h without the fuel-consuming engine starting up, the speed shall be reduced until it can run at a lower steady speed at which the fuel-consuming engine does not start up for a defined time or distance (to be determined by the technical service and the manufacturer to the satisfaction of the approval authority),
- in accordance with the manufacturer's recommendation

The fuel-consuming engine shall be stopped within ten seconds of being automatically started.

#### 3.2.2. Conditioning of the vehicle

- 3.2.2.1. The test vehicle shall be preconditioned by conducting the applicable type I test cycle in combination with the applicable gear-shifting in Clause 4.4.2.3. of Chapter 2.

- 3.2.2.2. After this preconditioning and before testing, the vehicle shall be kept in a room in which the temperature remains relatively constant between 293.3K and 303.3K (20 °C and 30 °C). This conditioning shall be carried out for at least six hours and continue until the temperatures of the engine oil and coolant, if any, are within  $\pm 2^{\circ}\text{C}$  of the temperature of the room, and the electrical energy/power storage device is fully charged as a result of the charging in Clause 3.2.2.4.

- 3.2.2.3. During soak, the electrical energy/power storage device shall be charged in accordance with the normal overnight charging procedure described in Clause 3.2.2.4.

- 3.2.2.4. Application of a normal overnight charge  
The electrical energy/power storage device shall be charged according to the following procedure
- 3.2.2.4.1. Normal overnight charge procedure  
The charging shall be carried out as follows:
- (a) with the on-board charger, if fitted or
  - (b) with an external charger recommended by the manufacturer using the charging pattern prescribed for normal charging; and
  - (c) in an ambient temperature of between 20°C and 30°C. This procedure shall exclude all types of special charge that could be automatically or manually initiated, e.g. equalization or servicing charges. The manufacturer shall declare that no special charge procedure has occurred during the test.
- 3.2.2.4.2. End-of-charge criteria  
The end-of-charge criteria shall correspond to a charging time of twelve hours, except where the standard instrumentation indicates clearly that the electrical energy/power storage device is not yet fully charged, in which case:
- Equation 1:
- $$\text{The maximum time is} = \frac{\text{3. claimed battery capacity(Wh)}}{\text{Mains power supply (W)}}$$
- 3.2.3. Test procedure
- 3.2.3.1. The vehicle shall be started up by the means provided for normal use by the driver. The first cycle starts on the initiation of the vehicle start-up procedure
- 3.2.3.2. The test procedures defined in either Clause 3.2.3.2.1. or 3.2.3.2.2. of this Appendix may be used.
- 3.2.3.2.1. Sampling shall begin (BS) before or at the initiation of the vehicle start-up procedure and end on conclusion of the final idling period in the applicable Type I driving cycle (end of sampling (ES)).
- 3.2.3.2.2. Sampling shall begin (BS) before or at the initiation of the vehicle start-up procedure and continue over a number of repeat test cycles. It shall end on conclusion of the applicable Type I driving cycle during which the battery reached the minimum state of charge in accordance with the following procedure (end of sampling (ES)):
- 3.2.3.2.2.1. The electricity balance Q (Ah) is measured over each combined cycle, using the procedure in Appendix 1.2.of this Chapter, and used to determine when the battery's minimum state of charge has been reached.



- 3.2.3.2.2.2. The battery's minimum state of charge is considered to have been reached in combined cycle N if the electricity balance Q measured during combined cycle N + 1 is not more than a 3 percent discharge, expressed as a percentage of the nominal capacity of the battery (in Ah) in its maximum state of charge, as declared by the manufacturer. At the manufacturer's request, additional test cycles may be run and their results included in the calculations in points 3.2.3.5. and 3.4. of this Appendix, provided that the electricity balance for each additional test cycle shows less discharge of the battery than over the previous cycle.
- 3.2.3.2.2.3. Between each pair of cycles, a hot soak period of up to ten minutes is allowed. The powertrain shall be switched off during this period.
- 3.2.3.3. The vehicle shall be driven according to the applicable Type I driving cycle and gear-shifting prescriptions in Chapter 2.
- 3.2.3.4. The tailpipe emissions of the vehicle shall be analyzed according to the provisions of Chapter 2 in force at the time of approval of the vehicle.
- 3.2.3.5. The CO<sub>2</sub> emission and fuel consumption results from the test cycle(s) for Condition A shall be recorded (respectively m<sub>1</sub> (g) and c<sub>1</sub> (l)). Parameters m<sub>1</sub> and c<sub>1</sub> shall be the sums of the results of the N combined cycles run.

Equation 2: 
$$m_1 = \sum_1^N m_i$$

Equation 3: 
$$c_1 = \sum_1^n c_i$$

- 3.2.4. Within the 30 minutes after the conclusion of the cycle, the electrical energy/power storage device shall be charged according to Clause 3.2.2.4. The energy measurement equipment, placed between the mains socket and the vehicle charger, measures the charge energy e<sub>1</sub> (Wh) delivered from the mains.
- 3.2.5. The electric energy consumption for Condition A shall be e<sub>1</sub> (Wh).

### 3.3. **Condition B**

#### 3.3.1. Conditioning of the vehicle

- 3.3.1.1. The electrical energy/power storage device of the vehicle shall be discharged in accordance with Clause 3.2.1.1 of this Appendix. At the manufacturer's request, a conditioning in accordance with Clause 3.2.2.1. may be carried out before electrical energy/power storage discharge.
- 3.3.1.2. Before testing, the vehicle shall be kept in a room in which the temperature remains relatively constant between 293K and 303K (20°C and 30°C). This conditioning shall be carried out for at least six hours and continue until the temperatures of the engine oil and coolant, if any, are within ± 2K (± 2°C) of the temperature of the room.

- 3.3.2. Test procedure
- 3.3.2.1. The vehicle shall be started up by the means provided for normal use by the driver. The first cycle starts on the initiation of the vehicle start-up procedure
- 3.3.2.2. Sampling shall begin (BS) before or at the initiation of the vehicle start-up procedure and end on conclusion of the final idling period in the applicable Type I driving cycle (end of sampling (ES)).
- 3.3.2.3. The vehicle shall be driven using the applicable Type I driving cycle and gear-shifting prescriptions set out in Appendix 6 of Chapter 2.
- 3.3.2.4. The tailpipe emissions of the vehicle shall be analyzed according to the provisions of Chapter 2.
- 3.3.2.5. The test results for Condition B shall be recorded ( $m_2$  (g) and  $c_2$  (l) respectively).
- 3.3.3. Within 30 minutes of the end of the cycle, the electrical energy/power storage device shall be charged in accordance with Clause 3.2.2.4 of this Appendix.
- The energy measurement equipment, placed between the mains socket and the vehicle charger, measures the energy charge  $e_2$  (Wh) delivered from the mains.
- 3.3.4. The electrical energy/power storage device of the vehicle shall be discharged in accordance with Clause 3.2.1.1 of this Appendix.
- 3.3.5. Within 30 minutes of the discharge, the electrical energy/power storage device shall be charged in accordance with Clause 3.2.2.4 of this Appendix.
- The energy measurement equipment, placed between the mains socket and the vehicle charger, measures the energy charge  $e_3$  (Wh) delivered from the mains.
- 3.3.6. The electric energy consumption  $e_4$  (Wh) for Condition B is:

$$\text{Equation 4: } e_4 = e_2 - e_3$$

### 3.4. Test results

- 3.4.1. The CO<sub>2</sub> values shall be:

$$\text{Equation 5: } M_1 = m_1 / D_{\text{test1}} \text{ (g/km) and}$$

$$\text{Equation 6: } M_2 = m_2 / D_{\text{test2}} \text{ (g/km)}$$

where:

$D_{\text{test1}}$  and  $D_{\text{test2}}$  = the actual distances driven in the tests performed under Conditions A (clause 3.2.) and B (clause 3.3.) respectively, and  $m_1$  and  $m_2$  = test results determined in clauses 3.2.3.5. and 3.3.2.5 of this Appendix respectively.

3.4.2.1. For testing in accordance with clause 3.2.3.2.1 of this Appendix

The weighted CO<sub>2</sub> values shall be calculated as follows:

Equation 7:

$$M = (D_e \cdot M_1 + D_{av} \cdot M_2) / (D_e + D_{av})$$

where:

M = mass emission of CO<sub>2</sub> in grams per kilometer,

M<sub>1</sub> = mass emission of CO<sub>2</sub> in grams per kilometer with a fully charged electrical energy device/REESS ,

M<sub>2</sub> = mass emission of CO<sub>2</sub> in grams per kilometer with an electrical energy device/REESS in minimum state of charge (maximum discharge of capacity),

D<sub>e</sub> = electric range of the vehicle determined according to the procedure described in Appendix 1.3., where the manufacturer shall provide the means for performing the measurement with the vehicle running in pure electric operating state,

D<sub>av</sub> = average distance between two battery recharges, D<sub>av</sub> =:

- 25 km for an L5-category vehicle with an engine capacity of < 150 cm<sup>3</sup>;
- 25 km for an L5-category vehicle with an engine capacity of ≥ 150 cm<sup>3</sup> and v max < 130 km/h;
- 25 km for an L5-category vehicle with an engine capacity of ≥ 150 cm<sup>3</sup> and v max ≥ 130 km/h.

3.4.2.2. For testing in accordance with clause 3.2.3.2.2 of this Appendix

Equation 8:

$$M = (D_{ovc} \cdot M_1 + D_{av} \cdot M_2) / (D_{ovc} + D_{av})$$

where:

M = mass emission of CO<sub>2</sub> in grams per kilometer,

M<sub>1</sub> = mass emission of CO<sub>2</sub> in grams per kilometer with a fully charged electrical energy device/REESS ,

M<sub>2</sub> = mass emission of CO<sub>2</sub> in grams per kilometer with an electrical energy device/REESS in minimum state of charge (maximum discharge of capacity),

$D_{ovc}$  = OVC range according to the procedure described in Appendix 1.3,

$D_{av}$  = average distance between two battery recharges,  $D_{av}$  =:

- 25 km for an L5-category vehicle with an engine capacity of  $< 150 \text{ cm}^3$ ;
- 25 km for an L5-category vehicle with an engine capacity of  $\geq 150 \text{ cm}^3$  and  $v_{max} < 130 \text{ km/h}$ ;
- 25 km for an L5-category vehicle with an engine capacity of  $\geq 150 \text{ cm}^3$  and  $v_{max} \geq 130 \text{ km/h}$

[**Note:**  $D_{av}$  is changed to align with AIS-102 and FAME incentive notification S.O.830(E)]

3.4.3. The fuel consumption values shall be:

Equation 9:

$$C_1 = \frac{100 * c_1}{D_{test1}}$$

Equation 10:

$$C_2 = \frac{100 * c_2}{D_{test2}}$$

(l/100 km) for liquid fuels and (kg/100) km for gaseous fuel

where:

$D_{test1}$  and  $D_{test2}$  = the actual distances driven in the tests performed under Conditions A (clause 3.2.) and B (clause 3.3.) respectively, and

$C_1$  and  $C_2$  = test results determined in clauses 3.2.3.8. and 3.3.2.5 of this Appendix respectively.

3.4.4. The weighted fuel consumption values shall be calculated as follows:

3.4.4.1. For testing in accordance with clause 3.2.3.2.1 of this Appendix

Equation 11:

$$C = \frac{D_e \cdot C_1 + D_{av} \cdot C_2}{D_e + D_{av}}$$

where:

$C$  = fuel consumption in l/100 km,

$C_1$  = fuel consumption in l/100 km with a fully charged electrical energy device/REESS ,

$C_2$  = fuel consumption in l/100 km with an electrical energy device/REESS in minimum state of charge (maximum discharge of capacity),

$D_e$  = electric range of the vehicle determined according to the procedure described in Appendix 1.3., where the manufacturer shall provide the means for performing the measurement with the vehicle running in pure electric operating state,

$D_{av}$  = average distance between two battery recharges,  $D_{av}$  =:

- 25 km for an L5-category vehicle with an engine capacity of  $< 150 \text{ cm}^3$ ;
- 25 km for an L5-category vehicle with an engine capacity of  $\geq 150 \text{ cm}^3$  and  $v_{\text{max}} < 130 \text{ km/h}$ ;
- 25 km for an L5-category vehicle with an engine capacity of  $\geq 150 \text{ cm}^3$  and  $v_{\text{max}} \geq 130 \text{ km/h}$ .

[**Note:**  $D_{av}$  is changed to align with AIS-102 and FAME incentive notification S.O.830(E)]

3.4.4.2. For testing in accordance with clause 3.2.3.2.2 of this Appendix

Equation 12:

$$C = (D_{ovc} \cdot C_1 + D_{av} \cdot C_2) / (D_{ovc} + D_{av})$$

where:

$C$  = fuel consumption in l/100 km,

$C_1$  = fuel consumption in l/100 km with a fully charged electrical energy device/REESS ,

$C_2$  = fuel consumption in l/100 km with an electrical energy device/REESS in minimum state of charge (maximum discharge of capacity),

$D_{ovc}$  = OVC range according to the procedure described in Appendix 1.3 of chapter 9.

$D_{av}$  = average distance between two battery recharges,  $D_{av}$  =:

- 25 km for an L5-category vehicle with an engine capacity of  $< 150 \text{ cm}^3$ ;
- 25 km for an L5-category vehicle with an engine capacity of  $\geq 150 \text{ cm}^3$  and  $v_{\text{max}} < 130 \text{ km/h}$ ;
- 25 km for an L5-category vehicle with an engine capacity of  $\geq 150 \text{ cm}^3$  and  $v_{\text{max}} \geq 130 \text{ km/h}$ .

[**Note:**  $D_{av}$  is changed to align with AIS-102 and FAME incentive notification S.O.830(E)]

3.4.5. The electric energy consumption values shall be:

Equation 13:

$$E_1 = e_1 / D_{\text{test1}} \text{ and}$$

Equation 14:

$$E_4 = \frac{e_2}{D_{\text{test2}}}$$

(Wh/km)

with  $D_{\text{test1}}$  and  $D_{\text{test2}}$  the actual distances driven in the tests performed under Conditions A (clause 3.2 of this Appendix) and B (clause 3.3 of this Appendix) respectively, and  $e_1$  and  $E_4$  determined in clauses 3.2.5. and 3.3.6 of this Appendix respectively.

3.4.6. The weighted electric energy consumption values shall be calculated as follows:

3.4.6.1 For testing in accordance with clause 3.2.3.2.1 of this Appendix;

Equation 15:

$$E = \frac{D_e \cdot E_1 + D_{av} \cdot E_4}{D_e + D_{av}}$$

where:

$E$  = electric consumption Wh/km,

$E_1$  = electric consumption Wh/km with a fully charged electrical energy device/REESS ,

$E_4$  = electric consumption Wh/km with an electrical energy device/REESS in minimum state of charge (maximum discharge of capacity),

$D_e$  = electric range of the vehicle determined according to the procedure described in Appendix 1.3. of this Chapter, where the manufacturer shall provide the means for performing the measurement with the vehicle running in pure electric operating state,

$D_{av}$  = average distance between two battery recharges,  $D_{av} =$ :

- 25 km for an L5-category vehicle with an engine capacity of  $< 150 \text{ cm}^3$ ;
- 25 km for an L5-category vehicle with an engine capacity of  $\geq 150 \text{ cm}^3$  and  $v_{\text{max}} < 130 \text{ km/h}$ ;
- 25 km for an L5-category vehicle with an engine capacity of  $\geq 150 \text{ cm}^3$  and  $v_{\text{max}} \geq 130 \text{ km/h}$ .

[**Note:**  $D_{av}$  is changed to align with AIS-102 and FAME incentive notification S.O.830(E)]

3.4.6.2. For testing in accordance with clause 3.2.3.2.2 of this Appendix

Equation 16:

$$E = \frac{D_{OVC} \cdot E_1 + D_{av} \cdot E_4}{D_{OVC} + D_{av}}$$

where:

E = electric consumption Wh/km,

E<sub>1</sub> = electric consumption Wh/km with a fully charged electrical energy device/REESS ,

E<sub>4</sub> = electric consumption Wh/km with an electrical energy device/REESS in minimum state of charge (maximum discharge of capacity),

D<sub>ovc</sub> = OVC range according to the procedure described in Appendix 1.3.

D<sub>av</sub> = average distance between two battery recharges, D<sub>av</sub> =:

- 25 km for an L5-category vehicle with an engine capacity of < 150 cm<sup>3</sup>;
- 25 km for an L5-category vehicle with an engine capacity of ≥ 150 cm<sup>3</sup> and v max < 130 km/h;
- 25 km for an L5-category vehicle with an engine capacity of ≥ 150 cm<sup>3</sup> and v max ≥ 130 km/h.

[**Note:** D<sub>av</sub> is changed to align with AIS-102 and FAME incentive notification S.O.830(E)]

#### **4.0 EXTERNALLY CHARGEABLE (OVC HEV) WITH AN OPERATING MODE SWITCH**

4.1 Two tests shall be performed under the following conditions:

4.1.1. Condition A: test carried out with a fully charged electrical energy device/REESS.

4.1.2. Condition B: test carried out with an electrical energy device/REESS in minimum state of charge (maximum discharge of capacity).

4.1.3. The operating mode switch shall be positioned in accordance with Table 2, clause 3.2.1.3. of Appendix 11 of chapter 2.

#### **4.2. Condition A**

4.2.1 If the electric range of the vehicle, as measured in accordance with Appendix 1.3. of this chapter, is higher than one complete cycle, the Type I test for electric energy measurement may be carried out in pure electric mode at the request of the manufacturer after agreement of the test agency and to the satisfaction of the test agency. In this case, the values of M1 and C<sub>1</sub> in clause 4.4. of this Appendix shall be taken as equal to 0.

4.2.2. The procedure shall start with the discharge of the electrical energy device/REESS of the vehicle as described in clause 4.2.2.1 of this Appendix

4.2.2.1. The electrical energy device/REESS of the vehicle is discharged while driving with the switch in pure electric position (on the test track, on a chassis dynamometer, etc.) at a steady speed of 70 percent  $\pm$  5 percent of the maximum design vehicle speed in pure electric mode, determined in accordance with the test procedure to measure the maximum design vehicle speed set out in AIS-137 – Part 5.

Discharge shall stop in any of the following conditions:

- when the vehicle is unable to run at 65 percent of the maximum thirty minutes speed,
- when the standard on-board instrumentation indicates that the vehicle should be stopped,
- after 100 km.
- If the vehicle is not equipped with a pure electric mode, the electrical energy device/REESS shall be discharged by driving the vehicle (on the test track, on a chassis dynamometer, etc.) at any of the following conditions:
  - at a steady speed of 50 km/h until the fuel-consuming engine starts up,
  - if a vehicle cannot reach a steady speed of 50 km/h without the fuel-consuming engine starting up, the speed shall be reduced until it can run at a lower steady speed at which the fuel-consuming engine does not start up for a defined time or distance (to be determined by the test agency and the manufacturer to the satisfaction of the test agency ),
  - in accordance with the manufacturer's recommendation.

The fuel-consuming engine shall be stopped within ten seconds of being automatically started. By means of derogation if the manufacturer can prove to the test agency to the satisfaction of the test agency that the vehicle is physically not capable of achieving the thirty minutes speed the maximum fifteen minute speed may be used instead.

4.2.3. **Conditioning of the vehicle**

4.2.3.1. The test vehicle shall be preconditioned by conducting the applicable Type I test cycle in combination with the applicable gear-shifting prescriptions in clause 4.4.4.2.3 of chapter 2.



- 4.2.3.2. After this preconditioning and before testing, the vehicle shall be kept in a room in which the temperature remains relatively constant between 293.3K and 303.3K (20 °C and 30 °C). This conditioning shall be carried out for at least six hours and continue until the temperatures of the engine oil and coolant, if any, are within  $\pm 2\text{K}$  ( $\pm 2^{\circ}\text{C}$ ) of the temperature of the room, and the electrical energy device/REESS is fully charged as a result of the charging prescribed in clause 4.2.3.3 of this Appendix.
- 4.2.3.3. During soak, the electrical energy device/REESS shall be charged using the normal overnight charging procedure as defined in clause 3.2.2.4 of this Appendix
- 4.2.4. **Test procedure**
- 4.2.4.1. The vehicle shall be started up by the means provided for normal use by the driver. The first cycle starts on the initiation of the vehicle start-up procedure.
- 4.2.4.2. The test procedures defined in either clause 4.2.4.2.1. or 4.2.4.2.2 of this Appendix may be used
- 4.2.4.2.1. Sampling shall begin (BS) before or at the initiation of the vehicle start-up procedure and end on conclusion of the final idling period in the applicable Type I driving cycle (end of sampling (ES)).
- 4.2.4.2.2. Sampling shall begin (BS) before or at the initiation of the vehicle start-up procedure and continue over a number of repeat test cycles. It shall end on conclusion of the applicable Type I driving cycle during which the battery reached the minimum state of charge in accordance with the following procedure (end of sampling (ES)):
- 4.2.4.2.2.1 the electricity balance  $Q$  (Ah) is measured over each combined cycle, using the procedure in Appendix 1.2., and used to determine when the battery's minimum state of charge has been reached
- 4.2.4.2.2.2 The battery's minimum state of charge is considered to have been reached in combined cycle  $N$  if the electricity balance measured during combined cycle  $N + 1$  is not more than a 3 percent discharge, expressed as a percentage of the nominal capacity of the battery (in Ah) in its maximum state of charge, as declared by the manufacturer. At the manufacturer's request, additional test cycles may be run and their results included in the calculations in clauses 4.2.4.5. and 4.4. of this Appendix, provided that the electricity balance for each additional test cycle shows less discharge of the [battery than over the previous cycle.
- 4.2.4.2.2.3. between each pair of cycles, a hot soak period of up to ten minutes is allowed. The power train shall be switched off during this period.

- 4.2.4.3. The vehicle shall be driven using the applicable driving cycle and gear-shifting prescriptions as defined in appendix 8 to chapter 2.
- 4.2.4.4. The exhaust gases shall be analyzed according to chapter 2 in force at the time of approval of the vehicle.
- 4.2.4.5. The CO<sub>2</sub> emission and fuel consumption results on the test cycle for Condition A shall be recorded ( $m_1$  (g) and  $c_1$  (l) respectively). In the case of testing in accordance with clause 4.2.4.2.1 of this Appendix,  $m_1$  and  $c_1$  are the results of the single combined cycle run. In the case of testing in accordance with clause 4.2.4.2.2 of this Appendix  $m_1$  and  $c_1$  are the sums of the results of the N combined cycles run:

$$\text{Equation 17: } m_1 = \sum_1^N m_i$$

$$\text{Equation 18: } C_1 = \sum_1^N c_i$$

- 4.2.5. Within 30 minutes of the end of the cycle, the electrical energy device/REESS shall be charged in accordance with clause 3.2.2.4 of this Appendix.

The energy measurement equipment, placed between the mains socket and the vehicle charger, shall measure the energy charge  $e_1$  (Wh) delivered from the mains.

- 4.2.6 The electric energy consumption for Condition A shall be  $e_1$  (Wh).

### 4.3. **Condition B**

#### 4.3.1. **Conditioning of the vehicle**

- 4.3.1.1. The electrical energy device/REESS of the vehicle shall be discharged in accordance with clause 4.2.2.1 of this Appendix

At the manufacturer's request, conditioning in accordance with clause 4.2.3.1 of this Appendix may be carried out before electrical energy/power storage discharge.

- 4.3.1.2. Before testing, the vehicle shall be kept in a room in which the temperature shall remain relatively constant between 293.3K and 303.3K (20 °C and 30 °C). This conditioning shall be carried out for at least six hours and continue until the temperatures of the engine oil and coolant, if any, are within  $\pm 2^{\circ}\text{C}$  of the temperature of the room.

#### 4.3.2. **Test procedure**

- 4.3.2.1. The vehicle shall be started up by the means provided for normal use by the driver. The first cycle starts on the initiation of the vehicle start-up procedure.

- 4.3.2.2. Sampling shall begin (BS) before or at the initiation of the vehicle start-up procedure and end on conclusion of the final idling period in the applicable Type I driving cycle (end of sampling (ES)).
- 4.3.2.3. The vehicle shall be driven using the applicable driving cycle and gear-shifting prescriptions as defined in Appendix 8 to chapter 2.
- 4.3.2.4. The exhaust gases shall be analyzed in accordance with the provisions of chapter 2 in force at the time of approval of the vehicle.
- 4.3.2.5. The CO<sub>2</sub> emission and fuel consumption results on the test cycle(s) for Condition B shall be recorded ( $m_2$  (g) and  $c_2$  (l) respectively).
- 4.3.3. Within 30 minutes of the end of the cycle, the electrical energy device/REESS shall be charged in accordance with clause 3.2.2.4 of this Appendix
- The energy measurement equipment, placed between the mains socket and the vehicle charger, shall measure the energy charge  $e_2$  (Wh) delivered from the mains.
- 4.3.4. The electrical energy device/REESS of the vehicle shall be discharged in accordance with clause 4.2.2.1 of this Appendix
- 4.3.5. Within 30 minutes of the discharge, the electrical energy device/REESS shall be charged in accordance with clause 3.2.2.4 of this Appendix The energy measurement equipment, placed between the mains socket and the vehicle charger, shall measure the energy charge  $e_3$  (Wh) delivered from the mains.
- 4.3.6. The electric energy consumption  $e_4$  (Wh) for Condition B shall be:

$$\text{Equation 19: } e_4 = e_2 - e_3$$

4.4. **Test results**

4.4.1. **The CO<sub>2</sub> values shall be:**

$$\text{Equation 20: } M_1 = m_1 / D_{\text{test1}} \text{ (mg/km) and}$$

$$\text{Equation 21: } M_2 = m_2 / D_{\text{test2}} \text{ (mg/km)}$$

where:

$D_{\text{test1}}$  and  $D_{\text{test2}}$  = the actual distances driven in the tests performed under Conditions A (Clause 4.2.) and B (Clause 4.3.) respectively, and

$m_1$  and  $m_2$  = test results determined in points 4.2.4.5. and 4.3.2.5. of this Appendix respectively

4.4.2. **The weighted CO<sub>2</sub> values shall be calculated as follows:**

4.4.2.1. For testing in accordance with Clause 4.2.4.2.1 of this Appendix:

Equation 22:

$$M = (D_e * M_1 + D_{av} * M_2) / (D_e + D_{av})$$

where:

M = mass emission of CO<sub>2</sub> in grams per kilometre,

M<sub>1</sub> = mass emission of CO<sub>2</sub> in grams per kilometre with a fully charged electrical energy/power storage device,

M<sub>2</sub> = mass emission of CO<sub>2</sub> in grams per kilometre with an electrical energy/power storage device in minimum state of charge (maximum discharge of capacity),

D<sub>e</sub> = electric range of the vehicle determined according to the procedure described in Appendix 1.3., where the manufacturer shall provide the means for performing the measurement with the vehicle running in pure electric operating state,

D<sub>av</sub> = average distance between two battery recharges, D<sub>av</sub> =:

— 25 km for an L-category vehicle with an engine capacity of < 150 cm<sup>3</sup> ;

— 25 km for an L-category vehicle with an engine capacity of ≥ 150 cm<sup>3</sup> and v<sub>max</sub> < 130 km/h;

— 25 km for an L-category vehicle with an engine capacity of ≥ 150 cm<sup>3</sup> and v<sub>max</sub> ≥ 130 km/h.

4.4.2.2. For testing in accordance with Clause 4.2.4.2.2. of this Appendix:

Equation 23:

$$* M_1 + D_{av} * M_2) / (D_{ovc} + D_{av})$$

where:

M = mass emission of CO<sub>2</sub> in grams per kilometre,

M<sub>1</sub> = mass emission of CO<sub>2</sub> in grams per kilometre with a fully charged electrical energy/power storage device,

M<sub>2</sub> = mass emission of CO<sub>2</sub> in grams per kilometre with an electrical energy/power storage device in minimum state of charge (maximum discharge of capacity),

D<sub>ovc</sub> = OVC range according to the procedure described in Appendix 1.3.

D<sub>av</sub> = average distance between two battery recharges, D<sub>av</sub> =:

- 25 km for an L-category vehicle with an engine capacity of  $< 150 \text{ cm}^3$ ;
- 25 km for an L-category vehicle with an engine capacity of  $\geq 150 \text{ cm}^3$  and  $v_{\text{max}} < 130 \text{ km/h}$ ;
- 25 km for an L-category vehicle with an engine capacity of  $\geq 150 \text{ cm}^3$  and  $v_{\text{max}} \geq 130 \text{ km/h}$ .

4.4.3. **The fuel consumption values shall be:**

Equation 24:

$$C_1 = 100 * c_1 / D_{\text{test1}} \text{ and}$$

Equation 25:

$$C_2 = 100 * c_2 / D_{\text{test2}} \text{ (l/100 km)}$$

$D_{\text{test1}}$  and  $D_{\text{test2}}$  = the actual distances driven in the tests performed under Conditions A (Clause 4.2.) and B (Clause 4.3.) respectively.

$c_1$  and  $c_2$  = test results determined in points 4.2.4.5. and 4.3.2.5. of this Appendix respectively.

4.4.4. **The weighted fuel consumption values shall be calculated as follows:**

4.4.4.1. For testing in accordance with Clause 4.2.4.2.1. of this Appendix:

Equation 26:

$$C = (D_e * C_1 + D_{\text{av}} * C_2) / (D_e + D_{\text{av}})$$

$C$  = fuel consumption in l/100 km,

$C_1$  = fuel consumption in l/100 km with a fully charged electrical energy/power storage device,

$C_2$  = fuel consumption in l/100 km with an electrical energy/power storage device in minimum state of charge (maximum discharge of capacity),

$D_e$  = electric range of the vehicle determined according to the procedure described in Appendix 1.3., where the manufacturer shall provide the means for performing the measurement with the vehicle running in pure electric operating state,

$D_{\text{av}}$  = average distance between two battery recharges,  $D_{\text{av}} =$ :

- 25 km for an L-category vehicle with an engine capacity of  $< 150 \text{ cm}^3$ ;
- 25 km for an L-category vehicle with an engine capacity of  $\geq 150 \text{ cm}^3$  and  $v_{\text{max}} < 130 \text{ km/h}$ ;
- 25 km for an L-category vehicle with an engine capacity of  $\geq 150 \text{ cm}^3$  and  $v_{\text{max}} \geq 130 \text{ km/h}$ .

4.4.4.2. For testing in accordance with Clause 4.2.4.2.2.:

Equation 27:

$$C = (D_{ovc} * C_1 + D_{av} * C_2) / (D_{ovc} + D_{av})$$

where:

$C$  = fuel consumption in l/100 km,

$C_1$  = fuel consumption in l/100 km with a fully charged electrical energy/power storage device,

$C_2$  = fuel consumption in l/100 km with an electrical energy/power storage device in minimum state of charge (maximum discharge of capacity),

$D_{ovc}$  = OVC range according to the procedure described in Appendix 1.3.,

$D_{av}$  = average distance between two battery recharges,  $D_{av}$  =:

— 25 km for an L-category vehicle with an engine capacity of < 150 cm<sup>3</sup> ;

— 25 km for an L-category vehicle with an engine capacity of ≥ 150 cm<sup>3</sup> and  $v_{max} < 130$  km/h;

— 25 km for an L-category vehicle with an engine capacity of ≥ 150 cm<sup>3</sup> and  $v_{max} \geq 130$  km/h.

4.4.5. **The electric energy consumption values shall be:**

Equation 28:

$$E_1 = e_1 / D_{test1} \text{ and}$$

Equation 29:

$$E_4 = e_4 / D_{test2} \text{ (Wh/km)}$$

where:

$D_{test1}$  and  $D_{test2}$  = the actual distances driven in the tests performed under Conditions A (Clause 4.2.) and B (Clause 4.3.) respectively, and

$e_1$  and  $e_4$  = test results determined in points 4.2.6. and 4.3.6. of this Appendix respectively

4.4.6. The weighted electric energy consumption values shall be calculated as follows:

For testing in accordance with Clause 4.2.4.2.1. of this Appendix:

Equation 30:

$$E = (D_e * E_1 + D_{av} * E_4) / (D_e + D_{av})$$

where:

E = electric consumption Wh/km,

E<sub>1</sub> = electric consumption Wh/km with a fully charged electrical energy/power storage device,

E<sub>4</sub> = electric consumption Wh/km with an electrical energy/power storage device in minimum state of charge (maximum discharge of capacity),

D<sub>e</sub> = electric range of the vehicle determined according to the procedure described in Appendix 3.3., where the manufacturer shall provide the means for performing the measurement with the vehicle running in pure electric operating state,

D<sub>av</sub> = average distance between two battery recharges, D<sub>av</sub> =:

- 4 km for an L-category vehicle with an engine capacity of < 150 cm<sup>3</sup> ;
- 6 km for an L-category vehicle with an engine capacity of ≥ 150 cm<sup>3</sup> and v<sub>max</sub> < 130 km/h;
- 10 km for an L-category vehicle with an engine capacity of ≥ 150 cm<sup>3</sup> and v<sub>max</sub> ≥ 130 km/h.

4.4.6.2. For testing in accordance with Clause 4.2.4.2.2.:

Equation 31:

$$E = (D_{ovc} * E_1 + D_{av} * E_4) / (D_{ovc} + D_{av})$$

where:

E = electric consumption Wh/km,

E<sub>1</sub> = electric consumption Wh/km with a fully charged electrical energy/ power storage device,

E<sub>4</sub> = electric consumption Wh/km with an electrical energy/power storage device in minimum state of charge (maximum discharge of capacity),

D<sub>ovc</sub> = OVC range according to the procedure described in Appendix 1.3.of this Chapter,

D<sub>av</sub> = average distance between two battery recharges, D<sub>av</sub> =:

- 25 km for an L-category vehicle with an engine capacity of < 150 cm<sup>3</sup> ;
- 25 km for an L-category vehicle with an engine capacity of ≥ 150 cm<sup>3</sup> and v<sub>max</sub> < 130 km/h;
- 25 km for an L-category vehicle with an engine capacity of ≥ 150 cm<sup>3</sup> and v<sub>max</sub> ≥ 130 km/h.

## 5.0 NOT EXTERNALLY CHARGEABLE HYBRID ELECTRIC VEHICLE (NOVC HEV) WITHOUT AN OPERATING MODE SWITCH

5.1 The test vehicle shall be preconditioned by conducting the applicable Type I test cycle in combination with the applicable gear-shifting prescriptions in Clause 4.5.5. of Chapter 2.

5.1.1 Carbon dioxide (CO<sub>2</sub>) emissions and fuel consumption shall be determined separately for parts 1, 2 and 3, if applicable, of the applicable driving cycle in Appendix 6 to Chapter 2.

5.2 For preconditioning, at least two consecutive complete driving cycles shall be carried out without intermediate soak, using the applicable driving cycle and gear-shifting prescriptions set out in Clause 4.5.5. of Chapter 2.

### 5.3 Test results

5.3.1 The test results (fuel consumption  $C$  (l/100 km for liquid fuels or kg/100 km for gaseous fuels) and CO<sub>2</sub> - emission  $M$  (g/km)) of this test shall be corrected in line with the energy balance  $\Delta E_{\text{batt}}$  of the battery of the vehicle.

The corrected values  $C_0$  (l/100 km or kg/100 km) and  $M_0$  (g/km) shall correspond to a zero energy balance ( $\Delta E_{\text{batt}} = 0$ ) and shall be calculated using a correction coefficient determined by the manufacturer for storage systems other than electric batteries as follows:  $\Delta E_{\text{batt}}$  shall represent  $\Delta E_{\text{storage}}$ , the energy balance of the electric energy storage device.

5.3.1.1. The electricity balance  $Q$  (Ah), measured using the procedure in Appendix 3.2 to this Appendix of this Chapter, shall be used as a measure of the difference between the vehicle battery's energy content at the end of the cycle and that at the beginning of the cycle. The electricity balance is to be determined separately for the individual parts 1, 2 and 3, if applicable, of the Type I test cycle in Chapter 2.

5.3.2 **the uncorrected measured values  $C$  and  $M$  may be taken as the test results under the following conditions:**

- (a) the manufacturer can demonstrate to the satisfaction of the approval authority that there is no relation between the energy balance and fuel consumption,
- (b)  $\Delta E_{\text{batt}}$  always corresponds to a battery charging,
- (c)  $\Delta E_{\text{batt}}$  always corresponds to a battery discharging and  $\Delta E_{\text{batt}}$  is within 1% of the energy content of the consumed fuel (i.e. the total fuel consumption over one cycle).



The change in battery energy content  $\Delta E_{\text{batt}}$  shall be calculated from the measured electricity balance  $Q$  as follows:

*Equation 32:*

$$\Delta E_{\text{batt}} = \Delta \text{SOC}(\%) \cdot E_{\text{TEbatt}} \cong 0.0036 * |\Delta \text{Ah}| * V_{\text{batt}} = 0.0036 * Q * V_{\text{batt}} \text{ (MJ)}$$

where:

$E_{\text{TEbatt}}$  = the total energy storage capacity of the battery (MJ) and

$V_{\text{batt}}$  = the nominal battery voltage (V).

### 5.3.3 **Fuel consumption correction coefficient ( $K_{\text{fuel}}$ ) defined by the manufacturer**

5.3.3.1 The fuel consumption correction coefficient ( $K_{\text{fuel}}$ ) shall be determined from a set of  $n$  measurements, which shall contain at least one measurement with  $Q_i < 0$  and at least one with  $Q_j > 0$ .

If this second measurement cannot be taken on the applicable test Type I driving cycle used in this test, the technical service shall judge the statistical significance of the extrapolation necessary to determine the fuel consumption value at  $\Delta E_{\text{batt}} = 0$  to the satisfaction of the approval authority.

5.3.3.2 The fuel consumption correction coefficient ( $K_{\text{fuel}}$ ) shall be defined as:

*Equation 33:*

$$K_{\text{fuel}} = (n \sum Q_i C_i - \sum Q_i * \sum C_i) / (n * \sum Q_i^2 - (\sum Q_i)^2) \text{ (1/100km/Ah)}$$

where:

$C_i$  = fuel consumption measured during  $i$ -th manufacturer's test (l/100 km or kg/100km),

$Q_i$  = electricity balance measured during  $i$ -th manufacturer's test (Ah),

$n$  = number of data.

The fuel consumption correction coefficient shall be rounded to four significant figures (e.g. 0.xxxx or xx.xx). The technical service shall judge the statistical significance of the fuel consumption correction coefficient to the satisfaction of the approval authority

5.3.3.3 Separate fuel consumption correction coefficients shall be determined for the fuel consumption values measured over parts 1, 2 and 3, if applicable, of the Type I test cycle in Chapter 2.

### 5.3.4 **Fuel consumption at zero battery energy balance ( $C_0$ )**

5.3.4.1 Fuel consumption  $C_0$  at  $\Delta E_{\text{batt}} = 0$  is determined by the following equation:

*Equation 34:*

$$C_0 = C - K_{\text{fuel}} \cdot Q \text{ (l/100 km or kg/100 km)}$$

where:

$C$  = fuel consumption measured during test (l/100 km for liquid fuels and kg/100 km for gaseous fuels),

$Q$  = electricity balance measured during test (Ah).

5.3.4.2 Fuel consumption at zero battery energy balance shall be determined separately for the fuel consumption values measured over parts 1, 2 or 3, if applicable, of the Type I test cycle in Chapter 2.

### 5.3.5 **CO<sub>2</sub>-emission correction coefficient ( $K_{CO_2}$ ) defined by the manufacturer**

5.3.5.1 The CO<sub>2</sub> -emission correction coefficient ( $K_{CO_2}$ ) shall be determined as follows from a set of  $n$  measurements, which shall contain at least one measurement with  $Q_i < 0$  and at least one with  $Q_j > 0$ .

If this second measurement cannot be taken on the driving cycle used in this test, the technical service shall judge the statistical significance of the extrapolation necessary to determine the CO<sub>2</sub> -emission value at  $\Delta E_{\text{batt}} = 0$  to the satisfaction of the approval authority.

5.3.5.2 The CO<sub>2</sub> -emission correction coefficient ( $K_{CO_2}$ ) is defined as:

*Equation 35:*

$$K_{CO_2} = (n \cdot \sum Q_i M_i - \sum Q_i \cdot \sum M_i) / (n \cdot \sum Q_i^2 - (\sum Q_i)^2) \quad (\text{g/km/Ah})$$

where:

$M_i$  = CO<sub>2</sub> -emission measured during  $i$ -th manufacturer's test (g/km),

$Q_i$  = electricity balance during  $i$ -th manufacturer's test (Ah),

$N$  = number of data.

The CO<sub>2</sub> -emission correction coefficient shall be rounded to four significant figures (e.g. 0.xxxx or xx.xx). The technical service shall judge the statistical significance of the CO<sub>2</sub> -emission correction coefficient to the satisfaction of the approval authority

5.3.5.3 Separate CO<sub>2</sub> -emission correction coefficients shall be determined for the fuel consumption values measured over parts 1, 2 and 3, if applicable, of the type driving cycle in Chapter.

5.3.6 **CO<sub>2</sub> -emission at zero battery energy balance (M<sub>0</sub>)**

5.3.6.1 The CO<sub>2</sub> -emission M<sub>0</sub> at ΔE<sub>batt</sub> = 0 is determined by the following equation:

Equation 36:

$$M_0 = M - K_{CO_2} * Q \text{ (g/km)}$$

where:

C = fuel consumption measured during test (l/100 km for liquid fuels and kg/100 km for gaseous fuels),

Q = electricity balance measured during test (Ah).

5.3.6.3 CO<sub>2</sub> emissions at zero battery energy balance shall be determined separately for the CO<sub>2</sub> emission values measured over part 1, 2 and 3, if applicable, of the Type I test cycle set out in Appendix 6 to Chapter 2.

**6.0 NOT EXTERNALLY CHARGEABLE (NOT OVC HEV) WITH AN OPERATING MODE SWITCH**

6.1 These vehicles shall be tested in hybrid mode in accordance with Appendix 1, using the applicable driving cycle and gear-shifting prescriptions in Clause 4.5.5. of Chapter 2. If several hybrid modes are available, the test shall be carried out in the mode that is automatically set after the ignition key is turned on (normal mode).

6.1.1 Carbon dioxide (CO<sub>2</sub>) emissions and fuel consumption shall be determined separately for parts 1, 2 and 3 of the Type I test cycle in Chapter 2.

6.2 For preconditioning, at least two consecutive complete driving cycles shall be carried out without intermediate soak, using the applicable Type I test cycle and gear-shifting prescriptions in Chapter 2.

**6.3 Test results**

6.3.1 The fuel consumption C (l/100 km) and CO<sub>2</sub> -emission M (g/km)) results of this test shall be corrected in line with the energy balance ΔE<sub>batt</sub> of the battery of the vehicle.

The corrected values (C<sub>0</sub> (l/100 km for liquid fuels or kg/100 km for gaseous fuels) and M<sub>0</sub> (g/km)) shall correspond to a zero energy balance (ΔE<sub>batt</sub> = 0), and are to be calculated using a correction coefficient determined by the manufacturer as defined in 6.3.3 and 6.3.5.

For storage systems other than electric batteries, ΔE<sub>batt</sub> shall represent ΔE<sub>storage</sub>, the energy balance of the electric energy storage device.

6.3.1.1 The electricity balance  $Q$  (Ah), measured using the procedure in Appendix 1.2. of this Chapter, shall be used as a measure of the difference between the vehicle battery's energy content at the end of the cycle and that at the beginning of the cycle. The electricity balance is to be determined separately for parts 1, 2 and 3 of the applicable Type I test cycle set out in Chapter 2.

6.3.2 **The uncorrected measured values C and M may be taken as the test results under the following conditions:**

- (a) the manufacturer can prove that there is no relation between the energy balance and fuel consumption,
- (b)  $\Delta E_{\text{batt}}$  always corresponds to a battery charging,
- (c)  $\Delta E_{\text{batt}}$  always corresponds to a battery discharging and  $\Delta E_{\text{batt}}$  is within 1% of the energy content of the consumed fuel (i.e. the total fuel consumption over one cycle).

The change in battery energy content  $\Delta E_{\text{batt}}$  can be calculated from the measured electricity balance  $Q$  as follows:

Equation 37:

$$\Delta E_{\text{batt}} = \Delta \text{SOC}(\%) \cdot E_{\text{TEbatt}} = 0.0036 * |\Delta \text{Ah}| * V_{\text{batt}} = 0.0036 * Q * V_{\text{batt}} \text{ (MJ)}$$

where:

$E_{\text{TEbatt}}$  = the total energy storage capacity of the battery (MJ), and

$V_{\text{batt}}$  = the nominal battery voltage(V).

6.3.3 **Fuel consumption correction coefficient ( $K_{\text{fuel}}$ ) defined by the manufacturer**

6.3.3.1 The fuel consumption correction coefficient ( $K_{\text{fuel}}$ ) shall be determined from a set of  $n$  measurements, which shall contain at least one measurement with  $Q_i < 0$  and at least one with  $Q_j > 0$ .

If this second measurement cannot be taken on the driving cycle used in this test, the technical service shall judge the statistical significance of the extrapolation necessary to determine the fuel consumption value at  $\Delta E_{\text{batt}} = 0$  to the satisfaction of the approval authority.

6.3.3.2 The fuel consumption correction coefficient ( $K_{\text{fuel}}$ ) shall be defined as:

Equation 38:

$$K_{\text{fuel}} = \frac{(n * \sum Q_i C_i - \sum Q_i * \sum C_i) / (n * \sum Q_i^2 - \sum Q_i^2)}{\text{km/Ah}}$$

where:

$C_i$  = fuel consumption measured during i-th manufacturer's test (l/100 km for liquid fuels and kg/100 km for gaseous fuels)

$Q_i$  = electricity balance measured during i-th manufacturer's test (Ah)

$n$  = number of data

The fuel consumption correction coefficient shall be rounded to four significant figures (e.g. 0.xxxx or xx.xx). The statistical significance of the fuel consumption correction coefficient shall be judged by the technical service to the satisfaction of the approval authority.

6.3.3.3 Separate fuel consumption correction coefficients shall be determined for the fuel consumption values measured over parts 1, 2 and 3, if applicable, for the Type I test cycle set out in Chapter 2.

#### 6.3.4 **Fuel consumption at zero battery energy balance ( $C_0$ )**

6.3.4.1 The fuel consumption  $C_0$  at  $\Delta E_{\text{batt}} = 0$  is determined by the following equation:

Equation 39:

$$C_0 = C - K_{\text{fuel}} * Q \text{ (in l/100 km for liquid fuels and kg/100 km for gaseous fuels)}$$

where:

$C$  = fuel consumption measured during test (in l/100 km or kg/100 km)

$Q$  = electricity balance measured during test (Ah)

6.3.4.2 Fuel consumption at zero battery energy balance shall be determined separately for the fuel consumption values measured over parts 1, 2 and 3, if applicable, for the Type I test cycle set out in Chapter 2.

6.3.5 **CO<sub>2</sub> -emission correction coefficient ( $K_{CO_2}$ ) defined by the manufacturer**

- 6.3.5.1 The CO<sub>2</sub> -emission correction coefficient ( $K_{CO_2}$ ) shall be determined as follows from a set of n measurements. This set shall contain at least one measurement with  $Q_i < 0$  and one with  $Q_j > 0$ .

If this second measurement cannot be taken on the Type I test cycle used in this test, the technical service shall judge the statistical significance of the extrapolation necessary to determine the CO<sub>2</sub> -emission value at  $\Delta E_{batt} = 0$  to the satisfaction of the approval authority.

- 6.3.5.2 The CO<sub>2</sub> -emission correction coefficient ( $K_{CO_2}$ ) shall be defined as:

Equation 40:

$$K_{CO_2} = (n * \sum Q_i M_i - \sum Q_i * \sum M_i) / (n * \sum Q_i^2 - (\sum Q_i)^2)$$

in (g/km/Ah)

where:

$M_i$  = CO<sub>2</sub> -emission measured during i-th manufacturer's test (g/km)

$Q_i$  = electricity balance during i-th manufacturer's test (Ah)

$N$  = number of data

The CO<sub>2</sub> -emission correction coefficient shall be rounded to four significant figures (e.g. 0.xxxx or xx.xx). The statistical significance of the CO<sub>2</sub> -emission correction coefficient shall be judged by the technical service to the satisfaction of the approval authority.

- 6.3.5.3 Separate CO<sub>2</sub> -emission correction coefficients shall be determined for the fuel consumption values measured over parts 1, 2 and 3 of the applicable Type I test cycle

### 6.3.6 CO<sub>2</sub> emission at zero battery energy balance ( $M_0$ )

- 6.3.6.1 The CO<sub>2</sub> emission  $M_0$  at  $\Delta E_{batt} = 0$  is determined by the following equation:

Equation 41:

$$M_0 = M - K_{CO_2} * Q \text{ in (g/km)}$$

where:

$C$ : fuel consumption measured during test (l/100 km)

$Q$ : electricity balance measured during test (Ah)

- 6.3.6.2 CO<sub>2</sub> emission at zero battery energy balance shall be determined separately for the CO<sub>2</sub> -emission values measured over parts 1, 2 and 3, if applicable, for the Type I test cycle set out in Chapter 2.

**APPENDIX 1.1 TO CHAPTER 8**  
**ELECTRICAL ENERGY DEVICE /REESS STATE OF CHARGE (SOC)**  
**PROFILE FOR AN EXTERNALLY CHARGEABLE HYBRID ELECTRIC**  
**VEHICLE (OVC HEV) IN A TYPE VII TEST**

**1.0 STATE OF CHARGE (SOC) PROFILE FOR OVC HEV TYPE VII TEST**

The SOC profiles for OVC-HEVs tested under Conditions A and B of the test Type VII shall be:

**1.1. Condition A:**

- (1) initial state of charge of the electrical energy device /REESS;
- (2) Discharge in accordance with clause 3.2.1. or 4.2.2. of Appendix 1 of this Chapter;
- (3) Vehicle conditioning in accordance with clause 3.2.2.or 4.2.3. of Appendix 1 of this Chapter;
- (4) Charge during soak in accordance with clause 3.2.2.3. and 3.2.2.4. or 4.2.3.2. and 4.2.3.3. of Appendix 1 of this Chapter;
- (5) Test in accordance with clause 3.2.3. or 4.2.4. of Appendix 1 of this Chapter;
- (6) Charging in accordance with clause 3.2.4. or 4.2.5. of Appendix 1 of this Chapter.

**1.2. Condition B:**

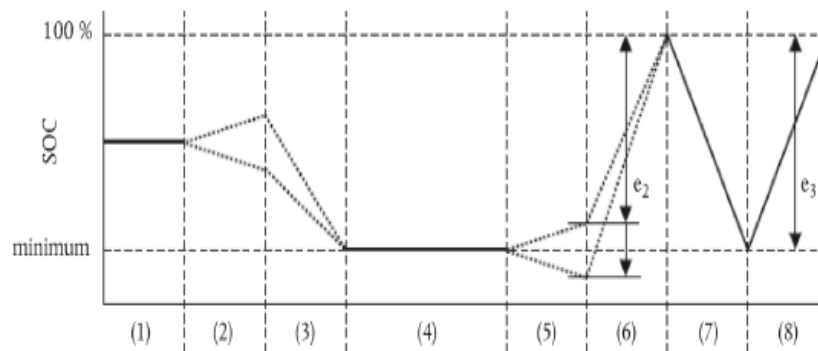

**Figure 2**

**Condition B of the Type VII test**

- (1) initial state of charge;
- (2) Vehicle conditioning in accordance with clause 3.3.1.1. or 4.3.1.1. (optional) of Appendix 1 of this Chapter;
- (3) Discharge in accordance with clause 3.3.1.1. or 4.3.1.1. of Appendix 1 of this Chapter;
- (4) Soak in accordance with clause 3.3.1.2. or 4.3.1.2. of Appendix 1 of this Chapter;
- (5) Test in accordance with clause 3.3.2. or 4.3.2. of Appendix 1 of this Chapter;
- (6) Charging in accordance with clause 3.3.3. or 4.3.3. of Appendix 1 of this Chapter;
- (7) Discharging in accordance with clause 3.3.4. or 4.3.4. of Appendix 1 of this Chapter;
- (8) Charging in accordance with clause 3.3.5. or 4.3.5. of Appendix 1 of this Chapter;

## APPENDIX 1.2 TO CHAPTER 8

### METHOD FOR MEASURING THE ELECTRICITY BALANCE OF THE BATTERY OF OVC AND NOVC HEV

#### 1.0 INTRODUCTION

1.1. This Appendix sets out the method and required instrumentation for measuring the electricity balance of Off- vehicle Charging Hybrid Electric Vehicles (OVC HEV) and Not-Off-vehicle Charging Hybrid Electric Vehicles (NOVC HEV). Measurement of the electricity balance is necessary:

(a) to determine when the battery's minimum state of charge has been reached during the test procedure in clauses 3.3. and 4.3. of Appendix 1 of this Chapter, and

(b) to adjust the fuel consumption and  $CO_2$  -emissions measurements in line with the change in battery energy content during the test, using the method in clauses 5.3.1.1. and 6.3.1.1. of Appendix 1 of this Chapter.

1.2. The method described in this Appendix shall be used by the manufacturer for taking the measurements to determine the correction factors  $K_{fuel}$  and  $K_{CO_2}$ , as defined in clauses 5.3.3.2., 5.3.5.2., 6.3.3.2., and 6.3.5.2. of Appendix 1 of this Chapter.

The test agency shall check whether these measurements have been taken in accordance with the procedure described in this Appendix.

1.3. The method described in this Appendix shall be used by the test agency for measuring the electricity balance  $Q$ , as defined in the relevant clauses of Appendix 3 of this Chapter.

#### 2.0 MEASUREMENT EQUIPMENT AND INSTRUMENTATION

2.1. During the tests described in clauses 3 to 6 of Appendix 1 of this Chapter, the battery current shall be measured using a current transducer of the clamp-on or the closed type. The current transducer (i.e. the current sensor without data acquisition equipment) shall have a minimum accuracy of 0.5 percent of the measured value or 0.1 percent of the maximum value of the scale.

Original equipment manufacturer diagnostic testers are not to be used for the purpose of this test.

2.1.1 The current transducer shall be fitted on one of the wires directly connected to the battery. To make it easier to measure the battery current with external equipment, the manufacturer shall integrate appropriate, safe and accessible connection points in the vehicle. If that is not feasible, the manufacturer is obliged to support the test agency by providing the means to connect a current transducer to the wires connected to the battery as described in clause 2.1 of this Appendix.



- 2.1.2. The output of the current transducer shall be sampled with a minimum sample frequency of 5 Hz. The measured current shall be integrated over time, yielding the measured value of Q, expressed in Ampere hours (Ah).
- 2.1.3. The temperature at the location of the sensor shall be measured and sampled with the same sample frequency as the current, so that this value can be used for possible compensation of the drift of current transducers and, if applicable, the voltage transducer used to convert the output of the current transducer.
- 2.2. The test agency shall be provided with a list of the instrumentation (manufacturer, model number, serial number) used by the manufacturer for determining the correction factors  $K_{fuel}$  and  $K_{CO_2}$  set out in Appendix 3 and the last calibration dates of the instruments, where applicable.

### **3.0 MEASUREMENT PROCEDURE**

- 3.1. Measurement of the battery current shall start at the beginning of the test and end immediately after the vehicle has driven the complete driving cycle.
- 3.2. Separate values of Q shall be logged over the parts (cold/warm or phase 1 and, if applicable, phases 2 and 3) of the Type I test cycle set out in Appendix 6 of Chapter 2.

## APPENDIX 1.3 TO CHAPTER 8

### METHOD OF MEASURING THE ELECTRIC RANGE OF VEHICLES POWERED BY BY A HYBRID ELECTRIC POWERTRAIN AND THE OVC RANGE OF VEHICLES POWERED BY A HYBRID ELECTRIC POWERTRAIN

#### 1.0 MEASUREMENT OF THE ELECTRIC RANGE

The following test method set out in clause 4 of this Appendix shall be used to measure the electric range, expressed in km, of vehicles powered by an electric range and OVC range of vehicles powered by a hybrid electric powertrain with off-vehicle charging (OVC HEV) as defined in Appendix 1 of this Chapter.

#### 2.0 PARAMETERS, UNITS AND ACCURACY OF MEASUREMENTS

Parameters, units and accuracy of measurements shall be as follows:

**Table 1**

**Parameters, units and accuracy of measurements**

Parameter	Unit	Accuracy	Resolution
Time	s	$\pm 0.1$ s	0.1s
Distance	m	$\pm 0.1$ percent	1 m
Temperature	$^{\circ}\text{C}$	$\pm 1$ $^{\circ}\text{C}$	1 $^{\circ}\text{C}$
Speed	km/h	$\pm 1$ percent	0.2 km/h
Mass	kg	$\pm 0.5$ percent	1 kg

#### 3.0 TEST CONDITIONS

##### 3.1. Condition of the vehicle

- 3.1.1. The vehicle tyres shall be inflated to the pressure specified by the vehicle manufacturer when the tyres are at the ambient temperature.
- 3.1.2. The viscosity of the oils for the mechanical moving parts shall conform to the vehicle manufacturer's specifications.
- 3.1.3. The lighting and signalling and auxiliary devices shall be off, except those required for the testing and usual daytime operation of the vehicle.
- 3.1.4. All energy storage systems for other than traction purposes (electric, hydraulic, pneumatic, etc.) shall be charged to their maximum level as specified by the manufacturer.

3.1.5. If the batteries are operated above the ambient temperature, the operator shall follow the procedure recommended by the vehicle manufacturer in order to keep the battery temperature in the normal operating range. The manufacturer shall be in a position to attest that the thermal management system of the battery is neither disabled nor reduced.

3.1.6. The vehicle shall have travelled at least 300 km in the seven days before the test with the batteries installed for the test.

3.2. **Climatic conditions**

For testing performed outdoors, the ambient temperature shall be between (5 °C and 32 °C).

The indoor testing shall be performed at a temperature of between (2 °C and 30 °C).

**4.0 OPERATION MODES**

The test method includes the following steps:

- a) initial charge of the battery;
- b) Application of the cycle and measurement of the electric range.

If the vehicle shall move between the steps, it shall be pushed to the next test area (without regenerative recharging).

4.1. **Initial charge of the battery**

Charging the battery consists of the following procedure:

4.1.1. The ‘initial charge’ of the battery means the first charge of the battery, on reception of the vehicle. Where several combined tests or measurements are carried out consecutively, the first charge shall be an ‘initial charge’ and the subsequent charges may follow the ‘normal overnight charge’ procedure set out in 3.2.2.4. of Appendix 1 of this Chapter.

4.1.2. **Discharge of the battery**

4.1.2.2. For externally chargeable hybrid electric vehicles (OVC HEV) without an operating mode switch as defined in Appendix 1 of this Chapter:

4.1.2.2.1. The manufacturer shall provide the means for taking the measurement with the vehicle running in pure electric operating state.

4.1.2.2.2. The procedure shall start with the discharge of the electrical energy device /REESS of the vehicle while driving (on the test track, on a chassis dynamometer, etc.) in any of the following conditions:

- at a steady speed of 50 km/h until the fuel-consuming engine of the HEV starts up;
- if a vehicle cannot reach a steady speed of 50 km/h without the fuel-consuming engine starting up, the speed shall be reduced until it can run at a lower steady speed at which the fuel-consuming engine does not start up for a defined time or distance (to be determined by the test agency and the manufacturer);
- In accordance with the manufacturer’s recommendation.

The fuel-consuming engine shall be stopped within ten seconds of being automatically started.

4.1.2.3. For externally chargeable hybrid electric vehicles (OVC HEV) with an operating mode switch as defined in Appendix 3 of this Chapter:

4.1.2.3.1. If the mode switch does not have a pure electric position, the manufacturer shall provide the means for taking the measurement with the vehicle running in pure electric operating state.

4.1.2.3.2. The procedure shall start with the discharge of the electrical energy device /REESS of the vehicle while driving with the switch in pure electric position (on the test track, on a chassis dynamometer, etc.) at a steady speed of 70 percent  $\pm$  5 percent of the maximum design vehicle speed of the vehicle in pure electric mode.

4.1.2.3.3. Discharging shall stop in any of the following conditions:

- when the vehicle is unable to run at 65 percent of the maximum thirty minutes speed;
- when the standard on-board instrumentation indicates that the vehicle should be stopped;
- after 100 km.

By means of derogation if the manufacturer can prove to the test agency to the satisfaction of the approval authority that the vehicle is physically not capable of achieving the thirty minutes speed the maximum fifteen minute speed may be used instead.

4.1.2.3.4. If the vehicle is not equipped with a pure electric operating state, the electrical energy device /REESS shall be discharged by driving the vehicle (on the test track, on a chassis dynamometer, etc.):

- at a steady speed of 50 km/h until the fuel-consuming engine of the HEV starts up; or

— if a vehicle cannot reach a steady speed of 50 km/h without the fuel-consuming engine starting up, the speed shall be reduced until it can run at a lower steady speed at which the fuel-consuming engine does not start up for a defined time or distance (to be determined by the technical service and the manufacturer to the satisfaction of the approval authority); or

— in accordance with the manufacturer's recommendation.

The fuel-consuming engine shall be stopped within ten seconds of being automatically started.

#### 4.1.3. **Normal overnight charge**

For an OVC HEV, the battery shall be charged according to the normal overnight charge procedure as described in clause 3.2.2.4. of Appendix 1 of this Chapter.

### 4.2. **Application of the cycle and measurement of the range**

#### 4.2.1 **Reserved**

#### 4.2.2. **For hybrid electric vehicles:**

4.2.2.1.1. The applicable Type I test cycle and accompanying gearshift arrangements, as set out in clause 4.5.5. of Chapter 2 shall be carried out on a chassis dynamometer adjusted as described in Chapter 2, until the test criteria are met.

4.2.2.1.2. To measure the electric range, the test criteria shall be deemed as having been met when the vehicle is unable to meet the target curve up to 50 km/h, or when the standard on-board instrumentation indicates that the vehicle should be stopped, or when the battery has reached its minimum state of charge. The vehicle shall then be slowed to 5 km/h without braking by releasing the accelerator pedal, and then stopped by braking.

4.2.2.1.3. At speeds of over 50 km/h, when the vehicle does not reach the acceleration or speed required for the test cycle, the accelerator pedal shall remain fully depressed until the reference curve has been reached again.

4.2.2.1.4. Up to three interruptions, of no more than 15 minutes in total, are permitted between test sequences.

4.2.2.1.5. The distance covered in km using the electrical motor only ( $D_e$ ) is the electric range of the hybrid electric vehicle. It shall be rounded to the nearest whole number. Where the vehicle operates both in electric and in hybrid mode during the test, the periods of electric-only operation will be determined by measuring current to the injectors or ignition.

- 4.2.2.2. Determining the OVC range of a hybrid electric vehicle
  - 4.2.2.2.1. The applicable Type I test cycle and accompanying gearshift arrangements, as set out in clause 4.4.5. of Chapter 2, shall be carried out on a chassis dynamometer adjusted as described in Chapter 2, until the test criteria are met.
  - 4.2.2.2.2. To measure the OVC range  $D_{OVC}$ , the test criteria shall be deemed as having been met when the battery has reached its minimum state of charge according to the criteria in clauses 3.2.3.2.2.2. or 4.2.4.2.2.2. of Appendix 1 of this Chapter. Driving shall be continued until the final idling period in the Type I test cycle has been completed.
  - 4.2.2.2.3. Up to three interruptions, of no more than fifteen minutes in total, are permitted between test sequences.
  - 4.2.2.2.4. The total distance driven in km, rounded to the nearest whole number, shall be the OVC range of the hybrid electric vehicle.
- 4.2.2.3. At speeds of over 50 km/h, when the vehicle does not reach the acceleration or speed required for the test cycle, the accelerator pedal shall remain fully depressed, or the accelerator handle shall be turned fully, until the reference curve has been reached again.
- 4.2.2.4. Up to three interruptions, of no more than 15 minutes in total, are permitted between test sequences.
- 4.2.2.5. The distance covered in km ( $D_{OVC}$ ) is the electric range of the hybrid electric vehicle. It shall be rounded to the nearest whole number.

<b>ANNEXURE I</b>	
<b>COMPOSITION OF AISC PANEL*</b>	
<b>NAME</b>	
Mr. Dinesh Tyagi	Convener – Director, ICAT International Centre for Automotive Technology, Manesar
<b>MEMBERS</b>	<b>REPRESENTING</b>
Ms. Pamela Tikku	International Centre for Automotive Technology, Manesar
Ms. Vijayanta Ahuja	International Centre for Automotive Technology, Manesar
Mr. Vikas Sadan	International Centre for Automotive Technology, Manesar
Ms. Sita Kumari	International Centre for Automotive Technology, Manesar
Mr. Deepak Joshi	International Centre for Automotive Technology, Manesar
Ms. S.S. Bakle	Automotive Research Association of India
Mr. A. S. Bhale	Automotive Research Association of India
Mr. S.S. Sattigeri	Central Institute of Road Transport
Mr. M. K. Chaudhari	Central Institute of Road Transport
Mr. Nilesh Tagad	Central Institute of Road Transport
Mr. Suraj Agarwal	Honda Motor cycle and Scooter India Ltd.
Mr. T. M Balaraman	Hero Moto Corp ltd.
Mr. Iranna K.G.	Indian Institute of Petroleum
Representative of	Society of Indian Automobile Manufacturers

**ANNEXURE II**  
(See Introduction)

**COMMITTEE COMPOSITION\***  
**Automotive Industry Standards Committee**

<b>Chairperson</b>	
Mrs. Rashmi Urdhwareshe	Director The Automotive Research Association of India, Pune
<b>Members</b>	<b>Representing</b>
Representative from	Ministry of Road Transport and Highways (Dept. of Road Transport and Highways), New Delhi
Representative from	Ministry of Heavy Industries and Public Enterprises (Department of Heavy Industry), New Delhi
Shri S. M. Ahuja	Office of the Development Commissioner, MSME, Ministry of Micro, Small and Medium Enterprises, New Delhi
Shri Shrikant R. Marathe	Former Chairman, AISC
Shri R.R. Singh	Bureau of Indian Standards, New Delhi
Director	Central Institute of Road Transport, Pune
Director	Global Automotive Research Centre
Director	International Centre for Automotive Technology, Manesar
Director	Indian Institute of Petroleum, Dehra Dun
Director	Vehicles Research and Development Establishment, Ahmednagar
Director	Indian Rubber Manufacturers Research Association
Representatives from	Society of Indian Automobile Manufacturers
Shri R. P. Vasudevan	Tractor Manufacturers Association, New Delhi
Shri Uday Harite	Automotive Components Manufacturers Association of India, New Delhi

Member Secretary  
Shri Vikram Tandon  
Dy. General Manager  
The Automotive Research Association of India, Pune

\* At the time of approval of this Automotive Industry Standard (AIS)