

**AMENDMENT NO. 6 (02 / 2019)**

**To**

**AIS-029 / 2004**

**Survival Space for the Protection of the Occupants  
of the Cab of a Commercial Vehicle**

**1. Page 2/15, clause 5.2,**

Substitute the following text for existing text:

“5.2 It shall be subjected, at the Vehicle Manufacturer’s/ Truck body builder’s choice, either to all the tests specified in para. 7 of this standard or only to tests A and B. One, two or three cabs, at the Vehicle Manufacturer’s/ Truck body builder’s choice, shall be used for this purpose.

However, vehicle of category N1 and L7N, which meets the frontal impact requirements of Paragraph 5.1 of AIS-096 or Clause No. 7 of IS: 11939, vehicles of category N1, derived from M1 approved to AIS-098 or IS: 11939 or AIS-096, and vehicles of category L7N, derived from L7M approved to AIS-096 may be considered to comply with the requirements of frontal impact (Test A).”

**Note:** “Vehicles of category N1 derived from M1” means those vehicles of N1 category which, forward of the A-pillars, have the same general structure and shape as a pre-existing M1 category vehicle.

Vehicles of category L7N derived from L7M” means those vehicles of L7N category which, forward of the A-pillars, have the same general structure and shape as a pre-existing L7M category vehicle.

PRINTED BY  
THE AUTOMOTIVE RESEARCH ASSOCIATION OF INDIA  
P. B. NO. 832, PUNE 411 004  
ON BEHALF OF  
AUTOMOTIVE INDUSTRY STANDARDS COMMITTEE  
UNDER  
CENTRAL MOTOR VEHICLES RULES - TECHNICAL STANDING COMMITTEE  
SET-UP BY  
MINISTRY OF ROAD TRANSPORT & HIGHWAYS  
(DEPARTMENT OF ROAD TRANSPORT & HIGHWAYS)  
GOVERNMENT OF INDIA

6<sup>th</sup> February 2019

**AMENDMENT NO. 5 13 April 2017**

**To**

**AIS-029 / 2004**

**Survival Space for the Protection of the Occupants  
of the Cab of a Commercial Vehicle**

**1. Page 2/15, Clause 5.2 Requirements,**

**Add new paragraph & a note at the end of existing clause No. 5.2 as follows:**

“However, vehicle of category N1, which meets the frontal impact requirements of Paragraph 5.1 of AIS-096 or Clause No. 7 of IS: 11939, and vehicles of category N1, derived from M1 approved to AIS 098 or IS: 11939 or AIS 096, may be considered to comply with the requirements of frontal impact (Test A).”

**Note:** “Vehicles of category N1 derived from M1” means those vehicles of N1 category which, forward of the A-pillars, have the same general structure and shape as a pre-existing M1 category vehicle.

**2. Page 2/15, After Clause No 5.2, add new clause 5.3 & a note as below:**

5.3 Frontal impact (Test A) shall only be conducted on “Cab-over Engine vehicles” or “Forward control vehicles”.

**Note:** “Cab-over engine vehicle” or “Forward control vehicles” means a vehicle where more than half of the engine length is rearward of the foremost point of the windshield base and the steering wheel hub is in the forward quarter of the vehicle length.

**3. Page 2/15 & 3/15, Clause 5.3, 5.3.1, 5.3.2, 5.4, 5.4.1, 5.4.2 & 5.5**

Clauses 5.3, 5.3.1, 5.3.2, 5.4, 5.4.1, 5.4.2 & 5.5 (former) rename as Clause 5.4, 5.4.1, 5.4.2, 5.5, 5.5.1, 5.5.2 & 5.6 respectively.

PRINTED BY  
THE AUTOMOTIVE RESEARCH ASSOCIATION OF INDIA  
P. B. NO. 832, PUNE 411 004  
ON BEHALF OF  
AUTOMOTIVE INDUSTRY STANDARDS COMMITTEE  
UNDER  
CENTRAL MOTOR VEHICLES RULES - TECHNICAL STANDING COMMITTEE  
SET-UP BY  
MINISTRY OF ROAD TRANSPORT & HIGHWAYS  
(DEPARTMENT OF ROAD TRANSPORT & HIGHWAYS)  
GOVERNMENT OF INDIA

13 April 2017

**AMENDMENT NO. 4 15 June 2015**

**To**

**AIS-029 / 2004**

**Survival Space for the Protection of the Occupants  
of the Cab of a Commercial Vehicle**

**1. Page No.1/15, clause 1:**

Substitute the following text for existing text :

“1. This Automotive Industry Standard specifies the requirements of survival space for the protection of occupants of the Cab of a Commercial vehicle of category N as defined in IS: 14272 (Part 1):1995 and L7-N which are intended for the carriage of goods. It does not apply to agricultural tractors and machinery and construction equipment vehicles.”

PRINTED BY  
THE AUTOMOTIVE RESEARCH ASSOCIATION OF INDIA  
P. B. NO. 832, PUNE 411 004

ON BEHALF OF  
AUTOMOTIVE INDUSTRY STANDARDS COMMITTEE

UNDER  
CENTRAL MOTOR VEHICLES RULES - TECHNICAL STANDING COMMITTEE

SET-UP BY  
MINISTRY OF ROAD TRANSPORT & HIGHWAYS  
(DEPARTMENT OF ROAD TRANSPORT & HIGHWAYS)  
GOVERNMENT OF INDIA

15 June 2015

**AMENDMENT NO. 3 16 May 2014**  
**TO**  
**AIS – 029**  
**Survival Space for the Protection of the Occupants**  
**of the Cab of a Commercial Vehicle**

1.0 Page No. 9/15, Annex: 2, Figure (Fiftieth - Percentile Male Body)

Substitute following figure for existing figure

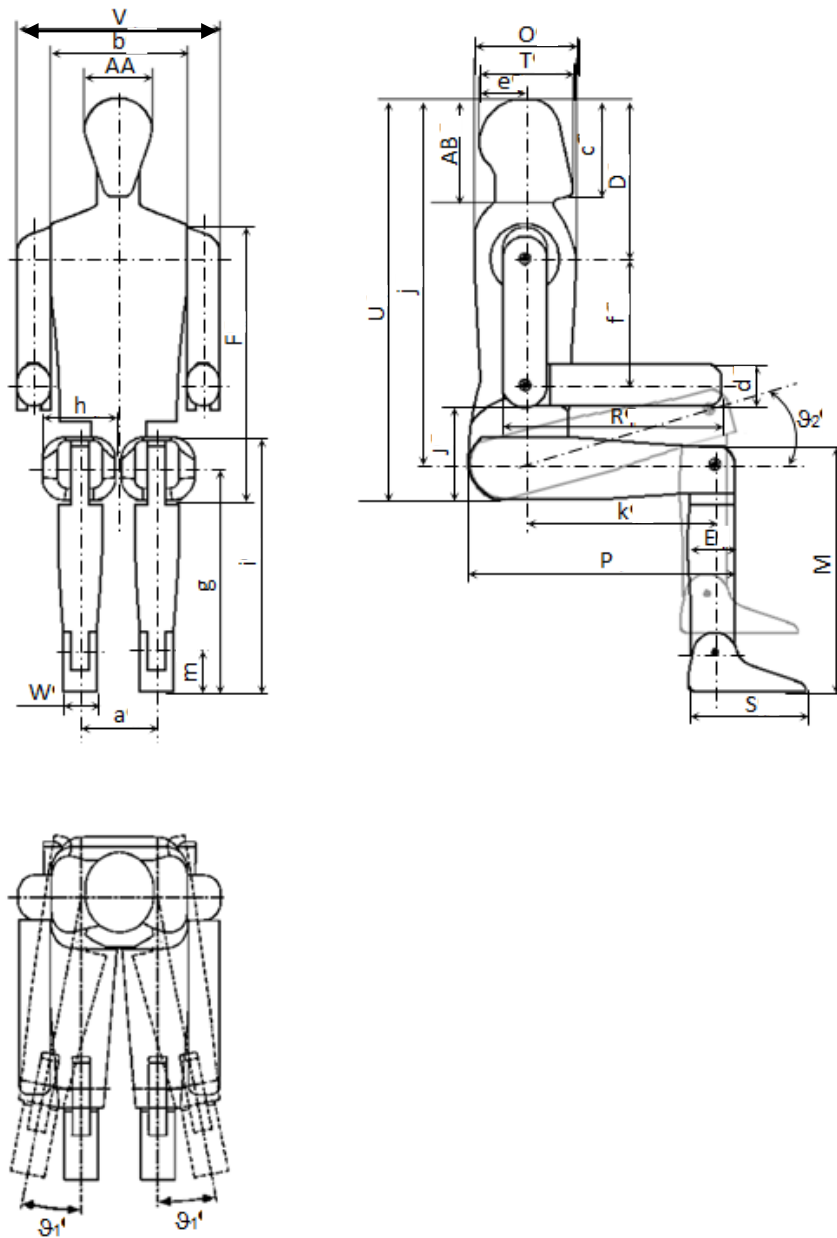

**(Fiftieth –percentile Male Body)**

2.0 Page No. 10/15, Annex:2,Dimensions of Manikin :

Add two rows “ $\theta_1$ ” and “ $\theta_2$ ” in the dimension of Manikin as follows

$\theta_1$	Lateral rotation of legs	0 to 20
$\theta_2$	Upward rotation of legs	0 to 45

PRINTED BY

THE AUTOMOTIVE RESEARCH ASSOCIATION OF INDIA  
P. B. NO. 832, PUNE 411 004  
ON BEHALF OF

AUTOMOTIVE INDUSTRY STANDARDS COMMITTEE  
UNDER

CENTRAL MOTOR VEHICLES RULES - TECHNICAL STANDING COMMITTEE  
SET-UP BY

MINISTRY OF ROAD TRANSPORT & HIGHWAYS  
(DEPARTMENT OF ROAD TRANSPORT & HIGHWAYS)  
GOVERNMENT OF INDIA

16 May 2014

**AMENDMENT NO. 2**

**TO  
AIS-029**

**Survival Space for the Protection of the Occupants of the  
Cab of a Commercial Vehicle**

**1. Page No. 2 and 3, Clause 5.3.1:**

Substitute following text for the existing text :

“ **5.3.1** After undergoing each of the tests referred to in paragraph 5.2 above, the cab of the vehicle shall exhibit a survival space allowing accommodation of the manikin defined in Annex 2, on the seat, when the latter is in its median position, without contact between the manikin and non-resilient parts. To facilitate installation, the manikin may be inserted in dismantled form and assembled in the cab.

For this purpose, the seat shall be adjusted to its most rearward position and the manikin completely assembled and so placed that its H point coincides with the R point. The R point shall be determined as per IS: 13749:1993. The seat shall then be moved forward to its median position for the assessment of the survival space. As an alternative to the test manikin defined in Annex 2, a fiftieth percentile Hybrid II or III male dummy, with or without measuring instrumentation may be used.”

PRINTED BY  
THE AUTOMOTIVE RESEARCH ASSOCIATION OF INDIA  
P. B. NO. 832, PUNE 411 004

ON BEHALF OF  
AUTOMOTIVE INDUSTRY STANDARDS COMMITTEE

UNDER  
CENTRAL MOTOR VEHICLE RULES - TECHNICAL STANDING COMMITTEE

SET-UP BY  
MINISTRY OF ROAD TRANSPORT & HIGHWAYS  
(DEPARTMENT OF ROAD TRANSPORT & HIGHWAYS)  
GOVERNMENT OF INDIA

September 2012

**AMENDMENT NO. 1**  
**TO**  
**AIS - 029**  
**Survival Space for the Protection of the Occupants**  
**of the Cab of a Commercial Vehicle**

1.0 Page No. 9/15, Annex : 2, Figure (Fiftieth - Percentile Male Body)  
Substitute figure given below for existing figure.

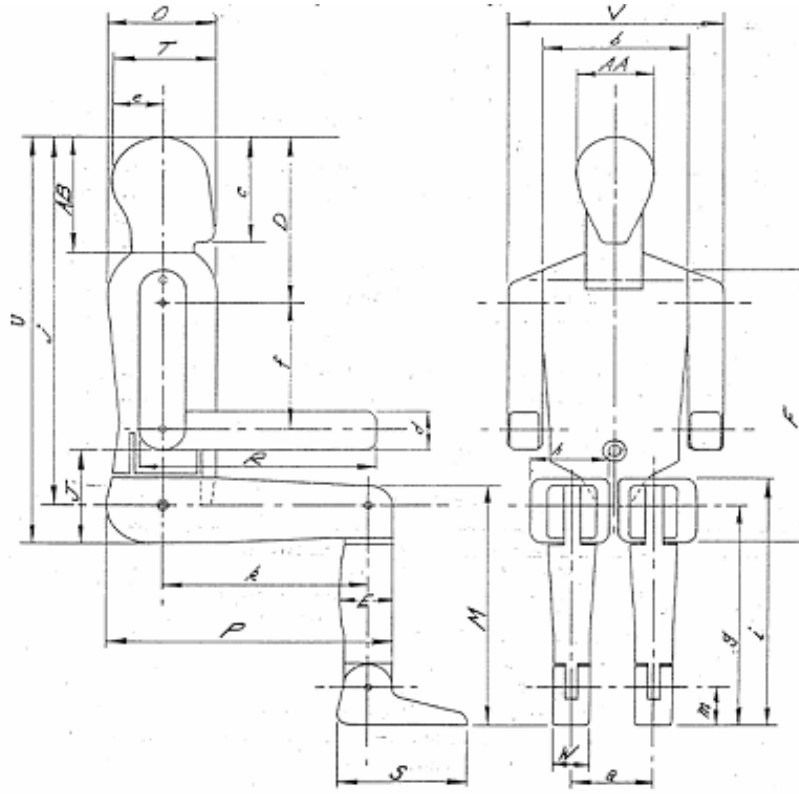

PRINTED BY  
THE AUTOMOTIVE RESEARCH ASSOCIATION OF INDIA  
P. B. NO. 832, PUNE 411 004  
ON BEHALF OF  
AUTOMOTIVE INDUSTRY STANDARDS COMMITTEE  
UNDER  
CENTRAL MOTOR VEHICLE RULES - TECHNICAL STANDING COMMITTEE  
SET-UP BY  
MINISTRY OF SHIPPING, ROAD TRANSPORT & HIGHWAYS  
(DEPARTMENT OF ROAD TRANSPORT & HIGHWAYS)  
GOVERNMENT OF INDIA  
February 2007

**AUTOMOTIVE INDUSTRY STANDARD**

**Survival Space for the Protection of  
the Occupants of the Cab of  
a Commercial Vehicle**

PRINTED BY

THE AUTOMOTIVE RESEARCH ASSOCIATION OF INDIA  
P. B. NO. 832. PUNE 411 004

ON BEHALF OF  
AUTOMOTIVE INDUSTRY STANDARDS COMMITTEE

UNDER  
CENTRAL MOTOR VEHICLE RULES - TECHNICAL STANDING COMMITTEE

SET-UP BY  
MINISTRY OF ROAD TRANSPORT & HIGHWAYS  
GOVERNMENT OF INDIA

December 2004



Status chart of the Standard to be used by the purchaser  
for updating the record

<b>Sr. No.</b>	<b>Corr-igenda.</b>	<b>Amend-ment</b>	<b>Revision</b>	<b>Date</b>	<b>Remark</b>	<b>Misc.</b>

**General remarks:**

**INTRODUCTION**

The Government of India felt the need for a permanent agency to expedite the publication of standards and development of test facilities in parallel when the work on the preparation of the standards is going on, as the development of improved safety critical parts can be undertaken only after the publication of the standard and commissioning of test facilities. To this end, the Ministry of Surface Transport (MOST) has constituted a permanent Automotive Industry Standards Committee (AISC) vide order No.RT-11028/11/97-MVL dated September 15, 1997. The standards prepared by AISC will be approved by the permanent CMVR Technical Standing Committee (CTSC). After approval, the Automotive Research Association of India, (ARAI), Pune, being the Secretariat of the AIS Committee, has published this standard. For better dissemination of this information ARAI may publish this document on their Web site.

The cab of the vehicle shall be so designed and attached to the vehicle as to eliminate to the greatest possible extent the risk of injury to the occupants in the event of an accident. This standard specifies the requirement of survival space for the protection of occupants of the cab of a commercial vehicle of category N. This standard forms a part of the Truck Body Code.

While preparing this AIS considerable assistance is derived from ECE R 29 (Rev 01, Amendment 1 of 02 series of amendments : date of entry into force : 27 February 1999) Uniform provisions concerning the Approval of Vehicles with regard to the Protection of the Occupants of the Cab of a Commercial Vehicle.

The Automotive Industry Standards Committee responsible for preparation of this standard is given in Annexure: 6 .

## Survival Space for the Protection of the Occupants of the Cab of a Commercial Vehicle

### 1. SCOPE

This Automotive Industry Standard specifies the requirements of survival space for the protection of occupants of the Cab of a Commercial vehicle of category N as defined in IS: 14272 (Part 1) : 1995 which are intended for the carriage of goods. It does not apply to agricultural tractors and machinery and construction equipment vehicles.

### 2. REFERENCES

IS: 14272 (Part 1)- 1995	Automotive Vehicles - Types - Terminology, Part 1: Three and Four Wheelers
IS: 13749-1993	Automotive Vehicles - Determination of H point – Method of Test
IS 9211-1979	Denominations and definitions of weights of road vehicles
IS: 11849- 1986	Method of determination of Centre of Gravity of automotive vehicles

### 3. DEFINITIONS

For the purpose of this standard:

- 3.1 “**Approval of a vehicle**” means the approval of a vehicle type pursuant to the requirements of this Standard, with regard to the protection of the occupants of the cab of a commercial vehicle in the event of head-on impact, of overturning, or of shifting of the load;
- 3.2 “**Vehicle type**” means a category of power-driven vehicles which do not differ in such essential respects as: the dimensions, shapes and materials of the components of the vehicle cab; or the manner of attachment of the cab to the chassis frame;
- 3.3 “**Transverse plane**” means a vertical plane perpendicular to the median longitudinal plane of the vehicle;
- 3.4 “**Longitudinal plane**” means a plane parallel to the median longitudinal plane of the vehicle.

#### **4. APPLICATION FOR APPROVAL**

- 4.1 The application for approval of a vehicle type with regard to the protection of the occupants of the cab of a commercial vehicle shall be submitted by the Vehicle Manufacturer/ Truck body builder to Test Agency.
- 4.2 It shall be accompanied by the drawings of vehicle, showing the position of the cab on the vehicle and the manner of its attachment, and by sufficiently detailed drawings relating to the structure of the cab, all the said drawings being submitted by the Vehicle Manufacturer/ Truck body builder.
- 4.3 Drawings of the vehicle and those parts of its interior arrangement which have an influence on the strength of cab or on the survival space.
- 4.4 Particulars of:
  - 4.4.1 The unladen kerb weight as defined in clause 3.4 of IS: 9211 - 1979
  - 4.4.2 The gross vehicle weight and its distribution on the axles
  - 4.4.3 The position of the center of gravity of unladen vehicle in the longitudinal, transverse and vertical directions as defined in IS: 11849 - 1986.
  - 4.4.4 Either a complete vehicle or a complete cab representative of the type to be approved shall be submitted to the Test Agency responsible for conducting the approval test unless the approval is to be conducted by means of calculation, in which case the calculation shall be submitted to the Test Agency.

#### **5. REQUIREMENTS**

- 5.1 The cab of the vehicle shall be so designed and so attached to the vehicle as to eliminate to the greatest possible extent the risk of injury to the occupants in the event of an accident.
- 5.2 It shall be subjected, at the Vehicle Manufacturer's/ Truck body builder's choice, either to all the tests specified in para. 7 of this standard or only to tests A and B. One, two or three cabs, at the Vehicle Manufacturer's/ Truck body builder's choice, shall be used for this purpose.

##### **5.3 Survival Space Required after the Test or Tests**

- 5.3.1 After undergoing each of the tests referred to in paragraph 5.2 above, the cab of the vehicle shall exhibit a survival space allowing accommodation of the manikin defined in Annex 2, on the seat, when the latter is in its median position, without contact between the manikin and non-resilient parts. To facilitate installation, the manikin may be inserted in dismantled form and assembled in the cab.

For this purpose, the seat shall be adjusted to its most rearward position and the manikin completely assembled and so placed that its H point coincides with the R point. The R point shall be determined as per IS: 13749:1993. The seat shall then be moved forward to its median position for the assessment of the survival space.

- 5.3.2 The space so defined shall be verified for every seat provided by the Vehicle Manufacturer / Truck body builder (See Annex 4).

#### **5.4 Other Conditions**

- 5.4.1 During the tests the components by which the cab is secured to the chassis frame may be distorted or broken, provided that the cab remains attached to the chassis frame.
- 5.4.2 None of the doors shall open during the tests, but the doors shall not be required to open after testing.
- 5.5 Tests B and C need not be carried out if the Vehicle Manufacturer/Truck body builder can show by calculations of the strength of the component parts of the cab or by other means that the roof or rear wall will not undergo deformation dangerous to the occupants (penetration into the survival space) if subjected to the conditions of tests B and C.

### **6. MODIFICATIONS AND EXTENSION OF APPROVAL OF THE VEHICLE TYPE**

- 6.1 Every modification of the vehicle type shall be notified to the Test Agency, which approved the vehicle type. The Test Agency may then either:
- 6.1.1 consider that the modifications made are unlikely to have an appreciable adverse effect, and that in any case the vehicle still meets the requirements; or
- 6.1.2 require a further test report by conducting the tests.
- 6.1.3 The criteria for extension of approval (CEA) are given in Annex 5

### **7. TEST PROCEDURE**

#### **7.1 DOORS**

Before the test the doors of the cab shall be closed but not locked.

#### **7.2 ENGINE**

For test A the engine, or a model equivalent thereto in mass, dimensions and mounting, shall be fitted to the vehicle.

### 7.3 ANCHORAGE OF THE CAB

For test A, the cab shall be mounted on a vehicle. For tests B and C, the cab shall at the Vehicle Manufacturer's/ Truck body builder's choice be mounted either on a vehicle or on a separate frame. The vehicle or frame shall be secured in the manner prescribed in Annex 1.

### 7.4 FRONT IMPACT TEST (TEST A)

#### 7.4.1 Description of the Swing-Bob

- 7.4.1.1 The swing-bob shall be made of steel and its mass shall be evenly distributed; its mass shall be  $1\,500 \pm 250$  kg. Its striking surface, rectangular and flat, shall be 2 500 mm wide and 800 mm high. Its edges shall be rounded to a radius of curvature of not less than 1.5 mm.
- 7.4.1.2 The swing-bob assembly shall be of rigid construction. The swing-bob shall be freely suspended by two beams rigidly attached to it and spaced not less than 1 000 mm apart. The beam shall be of "I" section with a web height of not less than 100 mm or shall be of a section having at least an equivalent moment of inertia. The beams shall be not less than 3 500 mm long from the axis of suspension to the geometric centre of the bob.
- 7.4.1.3 The swing-bob shall be so positioned that in the vertical position
- 7.4.1.3.1 its striking face is in contact with the foremost part of the vehicle;
- 7.4.1.3.2 its centre of gravity is  $50 + 5/ - 0$  mm below the R – point of the driver's seat when the vehicle is in unladen condition, and
- 7.4.1.3.3 its centre of gravity is in the median longitudinal plane of the vehicle.
- 7.4.1.4 The swing-bob shall strike the cab at the front in the direction towards the rear of the cab. The direction of impact shall be horizontal and shall be parallel to the median longitudinal plane of the vehicle. The impact energy shall be 3 000 mkgf for vehicles of a permissible maximum mass up to 7 000 kg and 4 500 mkgf for vehicles for which the permissible maximum mass exceeds this value.

### 7.5 ROOF STRENGTH (TEST B)

The roof of the cab shall withstand a static load corresponding to the maximum mass authorized for the front axle or axles of the vehicle, subject to a maximum of 10 000 kgf. This load shall be distributed uniformly over all the bearing members of the roof structure of the driver's cab or compartment by means of a suitably-shaped rigid former.

**7.6 REAR-WALL STRENGTH (TEST C)**

The rear wall of the cab shall be capable of withstanding a static load of 200 kgf per tonne of permissible useful load. This load shall be applied by means of a rigid barrier perpendicular to the longitudinal median axis of the vehicle, covering at least the whole of the cab rear wall situated above the chassis frame, and moving parallel to that axis.

7.7 The three-dimensional reference system is as per Annex 3.

**Annex: 1**  
( See para 7.3)

**INSTRUCTIONS FOR SECURING VEHICLES TO THE TEST BED**

**1 FRONTAL IMPACT**

Test A shall be applied to a cab mounted on the vehicle in the following way (See Figure 1).

**1.1 Anchoring Chains or Ropes**

Each anchoring chain or rope shall be of steel and shall be capable of withstanding a tractive load of at least 10 000 kgf.

**1.2 Blocking of the Chassis Frame**

The longitudinal members of the chassis frame shall be supported on wooden blocks across their full width and over a length of not less than 150 mm. The front edges of the blocks must not be situated forward of the rearmost point of the cab, nor rearward of the mid-point of the wheel base. At the Vehicle Manufacturer's/ Truck body builder's request the chassis frame shall be set in the attitude it takes up when loaded.

**1.3 Longitudinal Attachment**

Rearward movement of the chassis frame shall be limited by chains or ropes 'A' attached to the front of the chassis frame symmetrically in relation to its longitudinal axis, the points of attachment being not less than 600 mm apart. The chains or ropes shall when tensioned form a downward angle of not more than  $25^{\circ}$  with the horizontal and their projection on a horizontal plane shall form an angle of not more than  $10^{\circ}$  with the longitudinal axis of the vehicle. The chains or ropes may cross one another.

**1.4 Lateral Attachment**

Lateral movement shall be limited by chains or ropes B attached to the chassis frame symmetrically in relation to its longitudinal axis. The points of attachment to the chassis shall be not more than 5 m and not less than 3 m from the front of the vehicle. The chains or ropes shall when tensioned form a downward angle of not more than  $20^{\circ}$  with the horizontal and their projection on a horizontal plane shall form an angle of not less than  $25^{\circ}$  and not more than  $45^{\circ}$  with the longitudinal axis of the vehicle.

**1.5 Tensioning of Chains or Ropes and Rear Attachment**

The chain or rope C shall to begin with be placed under a load of approximately 100 kgf. All slack in the four chains or ropes A and B shall then be taken up and chain or rope C shall be subjected to a tensile stress of not less than 1 000 kgf.



The angle of chain or rope C with the horizontal shall not exceed  $15^{\circ}$ . A vertical blocking force of not less than 50 kgf shall be applied at point D between the chassis frame and the ground.

**1.6 Equivalent Mounting**

At the request of the manufacturer the test may be carried out with the cab mounted on a special frame, on condition that this method of mounting is shown to be equivalent to mounting on the vehicle.

**2. ROOF STRENGTH**

**2.1 Cab Mounted on the Vehicle**

Measures shall be taken to ensure that the vehicle does not shift appreciably during the test. For this purpose the hand brake shall be applied, a gear engaged and the front wheels wedged with chocks. Deformation of the various components of the suspension (springs, tyres, etc.) shall be eliminated by means of rigid members.

**2.2 Cab Mounted on a Frame**

Measures shall be taken to ensure that the frame does not shift appreciably during the test.

**3. STRENGTH OF REAR WALL**

**3.1 Cab Mounted on the Vehicle**

Measures shall be taken to ensure that the vehicle does not shift appreciably during the test. For this purpose the hand brake shall be applied, a gear engaged and the front wheels wedged with chocks.

**3.2 Cab Mounted on a Frame**

Measures shall be taken to ensure that the frame does not shift appreciably during the test.

FRONT IMPACT TEST

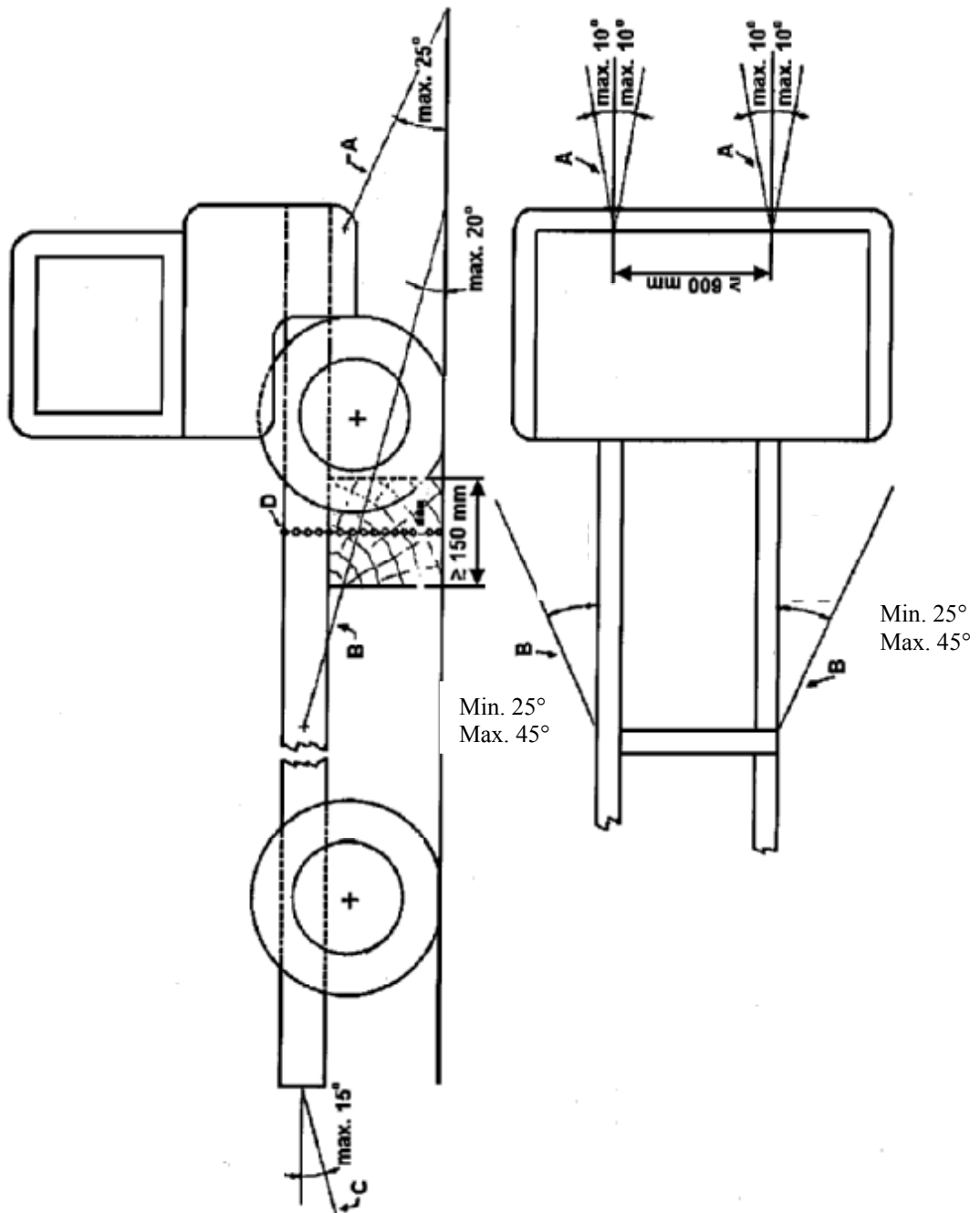
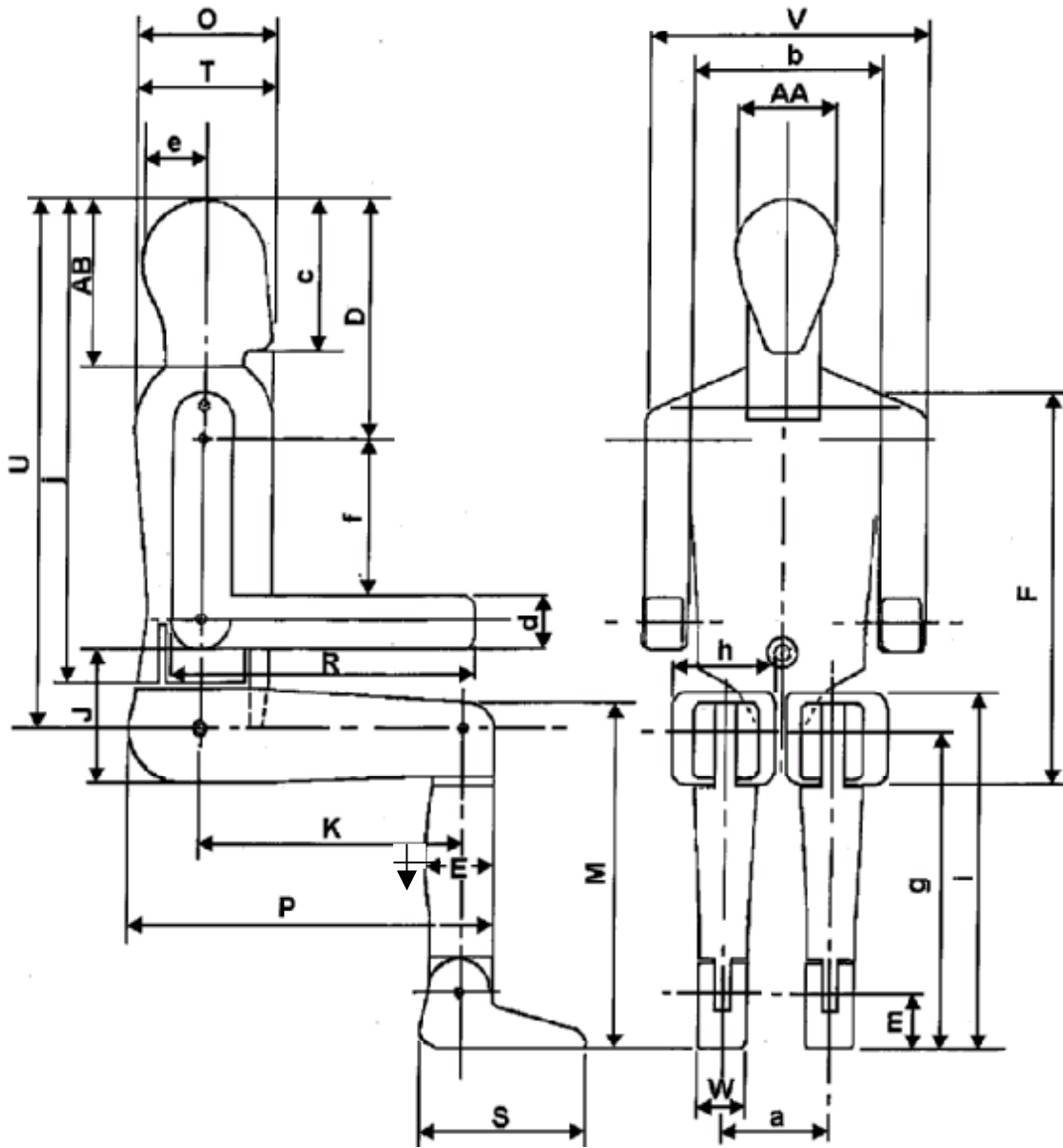

Figure : 1

Cab Mounted on the Vehicle

Annex : 2  
 ( See para. 5.3.1)

MANIKIN TO BE USED TO VERIFY THE SURVIVAL SPACE



( Fiftieth -percentile Male Body)

## DIMENSIONS OF MANIKIN

AA	Breadth of head	15.3 cm
AB	Combined height of head and neck	24.4 cm
D	Distance from top of head to shoulder pivot	35.9 cm
E	Calf depth	10.6 cm
F	Height from seat to top of shoulder	62.0 cm
J	Height of elbow rest	21.0 cm
M	Knee height	54.6 cm
O	Chest depth	23.0 cm
P	Distance from seat back to knee	59.5 cm
R	Distance from elbow to fingertip	49.0 cm
S	Length of foot	26.5 cm
T	Length of head	21.1 cm
U	Height from seat to top of head	90.0 cm
V	Shoulder breadth	45.3 cm
W	Breadth of foot	7.7 cm
a	Distance between hip point centers	17.2 cm
b	Chest breadth	30.5 cm
c	Height of head and chin	22.1 cm
d	Forearm thickness	9.4 cm
e	Distance between vertical centerline of torso and rear of head	10.2 cm
f	Distance between shoulder pivot and elbow pivot	28.3 cm
g	Knee pivot, height from ground	50.5 cm
h	thigh breadth	16.5 cm
i	Lap height (sitting)	56.5 cm
j	Distance from top of head to 'H' point	81.9 cm
k	Distance between hip pivot and knee pivot	42.6 cm
m	Ankle pivot, height from ground	8.9 cm

**Annex : 3**  
( See para.7.7)

**THREE-DIMENSIONAL REFERENCE SYSTEM**

1. The three-dimensional reference system is defined by three orthogonal planes established by the vehicle manufacturer (see Figure1).
2. The vehicle measuring attitude is established by positioning the vehicle on the supporting surface such that the co-ordinates of the fiducial marks correspond to the values indicated by the manufacturer.
3. The co-ordinates of the “R” point and the “H” point are established in relation to the fiducial marks defined by the vehicle manufacturer.

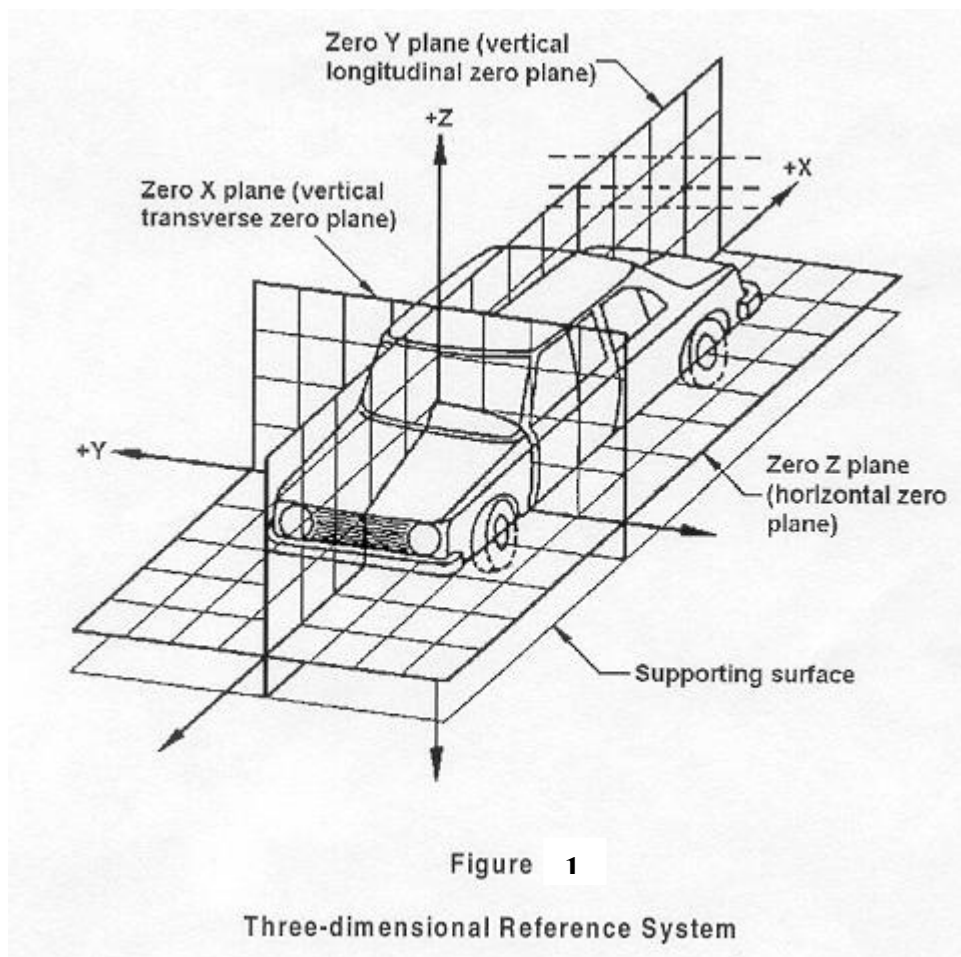

**Annex : 4**  
( See para. 5.3.2)

**REFERENCE DATA CONCERNING SEATING**

**1. CODING OF REFERENCE DATA**

Reference data are listed consecutively for each seating position. Seating positions are identified by a two-digit code. The first digit is an Arabic numeral and designates the row of seats, counting from the front to the rear of the vehicle. The second digit is a capital letter which designates the location of the seating position in a row, as viewed in the direction of forward motion of the vehicle; the following letters shall be used;

L = left  
C = center  
R = right

**2. DESCRIPTION OF VEHICLE MEASURING ATTITUDE**

**2.1 Co-ordinates of Fiducial Marks**

X .....

Y .....

Z .....

**3. LIST OF REFERENCE DATA:**

**3.1 Seating Position:**

**3.1.1 Co-ordinates of "R" point**

X .....

Y .....

Z .....

**3.1.2 Design torso angle:**

**3.1.3 Specifications for seat adjustment [1]**

horizontal : .....

vertical : .....

angular : .....

torso angle : .....

Note: List reference data for further seating positions under 3.2, 3.3, etc.

-----  
[1] Strike out what does not apply.

**Annex : 5**  
( See para. 6.1.3)

**SURVIVAL SPACE FOR THE PROTECTION OF THE  
OCCUPANTS OF THE CAB OF THE COMMERCIAL VEHICLE**

**CRITERIA FOR EXTENSION OF APPROVAL**

<b>Parameter</b>	<b>Change</b>	<b>Test Required</b>
<b>1. General</b>		
R point location	i) R point moved forward ii) R point moved Backward	i) Frontal impact test ii) Rear wall strength
Height of R point from floor level	i) Any increase in height upto 90% of remainder survival space ii) Lowering of 'R' position	i) No test for roof strength ii) No test roof strength
<b>2. Roof strength</b>		
Maximum permissible front axle weight	Increase greater than 10%.	Test
Length of the cabin	Increase greater than 10%.	Test
<b>3. Rear wall strength</b>		
Rear wall apertures	Increase	Test
Type of Cab – fixed / tiltable	Tiltable	Test
Payload	Highest	Test
<b>4. Frontal impact</b>		
Cab mountings		
i) Number of mountings	i) Decreased	i) Test
ii) Quality of fasteners	ii) Superior quality or equivalent	ii) No test
iii) Position of mountings	iii) Any change	iii) Test

Steering gear box mounting	Moved to rear w.r.t. earlier position	No test
Type of steering column – fixed / collapsible	i) Fixed to Collapsible ii) Collapsible to Fixed	i) No test ii) Test
Position of steering column – if adjustable one	i) Tiltable towards R point ii) Tiltable away from R point iii) Longitudinal Movement towards R point	i) Test ii) No test iii) Test
Size of steering wheel	Larger	Test
Thickness of the windshield glass	Thickness decreases	Test
Size of the windshield aperture	Size Increases, largest	Test
Pillar pitch	i) Increase ii) Decrease	i) Test ii) No test
Number of gussets at joints	Increase	No test
Number of reinforcements	Increase	No test
Cross sectional area of the cab structure	Increase	No test
Sheet metal thickness with same material	Increase	No test
Sheet materials	Superior Quality or equivalent	No test



**Annex: 6**  
**(See Introduction)**  
**COMMITTEE COMPOSITION**  
**Automotive Industry Standards Committee**

<b>Chairman</b>	
Shri B. Bhanot	Director The Automotive Research Association of India, Pune
<b>Members</b>	<b>Representing</b>
Shri Alok Rawat	Ministry of Road Transport & Highways, New Delhi
Shri Sushil Kumar	Department of Heavy Industry, Ministry of Heavy Industries & Public Enterprises, New Delhi
Shri G. S. Kashyab Shri M.K. Bhat (Alternate)	Office of the Development Commissioner Small Scale Industries, Ministry of Small Scale Industries, New Delhi
Shri L. R. Singh	Bureau of Indian Standards, New Delhi
Shri A. S. Lakra Shri D. G. Shirke (Alternate)	Central Institute of Road Transport, Pune
Director	Indian Institute of Petroleum, Dehra 'Dun
Shri R. C. Sethi Shri N. Karuppaiah (Alternate)	Vehicles Research & Development Establishment, Ahmednagar
Shri Rajat Nandi	Society of Indian Automobile Manufacturers
Shri T.C. Gopalan Shri Ramakant Garg (Alternate)	Tractor Manufacturers Association, New Delhi
Shri K.N.D. Nambudiripad	Automotive Components Manufacturers Association
Shri G. P. Banerji	Automotive Components Manufacturers Association

**Member Secretary**  
**Mrs. Rashmi Urdhwareshe**  
**Sr. Assistant Director**  
**The Automotive Research Association of India, Pune**