

AMENDMENT NO. 3 (02/2019)

To

AIS-099

**Approval of Vehicles with regards to the Protection of the Occupants
in the event of a Lateral Collision**

1. Page No. 3/92, Add new definitions Clause 2.35 to Clause 2.38 as follows

- "2.35. **"Latched"** means any coupling condition of the door latch system, where the latch is in a fully latched position, a secondary latched position, or in between a fully latched position and a secondary latched position.
- 2.36. **"Latch"** is a device employed to maintain the door in a closed position relative to the vehicle body with provisions for deliberate release (or operation).
- 2.37. **"Fully latched position"** is the coupling condition of the latch that retains the door in a completely closed position.
- 2.38. **"Secondary latched position"** refers to the coupling condition of the latch that retains the door in a partially closed position."

2. Page No. 5/92, Paragraph 5.3.1., amend to read:

"5.3.1. No door shall open during the test.

This requirement is deemed to be fulfilled:

- (a) If it is clearly visible, that the door lock is latched; or
- (b) If the door does not open under a static tractive force of at least 400 N in the y-direction applied to the door, according to the Figure below, as close as possible to the window sill and to the edge of the door opposite to the hinged side, except to the door handle itself.

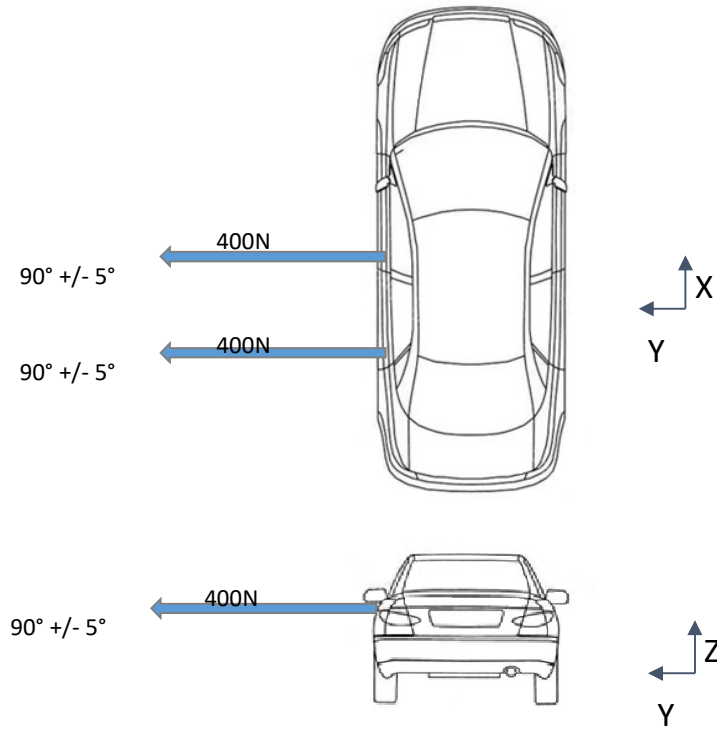

PRINTED BY
THE AUTOMOTIVE RESEARCH ASSOCIATION OF INDIA
P.B. NO. 832, PUNE 411 004
ON BEHALF OF
AUTOMOTIVE INDUSTRY STANDARDS COMMITTEE
UNDER
CENTRAL MOTOR VEHICLE RULES – TECHNICAL STANDING COMMITTEE
SET-UP BY
MINISTRY OF ROAD TRANSPORT & HIGHWAYS
(DEPARTMENT OF ROAD TRANSPORT & HIGHWAYS)
GOVERNMENT OF INDIA
6th February 2019

AMENDMENT NO. 2 28 September 2016

To

AIS-099

Approval of Vehicles with regards to the Protection of the Occupants in the event of a Lateral Collision

1. Page No. III, Para 5 , INTRODUCTION

Substitute following figure for existing one:

“UN R 95 (Supp. 04 to 03 Series of Amd.)”

2. Page No. 4/13 and 5/13, Amendment 1, Specifications

Substitute following text for existing text in paragraph 5.3.6.1.:

“5.3.6.1. Protection against electrical shock

After the impact at least one of the four criteria specified in paragraphs 5.3.6.1.1 to 5.3.6.1.4. shall be met.

If the vehicle has an automatic disconnect function or device(s) that galvanically divide the electrical power train circuit during driving condition, at least one of the following criteria shall apply to the disconnected circuit or to each divided circuit individually after the disconnect function is activated.

However criteria defined in 5.3.6.1.4 shall not apply if more than a single potential of a part of the high voltage bus is not protected under the conditions of protection degree IPXXB.

In the case that the test is performed under the condition that part(s) of the high voltage system are not energized, the protection against electrical shock shall be proved by either paragraph 5.3.6.1.3 or paragraph 5.3.6.1.4 for the relevant part(s).

For the coupling system for charging the REESS, which is not energised during driving conditions, at least one of the four criteria specified in paragraphs 5.3.6.1.1 to 5.3.6.1.4 below shall be met.”

3. Page No. 7/92, Paragraph no. 6 -MODIFICATION OF THE VEHICLE TYPE.

Insert new paragraph 6.4 to be read as follows:

“6.4 For deciding on the worst case or requirement of retest/partial test for extension of an existing type approval, the appropriate available data (i.e. test results/test reports/videos/pictures etc.) provided by the manufacturer may be used with the approval of the test agency.”

PRINTED BY
THE AUTOMOTIVE RESEARCH ASSOCIATION OF INDIA
P.B. NO. 832, PUNE 411 004
ON BEHALF OF
AUTOMOTIVE INDUSTRY STANDARDS COMMITTEE
UNDER
CENTRAL MOTOR VEHICLE RULES – TECHNICAL STANDING COMMITTEE
SET-UP BY
MINISTRY OF ROAD TRANSPORT & HIGHWAYS
(DEPARTMENT OF ROAD TRANSPORT & HIGHWAYS)
GOVERNMENT OF INDIA
28 September 2016

AMENDMENT NO. 1 15 December 2015

To

AIS-099

Approval of Vehicles with regards to the Protection of the Occupants in the event of a Lateral Collision

1. Page No. III, Para 5, INTRODUCTION

Substitute following text for first two lines of existing text:

UN R 95 (Supp. 02 to 03 Series of Amd.)	Uniform provisions regarding the protection of occupants in a lateral collision.
--	---

2. Page No. III, Para 6 , INTRODUCTION

Substitute following text for existing text and Add new para after para 6 as given below:

The Automotive Industry Standards Committee responsible for preparation of this standard is given in Annex: 8

Amendment No. 1 is issued to incorporate requirements for the protection of the occupants of vehicles operating on electrical power.

3. Page No. 1/92, Clause 0.2. ,Scope

Substitute following text for existing text:

0.2 The vehicles which have complied with the requirements of this standard shall be deemed to have complied with IS 12009: 1995 as amended time to time.

4. Page 2/92. Add following new Clause 2.2.8. after clause 2.2.7.:

2.2.8 The locations of the Rechargeable Electrical Energy Storage Systems (REESS), in so far as they have a negative effect on the result of the impact test prescribed in this Standard.

5. Page 2/92. Clause 2.3.

Substitute following text for existing text:

2.3. "Passenger compartment"

2.3.1. "Passenger compartment with regard to occupant protection" means the space for occupant accommodation, bounded by the roof, floor, side walls, doors, outside glazing and front bulkhead and the plane of the rear compartment bulkhead or the plane of the rear-seat back support;

2.3.2. "Passenger compartment for electric safety assessment" means the space for occupant accommodation, bounded by the roof, floor, side walls, doors, outside glazing, front bulkhead and rear bulkhead, or rear gate, as well as by the electrical protection barriers and enclosures provided for protecting the occupants from direct contact with high voltage live parts.

6. Page No. 3/92, Clause 2.15. to Clause 2.20.

Delete text "(Reserved)" and Add new definitions as follows:

2.15. "High voltage" means the classification of an electric component or circuit, if its working voltage is as follows–

$$60V < \text{working voltage (DC)} \leq 1500 V \text{ or} \\ 30 V < \text{working voltage (AC) rms} \leq 1000 V;$$

2.16. "Rechargeable electrical energy storage system (REESS)" means rechargeable electrical energy storage system which provides electrical energy for propulsion;

2.17. "Electrical protection barrier" the part providing protection against any direct contact to the high voltage live parts;

2.18. "Electrical power train" means the electrical circuit which includes the traction motor(s), and may also include the REESS, the electrical energy conversion system, the electronic converters, the associated wiring harness and connectors, and the coupling system for charging the REESS;

2.19. "Live parts" means conductive part(s) intended to be electrically energized in normal use;

2.20. "Exposed conductive part" means the conductive part which can be touched under the provisions of the protection degree IPXXB and which becomes electrically energized under isolation failure conditions. This includes parts under a cover that can be removed without using tools.

7. Page No. 3/92,

Add new definitions Clause 2.21 to Clause 2.34 as follows:

- 2.21. "Direct contact" means the contact of persons with high voltage live parts;
- 2.22 "Indirect contact" means the contact of persons with exposed conductive parts;
- 2.23 "Protection Degree IPXXB" means protection from contact with high voltage live parts provided by either an electrical protection barrier or an enclosure and tested using a Jointed Test Finger (Degree IPXXB) as described in paragraph 4. of Annex 7;
- 2.24 "Working voltage" means the highest value of an electrical circuit voltage root-mean-square (rms), specified by the vehicle manufacturer, which may occur between any conductive parts in open circuit conditions or under normal operating conditions. If the electrical circuit is divided by galvanic isolation, the working voltage is defined for each divided circuit, respectively;
- 2.25 "Coupling system for charging the rechargeable electrical energy storage system (REESS)" means the electrical circuit used for charging the REESS from an external electrical power supply including the vehicle inlet;
- 2.26 "Electrical chassis" means a set made of conductive parts electrically linked together, whose electrical potential is taken as reference;
- 2.27 "Electrical circuit" means an assembly of connected high voltage live parts which is designed to be electrically energized in normal operation;
- 2.28 "Electric energy conversion system" means a system that generates and provides electrical energy for electrical propulsion;
- 2.29 "Electronic converter" means a device capable of controlling and/or converting electrical power for electrical propulsion;
- 2.30 "Enclosure" means the part enclosing the internal units and providing protection against any direct contact;
- 2.31 "High Voltage Bus" means the electrical circuit, including the coupling system for charging the REESS that operates on a high voltage;
- 2.32 "Solid insulator" means the insulating coating of wiring harnesses provided in order to cover and prevent the high voltage live parts from any direct contact. This includes covers for insulating the high voltage live parts of connectors; and varnish or paint for the purpose of insulation;
- 2.33 "Automatic disconnect" means a device that when triggered, galvanically separates the electrical energy sources from the rest of the high voltage circuit of the electrical power train;
- 2.34 "Open type traction battery" means a type of battery requiring liquid and generating hydrogen gas released to the atmosphere.

8. Page No. 3/92, Clause 2.21.

Clause 2.21. (former) rename as Clause 2.35

9. Page No. 4/92, APPLICATION FOR APPROVAL

Add following new Clause 3.2.6. after Clause 3.2.5.

3.2.6 A general description of the electrical power source type, location and the electrical power train (e.g. hybrid, electric).

10. Page No. 5/92, Specifications

Substitute following paragraph before Clause no. 5.2.1.:

5.2 Performance criteria

Additionally, vehicles equipped with electric power train shall meet the requirements of paragraph 5.3.6 below. This can be met by a separate impact test at the request of the vehicle manufacturer and after validation by the Technical Service, provided that the electrical components do not influence the occupant protection performance as defined in paragraphs 5.2.1 to 5.3.4 of this standard of the vehicle type in consideration. In case of this condition the requirements of paragraph 5.3.6 shall be checked in accordance with the methods set out in Annex 1 to this standard, except paragraphs 6, 7 and Appendices 1 and 2. The side-impact dummy shall be installed in the front seat on the impact side.

11. Page No. 6/92, Specifications

Add new Clause 5.3.6. with sub-clauses after Clause 5.3.5. as given below:

5.3.6. Following the test conducted in accordance with the procedure defined in Annex 1 to this Standard the electrical power train operating on high voltage and the high voltage components and systems which are galvanically connected to the high voltage bus of the electrical power train shall meet the following requirements:

5.3.6.1. Protection against electrical shock

After the impact at least one of the four criteria specified in paragraphs 5.3.6.1.1 to 5.3.6.1.4. shall be met.

If the vehicle has an automatic disconnect function or device(s) that galvanically divide the electrical power train circuit during driving condition, at least one of the following criteria shall apply to the disconnected circuit or to each divided circuit individually after the disconnect function is activated.

However criteria defined in 5.3.6.1.4 shall not apply if more than a single potential of a part of the high voltage bus is not protected under the conditions of protection degree IPXXB.

In the case that the test is performed under the condition that part(s) of the high voltage system are not energized, the protection against electrical shock shall be proved by either paragraph 5.3.6.1.3 or paragraph 5.3.6.1.4 for the relevant part(s).

5.3.6.1.1 Absence of high voltage

The voltages V_b , V_1 and V_2 of the high voltage buses shall be $\leq 30 V_{AC}$ or $60 V_{DC}$ as specified in paragraph 2. of Annex 7.

5.3.6.1.2. Low electrical energy

The total energy (TE) on the high voltage buses shall be $< 2.0 J$ when measured according to the test procedure as specified in paragraph 3, formula (a) of Annex 7. Alternatively the total energy (TE) may be calculated by the measured voltage V_b of the high voltage bus and the capacitance of the X-capacitors (C_x) specified by the vehicle manufacturer in paragraph 3, formula (b) of Annex 7.

The energy stored in the Y-capacitors (TE_{y1} , TE_{y2}) shall also be $< 2.0 J$. This shall be calculated by measuring the voltages V_1 and V_2 of the high voltage buses and the electrical chassis, and the capacitance of the Y-capacitors specified by the vehicle manufacturer according to formula (c) in paragraph 3 of Annex 7.

5.3.6.1.3 Physical protection

For protection against direct contact with high voltage live parts, the protection degree IPXXB shall be provided.

In addition, for protection against electrical shock, which could arise from indirect contact, the resistance between all exposed conductive parts and the electrical chassis shall be $< 0.1 \Omega$ when there is current flow of at least 0.2 Amp.

This requirement is satisfied if the galvanic connection has been made by welding.

5.3.6.1.4 Isolation resistance

The criteria specified in the paragraphs 5.3.6.1.4.1 and 5.3.6.1.4.2 below shall be met.

The measurement shall be conducted in accordance with paragraph 5. of Annex 7.

5.3.6.1.4.1 Electrical power train consisting of separate DC- or AC-buses

If the AC high voltage buses and the DC high voltage buses are galvanically isolated from each other, isolation resistance between the high voltage bus and the electrical chassis (R_i as defined in paragraph 5. of Annex 7) shall have a minimum value of $100 \Omega/\text{volt}$ of the working voltage for DC buses, and a minimum value of $500 \Omega/\text{volt}$ of the working voltage for AC buses.

5.3.6.1.4.2. Electrical power train consisting of combined DC- and AC-buses

If the AC high voltage buses and the DC high voltage buses are galvanically connected isolation resistance between the high voltage bus and the electrical chassis (R_i as defined in paragraph 5. of Annex 7) shall have a minimum value of 500 Ω /volt of the working voltage.

However, if the protection degree IPXXB is satisfied for all AC high voltage buses or the AC voltage ≤ 30 V after the vehicle impact, the isolation resistance between the high voltage bus and the electrical chassis (R_i as defined in paragraph 5 of Annex 7) shall have a minimum value of 100 Ω /volt of the working voltage.

5.3.6.2. Electrolyte spillage

In the period, from the impact until 30 minutes after, no electrolyte from the REESS shall spill into the passenger compartment, and no more than 7 % of electrolyte shall spill from the REESS except, open type traction batteries outside the passenger compartment. For open type traction batteries no more than 7 % with a maximum of 5.0 liters shall spill outside the passenger compartment. The vehicle manufacturer shall demonstrate compliance in accordance with paragraph 6. of Annex 7.

5.3.6.3. REESS retention

REESS located inside the passenger compartment shall remain in the location in which they are installed and REESS components shall remain inside REESS boundaries.

No part of any REESS that is located outside the passenger compartment for electrical safety assessment shall enter the passenger compartment during or after the impact test.

The manufacture shall demonstrate compliance in accordance with paragraph 7 of Annex 7.

12. Page No. 9/92, Annex 1, Preparation of the vehicle

Substitute following text for existing text in Clause 5.2.:

5.2. The doors shall be closed, but not locked. Vehicle models equipped with Automatic door locking systems shall be tested with Automatic locking system de-activated.

13. Page No. 10/92, Annex 1, Preparation of the vehicle

Add following new Clause no. 5.11. Including sub-clauses after clause no. 5.10.

5.11. Electrical power train adjustment

5.11.1. The REESS shall be at any state of charge, which allows the normal operation of the power train as recommended by the vehicle manufacturer.

5.11.2. The electrical power train shall be energized with or without the operation of the original electrical energy sources (e.g. engine-generator, REESS or electric energy conversion system), however:

5.11.2.1. By the agreement between Test Agency and vehicle manufacturer it shall be permissible to perform the test with all or parts of the electrical power train not being energized in so far as there is no negative influence on the test result. For parts of the electrical power train not energized, the protection against electrical shock shall be proved by either physical protection or isolation resistance and appropriate additional evidence.

5.11.2.2. In the case where an automatic disconnect is provided, at the request of the vehicle manufacturer it shall be permissible to perform the test with the automatic disconnect being triggered. In this case it shall be demonstrated that the automatic disconnect would have operated during the impact test. This includes the automatic activation signal as well as the galvanic separation considering the conditions as seen during the impact.

14. Page No. 92/92, Add new section “Annex 7” and substitute title “Annex 8” to “Annex 7”(former) as below:

ANNEX 7

Test Procedures for the protection of the occupants of vehicles operating on electrical power from high voltage and electrolyte spillage

This annex describes test procedures to demonstrate compliance to the electrical safety requirements of paragraph 5.3.6. For example, megohmmeter or oscilloscope measurements are an appropriate alternative to the procedure described below for measuring isolation resistance. In this case it may be necessary to deactivate the on-board isolation resistance monitoring system.

Before the vehicle impact test conducted, the high voltage bus voltage (V_b) (see figure 1) shall be measured and recorded to confirm that it is within the operating voltage of the vehicle as specified by the vehicle manufacturer.

1. Test setup and equipment

If a high voltage disconnect function is used, measurements are to be taken from both sides of the device performing the disconnect function.

However, if the high voltage disconnect is integral to the REESS or the electrical energy conversion system and the high-voltage bus of the REESS or the electrical energy conversion system is protected according to protection degree IPXXB following the impact test, measurements may only be taken between the device performing the disconnect function and the electrical loads.

The voltmeter used in this test shall measure DC values and have an internal resistance of at least 10 M Ω .

2. The following instructions may be used if voltage is measured.

After the impact test, determine the high voltage bus voltages (V_b , V_1 , V_2) (see figure 1).

The voltage measurement shall be made not earlier than 5 seconds but not later than 60 seconds after the impact.

This procedure is not applicable if the test is performed under the condition where the electrical power train is not energized.

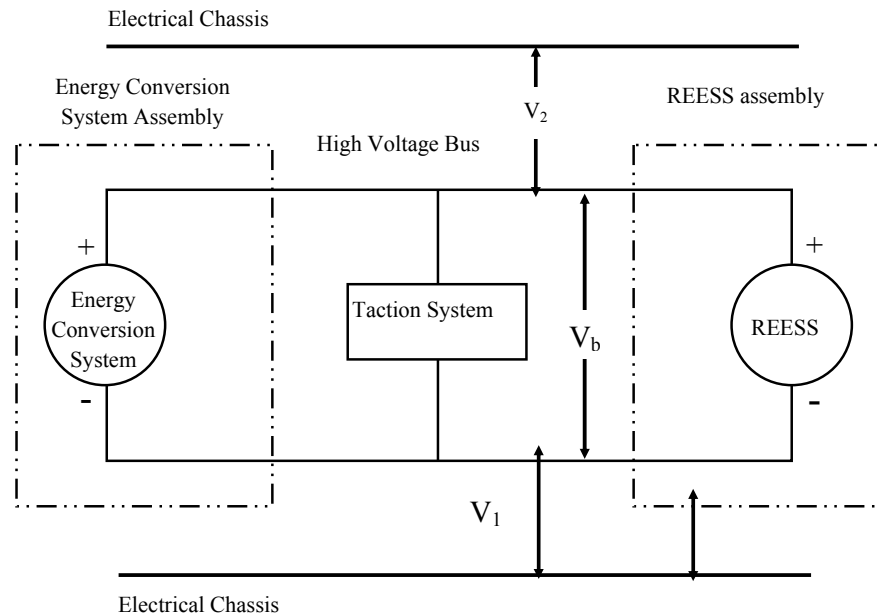

Figure 1 Measurement of V_b , V_1 , V_2

3. Assessment procedure for low electrical energy

Prior to the impact a switch S_1 and a known discharge resistor R_e is connected in parallel to the relevant capacitance (ref. figure 2).

Not earlier than 5 seconds and not later than 60 seconds after the impact the switch S_1 shall be closed while the voltage V_b and the current I_e are measured and recorded. The product of the voltage V_b and the current I_e shall be integrated over the period of time, starting from the moment when the switch S_1 is closed (t_c) until the voltage V_b falls below the high voltage threshold of 60 V DC (t_h). The resulting integration equals the total energy (TE) in J:

$$(a) \quad TE = \int_{t_c}^{t_h} V_b \times I_e dt$$

When V_b is measured at a point in time between 5 seconds and 60 seconds after the impact and the capacitance of the X-capacitors (C_x) is specified by the vehicle manufacturer, total energy (TE) shall be calculated according to the following formula:

(b)
$$TE = 0.5 \times C_x \times (V_b^2 - 3600)$$

When V_1 , V_2 (see figure 1) are measured at a point in time between 5 seconds and 60 seconds after the impact and the capacitances of the Y-capacitors (C_{y1} , C_{y2}) are specified by the vehicle manufacturer, total energy (TE_{y1} , TE_{y2}) shall be calculated according to the following formulas:

(c)
$$TE_{y1} = 0.5 \times C_{y1} \times (V_1^2 - 3600)$$

$$TE_{y2} = 0.5 \times C_{y2} \times (V_2^2 - 3600)$$

This procedure is not applicable if the test is performed under the condition where the electrical power train is not energized.

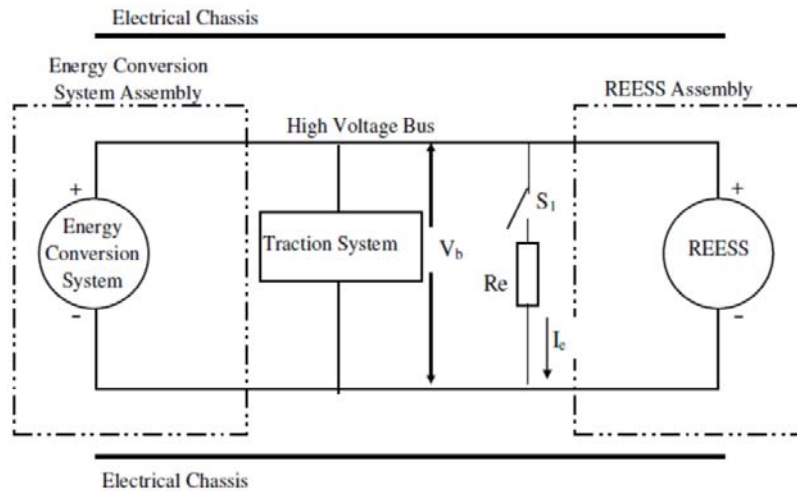

Figure 2
E.g. measurement of high voltage bus energy stored in X-capacitors

4. Physical protection

Following the vehicle impact test any parts surrounding the high voltage components shall be, without the use of tools, opened, disassembled or removed. All remaining surrounding parts shall be considered part of the physical protection.

The Jointed Test Finger described in Appendix 1 figure 1 shall be inserted into any gaps or openings of the physical protection with a test force of $10 \text{ N} \pm 10 \%$ for electrical safety assessment. If partial or full penetration into the physical protection by the Jointed Test Finger occurs, the Jointed Test Finger shall be placed in every position as specified below.

Starting from the straight position, both joints of the test finger shall be rotated progressively through an angle of up to 90 degrees with respect to the axis of the adjoining section of the finger and shall be placed in every possible position.

Internal barriers are considered part of the enclosure.
If appropriate a low-voltage supply (of not less than 40 V and not more than 50 V) in series with a suitable lamp should be connected, between the Jointed Test Finger and high voltage live parts inside the electrical protection barrier or enclosure.

4.1. Acceptance conditions

The requirements of paragraph 5.3.6.1.3. shall be considered to be met if the Jointed Test Finger described in Annex 7, Appendix 1, figure 1 is unable to contact high voltage live parts.

If necessary a mirror or a fiberscope may be used in order to inspect whether the Jointed Test Finger touches the high voltage buses.

If this requirement is verified by a signal circuit between the Jointed Test Finger and high voltage live parts, the lamp shall not light.

5. Isolation resistance

The isolation resistance between the high voltage bus and the electrical chassis may be demonstrated either by measurement or by a combination of measurement and calculation.

The following instructions should be used if the isolation resistance is demonstrated by measurement.

Measure and record the voltage (V_b) between the negative and the positive side of the high voltage bus (see figure 1):

Measure and record the voltage (V_1) between the negative side of the high voltage bus and the electrical chassis (see figure 1):

Measure and record the voltage (V_2) between the positive side of the high voltage bus and the electrical chassis (see figure 1):

If V_1 is greater than or equal to V_2 , insert a standard known resistance (R_o) between the negative side of the high voltage bus and the electrical chassis. With R_o installed, measure the voltage (V_1') between the negative side of the high voltage bus and the vehicle electrical chassis (see figure 3). Calculate the isolation resistance (R_i) according to the formula shown below.

$$R_i = R_o * (V_b / V_1' - V_b / V_1) \quad \text{or} \quad R_i = R_o * V_b * (1 / V_1' - 1 / V_1)$$

Divide R_i , which is the electrical isolation resistance value (in Ω) by the working voltage of the high voltage bus in volt (V).

$$R_i (\Omega / V) = R_i (\Omega) / \text{Working voltage (V)}$$

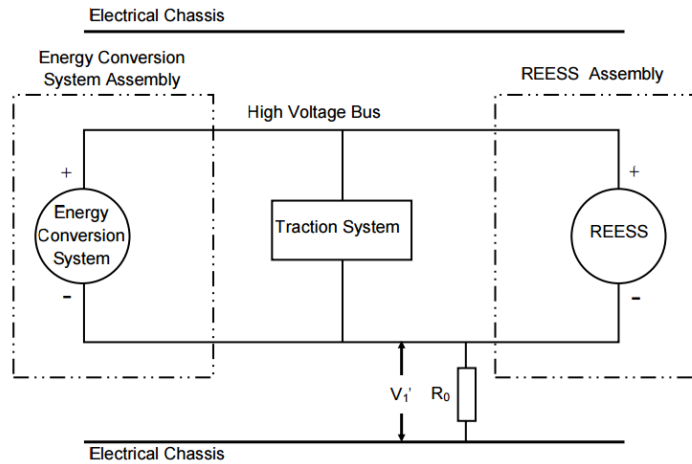

Figure 3 Measurement of V_1 '

If $V_2 > V_1$, insert a standard known resistance (R_0) between the positive side of the high voltage bus and the electrical chassis. With R_0 installed, measure the voltage (V_2') between the positive side of the high voltage bus and the electrical chassis (see figure 4).

Calculate the isolation resistance (R_i) according to the formula shown below.

$$R_i = R_0 * (V_b / V_2' - V_b / V_2) \quad \text{or} \quad R_i = R_0 * V_b * (1 / V_2' - 1 / V_2)$$

Divide R_i , which is the electrical isolation resistance value (in Ω) by the working voltage of the high voltage bus in volt (V).

$$R_i (\Omega / V) = R_i (\Omega) / \text{Working voltage (V)}$$

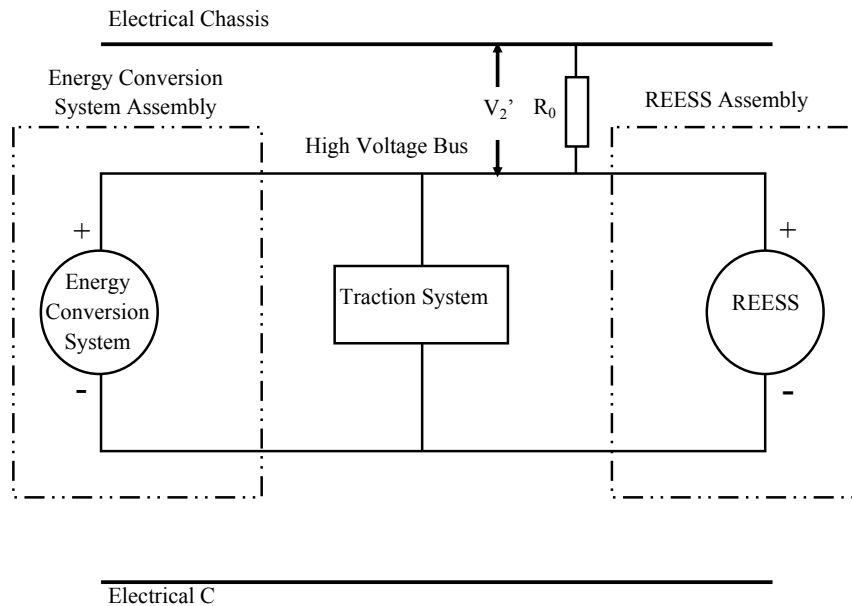

Figure 4 Measurement of V_2'

Note: The standard known resistance R_0 (Ω) should be the value of the minimum required isolation resistance (Ω / V) multiplied by the working

Material: metal, except where otherwise specified

Linear dimensions in millimeters

Tolerances on dimensions without specific tolerance:

(a) On angles: 0/-10 degrees

(b) On linear dimensions: up to 25 mm: 0/-0.05 mm over 25 mm: ± 0.2 mm

Both joints shall permit movement in the same plane and the same direction through an angle of 90° with a 0 to $+10^\circ$ tolerance.

PRINTED BY
THE AUTOMOTIVE RESEARCH ASSOCIATION OF INDIA
P.B. NO. 832, PUNE 411 004
ON BEHALF OF
AUTOMOTIVE INDUSTRY STANDARDS COMMITTEE
UNDER
CENTRAL MOTOR VEHICLE RULES – TECHNICAL STANDING
COMMITTEE
SET-UP BY
MINISTRY OF ROAD TRANSPORT & HIGHWAYS
(DEPARTMENT OF ROAD TRANSPORT & HIGHWAYS)
GOVERNMENT OF INDIA
15 December 2015

AIS-099

AUTOMOTIVE INDUSTRY STANDARD

**Approval of Vehicles with regards to
the Protection of the Occupants in the
event of a Lateral Collision**

PRINTED BY
THE AUTOMOTIVE RESEARCH ASSOCIATION OF INDIA
P.B. NO. 832, PUNE 411 004

ON BEHALF OF
AUTOMOTIVE INDUSTRY STANDARDS COMMITTEE

UNDER
CENTRAL MOTOR VEHICLE RULES – TECHNICAL STANDING COMMITTEE

SET-UP BY
MINISTRY OF SHIPPING, ROAD TRANSPORT & HIGHWAYS
(DEPARTMENT OF ROAD TRANSPORT & HIGHWAYS)
GOVERNMENT OF INDIA

August 2008

Status chart of the standard to be used by the purchaser for updating the record

Sr. No.	Corr-igenda.	Amend-ment	Revision	Date	Remark	Misc.

General remarks:

INTRODUCTION

The Government of India felt the need for a permanent agency to expedite the publication of standards and development of test facilities in parallel when the work on the preparation of the standards is going on, as the development of improved safety critical parts can be undertaken only after the publication of the standard and commissioning of test facilities. To this end, the erstwhile Ministry of Surface Transport (MoST) has constituted a permanent Automotive Industry Standards Committee (AISC) vide order No. RT-11028/11/97-MVL dated September 15, 1997. The standards prepared by AISC will be approved by the permanent CMVR Technical Standing Committee (CTSC). After approval, the Automotive Research Association of India, (ARAI), Pune, being the secretariat of the AIS Committee, has published this standard.

Based on deliberations in the CMVR-TSC and AISC it has been decided to create a suite of standards related to Passive Safety which are founded on dynamic (or crash) testing of passenger cars and utility vehicles. These standards would then form the basis of the notification and implementation of advanced passive safety norms in the latter part of this decade as per the Safety Road Map adopted for India.

This is the third standard in the series prepared for assessment of crash protection to the occupants in the event of lateral collision of passenger cars. Currently the vehicles have been assessed by a quasi static door intrusion test as per IS 12009 : 1995. This standard upgrades the quasi static requirements of IS 12009 to higher level dynamic assessments.

While preparing this AIS considerable assistance is derived from following International standards:

ECE R 95 (Supp.1 to 02 Series of Amd.)	Uniform provisions regarding the protection of occupants in a lateral collision.
EEC Directive 96/27/EEC (Issue 1, February 2002)	Side impact resistance of motor vehicles
ISO 10997: 1996	Passenger vehicles – Side Impact with deformable moving barrier – Full scale test

The Automotive Industry Standards Committee responsible for preparation of this standard is given in Annex : 7

Approval of vehicles with regards to the protection of the Occupants in the event of a Lateral Collision

0 SCOPE

This standard applies to the lateral collision behaviour of the structure of the passenger compartment of M₁ and N₁ categories of vehicles where the R Point of the lowest seat is not more than 700 mm from ground level when the vehicle is in the condition corresponding to the reference mass defined in paragraph 2.10 of this standard.

- 0.1 This standard shall not apply to multi-stage build vehicles produced in quantities not exceeding 500 vehicles in any period of 12 months duration.
- 0.2 The vehicles which have complied with the requirements of this standard shall be deemed to have complied with IS 12009 : 1995.

1. REFERENCES

1.1	IS 12009 : 1995	Automotive Vehicle - Safety Requirements for Side Door of Passenger Cars – Recommendations
1.2	AIS-097	Procedure for Determining the "H" Point and the Torso Angle for 50 th Percentile Adult Male in Seating Positions of Motor Vehicles
1.3	ISO:6487-1987	Road vehicles – Measurement Techniques in Impact Tests – Instrumentation
1.4	SAE J211	Instrumentation for Impact Test

2 DEFINITIONS

For the purposes of this standard:

- 2.1 "**Approval of a vehicle**" means the approval of a vehicle type with regard to the behaviour of the structure of the passenger compartment in a lateral collision;
- 2.2 "**Vehicle type**" means a category of power-driven vehicles which do not differ in such essential respects as:
 - 2.2.1 the length, width and ground clearance of the vehicle, in so far as they have a negative effect on the performance prescribed in this standard;

- 2.2.2 the structure, dimensions, lines and materials of the side walls of the passenger compartment in so far as they have a negative effect on the performance prescribed in this standard;
- 2.2.3 the lines and inside dimensions of the passenger compartment and the type of protective systems, in so far as they have a negative effect on the performance prescribed in this standard;
- 2.2.4 the siting of the engine (front, rear or centre);
- 2.2.5 the unladen mass, in so far as there is a negative effect on the performance prescribed in this standard;
- 2.2.6 the optional arrangements or interior fittings in so far as they have a negative effect on the performance prescribed in this standard;
- 2.2.7 the type of front seat(s) and position of the "R" Point in so far as they have a negative effect on the performance prescribed in this standard;
- 2.3 **"Passenger compartment"** means the space for occupant accommodation, bounded by the roof, floor, side walls, doors, outside glazing and front bulkhead and the plane of the rear compartment bulkhead or the plane of the rear-seat back support;
- 2.4 **"R Point"** or "seating reference point" means the reference point specified by the vehicle manufacturer which:
- 2.4.1 has co-ordinates determined in relation to the vehicle structure;
- 2.4.2 corresponds to the theoretical position of the point of torso/thighs rotation (H Point) for the lowest and most rearward normal driving position or position of use given by the vehicle manufacturer for each seating position specified by him;
- 2.5 **"H Point"** means the point as defined in AIS-097;
- 2.6 **"Capacity of the fuel tanks"** means the fuel-tank capacity as specified by the manufacturer of the vehicle;
- 2.7 **"Transverse plane"** means a vertical plane perpendicular to the median longitudinal vertical plane of the vehicle;
- 2.8 **"Protective system"** means devices intended to restrain and/or protect the occupants;
- 2.9 **"Type of protective system"** means a category of protective devices which do not differ in such essential respects as their:
Technology,
Geometry,
constituent materials;

- 2.10 **"Reference mass"** means the unladen mass of the vehicle increased by a mass of 100 kg (that is the mass of the side impact dummy and its instrumentation);
- 2.11 **"Unladen mass"** means the mass of the vehicle in running order without driver, passengers or load, but with the fuel tank filled to 90% of its capacity and the usual set of tools and spare wheel on board, where applicable;
- 2.12 **"Mobile deformable barrier"** means the apparatus with which the test vehicle is impacted. It consists of a trolley and an impactor;
- 2.13 **"Impactor"** means a crushable section mounted on the front of mobile deformable barrier;
- 2.14 **"Trolley"** means a wheeled frame free to travel along its longitudinal axis at the point of impact. Its front supports the impactor.
- 2.15 (Reserved)
- 2.16 (Reserved)
- 2.17 (Reserved)
- 2.18 (Reserved)
- 2.19 (Reserved)
- 2.20 (Reserved)
- 2.21 **'Multi-stage build'** means the procedure whereby two or more manufacturers separately and sequentially participate in the construction of a vehicle.

3 APPLICATION FOR APPROVAL

- 3.1 The application for approval of a vehicle type with regard to the protection of the occupants in the event of a lateral collision shall be submitted by the vehicle manufacturer or by his duly accredited representative.
- 3.2 It shall be accompanied by the under-mentioned documents in triplicate and the following particulars:
 - 3.2.1 a detailed description of the vehicle type with respect to its structure, dimensions, lines and constituent materials;
 - 3.2.2 photographs and/or diagrams and drawings of the vehicle showing the vehicle type in front, side and rear elevation and design details of the lateral part of the structure;

- 3.2.3 particulars of the vehicle's mass as defined by paragraph 2.11. of this standard;
- 3.2.4 the lines and inside dimensions of the passenger compartment;
- 3.2.5 a description of the relevant side interior fittings and protective systems installed in the vehicle.
- 3.3 The applicant for approval shall be entitled to present any data and results of tests carried out which make it possible to establish that compliance with the requirements can be achieved on prototype vehicles with a sufficient degree of accuracy.
- 3.4 A vehicle which is representative of the type to be approved shall be submitted to the testing agency responsible for conducting the approval tests.
 - 3.4.1 A vehicle not comprising all the components proper to the type may be accepted for tests provided that it can be shown that the absence of the components omitted has no detrimental effect on the performance prescribed in the requirements of this standard.
 - 3.4.2 It shall be the responsibility of the applicant for approval to show that the application of paragraph 3.4.1 is in compliance with the requirements of this standard.

4 APPROVAL

- 4.1 If the vehicle type submitted for approval pursuant to this standard meets the requirements of paragraph 5 below, approval of that vehicle type shall be granted.
- 4.2 In case of doubt, account shall be taken, when verifying the conformity of the vehicle to the requirements of this standard, of any data or test results provided by the manufacturer which can be taken into consideration in validating the approval test carried out by the testing agency.

5 SPECIFICATIONS AND TESTS

- 5.1 The vehicle shall undergo a test in accordance with Annex 1 of this standard
 - 5.1.1 The test shall be carried out on the driver's side unless asymmetric side structures, if any, are so different so as to affect the performance in a side impact. In that case either of the alternatives in paragraph 5.1.1.1 to 5.1.1.2 may be used by agreement between the manufacturer and testing agency.

- 5.1.1.1 The manufacturer will provide the authority responsible for approval with information regarding the compatibility of performances in comparison with the drivers side when the test is being carried out on that side
- 5.1.1.2 The approval authority, if concerned as to the construction of the vehicle, will decide to have the test performed on the side opposite to the driver, this being considered to the least favorable.
- 5.1.2 The testing agency after consultation with the manufacturer may require the test to be carried out with the seat in position other than the one indicated in paragraph 5.5.1 of Annex 1. The position shall be indicated in the test report.
- 5.1.3 The results of this test shall be considered satisfactory if the conditions set out in the paragraphs 5.2 and 5.3 below are satisfied.

5.2 Performance criteria

- 5.2.1 The performance criteria, as determined for the collision test in accordance with the Appendix to Annex 1 to this standard shall meet the following conditions:
- 5.2.2 the head performance criterion (HPC) shall be less than or equal to 1000; when there is no head contact, then the HPC shall not be measured or calculated but recorded as "No Head Contact."
- 5.2.3 The thorax performance criteria shall be:
 - (a) Rib Deflection Criterion (RDC) less than or equal to 42 mm;
 - (b) Soft Tissue Criterion (VC) less or equal to 1.0 m/sec.
- 5.2.4 The pelvis performance criterion shall be:
Pubic Symphysis Peak Force (PSPF) less than or equal to 6 kN.
- 5.2.5 The abdomen performance criterion shall be:
Abdominal Peak Force (APF) less than or equal to 2.5 kN internal force (equivalent to external force of 4.5 kN).

5.3 Particular Requirements

- 5.3.1 No door shall open during the test.
- 5.3.2 After the impact, it shall be possible without the use of tools to:
 - 5.3.2.1 open a sufficient number of doors provided for normal entry and exit of passengers, and if necessary tilt the seat-backs or seats to allow evacuation of all occupants;

- 5.3.2.2 release the dummy from the protective system;
- 5.3.2.3 remove the dummy from the vehicle;
- 5.3.3 no interior device or component shall become detached in such a way as noticeably to increase the risk of injury from sharp projections or jagged edges;
- 5.3.4 ruptures, resulting from permanent deformation are acceptable, provided these do not increase the risk of injury;
- 5.3.5 if there is continuous leakage of liquid from the fuel-feed installation after the collision, the rate of leakage shall not exceed 30 g/min; if the liquid from the fuel-feed system mixes with liquids from the other systems and the various liquids cannot easily be separated and identified, all the liquids collected shall be taken into account in evaluating the continuous leakage.

6 MODIFICATION OF THE VEHICLE TYPE

- 6.1 Any modification affecting the structure, the number and type of seats, the interior trim or fittings, or the position of the vehicle controls or of mechanical parts which might affect the energy-absorption capacity of the side of the vehicle, shall be brought to the notice of the testing agency granting approval. The testing agency may then either:
 - 6.1.1 consider that the modifications made are unlikely to have an appreciable adverse effect and that in any case the vehicle still complies with the requirements, or
 - 6.1.2 require a further test report from the testing agency responsible for conducting the tests;
 - 6.1.2.1 Any modification of the vehicle affecting the general form of the structure of the vehicle or any variation in the reference mass greater than 8% which in the judgment of the authority would have a marked influence on the results of the test shall require a repetition of the test as described in Annex 1.
 - 6.1.2.2 If the testing agency, after consultation with the vehicle manufacturer, considers that modifications to a vehicle type are insufficient to warrant a complete retest then a partial test may be used. This would be the case if the reference mass is not more than 8% different from the original vehicle or the number of front seats is unchanged. Variations of seat type or interior fittings need not automatically entail a full retest. An example of the approach to this problem is given in Annex 5.
- 6.2 Criteria for selection of worst case and extension of approvals

The purpose of the paragraph is to set out guidelines for selection of the worst case configuration among the many configurations being approved

within a vehicle type and to identify criteria for extensions of approval which may help the testing agency under 6.1. The guidelines are tabulated in Annex 6.

- 6.3 Any other parameter can be considered as criteria for extension of approval if it is mutually agreeable to the testing agency & the vehicle manufacturer.

ANNEX 1

(See 5.1)

COLLISION TEST PROCEDURE**1 INSTALLATIONS****1.1 Testing Ground**

The test area shall be large enough to accommodate the mobile deformable barrier propulsion system and to permit after-impact displacement of the vehicle impacted and installation of the test equipment. The part in which vehicle impact and displacement occur shall be horizontal, flat and uncontaminated, and representative of a normal, dry, uncontaminated road surface.

2 TEST CONDITIONS

2.1 The vehicle to be tested shall be stationary.

2.2 The mobile deformable barrier shall have the characteristics set out in Annex 2A to this standard. Requirements for the examination are given in the addendum to Annex 2A. The mobile deformable barrier shall be equipped with a suitable device to prevent a second impact on the struck vehicle.

Note: At the request of the manufacturer a mobile deformable barrier meeting the characteristics and requirements set out in Annex 2B is also acceptable for this test as an alternative. However, for the test, this barrier should only be used in combination with the side impact dummy (ES-2) defined in Annex 3B and its installation described in Annex 4B.

2.3 The trajectory of the mobile deformable barrier longitudinal median vertical plane shall be perpendicular to the longitudinal median vertical plane of the impacted vehicle.

2.4 The longitudinal vertical median plane of the mobile deformable barrier shall be coincident within ± 25 mm with a transverse vertical plane passing through the R Point of the front seat adjacent to the struck side of the tested vehicle. The horizontal median plane limited by the external lateral vertical planes of the front face shall be at the moment of impact within two planes determined before the test and situated 25 mm above and below the previously defined plane.

2.5 Instrumentation shall comply with ISO 6487:1987 unless otherwise specified in this standard.

2.6 The stabilized temperature of the test dummy at the time of the side impact test shall be $22 \pm 4^{\circ}\text{C}$.

3 TEST SPEED

- 3.1 The mobile deformable barrier speed at the moment of impact shall be 50 ± 1 km/h. This speed shall be stabilized at least 0.5 m before impact. Accuracy of measurement: 1%. However, if the test was performed at a higher impact speed and the vehicle met the requirements, the test shall be considered satisfactory.

4 STATE OF THE VEHICLE

4.1 General Specification

The test vehicle shall be representative of the series production, shall include all the equipment normally fitted and shall be in normal running order. Some components may be omitted or replaced by equivalent masses where this omission or substitution clearly has no effect on the results of the test.

4.2 Vehicle Equipment Specification

The test vehicle shall have all the optional arrangements or fittings likely to influence the results of the test.

4.3 Mass of the Vehicle

- 4.3.1 The vehicle to be tested shall have the reference mass as defined in paragraph 2.10 of this standard. The mass of the vehicle shall be adjusted to $\pm 1\%$ of the reference mass.
- 4.3.2 The fuel tank shall be filled with water to a mass equal to 90% of the mass of a full load of fuel as specified by the manufacturer.
- 4.3.3 All the other systems (brake, cooling, etc.) may be empty; in this case, the mass of the liquids shall be offset.
- 4.3.4 If the mass of the measuring apparatus on board of the vehicle exceeds the 25 kg allowed, it may be offset by reductions which have no noticeable effect on the results of the test.
- 4.3.5 The mass of the measuring apparatus shall not change each axle reference load by more than 5%, each variation not exceeding 20 kg.

5 PREPARATION OF THE VEHICLE

- 5.1 The side windows at least on the struck side shall be closed.
- 5.2 The doors shall be closed, but not locked.
- 5.3 The transmission shall be placed in neutral and the parking brake disengaged.

- 5.4 The comfort adjustments of the seats, if any, shall be adjusted to the position specified by the vehicle manufacturer.
- 5.5 The seat containing the dummy, and its elements, if adjustable, shall be adjusted as follows:
 - 5.5.1 The longitudinal adjustment device shall be placed with the locking device engaged in the position that is nearest to midway between the foremost and rearmost positions; if this position is between two notches, the rearmost notch shall be used.
 - 5.5.2 The head restraint shall be adjusted such that its top surface is level with the centre of gravity of the dummy's head; if this is not possible, the head restraint shall be in the uppermost position.
 - 5.5.3 Unless otherwise specified by the manufacturer, the seat-back shall be set such that the torso reference line of the three-dimensional H Point machine is set at an angle of $25 \pm 1^\circ$ towards the rear.
 - 5.5.4 All other seat adjustments shall be at the mid-point of available travel; however, height adjustment shall be at the position corresponding to the fixed seat, if the vehicle type is available with adjustable and fixed seats. If locking positions are not available at the respective mid-points of travel, the positions immediately rearward, down, or outboard of the mid-points shall be used. For rotational adjustments (tilt), rearward will be the adjustment direction which moves the head of the dummy rearwards. If the dummy protrudes outside the normal passenger volume, e.g. head into roof lining, then 1 cm clearance will be provided using: secondary adjustments, seat-back angle, or fore-aft adjustment in that order.
- 5.6 Unless otherwise specified by the manufacturer, the other front seats shall, if possible, be adjusted to the same position as the seat containing the dummy.
- 5.7 If the steering wheel is adjustable, all adjustments are positioned to their mid-travel locations.
- 5.8 Tyres shall be inflated to the pressure specified by the vehicle manufacturer.
- 5.9 The test vehicle shall be set horizontal about its roll axis and maintained by supports in that position until the side impact dummy is in place and after all preparatory work is complete.
- 5.10 The vehicle shall be at its normal attitude corresponding to the conditions set out in paragraph 4.3 above. Vehicles with suspension enabling their ground clearance to be adjusted shall be tested under the normal conditions of use at 50 km/h as defined by the vehicle manufacturer. This shall be assured by means of additional supports, if necessary, but such supports shall have no influence on the crash behaviour of the test vehicle during the impact.

6 SIDE IMPACT DUMMY AND ITS INSTALLATION

- 6.1 The side-impact dummy (EuroSid-1) shall comply with the specifications given in Annex 3A and be installed in the front seat on the impact side according to the procedure given in Annex 4A to this standard.

Note: At the request of the manufacturer the side impact dummy (ES-2) meeting the specifications given in Annex 3B and installed in the front seat on impact side as per procedure given in Annex 4B can also be used in this test. However when testing with this ES-2 dummy only the mobile deformable barrier meeting the characteristics and requirements set out in Annex 2B for the test shall be used.

- 6.2 The safety-belts or other restraint systems, which are specified for the vehicle, shall be used. Belts should be of an approved type & mounted on anchorages conforming to the relevant notified standards under Rule 125 of Central Motor Vehicle Rules, 1989.
- 6.3 The safety-belt or restraint system shall be adjusted to fit the dummy in accordance with the manufacturer's instructions; if there are no manufacturer's instructions, the height adjustment shall be set at middle position; if this position is not available, and the position immediately below shall be used.

7 MEASUREMENTS TO BE MADE ON THE SIDE IMPACT DUMMY

- 7.1 The readings of the following measuring devices are to be recorded.

7.1.1 Measurements in the Head of the Dummy

The resultant tri-axial acceleration referring to the head centre of gravity. The head channel instrumentation shall comply with ISO 6487:1987 with:

CFC: 1000 Hz, and
CAC: 150 g

7.1.2 Measurements in the Thorax of the Dummy

The three thorax rib deflection channels shall comply with
ISO 6487:1987
CFC: 1000 Hz
CAC: 60 mm

7.1.3 Measurements in the Pelvis of the Dummy

The pelvis force channel shall comply with ISO 6487:1987
CFC: 1000 Hz
CAC: 15 kN

7.1.4 Measurement in the Abdomen of the Dummy

The abdomen force channels shall comply with ISO 6487:1987

CFC: 1000 Hz

CAC: 5 kN

ANNEX 1 - APPENDIX 1

(See 5.2.1)

DETERMINATION OF PERFORMANCE DATA

The required results of the tests are specified in paragraph 5.2 of this standard.

1 HEAD PERFORMANCE CRITERION (HPC)

When head contact takes place this performance criterion is calculated for the total duration between the initial contact and the last instant of the final contact.

HPC is the maximum value of the expression:

$$(t_2 - t_1) \left[\frac{1}{t_2 - t_1} \int_{t_1}^{t_2} a \cdot dt \right]^{2.5}$$

where a is the resultant acceleration at the centre of gravity of the head in metres per second per second divided by 9.81 recorded versus time and filtered at channel frequency class 1000 Hz; t_1 and t_2 are any two times between the initial contact and the last instant of the final contact.

2 THORAX PERFORMANCE CRITERIA

2.1 Chest deflection: the peak chest deflection is the maximum value of deflection on any rib as determined by the thorax displacement transducers, filtered at channel frequency class 180 Hz.

2.2 Viscous criterion: the peak viscous response is the maximum value of VC on any rib which is calculated from the instantaneous product of the relative thorax compression related to the half thorax and the velocity of compression derived by differentiation of the compression, filtered at channel frequency class 180 Hz. For the purposes of this calculation the standard width of the half thorax rib cage is 140 mm.

$$VC = \max \left[\frac{D}{0.14} \cdot \frac{dD}{dt} \right]$$

where D (metres) = rib deflection

The calculation algorithm to be used is set out in Annex 1 - Appendix 2.

3 ABDOMEN PROTECTION CRITERION

The peak abdominal force is the maximum value of the sum of the three forces measured by transducers mounted 39 mm below the surface of the crash side, CFC 600 Hz.

4 PELVIS PERFORMANCE CRITERION

The pubic symphysis peak force (PSPF) is the maximum force measured by a load cell at the pubic symphysis of the pelvis, filtered at channel frequency class 600 Hz.

ANNEX 1 - APPENDIX 2

(See Annex 1 - Appendix 1 - 2.2)

**THE PROCEDURE FOR CALCULATING THE VISCOUS
CRITERION FOR SIDE IMPACT DUMMY**

The Viscous Criterion, VC, is calculated as the instantaneous product of the compression and the rate of deflection of the rib. Both are derived from the measurement of rib deflection. The rib deflection response is filtered once at Channel Frequency Class 180. The compression at time (t) is calculated as the deflection from this filtered signal expressed as the proportion of the half width of the side impact dummy chest, measured at the metal ribs (0.14 metres):

$$C_{(t)} = \frac{D_{(t)}}{0.14}$$

The rib deflection velocity at time (t) is calculated from the filtered deflection as:

$$V_{(t)} = \frac{8 [D_{(t+1)} - D_{(t-1)}] - [D_{(t+2)} - D_{(t-2)}]}{12\delta t}$$

where $D_{(t)}$ is the deflection at time (t) in metres and δt is the time interval in seconds between the measurements of deflection. The maximum value of δt shall be 1.25×10^{-4} seconds.

This calculation procedure is shown diagrammatically below:

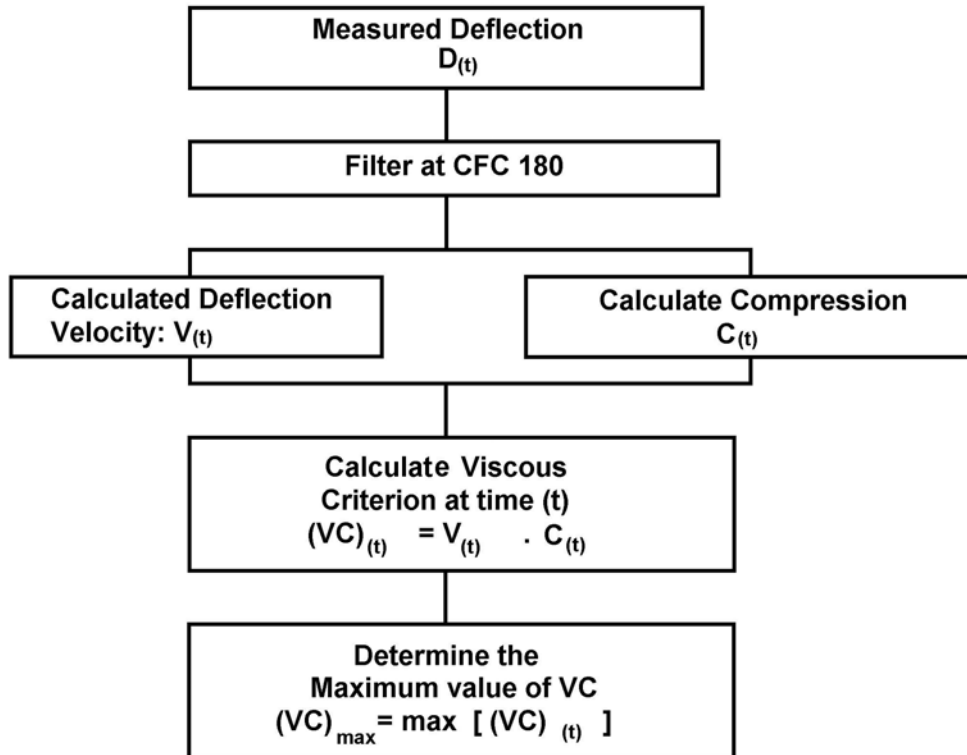

ANNEX 2 (A)
(See Annex 1 -2.2)

MOBILE DEFORMABLE BARRIER CHARACTERISTICS

1. CHARACTERISTICS OF THE BARRIER

- 1.1. The total mass shall be 950 ± 20 kg.
- 1.2. The front and rear track width of the trolley shall be $1\,500 \pm 10$ mm.
- 1.3. The wheel base of the trolley shall be $3\,000 \pm 10$ mm.
- 1.4. The centre of gravity shall be situated in the median longitudinal vertical plane within 10 mm, 1000 ± 30 mm behind the front axle and 500 ± 30 mm above the ground.
- 1.5. The distance between the front face of the impactor and the centre of gravity of the barrier shall be $2\,000 \pm 30$ mm.

2. CHARACTERISTICS OF THE IMPACTOR

2.1. Geometrical Characteristics

- 2.1.1. The impactor consists of six independent joined blocks whose forms, sizes and positioning are shown in Figure 1.
- 2.1.2. The deformable impact zone shall be $1\,500 \pm 10$ mm wide and 500 ± 5 mm high.
- 2.1.3. The ground clearance of the collision zone shall be 300 ± 5 mm measured in static conditions before impact.
- 2.1.4. There shall be six deformable elements, divided into two rows of three elements. All the elements shall have the same width (500 ± 5 mm) and the same height (250 ± 3 mm); the elements of the upper row shall be 440 ± 5 mm deep and those of the lower row 500 ± 5 mm deep.

2.2. Material Characteristics

The material of the impactor shall be an aluminium honeycomb. Other materials can be used if equal results as described in 2.3 have been proved to the satisfaction of the testing agency. In any case the type of impactor shall be indicated in the test report.

2.3. Deformation Characteristics

- 2.3.1. Deviation from the limits of the force-deflection corridors characterizing the rigidity of the impactor, as defined in this Annex, Figure 2, may be allowed provided that:

- 2.3.1.1 the deviation occurs after the beginning of the impact and before the deformation of the impactor is equal to 150 mm;
- 2.3.1.2 the deviation does not exceed 50% of the nearest instantaneous prescribed limit of the corridor;
- 2.3.1.3 each displacement corresponding to each deviation does not exceed 35 mm of the deflection, and the sum of these displacements does not exceed 70 mm (see Figure 2) and
- 2.3.1.4 the sum of the energy derived from deviating outside the corridor does not exceed 5% of the gross energy for that block.
- 2.3.2 Blocks 1 and 3 are identical. Their rigidity is such that their force- deflection curves fall within the hatched area of Figure 2, Graph 2a.
- 2.3.3 Blocks 5 and 6 are identical. Their rigidity is such that their force- deflection curves fall within the hatched area of Figure 2, Graph 2d.
- 2.3.4 The rigidity of block 2 is such that its force-deflection curve falls within the hatched area in Figure 2, Graph 2b.
- 2.3.5 The rigidity of block 4 is such that its force-deflection curve falls within the hatched area of Figure 2, Graph 2c.
- 2.3.6 The force-deflection curve of the impactor as a whole shall fall within the hatched area of Figure 2, Graph 2e.
- 2.3.7 The force-deflection curves are verified by a test detailed in the Addendum to this Annex, consisting of an impact of the assembly against a dynamometric barrier at 35 ± 2 km/h.
- 2.3.8 The dissipated energy ⁽¹⁾ against blocks 1 and 3 during the test shall equal 10 ± 2 kJ for each of these blocks.
- 2.3.9 The dissipated energy against blocks 5 and 6 shall equal 3.5 ± 1 kJ for each of these blocks.
- 2.3.10 The dissipated energy against block 4 shall equal 4 ± 1 kJ.
- 2.3.11 The dissipated energy against block 2 shall equal 14 ± 2 kJ.

⁽¹⁾ The amounts of energy indicated are the amounts of energy dissipated by the system when the extent to which the impactor is crushed is greatest.

- 2.3.12 The total dissipated energy during the impact shall equal 45 ± 5 kJ.
- 2.3.13 Impactor deformation measured after the test at level B (Figure 1) shall equal 330 ± 20 mm.

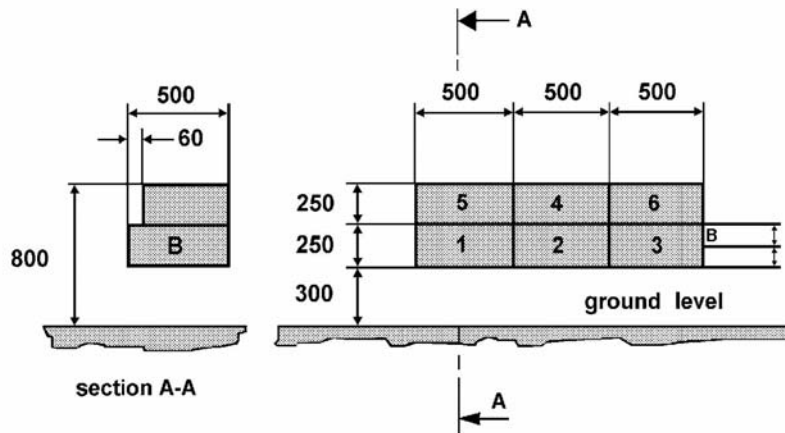
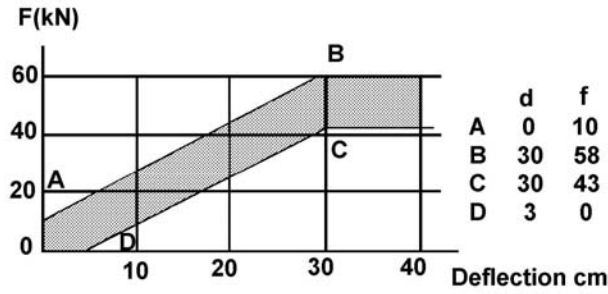
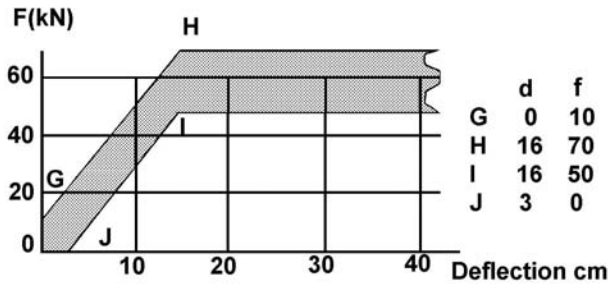

Figure 1

Design of the Mobile Deformable Barrier Impact



Graph 2a Blocks 1 and 3



Block 2 Graph 2b

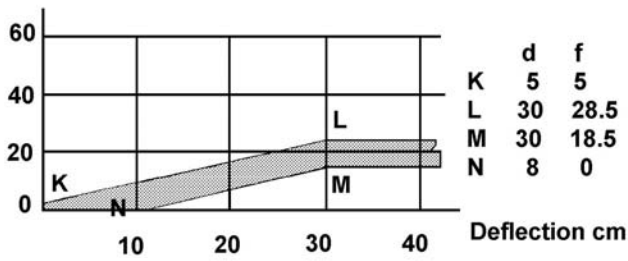

Graph 2c Block 4

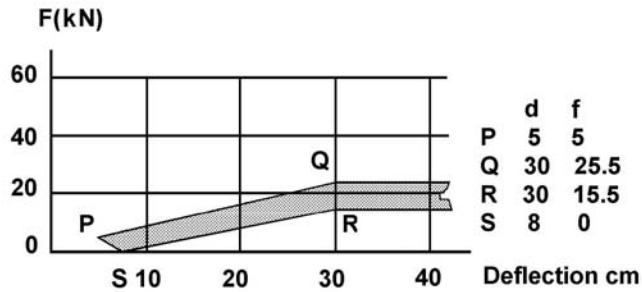

Graph 2d Blocks 5 and 6

Figure 2

Force-deflection Curves

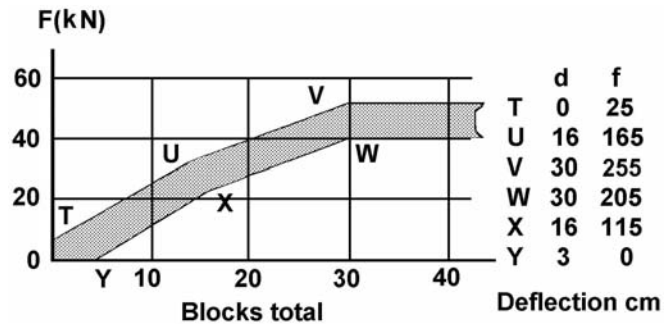

Graph 2d Figure 2 (continued)

Note: During the verification test, the loads measured on Blocks 1 and 3 and on Blocks 5 and 6 respectively shall not differ by more than 10% for a given deflection.

ANNEX 2 (A) ADDENDUM

(See Annex 2 (A) - 2.3.7)

**TEST TO VERIFY THE CHARACTERISTICS OF THE
MOBILE DEFORMABLE BARRIER****1. PURPOSE**

This addendum sets out the method for verifying the mobile deformable barrier. The test authority is responsible for the mobile deformable barrier meeting the specifications using a test against a dynamometric wall supported by a fixed rigid barrier.

2. INSTALLATION**2.1. Testing Ground**

The test area shall be large enough to accommodate the run-up track of the mobile deformable barrier, the rigid barrier and the technical equipment necessary for the test. The last part of the track, for at least 5 m before the rigid barrier, shall be horizontal, flat and smooth.

2.2. Fixed Rigid Barrier and Dynamometric Wall

2.2.1. The rigid barrier consists of a block of reinforced concrete not less than 3 m wide in front and not less than 1.5 m high. The thickness of the rigid barrier shall be such that it weighs at least 70 tonnes. The front face shall be vertical, perpendicular to the axis of the run-up track and covered with load cells capable of measuring the total load on each block of the mobile deformable barrier impactor at the moment of impact. The impact plate area centres shall align with those of the chosen mobile deformable barrier; their edges shall clear adjacent areas by 20 mm. Cell mounting and plate surfaces shall be in accordance with the requirements set out in the Annex to ISO 6487:1987. In cases where surface protection is added, it shall not degrade the transducer responses.

2.2.2. The rigid barrier shall be either anchored in the ground or placed on the ground with, if necessary, additional arresting devices to prevent its displacement. A rigid barrier with load cells having different characteristics but giving results that are at least equally conclusive may be used.

3. PROPULSION OF THE MOBILE DEFORMABLE BARRIER

At the moment of impact the mobile deformable barrier shall no longer be subject to the action of any additional steering or propelling device. It shall reach the obstacle on a course perpendicular to the collision barrier. Impact alignment shall be accurate to within 10 mm.

4 MEASURING INSTRUMENTS

4.1 Speed

The impact speed shall be 35 ± 2 km/h. The instrument used to record the speed on impact shall be accurate to within 1%.

4.2 Loads

Measuring instruments shall meet the specifications set forth in ISO 6487:1987

CFC for all blocks = 60 Hz,
CAC for blocks 1 and 3 = 120 kN,
CAC for blocks 4, 5 and 6 = 60 kN,
CAC for block 2 = 140 kN.

4.3. Acceleration

The acceleration in the longitudinal direction shall be measured at a place not subject to bending. The instrumentation shall comply with ISO 6487:1987 with the following specifications:

CFC: 1000 Hz (before integration),

CFC: 60 Hz (after integration),

CAC: 50 g

5 GENERAL SPECIFICATION OF BARRIER

5.1 The individual characteristics of each barrier shall comply with paragraph 1 of Annex 2(A) and be recorded.

6 GENERAL SPECIFICATION OF THE IMPACTOR TYPE

6.1 The suitability of an impactor type is confirmed when the outputs from the six load cells each produce signals complying with the requirements indicated in paragraph 2.2 of Annex 2(A) when recorded.

6.2 Impactors shall carry consecutive serial numbers including the date of manufacture.

ANNEX 2 (B)
(See Annex 1 - 2.2)

MOBILE DEFORMABLE BARRIER CHARACTERISTICS

1 CHARACTERISTICS OF THE MOBILE DEFORMABLE BARRIER

- 1.1 The mobile deformable barrier (MDB) includes both an impactor and a trolley.
- 1.2 The total mass shall be 950 ± 20 kg.
- 1.3 The centre of gravity shall be situated in the longitudinal median vertical plane within 10 mm, 1000 ± 30 mm behind the front axle and 500 ± 30 mm above the ground.
- 1.4 The distance between the front face of the impactor and the centre of gravity of the barrier shall be 2000 ± 30 mm
- 1.5 The ground clearance of the collision impactor shall be 300 ± 5 mm measured in static conditions from the lower edge of the lower front plate before the impact.
- 1.6 The front and rear track width of the trolley shall be 1500 ± 10 mm.
- 1.7 The wheel base of the trolley shall be 3000 ± 10 mm.

2 CHARACTERISTICS OF THE IMPACTOR

The impactor consists of six single blocks of aluminium honeycomb, which have been processed in order to give a progressively increasing level of force with increasing deflection (see paragraph 2.1). Front and rear aluminium plates are attached to the aluminium honeycomb blocks.

2.1 Honeycomb Blocks

2.1.1 Geometrical Characteristics

- 2.1.1.1 The impactor consists of 6 joined zones whose forms and positioning are shown in Figures 1 and 2. The zones are defined as 500 ± 5 mm x 250 ± 3 mm in Figures 1 and 2. The 500 mm should be in the W direction and the 250 mm in the L direction of the aluminium honeycomb construction (see Figure 3).
- 2.1.1.2 The impactor is divided into 2 rows. The lower row shall be 250 ± 3 mm high, and 500 ± 2 mm deep after pre-crush (see paragraph 2.1.2) and deeper than the upper row by 60 ± 2 mm.

- 2.1.1.3 The blocks shall be centered on the six zones defined in Figure 1 and each block (including incomplete cells) should cover completely the area defined for each zone.
- 2.1.2 Pre-crush
 - 2.1.2.1 The pre-crush shall be performed on the surface of the honeycomb to which the front sheets are attached.
 - 2.1.2.2 Blocks 1, 2 and 3 should be crushed by 10 ± 2 mm on the top surface prior to testing to give a depth of 500 ± 2 mm (Figure 2).
 - 2.1.2.3 Blocks 4, 5 and 6 should be crushed by 10 ± 2 mm on the top surface prior to testing to give a depth of 440 ± 2 mm.
- 2.1.3 Material Characteristics
 - 2.1.3.1 The cell dimensions shall be $19 \text{ mm} \pm 10\%$ for each block (see Figure 4).
 - 2.1.3.2 The cells shall be made of 3003 aluminium for the upper row.
 - 2.1.3.3 The cells shall be made of 5052 aluminium for the lower row.
 - 2.1.3.4 The aluminium honeycomb blocks should be processed such that the force deflection-curve when statically crushed (according to the procedure defined in paragraph 2.1.4) is within the corridors defined for each of the six blocks in Appendix 1 to this Annex. Moreover, the processed honeycomb material used in the honeycomb blocks to be used for constructing the barrier should be cleaned in order to remove any residue that may have been produced during the processing of the raw honeycomb material.
 - 2.1.3.5 The mass of the blocks in each batch shall not differ by more than 5% of the mean block mass for that batch.
- 2.1.4 Static Tests
 - 2.1.4.1 A sample taken from each batch of processed honeycomb core shall be tested according to the static test procedure described in paragraph 5.
 - 2.1.4.2 The force-compression for each block tested shall lie within the force deflection corridors defined in Appendix 1. Static force-deflection corridors are defined for each block of the barrier.
- 2.1.5 Dynamic Test
 - 2.1.5.1 The dynamic deformation characteristics, when impacted according to the protocol described in paragraph 6.

- 2.1.5.2 Deviation from the limits of the force-deflection corridors characterizing the rigidity of the impactor - as defined in Appendix 2 - may be allowed provided that:
- 2.1.5.2.1 The deviation occurs after the beginning of the impact and before the deformation of the impactor is equal to 150 mm;
 - 2.1.5.2.2 The deviation does not exceed 50% of the nearest instantaneous prescribed limit of the corridor;
 - 2.1.5.2.3 Each deflection corresponding to each deviation does not exceed 35 mm of deflection and the sum of these deflections does not exceed 70 mm (see Appendix 2 to this Annex);
 - 2.1.5.2.4 The sum of energy derived from deviating outside the corridor does not exceed 5% of the gross energy for that block.
- 2.1.5.3 Blocks 1 and 3 are identical. Their rigidity is such that their force deflection curves fall between corridors of Figure 2a.
- 2.1.5.4 Blocks 5 and 6 are identical. Their rigidity is such that their force deflection curves fall between corridors of Figure 2d.
- 2.1.5.5 The rigidity of Block 2 is such that its force deflection curve falls between corridors of Figure 2c.
- 2.1.5.6 The rigidity of Block 4 is such that its force deflection curve falls between corridors of Figure 2b.
- 2.1.5.7 The force-deflection of the impactor as a whole shall fall between corridors of Figure 2e.
- 2.1.5.8 The force-deflection curves shall be verified by a test detailed in Annex 2(B), paragraph 6, consisting of an impact of the barrier against a dynamometric wall at 35 ± 0.5 km/h.
- 2.1.5.9 The dissipated energy ⁽¹⁾ against Blocks 1 and 3 during the test shall be equal to 9.5 ± 2 kJ for these blocks.
- 2.1.5.10 The dissipated energy against Blocks 5 and 6 during the test shall be equal to 3.5 ± 1 kJ for these blocks.
- 2.1.5.11 The dissipated energy against Block 4 shall be equal to 4 ± 1 kJ
- 2.1.5.12 The dissipated energy against Block 2 shall be equal to 15 ± 2 kJ.
- 2.1.5.13 The dissipated total energy during the impact shall be equal to 45 ± 3 kJ.

(1) the amounts of energy indicated are the amounts of energy dissipated by the system when the extent to which the impactor crushed is greatest.

2.1.5.14 The maximum impactor deformation from the point of first contact, calculated from integration of the accelerometers according to paragraph 6.6.3, shall be equal to 330 ± 20 mm.

2.1.5.15 The final residual static impactor deformation measured after the dynamic test at level B (Figure 2) shall be equal to 310 ± 20 mm.

2.2. Front Plates

2.2.1. Geometrical Characteristics

2.2.1.1 The front plates are 1500 ± 1 mm wide and 250 ± 1 mm high. The thickness is 0.5 ± 0.06 mm.

2.2.1.2 When assembled the overall dimensions of the impactor (defined in Figure 2) shall be: 1500 ± 2.5 mm wide and 500 ± 2.5 mm high.

2.2.1.3 The upper edge of the lower front plate and the lower edge of the upper front plate should be aligned within 4 mm.

2.2.2. Material Characteristics

2.2.2.1 The front plates are manufactured from aluminium of series AlMg₂ to AlMg₃ with elongation $\geq 12\%$, and a UTS ≥ 175 N/mm².

2.3. Back Plate

2.3.1. Geometric Characteristics

2.3.1.1 The geometric characteristics shall be according to Figures 5 and 6.

2.3.2. Material Characteristics

2.3.2.1 The back plate shall consist of a 3 mm aluminium sheet. The back plate shall be manufactured from aluminium of series AlMg₂ to AlMg₃ with hardness between 50 and 65 HBS. This plate shall be perforated with holes for ventilation: the location, the diameter and pitch are shown in Figures 5 and 7.

2.4. Location of the Honeycomb Blocks

2.4.1 The honeycomb blocks shall be centered on the perforated zone of the back plate (Figure 5).

2.5. Bonding

2.5.1 For both the front and the back plates, a maximum of 0.5 kg/m^2 shall be applied evenly directly over the surface of the front plate, giving a maximum film thickness of 0.5 mm. The adhesive to be used throughout should be a two-part polyurethane (such as Ciba Geigy XB5090/1 resin with XB5304 hardener) or equivalent.

- 2.5.2 For the back plate the minimum bonding strength shall be 0.6 MPa, (87 psi), tested according to paragraph 2.5.3.
- 2.5.3 Bonding Strength Tests:
 - 2.5.3.1 Flatwise tensile testing is used to measure bond strength of adhesives according to ASTM C297-61.
 - 2.5.3.2 The test piece should be 100 mm x 100 mm and 15 mm deep, bonded to a sample of the ventilated back plate material. The honeycomb used should be representative of that in the impactor, i.e. chemically etched to an equivalent degree as that near to the back plate in the barrier but without pre-crushing.

2.6 Traceability

Impactors shall carry consecutive serial numbers which are stamped, etched or otherwise permanently attached, from which the batches for the individual blocks and the date of manufacture can be established.

2.7 Impactor Attachment

- 2.7.1 The fitting on the trolley shall be according to Figure 8. The fitting will use six M8 bolts, and nothing shall be larger than the dimensions of the barrier in front of the wheels of the trolley. Appropriate spacers shall be used between the lower back plate flange and the trolley face to avoid bowing of the back plate when the attachment bolts are tightened.

3 VENTILATION SYSTEM

- 3.1. The interface between the trolley and the ventilation system should be solid, rigid and flat. The ventilation device is part of the trolley and not of the impactor as supplied by the manufacturer. Geometrical characteristics of the ventilation device shall be according to Figure 9.

3.2. Ventilation Device Mounting Procedure

- 3.2.1. Mount the ventilation device to the front plate of the trolley;
- 3.2.2. Ensure that a 0.5 mm thick gauge cannot be inserted between the ventilation device and the trolley face at any point. If there is a gap greater than 0.5 mm, the ventilation frame will need to be replaced or adjusted to fit without a gap of > 0.5 mm.
- 3.2.3. Dismount the ventilation device from the front of the trolley;
- 3.2.4. Fix a 1.0 mm thick layer of cork to the front face of the trolley;
- 3.2.5. Remount the ventilation device to the front of the trolley and tighten to exclude air gaps.

4 CONFORMITY OF PRODUCTION

- 4.1 The conformity of production procedures shall comply with those set out in the Agreement, Appendix (E/ECE/324E/ECE/TRANS/505/Rev.2), with the following requirements:
 - 4.1.1 The manufacturer shall be responsible for the conformity of production Procedures and for that purpose shall in particular:
 - 4.1.2 Ensure the existence of effective procedures so that the quality of the Products can be inspected,
 - 4.1.3 Have access to the testing equipment needed to inspect the conformity of each product,
 - 4.1.4 Ensure that the test results are recorded and that the documents remain available for a time period of 10 years after the tests,
 - 4.1.5 Demonstrate that the samples tested are a reliable measure of the performance of the batch (examples of sampling methods according to batch production are given below).
 - 4.1.6 Analyse results of tests in order to verify and ensure the stability of the barrier characteristics, making allowance for variations of an industrial production, such as temperature, raw materials quality, time of immersion in chemical, chemical concentration, neutralisation etc, and the control of the processed material in order to remove any residue from the processing,
 - 4.1.7 Ensure that any set of samples or test pieces giving evidence of non-conformity gives rise to a further sampling and test. All the necessary steps shall be taken to restore conformity of the corresponding production.
- 4.2 The manufacturer's level of certification shall be at least ISO 9002 standard.
- 4.3 Minimum conditions for the control of production: the holder of an agreement will ensure the control of conformity following the methods hereunder described.
- 4.4 **Examples of Sampling According to Batch**
 - 4.4.1 If several examples of one block type are constructed from one original block of aluminium honeycomb and are all treated in the same treatment bath (parallel production), one of these examples could be chosen as the sample, provided care is taken to ensure that the treatment is evenly applied to all blocks. If not, it may be necessary to select more than one sample.

- 4.4.2 If a limited number of similar blocks (say three to twenty) are treated in the same bath (serial production), then the first and last block treated in a batch, all of which are constructed from the same original block of aluminium honeycomb, should be taken as representative samples. If the first sample complies with the requirements but the last does not, it may be necessary to take further samples from earlier in the production until a sample that does comply is found. Only the blocks between these samples should be considered to be approved.
- 4.4.3 Once experience is gained with the consistency of production control, it may be possible to combine both sampling approaches, so that more than one groups of parallel production can be considered to be a batch provided samples from the first and last production groups comply.

5 STATIC TESTS

- 5.1 One or more samples (according to the batch method) taken from each batch of processed honeycomb core shall be tested, according to the following test procedure:
- 5.2 The sample size of the aluminium honeycomb for static tests shall be the size of a normal block of the impactor, that is to say 250 mm x 500 mm x 440 mm for top row and 250 mm x 500 mm x 500 mm for the bottom row.
- 5.3 The samples should be compressed between two parallel loading plates which are at least 20 mm larger than the block cross section.
- 5.4 The compression speed shall be 100 mm per minute, with a tolerance of 5%.
- 5.5 The data acquisition for static compression shall be sampled at a minimum of 5 Hz.
- 5.6 The static test shall be continued until the block compression is at least 300 mm for blocks 4 to 6 and 350 mm for blocks 1 to 3.

6 DYNAMIC TESTS

For every 100 barrier faces produced, the manufacturer shall make one dynamic test against a dynamometric wall supported by a fixed rigid barrier, according to the method described below.

6.1 Installation

6.1.1 Testing Ground

- 6.1.1.1 The test area shall be large enough to accommodate the run-up-track of the mobile deformable barrier, the rigid barrier and the technical equipment necessary for the test. The last part of the track, for at least 5 metres before the rigid barrier, shall be horizontal, flat and smooth.

6.1.2 Fixed Rigid Barrier and Dynamometric Wall

- 6.1.2.1 The rigid wall shall consist of a block of reinforced concrete not less than 3 metres wide and not less than 1.5 metres high. The thickness of the rigid wall shall be such that it weighs at least 70 tonnes.
- 6.1.2.2 The front face shall be vertical, perpendicular to the axis of the run-up-track and equipped with six load cell plates, each capable of measuring the total load on the appropriate block of the mobile deformable barrier impactor at the moment of impact. The load cell impact plate area centres shall align with those of the six impact zones of the mobile deformable barrier face. Their edges shall clear adjacent areas by 20 mm such that, within the tolerance of impact alignment of the MDB, the impact zones will not contact the adjacent impact plate areas. Cell mounting and plate surfaces shall be in accordance with the requirements set out in the Annex to standard ISO 6487:1987.
- 6.1.2.3 Surface protection, comprising a plywood face (thickness: 12 ± 1 mm), is added to each load cell plate such that it shall not degrade the transducer responses.
- 6.1.2.4 The rigid wall shall be either anchored in the ground or placed on the ground with, if necessary, additional arresting devices to limit its deflection. A rigid wall (to which the load cells are attached) having different characteristics but giving results that are at least equally conclusive may be used.

6.2 Propulsion of the Mobile Deformable Barrier

- 6.2.1 At the moment of impact the mobile deformable barrier shall no longer be subject to the action of any additional steering or propelling device. It shall reach the obstacle on a course perpendicular to the front surface of the dynamometric wall. Impact alignment shall be accurate to within 10mm.

6.3 Measuring Instruments

6.3.1 Speed

The impact speed shall be 35 ± 0.5 km/h the instrument used to record the speed on impact shall be accurate to within 0.1%.

6.3.2 Loads

Measuring instruments shall meet the specifications set forth in

ISO 6487:1987

CFC for all Blocks:	60 Hz
CAC for Blocks 1 and 3:	200 kN
CAC for Blocks 4, 5 and 6:	100 kN
CAC for Block 2:	200 kN

6.3.3 Acceleration

- 6.3.3.1 The acceleration in the longitudinal direction shall be measured at three separate positions on the trolley, one centrally and one at each side, at places not subject to bending.
- 6.3.3.2 The central accelerometer shall be located within 500 mm of the location of the centre of gravity of the MDB and shall lie in a vertical longitudinal plane which is within ± 10 mm of the centre of gravity of the MDB.
- 6.3.3.3 The side accelerometers shall be at the same height as each other ± 10 mm and at the same distance from the front surface of the MDB ± 20 mm.
- 6.3.3.4 The instrumentation shall comply with ISO 6487:1987 with the following specifications:
 - CFC1000 Hz (before integration)
 - CAC50g

6.4 General Specifications of Barrier

- 6.4.1 The individual characteristics of each barrier shall comply with paragraph 1 of this Annex and shall be recorded.

6.5 General Specifications of the Impactor

- 6.5.1 The suitability of an impactor as regards the dynamic test requirements shall be confirmed when the outputs from the six load cell plates each produce signals complying with the requirements indicated in this Annex.
- 6.5.2 Impactors shall carry consecutive serial numbers which are stamped, etched or otherwise permanently attached, from which the batches for the individual blocks and the date of manufacture can be established.

6.6 Data Processing Procedure

- 6.6.1 Raw data: At time $T = T_0$, all offsets should be removed from the data. The method by which offsets are removed shall be recorded in the test report.
- 6.6.2 Filtering
 - 6.6.2.1 The raw data will be filtered prior to processing/calculations.
 - 6.6.2.2 Accelerometer data for integration will be filtered to CFC 180, ISO 6487:1987.
 - 6.6.2.3 Accelerometer data for impulse calculations will be filtered to CFC 60, ISO 6487:1987.

- 6.6.2.4 Load cell data will be filtered to CFC 60, ISO 6487:1987.
- 6.6.3 Calculation of MDB Face Deflection
 - 6.6.3.1 Accelerometer data from all three accelerometers individually (after filtering at CFC 180), will be integrated twice to obtain deflection of the barrier deformable element.
 - 6.6.3.2 The initial conditions for deflection are:
 - 6.6.3.2.1 Velocity - impact velocity (from speed measuring device).
 - 6.6.3.2.2 Deflection = 0.
 - 6.6.3.3 The deflection at the left hand side, mid-line and right hand side of the mobile deformable barrier will be plotted with respect to time.
 - 6.6.3.4 The maximum deflection calculated from each of the three accelerometers should be within 10 mm. If it is not the case, then the outlier should be removed and difference between the deflection calculated from the remaining two accelerometers checked to ensure that it is within 10 mm.
 - 6.6.3.5 If the deflections as measured by the left hand side, right hand side and mid-line accelerometers are within 10 mm, then the mean acceleration of the three accelerometers should be used to calculate the deflection of the barrier face.
 - 6.6.3.6 If the deflection from only two accelerometers meets the 10 mm requirement, then the mean acceleration from these two accelerometers should be used to calculate the deflection for the barrier face.
 - 6.6.3.7 If the deflections calculated from all three accelerometers (left hand side, right hand side and mid-line) are NOT within the 10 mm requirement, then the raw data should be reviewed to determine the causes of such large variation. In this case the individual test house will determine which accelerometer data should be used to determine mobile deformable barrier deflection or whether none of the accelerometer readings can be used, in which case, the certification test shall be repeated. A full explanation should be given in the test report.
 - 6.6.3.8 The mean deflection-time data will be combined with the load cell wall force-time data to generate the force-deflection result for each block.
- 6.6.4 Calculation of Energy

The absorbed energy for each block and for the whole MDB face should be calculated up to the point of peak deflection of the barrier.

$$E_n = \int_{t_0}^{t_1} F_n \cdot ds_{\text{mean}}$$

where:

t_0 is the time of first contact

t_1 is the time where the trolley comes to rest, i.e. where $u = 0$.

s is the deflection of the trolley deformable element calculated according to paragraph 6.6.3

6.6.5 Verification of Dynamic Force Data

6.6.5.1 Compare the total impulse, I , calculated from the integration of the total force over the period of contact, with the momentum change over that period ($M \cdot \Delta V$).

6.6.5.2 Compare the total energy change to the change in kinetic energy of the MDB, given by:

$$E_k = 1/2 * M V_i^2$$

where V_i is the impact velocity and M the whole mass of the MDB.

If the momentum change ($M \cdot \Delta V$) is not equal to the total impulse (I) 5%, or if the total energy absorbed (ΣE_n) is not equal to the kinetic energy, $E_k \pm 5\%$, then the test data shall be examined to determine the cause of this error.

DESIGN OF IMPACTOR ⁽¹⁾

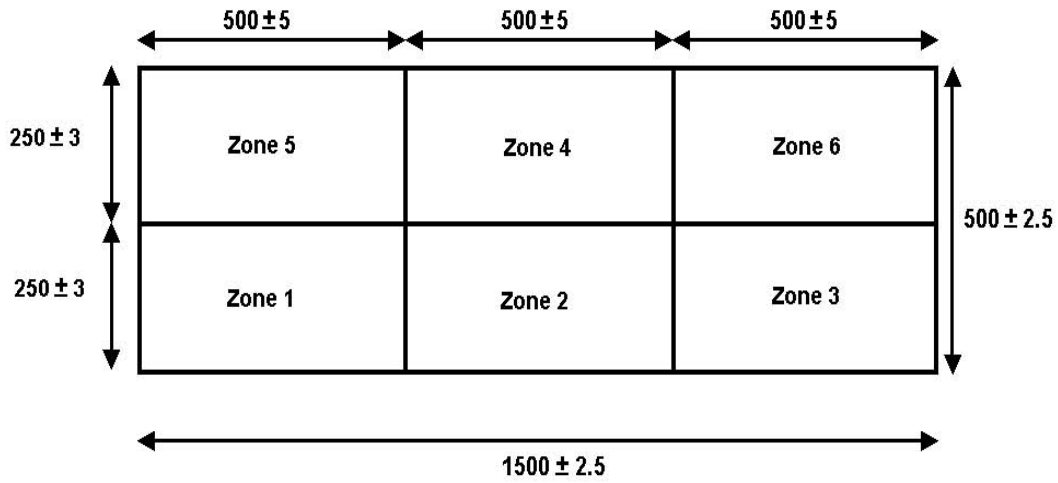

Figure 1

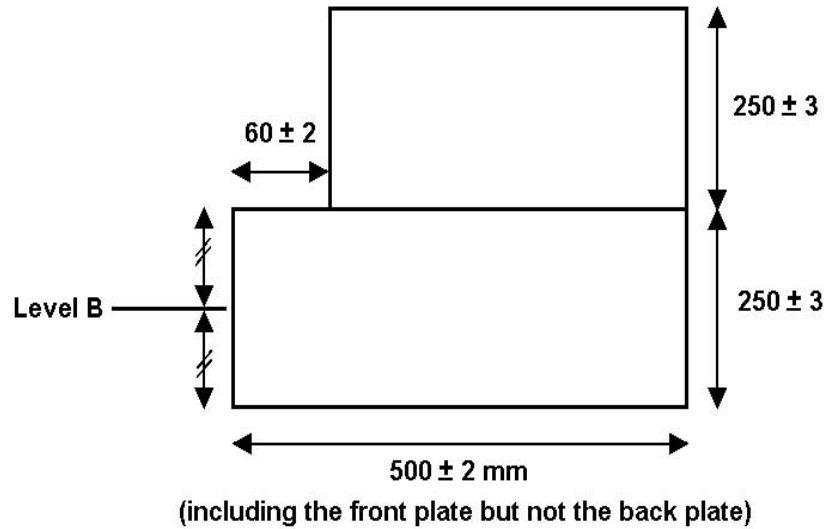

Figure 2

(1) All dimensions are in mm. The tolerances on the dimensions of the blocks allow for the difficulties of measuring cut aluminium honeycomb. The tolerance on the overall dimension of the impactor is less than that for the individual blocks since the honeycomb blocks can be adjusted, with overlap if necessary, to maintain a more closely defined impact face dimension.

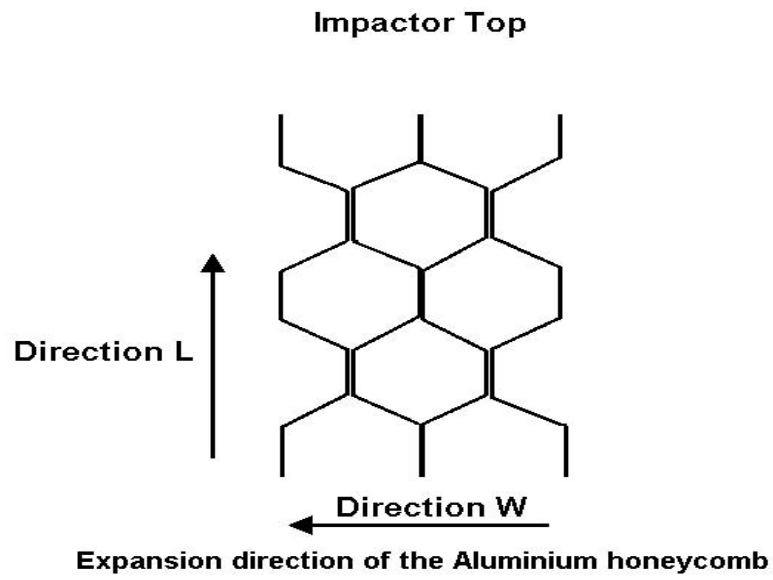

Figure 3

Aluminium Honeycomb Orientation

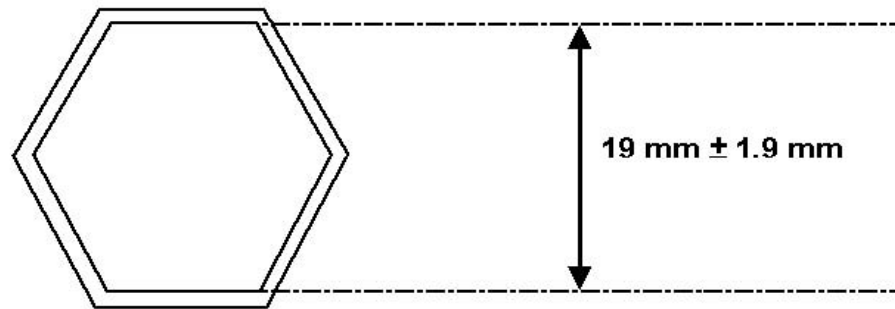

Figure 4

Dimension of Aluminium Honeycomb Cells

DESIGN OF THE BACK PLATE

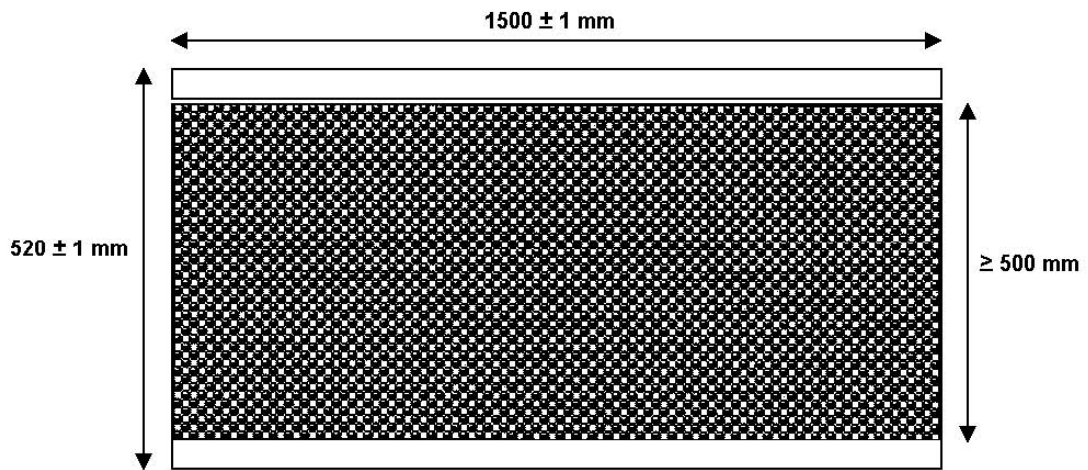

Figure 5

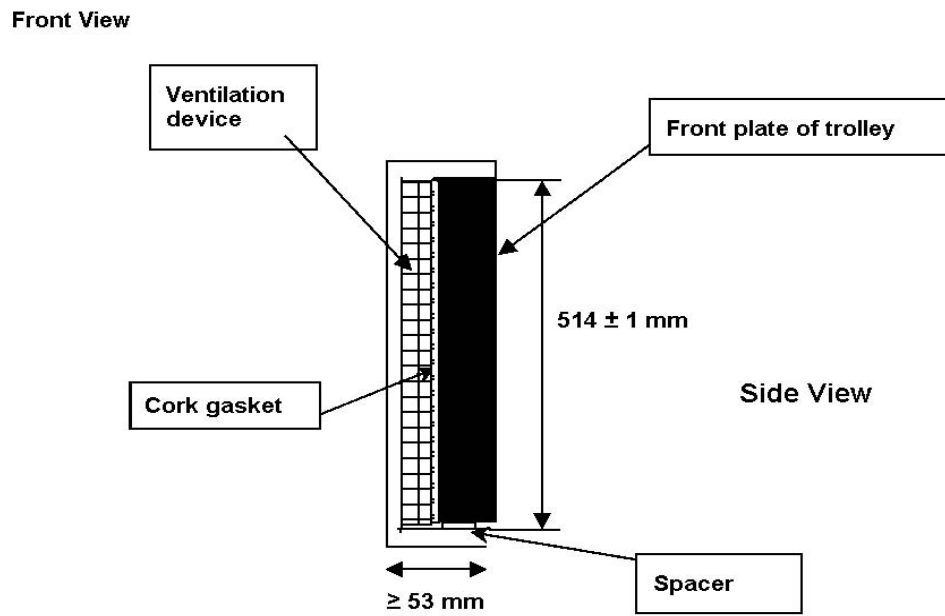

Figure 6

Attachment of Backplate to Ventilation Device and Trolley Face Plate

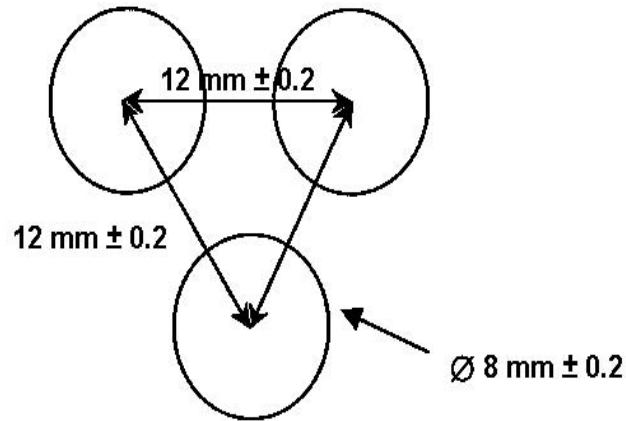
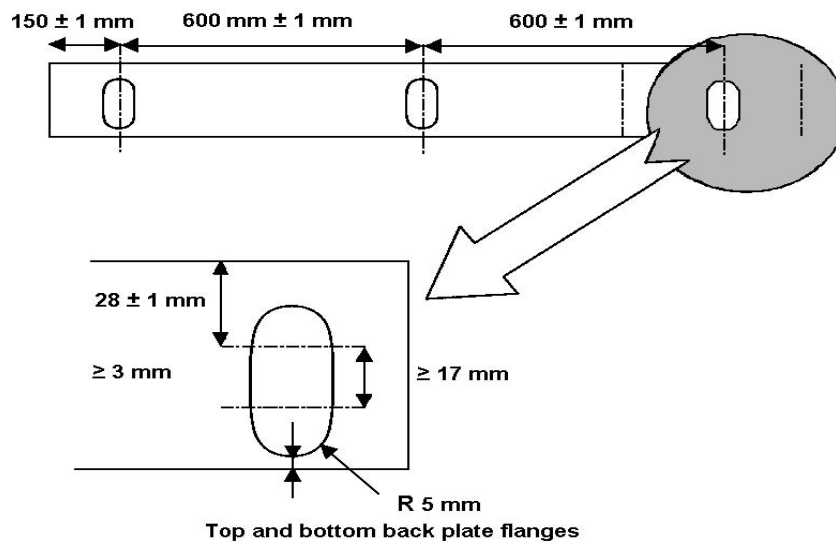

Figure 7

Staggered Pitch for the Back Plate Ventilation Holes



Note: The attachment holes in the bottom flange may be opened to slots, as shown below, for ease of attachment provided sufficient grip can be developed to avoid detachment during the whole impact test.

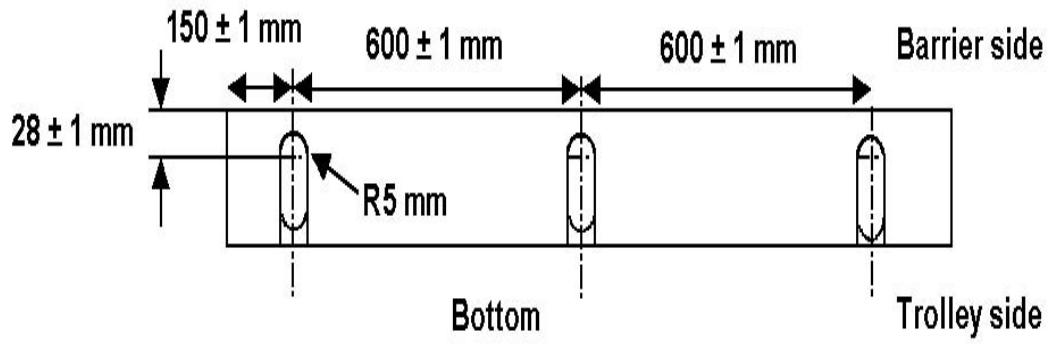

Figure 8

VENTILATION FRAME

The ventilation device is a structure made of a plate that is 5 mm thick and 20 mm wide. Only the vertical plates are perforated with nine 8 mm holes in order to let air circulate horizontally.

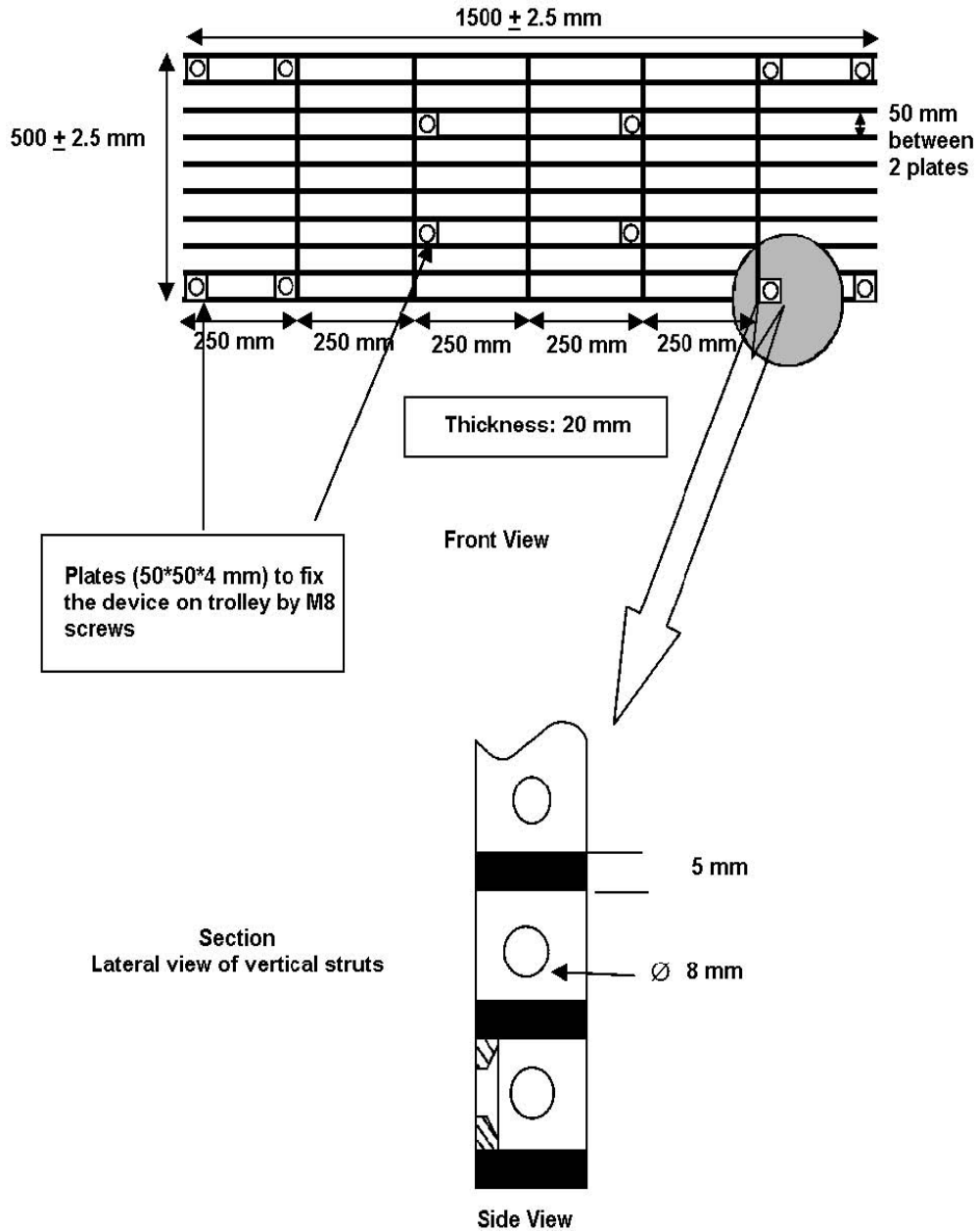

FIGURE-9

ANNEX 2 (B) - APPENDIX 1

(See Annex 2(B) - 2.1.3.4)

FORCE-DEFLECTION CURVES FOR STATIC TESTS

Blocks 1 & 3

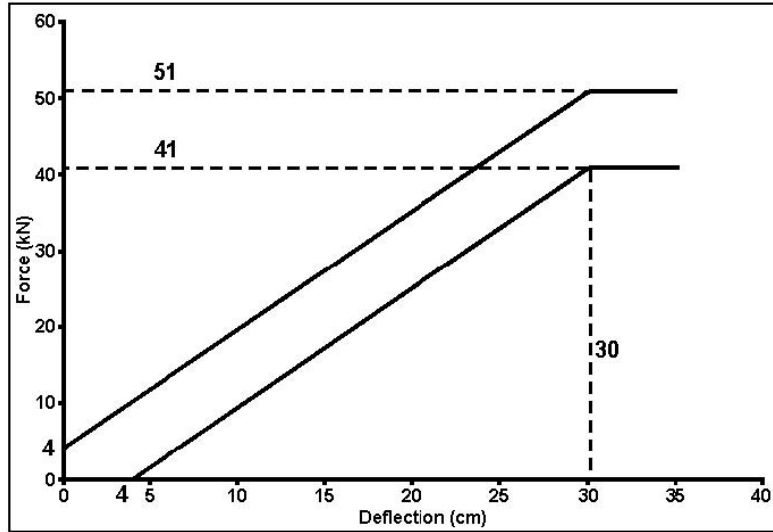

Figure 1a

Block 2

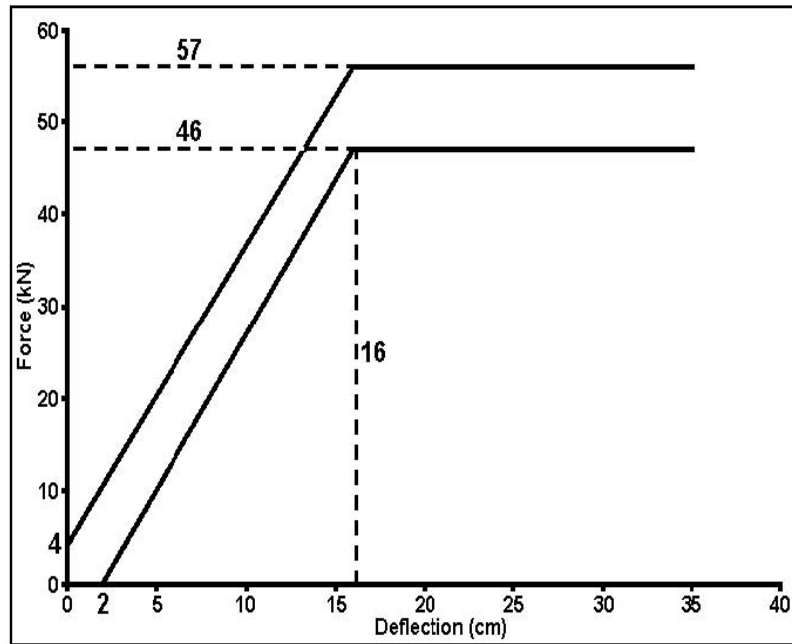

Figure 1b

Block 4

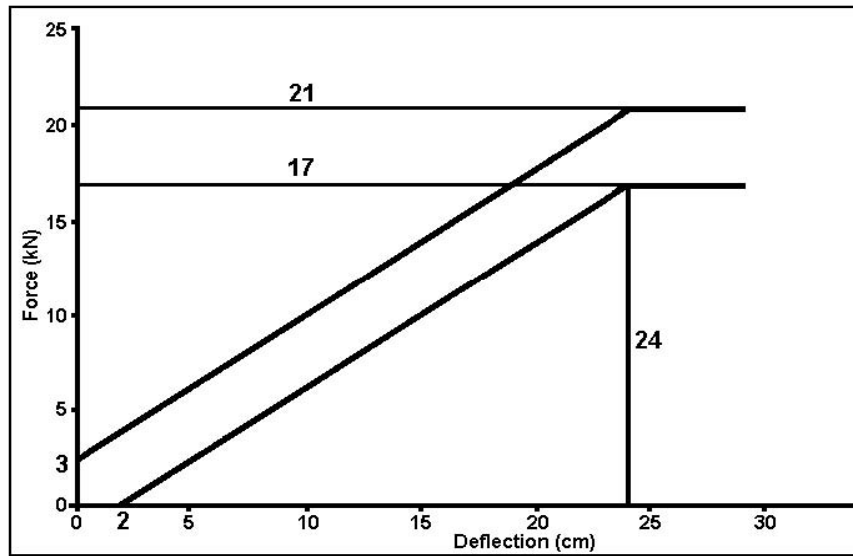

Figure 1c

Blocks 5 & 6

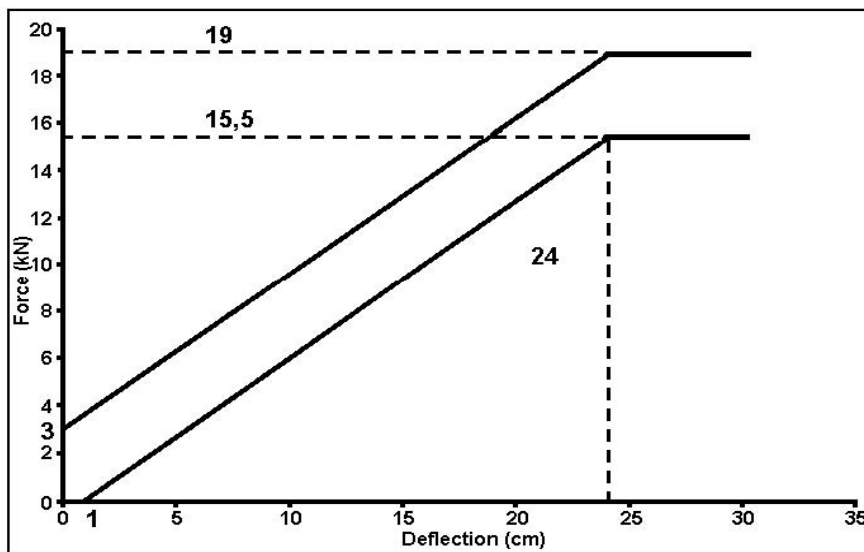

Figure 1d

ANNEX 2 (B) - APPENDIX 2

(See Annex 2(B) -2.1.5.2.3)

FORCE-DEFLECTION CURVES FOR DYNAMIC TESTS

Blocks 1 & 3

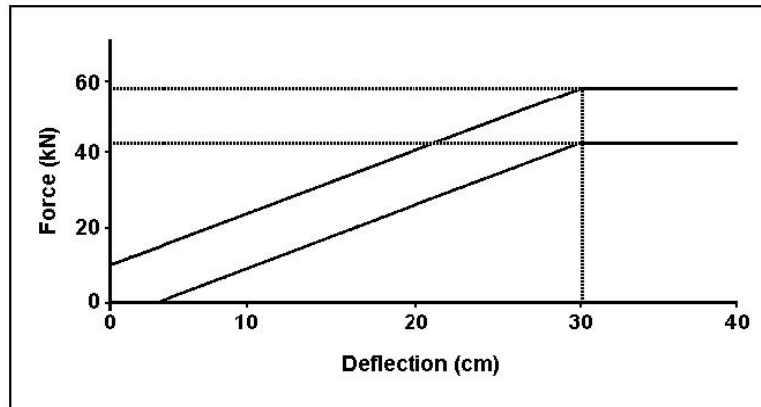

Figure 2 a

Block 4

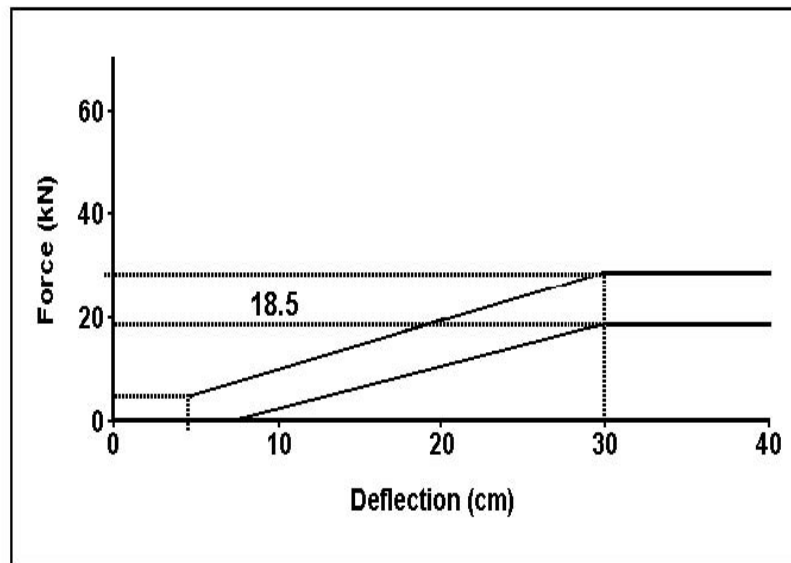

Figure 2b

Block 2

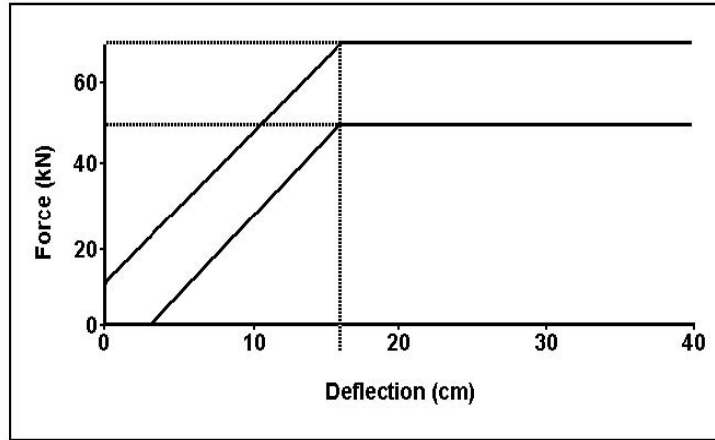

Figure 2c

Blocks 5 & 6

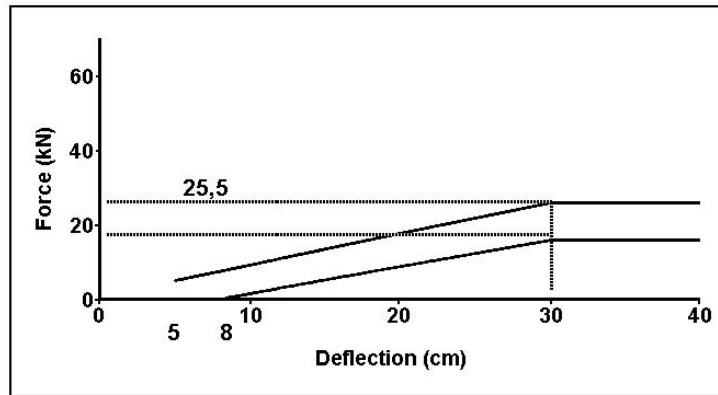

Figure 2d

Blocks total

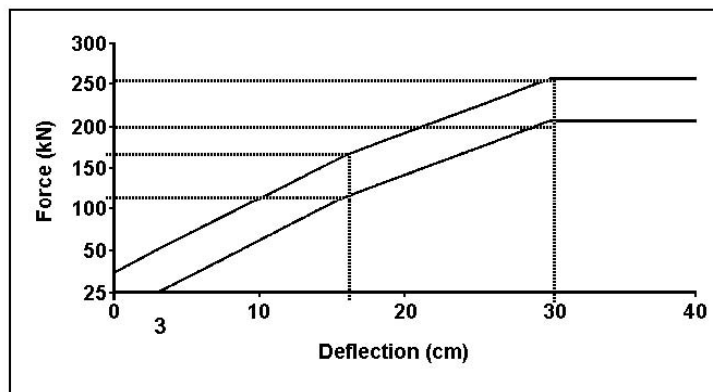

Figure 2e

ANNEX 3 (A)
(See Annex 1 – 6.1)

TECHNICAL DESCRIPTION OF THE SIDE IMPACT DUMMY

1. GENERAL

- 1.1. The dimensions and masses of the side impact dummy represent a 50th percentile adult male, without lower arms.
- 1.2. The side impact dummy consists of a metal and plastic skeleton covered by flesh-simulating rubber, plastic and foam.
- 1.3. The side impact dummy prescribed in this standard, including the instrumentation and calibration, is described in technical drawings and a user's manual⁽¹⁾

2. CONSTRUCTION

- 2.1. For an overview of the side impact dummy see Figure 1 and Table 1 of this Annex.
- 2.2. **Head**
 - 2.2.1. The head is shown as Part No 1 in Figure 1 of this Annex.
 - 2.2.2. The head consists of an aluminium shell covered by a pliable vinyl skin. The interior of the shell is a cavity accommodating tri-axial accelerometers and ballast.
- 2.3. **Neck**
 - 2.3.1. The neck is shown as Part No 2 in Figure 1 of this Annex.
 - 2.3.2. The neck consists of a head/neck interface piece, a neck/thorax interface piece and a central section that links the two interfaces to one another.
 - 2.3.3. The head/neck interface piece (Part No 2a) and the neck/thorax interface piece (Part No 2c) both consist of two aluminium discs linked together by means of a half spherical screw and eight rubber buffers.
 - 2.3.4. The cylindrical central section (Part No 2b) is made of rubber.

(1) Until publication of appropriate ISO standards these documents (Eurosid-1 user's manual, dated November 1990) can be obtained from TNO Road Vehicles Research Institute, PO Box 6033, 2600 JA Delft, Schoenmakerstraat 97, 2628 VK Delft, The Netherlands.

- 2.3.5 The neck is mounted on the neck-bracket, shown as Part No 3 in Figure 1 of this Annex.
- 2.3.6 The angle between the two faces of the neck-bracket is 25°. Because the shoulder block is inclined 5° backwards, the resulting angle between the neck and torso is 20°.
- 2.4 **Shoulder**
- 2.4.1 The shoulder is shown as Part No 4 in Figure 1 of this Annex.
- 2.4.2 The shoulder consists of a shoulder block, two clavicles and a shoulder cap.
- 2.4.3 The shoulder block (Part No 4a) consists of an aluminium spacer block, an aluminium plate on top and an aluminium plate on the bottom of the spacer block.
- 2.4.4 The clavicles (Part No 4b) are made of polypropylene. The clavicles are held back in their neutral position by two elastic cords (Part No 4c) which are clamped to the rear of the shoulder block. The outer edge of both clavicles accommodates a design allowing for standard arm positions.
- 2.4.5 The shoulder cap (Part No 4d) is made of low-density polyurethane foam and is attached to the shoulder block.
- 2.5 **Thorax**
- 2.5.1 The thorax is shown as Part No 5 in Figure 1 of this Annex.
- 2.5.2 The thorax consists of a rigid thoracic spine box and three identical rib modules.
- 2.5.3 The thoracic spine box (Part No 5a) is made of steel. On the rear surface a lead-filled plastic back plate is mounted (Part No 5b).
- 2.5.4 The top surface of the thoracic spine box is inclined 5° backwards.
- 2.5.5 A rib module (Part No 5c) consists of a steel rib covered by a flesh-simulating polyurethane foam (Part No 5d), a piston-cylinder assembly (Part No 5e) linking the rib and spine box together, a hydraulic damper (Part No 5f) and a stiff damper spring (Part No 5g).
- 2.5.6 In the piston-cylinder assembly is a tuning spring (Part No 5h).
- 2.5.7 A displacement transducer (Part No 5i) can be mounted on the front face of the cylinder and connected to the inside of the rib.
- 2.6 **Arms**
- 2.6.1 The arms are shown as Part No 6 in Figure 1 of this Annex.

2.6.2. The arms have a plastic skeleton covered by a polyurethane 'flesh' and a PVC skin.

2.6.3 The shoulder/arm joint allows for discrete arm positions at 0°, 40° and 90° to the torso line.

2.6.4 The shoulder/arm joint allows for a flexion/extension rotation only.

2.7 Lumbar Spine

2.7.1 The lumbar spine is shown as Part No 7 in Figure 1 of this Annex.

2.7.2 The lumbar spine consists of a solid rubber cylinder with two steel interface plates at each end and a steel cable inside the cylinder

2.8 Abdomen

2.8.1 The abdomen is shown as Part No 8 in Figure 1 of this Annex.

2.8.2 The abdomen consists of a metal casting and a polyurethane foam covering.

2.8.3 The central part of the abdomen is a metal casting (Part No 8a). A cover plate is mounted on top of the casting.

2.8.4 The covering (Part No 8b) is made of polyurethane foam. A curved slab of rubber filled with lead pellets is integrated in the foam covering at both sides.

2.8.5 Between the foam covering and the rigid casting at each side of the abdomen, either three force transducers (Part No 8c) or three non-measuring 'dummy' units can be mounted.

2.9 Pelvis

2.9.1 The pelvis is shown as Part No 9 in Figure 1 of this Annex.

2.9.2 The pelvis consists of a sacrum block, two iliac wings, two hip joints and a foam covering.

2.9.3 The sacrum (Part No 9a) consists of a lead-filled aluminium block and an aluminium plate mounted on top of this block.

2.9.4 The iliac wings (Part No 9b) are made of polyurethane.

2.9.5 The hip joints (Part No 9c) are made of steel. They consist of an upper femur block and a ball joint connected to an axle passing through the dummy's H point.

2.9.6 The flesh system (Part No 9d) is made of a PVC skin filled with polyurethane foam. At the H point location the skin is replaced by a large open-cell polyurethane foam cylinder (Part No 9e), attached to a steel plate fixed on the iliac wing by an axle going through the ball joint.

2.9.7 The iliac wings are linked together at the pubic symphysis by a force transducer (Part No 9f) or a 'dummy' transducer.

2.10 **Legs**

2.10.1 The legs are shown as Part No 10 in Figure 1 of this Annex.

2.10.2 The legs consist of a metal skeleton covered by flesh-simulating polyurethane foam and a plastic skin.

2.10.3 The knee and ankle joints allow for a flexion extension rotation only.

2.11 **Suit**

2.11.1 The suit is shown as Part No 11 in Figure 1 of this Annex.

2.11.2 The suit is made of rubber and covers the shoulders, thorax, upper part of the arms, the abdomen and lumbar spine, and the upper part of the pelvis.

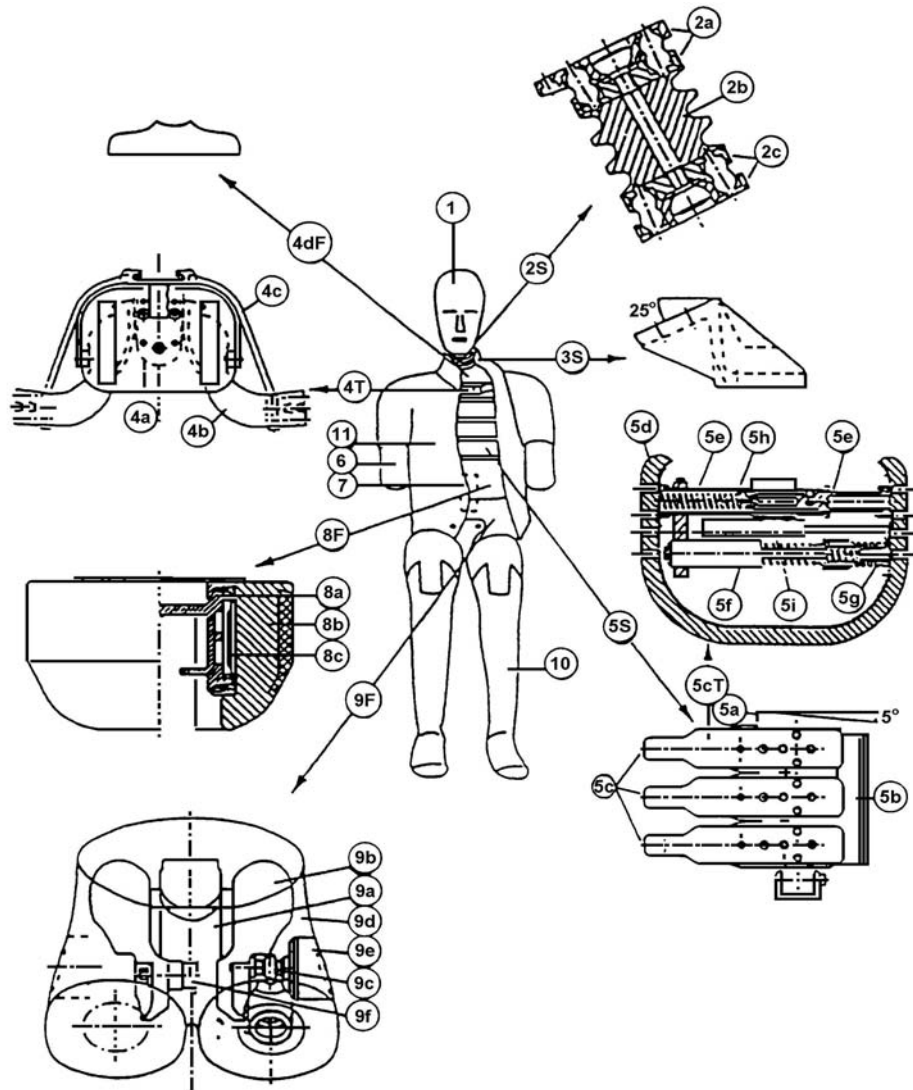

Figure 1

Construction of Side Impact Dummy

Table 1
Side Impact Dummy Components

Part No	Description	Number
1	Head	1
2	Neck	1
2a	Head/neck interface	1
2b	Central section	1
2c	Neck/thorax interface	1
3	Neck-bracket	1
4	Shoulder	1
4a	Shoulder block	1
4b	Clavicles	2
4c	Elastic cord	2
4d	Shoulder cap	1
5	Thorax	1
5a	Thoracic spine	1
5b	Back plate	1
5c	Rib module	3
5d	Rib covered with flesh	3
5e	Piston-cylinder assembly	3
5f	Damper	3
5g	Damper spring	3
5h	Tuning spring	3
5i	Displacement transducer	3
6	Arm	2
7	Lumbar spine	1
8	Abdomen	1

Part No	Description	Number
8a	Central casting	1
8b	Flesh covering	1
8c	Force transducer	3
9	Pelvis	1
9a	Sacrum block	1
9b	Iliac wing	2
9c	Hip joint	2
9d	Flesh covering	1
9e	H point foam block	2
9f	Force transducer	1
10	Leg	2
11	Suit	1

3 ASSEMBLY OF THE DUMMY

3.1. Head - Neck

- 3.1.1. The required torque on the hemi -spherical screws for assembly of the neck is 10 Nm.
- 3.1.2. The head is mounted to the head-neck interface plate of the neck by three screws.
- 3.1.3. The neck-thorax interface plate of the neck is mounted to the neck-bracket, by four screws.

3.2. Neck - Shoulder - Thorax

- 3.2.1. The neck-bracket is mounted to the shoulder block by four screws.
- 3.2.2. The shoulder block is mounted to the top-surface of the thoracic spine box by three screws.

- 3.3. **Shoulder - Arm**
 - 3.3.1. The arms may be mounted to the shoulder clavicles and adjusted by means of a screw and a bearing. The required torque to hold the arm in the defined standard position is 0.6 Nm.
- 3.4. Thorax - Lumbar Spine - Abdomen
 - 3.4.1. A lumbar spine adaptor is mounted by two screws to the lower part of the thoracic spine.
 - 3.4.2. The lumbar spine adaptor is mounted to the top of the lumbar spine by two screws.
 - 3.4.3. The top flange of the central abdominal casting is clamped between the lumbar spine adaptor and the lumbar spine.
- 3.5. **Lumbar Spine - Pelvis - Legs**
 - 3.5.1. The lumbar spine is mounted to the lumbar spine bottom plate by three screws.
 - 3.5.2. The lumbar spine bottom plate is mounted to the sacrum block of the pelvis by three screws.
 - 3.5.3. The legs are mounted to the upper femur-hip joint of the pelvis by a screw.
 - 3.5.4. The legs may be assembled and adjusted by means of hinge joints in the knees and ankles.
- 4. **MAIN CHARACTERISTICS**
 - 4.1. **Mass**
 - 4.1.1. The masses of the main dummy components are shown in Table 2 of this Annex.

Table 2
DUMMY COMPONENT MASSES

Component	Mass (kg)	Principal contents
Head	4.0 ± 0.4	Complete head including tri-axial accelerometer
Neck	1.0 ± 0.1	Neck, not including neck-bracket
Thorax	22.4 ± 1.5	Neck-bracket, shoulder, arm attachment bolts, spine box, spine back plate, rib modules, rib deflection transducers, lumbar spine adaptor, shoulder cap, abdomen central casting, abdomen force transducers, 2/3 of suit
Arm	1.3 ± 0.1	Upper arm, including arm positioning plate (each)
Abdomen	5.0 ± 0.5	Abdomen flesh covering lumbar spine
Pelvis	12.0 ± 1.0	Sacrum block, lumbar spine bottom plate, hip ball joint, upper femurs, iliac wings, pubic force transducer, pelvis flesh covering, 1/3 of suit
Leg	12.5 ± 1.0	Foot, lower and upper leg and flesh as far as junction with upper femur (each)
Total	72.0 ± 0.5	

4.2. Principal Dimensions

4.2.1. The principal dimensions of the side impact dummy (including the suit), based on Figure 2 of this Annex, are given in Table 3 of this Annex.

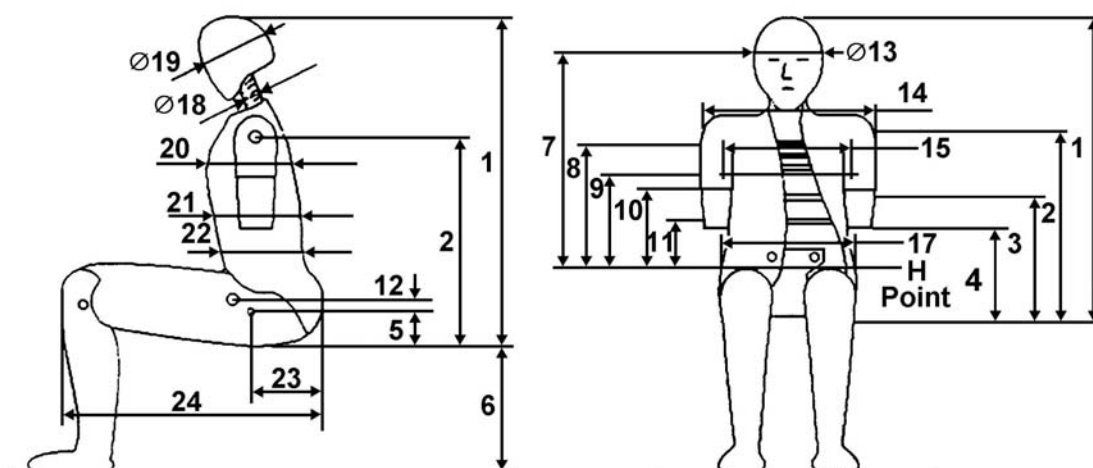

Figure 2

Measurements for Principle Dummy Dimensions

Table 3
PRINCIPLE DUMMY DIMENSIONS

No.	Parameter	Dimension (mm)
1	Sitting height	904 ± 7
2	Seat to shoulder joint	557 ± 5
3	Seat to bottom lower rib	357 ± 5
4	Seat to arm	242 ± 5
5	Seat to H-point	98 ± 2
6	Sole to seat, sitting	456 ± 5
7	H-point to head C of G	687 ± 5
8	H-point to centre upper rib	393 ± 3
9	H-point to centre middle rib	337 ± 3
10	H-point to centre lower rib	281 ± 3
11	H-point to centre abdominal force transducer	180 ± 3
12	H-point to centre pubic symphysis force transducer	14 ± 2
13	Head width	154 ± 2
14	Shoulder/arm width	482 ± 5
15	Thorax width	330 ± 5
16	Abdomen width	290 ± 5
17	Pelvis width	355 ± 5
18	Neck diameter	80 ± 2
19	Head depth	201 ± 5
20	Thorax depth	276 ± 5
21	Abdomen depth	204 ± 5
22	Pelvis depth	245 ± 5
23	Back of buttocks to H-point	157 ± 2
24	Back of buttocks to front knee	610 ± 5

5 CERTIFICATION OF THE DUMMY

5.1 Impact Side

- 5.1.1 Depending on the vehicle side to be impacted, dummy parts should be certified on the left hand side or right hand side.
- 5.1.2 The configurations of the rib modules (including instrumentation), the abdominal force transducers and the pubic symphysis transducer have to be converted to the required impact side.

5.2 Instrumentation

All instrumentation shall be calibrated in compliance with the requirements of the documentation specified in 1.3.

- 5.2.1 All instrumentation channels shall comply with ISO 6487:1987.

5.3 Visual Check

- 5.3.1 All dummy parts should be visually checked for damage and if necessary be replaced before the certification test.

5.4 General Test Set-up

- 5.4.1 Figure 3 of this Annex shows the test set-up for all certification tests on the side impact dummy.
- 5.4.2 The tests on the head, neck, thorax and lumbar spine are carried out on disassembled parts of the dummy.
- 5.4.3 The tests on the shoulder, abdomen and pelvis are performed with the complete dummy (without suit). In these tests the dummy is seated on a flat surface with two sheets of less than or equal to 2 mm thick Teflon placed between the dummy and the surface.
- 5.4.4 All parts to be certified shall be kept in the test room for a period of at least four hours at a temperature between 18°C and 22°C prior to a test.
- 5.4.5 The time between two repeated certification tests shall be at least 30 minutes.

5.5 Head

- 5.5.1 The head is dropped from 200 ± 1 mm onto a flat, rigid impact surface.
- 5.5.2 The angle between the impact surface and the midsagittal plane of the head is $35^\circ \pm 1^\circ$ allowing an impact of the upper-side of the head.
- 5.5.3 The peak resultant head acceleration, filtered using CFC 1 000, shall be between 100 g and 150 g.

- 5.5.4 The head performance may be adjusted to meet the requirement by altering the friction characteristics of the flesh-skull interface (e.g. by lubrication with talcum powder or PTFE spray).

5.6 Neck

- 5.6.1 The head-neck interface of the neck is mounted to a special symmetrical certification headform with a mass of 3.9 ± 0.05 kg (see figure 4).
- 5.6.2 The headform and neck are mounted upside-down to the bottom of a neck-bending pendulum allowing a lateral motion of the system.
- 5.6.3 The neck-pendulum is equipped with a uniaxial accelerometer mounted at $1\ 655 \pm 5$ mm from the pendulum pivot.
- 5.6.4 The neck-pendulum shall be allowed to fall freely from a height chosen to achieve an impact velocity of 3.4 ± 0.1 m/s measured at the accelerometer location.
- 5.6.5 The neck-pendulum is decelerated from impact velocity to zero by an appropriate device, resulting in a deceleration-time history inside the corridor specified in Figure 5 of this Annex. All channels have to be recorded using ISO CFC 1000 filters and filtered digitally using CFC 60.
- 5.6.6 The maximum headform flexion angle relative to the pendulum shall be $51 \pm 5^\circ$ and occur after between 50 and 62 ms.
- 5.6.7 The maximum headform centre of gravity displacements in the lateral and vertical directions shall be 97 ± 10 mm and 26 ± 6 mm respectively.
- 5.6.8 The neck performance can be adjusted by replacing the circular section buffers with buffers of a different Shore hardness.

5.7 Shoulder

- 5.7.1 The length of the elastic cord shall be adjusted so that a force between 27.5 N and 32.5 N applied in a forward direction 4 ± 1 mm from the outer edge of the clavicle in the same plane as the clavicle movement is required to move the clavicle forward.
- 5.7.2 The dummy is seated on a flat, horizontal, rigid surface with no back support. The thorax is positioned vertically and the arms should be set at an angle of $40^\circ \pm 2^\circ$ forward to the vertical. The legs are positioned horizontally.
- 5.7.3 The impactor is a pendulum of 23.5 ± 0.2 kg and 152 ± 2 mm diameter. The impactor is suspended from a rigid support by four wires with the centre line of the impactor at least 3.5 m below the rigid support.

- 5.7.4 The impactor is equipped with an accelerometer sensitive in the direction of impact and located on the impactor axis.
- 5.7.5 The impactor shall freely swing onto the shoulder of the dummy with an impact velocity of 4.3 ± 0.1 m/s.
- 5.7.6 The impact direction is perpendicular to the anterior-posterior axis of the dummy and the axis of the impactor coincides with the axis of the upper arm pivot.
- 5.7.7 The peak acceleration of the impactor, filtered using CFC 180, shall be between 7.5 and 10.5 g.

5.8 Arms

- 5.8.1 No dynamic certification procedure is defined for the arms.

5.9 Thorax

- 5.9.1 Each rib module is certified separately.
- 5.9.2 The rib module is positioned vertically in a drop test rig and the rib cylinder is clamped rigidly onto the rig.
- 5.9.3 The impactor is a free fall mass of $7.8 + 0 - 0.1$ kg with a flat face and a diameter of 150 ± 2 mm.
- 5.9.4 The centre line of the impactor shall be aligned with the centre line of the rib's piston.
- 5.9.5 The impact velocity is 1.0, 2.0, 3.0 and 4.0 m/s respectively. Impact velocities may not vary from those specified by more than 2%.
- 5.9.6 The rib displacement should be measured, for instance using the rib's own displacement transducer.
- 5.9.7 The rib certification requirements are shown in Table 4 of this Annex.
- 5.9.8 The performance of the rib module may be adjusted by replacing the tuning spring inside the cylinder with one of a different stiffness.

Table 4

Certification Requirements for the Full Rib Module

Impact Velocity (m/s)	Displacement	
	Minimum	Maximum
1.0	10.0	14.0
2.0	23.5	27.5
3.0	36.0	40.0
4.0	46.0	51.0

5.10 Lumbar Spine

- 5.10.1 The lumbar spine is mounted to the special symmetrical certification headform with a mass of 3.9 ± 0.05 kg (see Figure 4).
- 5.10.2 The headform and lumbar spine are mounted upside-down to the bottom of a neck-bending pendulum allowing a lateral motion of the system.
- 5.10.3 The neck-pendulum is equipped with a uniaxial accelerometer mounted at $1\ 655 \pm 5$ mm from the pendulum pivot.
- 5.10.4 The neck-pendulum is allowed to fall freely from a height chosen to achieve an impact velocity of 6.05 ± 0.1 m/s measured at the accelerometer location.
- 5.10.5 The neck-pendulum is decelerated from impact velocity to zero by an appropriate device, resulting in a deceleration-time history inside the corridor specified in Figure 6 of this Annex. All channels shall be recorded using ISO 6487 CFC 1000 filters and filtered digitally using CFC 60.
- 5.10.6 The maximum headform flexion angle relative to the pendulum shall be $50 \pm 5^\circ$ and occur after between 39 and 53 ms.
- 5.10.7 The maximum headform centre of gravity displacements in the lateral and vertical direction shall be 104 ± 7 mm and 33 ± 7 mm respectively.
- 5.10.8 The performance of the lumbar spine may be adjusted by changing the length of the spine.

5.11 Abdomen

- 5.11.1 The dummy is seated on a flat, horizontal, rigid surface with no back support. The thorax is positioned vertically, while the arms and legs are positioned horizontally.
- 5.11.2 The impactor is a pendulum of $23.5 + 0$ to 0.2 kg and 152 ± 2 mm diameter.
- 5.11.3 The pendulums equipped with a horizontal 'armrest' impactor face of 1.0 ± 0.01 kg. The total mass of the impactor with the armrest face is $24.5 + 0$ to 0.2 kg. The rigid armrest is 70 ± 1 mm high, 150 ± 1 mm wide and should be allowed to penetrate at least 60 mm into the abdomen. The centre line of the pendulum coincides with the centre of the armrest.
- 5.11.4 The impactor is equipped with an accelerometer sensitive in the direction of impact and located on the impactor axis.

- 5.11.5 The impactor shall freely swing onto the abdomen of the dummy with an impact velocity of 6.3 ± 0.1 m/s.
- 5.11.6 The impact direction is perpendicular to the anterior-posterior axis of the dummy and the axis of the impactor is aligned with the centre of the middle force transducer.
- 5.11.7 The peak force of the impactor, obtained from the impactor acceleration filtered using CFC 180 and multiplied by the impactor/armrest mass, shall be between 9.5 and 11.1 kN, and occur after between 9.8 and 11.4 ms.
- 5.11.8 The force-time histories measured by the three abdominal force transducers shall be summed and filtered using CFC 600. The peak force of this sum shall be between 5.9 and 7.9 kN.

5.12 Pelvis

- 5.12.1 The dummy is seated on a flat, horizontal, rigid surface with no back support. The thorax is positioned vertically while the arms and legs are positioned horizontally.
- 5.12.2 The impactor is a pendulum of $23.5 + 0.2$ kg and 152 ± 2 mm diameter.
- 5.12.3 The impactor is equipped with an accelerometer sensitive in the direction of impact and located on the impactor axis.
- 5.12.4 The impactor should freely swing onto the pelvis of the dummy with an impact velocity of $4.3 \pm 0,1$ m/s.
- 5.12.5 The impact direction is perpendicular to the anterior-posterior axis of the dummy and the axis of the impactor is aligned with the centre of the H point foam cylinder.
- 5.12.6 The peak force of the impactor, obtained from the impactor acceleration filtered using CFC 180 and multiplied by the impactor mass, should be between 4.4 and 5.4 kN, and occur after between 10.3 and 15.5 ms.
- 5.12.7 The pubic symphysis force, filtered using CFC 600, should be between 1.04 and 1.64 kN and occur after between 9.9 and 15.9 ms.

5.13 Legs

5.13.1 No dynamic certification procedure is defined for the legs.

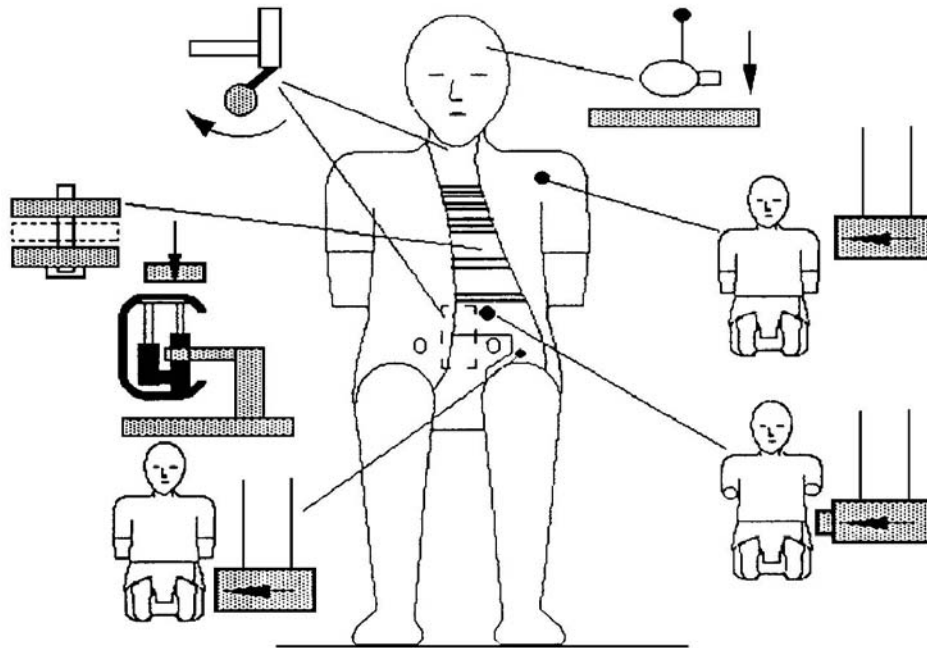

Figure 3

Overview of the Side Impact Dummy Certification Test Set-up

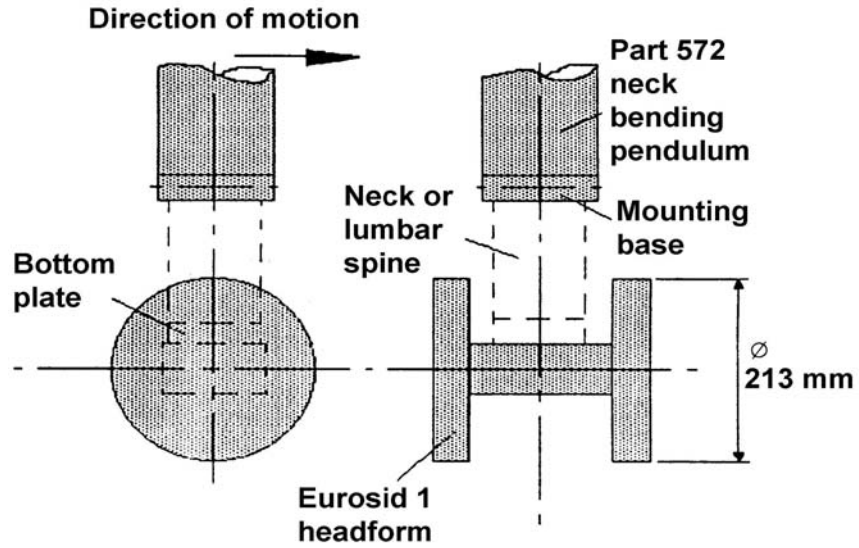

Figure 4

Neck and Lumbar Spine Certification Test Set-up

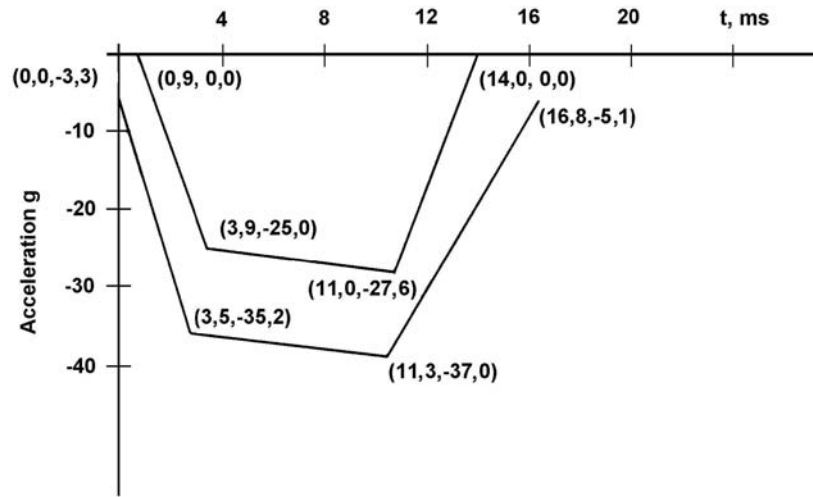

Figure 5

Pendulum Deceleration-time Corridor for Neck Certification Test

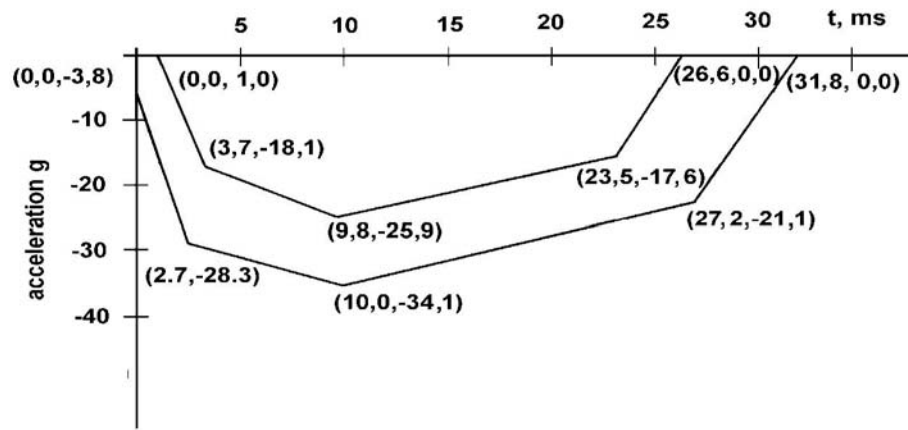

Figure 6

Pendulum Deceleration-time Corridor for Lumbar Spine Certification Test

ANNEX 3 (B)

(See Annex 1-2.2)

TECHNICAL DESCRIPTION OF THE SIDE IMPACT DUMMY**1. GENERAL**

- 1.1. The side impact dummy prescribed in this standard, including the instrumentation and calibration, is described in technical drawings and user's manual ⁽¹⁾.
- 1.2. The dimensions and masses of the side impact dummy represent a 50th percentile adult male, without lower arms.
- 1.3. The side impact dummy consists of a metal and plastic skeleton covered by flesh-simulating rubber, plastic and foam.

2. CONSTRUCTION

- 2.1. For an overview of the side impact dummy see Figure 1 for a scheme and the parts breakdown in Table 1 of this Annex.

2.2. Head

- 2.2.1. The head is shown as Part No. 1 in Figure 1 of this Annex.
- 2.2.2. The head consists of an aluminium shell covered by a pliable vinyl skin. The interior of the shell is a cavity accommodating triaxial accelerometers and ballast.
- 2.2.3. At the head-neck interface a load cell replacement is built in. This part can be replaced with an upper neck load-cell.

2.3. Neck

- 2.3.1. The neck is shown as Part No. 2 in Figure 1 of this Annex.
- 2.3.2. The neck consists of a head-neck. interface piece, a neck-thorax interface piece and a central section that links the two interfaces to one another.
- 2.3.3. The head-neck interface piece (Part No. 2a) and the neck-thorax interface piece (Part No. 2c) both consist of two aluminium disks linked together by means of a half spherical screw and eight rubber buffers.

(1) The dummy is corresponding with the specification of the ES-2 dummy. The number of the table of contents of the technical drawing is: No. E-AA-DRAWING-LIST-7-25-032 dated on July 25, 2003. The complete set of ES-2 technical drawings and the ES-2 User Manual are deposited with the United Nations Economic Commission for Europe (UNECE), Palais des Nations, Geneva, Switzerland and may be consulted on request at the secretariat.

- 2.3.4. The cylindrical central section (Part No. 2b) is made of rubber. At both sides an aluminium disk of the interface pieces is moulded in the rubber part.
- 2.3.5. The neck is mounted on the neck-bracket, shown as Part No. 2d in Figure 1 of this Annex. This bracket can optionally be replaced with a lower neck load-cell.
- 2.3.6. The angle between the two faces of the neck-bracket is 25°. Because the shoulder block is inclined 5° backwards, the resulting angle between the neck and torso is 20°.
- 2.4. **Shoulder**
- 2.4.1. The shoulder is shown as Part No. 3 in Figure 1 of this Annex.
- 2.4.2. The shoulder consists of a shoulder box, two clavicles and a shoulder foam cap.
- 2.4.3. The shoulder box (Part No. 3a) consists of an aluminium spacer block, an aluminium plate on top and an aluminium plate on the bottom of the spacer block. Both plates are covered with a polytetrafluorethen (PTFE)-coating.
- 2.4.4. The clavicles (Part No. 3b), made of cast polyurethane (PU)-resin, are designed to evolve over the spacer block. The clavicles are held back in their neutral position by two elastic cords (Part No. 3c) which are clamped to the rear of the shoulder box. The outer edge of both clavicles accommodates a design allowing for standard arm positions.
- 2.4.5. The shoulder cap (Part No. 3d) is made of low-density polyurethane foam and is attached to the shoulder block.
- 2.5. **Thorax**
- 2.5.1. The thorax is shown as Part No. 4 in Figure 1 of this Annex.
- 2.5.2. The thorax consists of a rigid thoracic spine box and three identical rib modules.
- 2.5.3. The thoracic spine box (Part No. 4a) is made of steel. On the rear surface a steel spacer and curved, polyurethane (PU)-resin, back plate is mounted (Part No. 4b).
- 2.5.4. The top surface of the thoracic spine box is inclined 5° backwards.
- 2.5.5. At the lower side of the spine box T12 load cell or load cell replacement (Part No. 4j) is mounted.

- 2.5.6. A rib module (Part No. 4c) consists of a steel rib bow covered by a flesh-simulating open-cell polyurethane (PU) foam (Part No. 4d), a linear guide system assembly (Part No. 4e) linking the rib and spine box together, a hydraulic damper (Part No. 4f) and a stiff damper spring (Part No. 4g).
- 2.5.7. The linear guide system (Part No. 4e) allows the sensitive rib side of the rib bow (Part No. 4d) to deflect with respect to the spine box (Part No. 4a) and the non-sensitive side. The guide system assembly is equipped with linear needle bearings.
- 2.5.8. A tuning spring is located in the guide system assembly (Part No. 4h).
- 2.5.9. A rib displacement transducer (Part No. 4i) can be installed on the spine box mounted part of guide system (Part No. 4e) and connected to the outer end of the guide system at the sensitive side of the rib.
- 2.6. **Arms**
- 2.6.1. The arms are shown as Part No. 5 in Figure 1 of this Annex.
- 2.6.2. The arms have a plastic skeleton covered by a polyurethane (PU) flesh representation with a polyvinylchloride (PVC) skin. The flesh representation consists of a high-density polyurethane (PU) moulding upper part and a polyurethane (PU) foam lower part.
- 2.6.3. The shoulder-arm joint allows for discrete arm positions at 0°, 40° and 90° setting with respect to the torso axis.
- 2.6.4. The shoulder-arm joint allows for a flexion-extension rotation only.
- 2.7. **Lumbar Spine**
- 2.7.1. The lumbar spine is shown as Part No. 6 in Figure 1 of this Annex.
- 2.7.2. The lumbar spine consists of a solid rubber cylinder with two steel interface plates at each end, and a steel cable inside the cylinder.
- 2.8. **Abdomen**
- 2.8.1. The abdomen is shown as Part No. 7 in Figure 1 of this Annex.
- 2.8.2. The abdomen consists of a rigid central part and a foam covering.
- 2.8.3. The central part of the abdomen is a metal casting (Part No. 7a). A cover plate is mounted on top of the casting.
- 2.8.4. The covering (Part No. 7b) is made of polyurethane (PU) foam. A curved slab of rubber filled with lead-pellets is integrated in the foam covering at both sides.

2.8.5. Between the foam covering and the rigid casting at each side of the abdomen, either three force transducers (Part No. 7c) or three non-measuring replacement units can be mounted.

2.9. Pelvis

2.9.1. The pelvis is shown as Part No. 8 in Figure 1 of this Annex.

2.9.2. The pelvis consists of a sacrum block, two iliac wings, two hip joints assemblies and a flesh simulating foam covering.

2.9.3. The sacrum (Part No. 8a) consists of a mass tuned metal block and a metal plate mounted on top of this block. In the aft side of the block is a cavity to facilitate the application of instrumentation.

2.9.4. The iliac wings (Part No. 8b) are made of polyurethane (PU)-resin.

2.9.5. The hip joints assemblies (Part No. 8c) are made of steel parts. They consist of an upper femur bracket and a ball joint connected to an axle passing through the dummy's H-Point. The upper femur bracket abduction and adduction capability is buffered by rubber stops at the ends of the range of motion.

2.9.6. The flesh system (Part No. 8d) is made of a polyvinylchloride (PVC) skin filled with polyurethane (PU) foam. At the H-Point location the skin is replaced by open-cell polyurethane (PU) foam block (Part No. 8e) backed up with a steel plate fixed on the iliac wing by an axle going through the ball joint.

2.9.7. The iliac wings are attached to the sacrum block at the aft side and linked together at the pubic symphysis location by a force transducer (Part No. 8f) or a replacement transducer.

2.10. Legs

2.10.1. The legs are shown as Part No. 9 in Figure 1 of this Annex.

2.10.2. The legs consist of a metal skeleton covered by a flesh-simulating polyurethane (PU) foam with a polyvinylchloride (PVC) skin.

2.10.3. A high-density polyurethane (PU) moulding with a polyvinylchloride (PVC) skin represents the thigh flesh of the upper legs.

2.10.4. The knee and ankle joint allow for a flexion/extension rotation only.

2.11. Suit

2.11.1. The suit is not shown in Figure 1 of this Annex.

2.11.2. The suit is made of rubber and covers the shoulders, thorax, upper part of the arms, the abdomen and lumbar spine, the upper part of the pelvis.

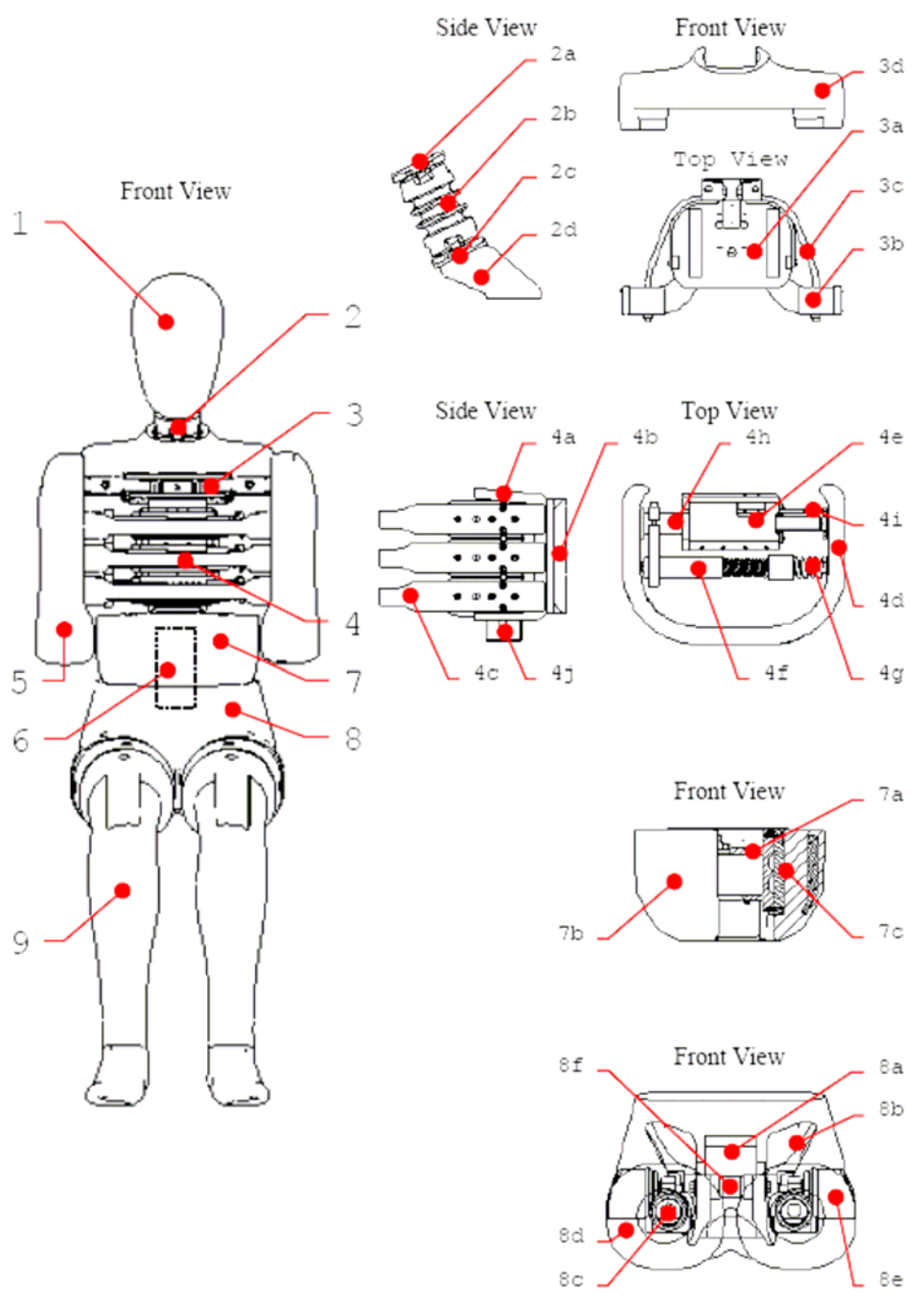

Figure 1
Construction of Side Impact Dummy

Table 1
Side Impact Dummy Components (See Figure 1)

Part	No.	Description	Number per dummy
1		Head	1
2		Neck	1
	2a	Head-neck interface	1
	2b	Central section	1
	2c	Neck-thorax interface	1
	2d	Neck-bracket	1
3		Shoulder	1
	3a	Shoulder box	1
	3b	Clavicle	2
	3c	Elastic cord	2
	3d	Shoulder foam cap	1
4		Thorax	1
	4a	Thoracic spine	1
	4b	Back plate (curved)	1
	4c	Rib module	3
	4d	Rib bow covered with flesh	3
	4e	Piston-cylinder assembly	3
	4f	Damper	3
	4g	Stiff damper spring	3
	4h	Tuning spring	3
	4I	Displacement transducer	3
	4j	T12 load cell or load cell replacement	1
5		Arm	2
6		Lumbar spine	1
7		Abdomen	1
	7a	Central casting	1
	7b	Foam covering	1
	7c	Force transducer or replacement	3
8		Pelvis	1
	8a	Sacrum block	1
	8b	Iliac wings	2
	8c	Hip joint assembly	2
	8d	Flesh covering	1
	8e	H-Point foam block	1
	8f	Force transducer or replacement	1
9		Leg	2
10		Suit	1

3. ASSEMBLY OF THE DUMMY

3.1. Head-neck

- 3.1.1. The required torque on the half spherical screws for assembly of the neck is 10 Nm.
- 3.1.2. The head-upper neck load cell assembly is mounted to the head-neck interface plate of the neck by four screws.
- 3.1.3. The neck-thorax interface plate of the neck is mounted to the neck-bracket by four screws.

3.2. Neck-shoulder-thorax

- 3.2.1. The neck-bracket is mounted to the shoulder block by four screws.
- 3.2.2. The shoulder-block is mounted to the top-surface of the thoracic spine box by three screws.

3.3. Shoulder-arm

- 3.3.1. The arms are mounted to the shoulder clavicles by means of a screw and an axial bearing. The screw shall be tightened to obtain a 1 - 2 g holding force of the arm on its pivot.

3.4. Thorax-lumbar spine-abdomen

- 3.4.1. The mounting direction of rib modules in the thorax shall be adapted to the required impact side.
- 3.4.2. A lumbar spine adaptor is mounted to the T12 load cell or load cell replacement at the lower part of the thoracic spine by two screws.
- 3.4.3. The lumbar spine adaptor is mounted to the top plate of the lumbar spine with four screws.
- 3.4.4. The mounting flange of the central abdominal casting is clamped between the lumbar spine adaptor and the lumbar spine top plate.
- 3.4.5. The location of the abdominal force transducers shall be adapted to the required impact side.

3.5. Lumbar spine-pelvis-legs

- 3.5.1. The lumbar spine is mounted to the sacrum block cover plate by three screws. In case of using the lower lumbar spine load cell four screws are used.
- 3.5.2. The lumbar spine bottom plate is mounted to the sacrum block of the pelvis by three screws.

- 3.5.3. The legs are mounted to the upper femur bracket of the pelvis hip joint assembly by a screw.
- 3.5.4. The knee and ankle links in the legs can be adjusted to obtain a 1 - 2 g holding force.

4 MAIN CHARACTERISTICS

4.1 Mass

- 4.1.1 The masses of the main dummy components are presented in Table 2 of this Annex.

Table 2
Dummy component Masses

Component (body part)	Mass (kg)	Tolerance ± (kg)	Principal Contents
Head	4.0	0.2	Complete head assembly including tri-axial accelerometer and upper neck load cell or replacement
Neck	1.0	0.05	Neck, not including neck-bracket
Thorax	22.4	1.0	Neck bracket, shoulder cap, shoulders assembly, arm attachment bolts, spine box, torso back plate, rib modules, rib deflection transducers, torso back plate load cell or replacement, T12-load cell or replacement, abdomen central casting, abdominal force transducers, 2/3 of suit.
Arm (each)	1.3	0.1	Upper arm, including arm positioning plate (each)
Abdomen and lumbar spine	5.0	0.25	Abdomen flesh covering and lumbar spine
Pelvis	12.0	0.6	Sacrum block, lumbar spine mounting plate, hip ball joints, upper femur brackets, iliac wings, pubic force transducer, pelvis flesh covering, 1/3 of suit.
Leg (each)	12.7	0.6	Foot, lower and upper leg and flesh as far as junction with upper femur (each).
Total dummy	72.0	1.2	

4.2 Principal Dimensions

4.2.1 The principle dimensions of the side impact dummy, based on Figure 2 of this Annex, are given in Table 3 of this Annex.

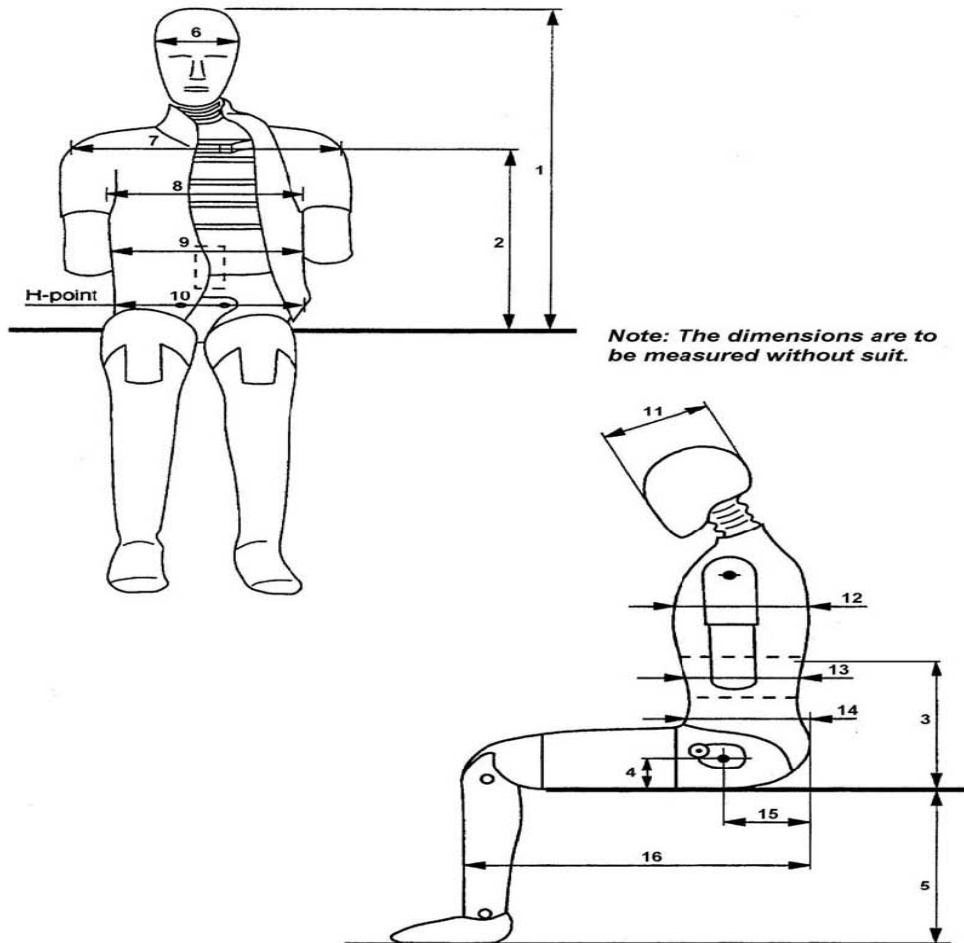

Figure 2

Measurements for Principle Dummy Dimensions (see Table 3)

Table 3
Principle Dummy Dimensions

No.	Parameter	Dimension (mm)
1.	Sitting height	909 ± 9
2.	Seat to shoulder joint	565 ± 7
3.	Seat to lower face of thoracic spine box	351 ± 5
4.	Seat to hip joint (centre of bolt)	100 ± 3
5.	Sole to seat, sitting	442 ± 9
6.	Head width	155 ± 3
7.	Shoulder/arm width	470 ± 9
8.	Thorax width	327 ± 5
9.	Abdomen width	280 ± 7
10.	Pelvis lap width	366 ± 7
11.	Head depth	201 ± 5
12.	Thorax depth	267 ± 5
13.	Abdomen depth	199 ± 5
14.	Pelvis depth	240 ± 5
15.	Back of buttocks to hip joint (centre of bolt)	155 ± 5
16.	Back of buttocks to front knee	606 ± 9

5 CERTIFICATION OF THE DUMMY

5.1 Impact Side

5.1.1 Depending on the vehicle side to be impacted, dummy parts should be certified on the left hand side or right hand side.

5.1.2 The configurations of the dummy with regards to the mounting direction of the rib modules and the location of the abdominal force transducers shall be adapted to the required impact side.

5.2 Instrumentation

5.2.1 All instrumentation shall be calibrated in compliance with the requirements of the documentation specified in paragraph 1.3.

- 5.2.2 All instrumentation channels shall comply with ISO 6487:2000 or SAE J211 (March 1995) data channel recording specification.
- 5.2.3 The minimum number of channels required to comply with this standard is ten:
- | | |
|--------------------------|---------|
| Head accelerations | (3), |
| Thorax rib displacements | (3), |
| Abdomen loads | (3) and |
| Pubic symphysis load | (1). |
- 5.2.4 Additionally a number of optional instrumentation channels (38) are available:
- | | |
|------------------------|-----------------------|
| Upper neck loads | (6), |
| Lower neck loads | (6), |
| Clavicle loads | (3), |
| Torso back plate loads | (4), |
| T1 accelerations | (3), |
| T12 accelerations | (3), |
| Rib accelerations | (6, two on each rib), |
| T12 spine loads | (4), |
| Lower lumbar loads | (3), |
| Pelvis accelerations | (3) and |
| Femur loads | (6). |
- Additional four position indicator channels are optionally available:
- | | |
|------------------|---------|
| Thorax rotations | (2) and |
| Pelvis rotations | (2) |

5.3 Visual Check

- 5.3.1 All dummy parts should be visually checked for damage and if necessary be replaced before the certification test.

5.4 General Test Set-up

- 5.4.1 Figure 3 of this Annex shows the test set-up for all certification tests on the side impact dummy.
- 5.4.2 The certification test set-up arrangements and testing procedures shall be in accordance with the specification and requirements of the documentation specified in paragraph 1.3.
- 5.4.3 The tests on the head, neck, thorax and lumbar spine are carried out on sub-assemblies parts of the dummy.
- 5.4.4 The tests on the shoulder, abdomen and pelvis are performed with the complete dummy (without suit, shoes and underwear). In these tests the dummy is seated on a flat surface with two sheets of less than or equal to 2 mm thick polytetrafluorethen (PTFE), placed between the dummy and the flat surface.

- 5.4.5 All parts to be certified should be kept in the test room for a period of at least four hours at a temperature between and including 18°C and 22°C and a relative humidity between and including 10% and 70% prior to a test.
- 5.4.6 The time between two certification tests on the same part should be at least 30 minutes.
- 5.5 **Head**
- 5.5.1 The head sub-assembly, including the upper neck load cell replacement, is certified in a drop test from 200 ± 1 mm onto a flat, rigid impact surface.
- 5.5.2 The angle between the impact surface and the mid-sagittal plane of the head is $35^\circ \pm 1^\circ$ allowing an impact to the upper part of the head side (this can be realised with a sling harness or a head drop support bracket with a mass of 0.075 ± 0.005 kg).
- 5.5.3 The peak resultant head acceleration, filtered using ISO 6487:2000 CFC 1000, should be between 100 g and 150 g.
- 5.5.4 The head performance can be adjusted to meet the requirement by altering the friction characteristics of the skin-skull interface (e.g. by lubrication with talcum powder or polytetrafluorethen (PTFE) spray).
- 5.6 **Neck**
- 5.6.1 The head-neck interface of the neck is mounted to a special certification headform with a mass of 3.9 ± 0.05 kg (see Figure 6), with the help of a 12 mm thick interface plate with a mass of 0.205 ± 0.05 kg.
- 5.6.2 The head-form and neck are mounted upside-down to the bottom of a neck-pendulum ⁽¹⁾ allowing a lateral motion of the system.
- 5.6.3 The neck-pendulum is equipped with a uni-axial accelerometer according to the neck pendulum specification (see Figure 5).
- 5.6.4 The neck-pendulum should be allowed to fall freely from a height chosen to achieve an impact velocity of 3.4 ± 0.1 m/s measured at the pendulum accelerometer location.
- 5.6.5 The neck-pendulum is decelerated from impact velocity to zero by an appropriate device ⁽²⁾, as described in the neck pendulum specification (see Figure 5), resulting in a velocity change -time history inside the corridor specified in Figure 7 and Table 4 of this Annex. All channels have to be recorded according to the ISO 6487:2000 or SAE J211 (March 1995) data channel recording specification and filtered digitally using ISO 6487:2000 CFC 180.

⁽¹⁾ Neck pendulum corresponding with American Code of Federal Regulation 49 CFR Chapter V Part 572.33 (10-1-00 Edition) (See also Figure 5).

⁽²⁾ The use of 3 -inch honeycomb is recommended

Table 4

Pendulum Velocity Change – Time Corridor for Neck Certification Test

Upper Boundary Time (s)	Velocity (m/s)	Lower Boundary Time (s)	Velocity (m/s)
0.001	0.0	0	-0.05
0.003	-0.25	0.0025	-0.375
0.014	-3.2	0.0135	-3.7
		0.017	-3.7

5.6.6 The maximum headform flexion angle relative to the pendulum (Angle $d\theta A + d\theta C$ in Figure 6) should be between and including 49.0° and 59.0° and should occur between and including 54.0 and 66.0 ms.

5.6.7 The maximum headform centre of gravity displacements measured in angle $d\theta A$ and $d\theta B$ (see Figure 6) should be: Fore pendulum base angle $d\theta A$ between and including 32.0° and 37.0° occurring between and including 53.0 and 63.0 ms and aft pendulum base angle $d\theta B$ between and including $0.81^* (\text{angle } d\theta A) + 1.75$ and $0.81^* (\text{angle } d\theta A) + 4.25^\circ$ occurring between and including 54.0 and 64.0 ms

5.6.8 The neck performance can be adjusted by replacing the eight circular section buffers with buffers of another shore hardness

5.7 Shoulder

5.7.1 The length of the elastic cord should be adjusted so that a force between and including 27.5 N and 32.5 N applied in a forward direction 4 ± 1 mm from the outer edge of the clavicle in the same plane as the clavicle movement, is required to move the clavicle forward.

5.7.2 The dummy is seated on a flat, horizontal, rigid surface with no back support. The thorax is positioned vertically and the arms should be set at an angle of $40^\circ \pm 2^\circ$ forward to the vertical. The legs are positioned horizontally.

5.7.3 The impactor is a pendulum with a mass of 23.4 ± 0.2 kg and diameter of 152.4 ± 0.25 mm with an edge radius of 12.7 mm⁽¹⁾ The impactor is suspended from rigid hinges by four wires with the centre line of the impactor at least 3.5 m below the rigid hinges (see Figure 4).

- 5.7.4 The impactor is equipped with an accelerometer sensitive in the direction of impact and located on the impactor axis.
- 5.7.5 The impactor should freely swing onto the shoulder of the dummy with an impact velocity of 4.3 ± 0.1 m/s.
- 5.7.6 The impact direction is perpendicular to the anterior-posterior axis of the dummy and the axis of the impactor coincides with the axis of the upper arm pivot.
- 5.7.7 The peak acceleration of the impactor, filtered using ISO 6487:2000 CFC 180, should be between and including 7.5 and 10.5 g.
- 5.8 **Arms**
- 5.8.1 No dynamic certification procedure is defined for the arms.
- 5.9 **Thorax**
- 5.9.1 Each rib module is certified separately.
- 5.9.2 The rib module is positioned vertically in a drop test rig and the rib cylinder is clamped rigidly onto the rig.
- 5.9.3 The impactor is a free fall mass of 7.78 ± 0.1 kg with a flat face and a diameter of 150 ± 2 mm.
- 5.9.4 The centre line of the impactor should be aligned with the centre line of the rib's guide system.
- 5.9.5 The impact severity is specified by the drop heights of 815, 204 and 459 mm. These drop heights result in velocities of approximately 4, 2 and 3 m/s respectively. Impact drop heights should be applied with an accuracy of 1%.
- 5.9.6 The rib displacement should be measured, for instance using the rib's own displacement transducer.
- 5.9.7 The rib certification requirements are given in Table 5 of this Annex.
- 5.9.8 The performance of the rib module can be adjusted by replacing the tuning spring inside the cylinder with one of a different stiffness.

⁽¹⁾ Pendulum corresponding with American Code of Federal Regulation 49 CFR Chapter V Part 572.36(a) (10-1-00 Edition (See also Figure 4).

Table 5

Requirements for Full Rib Module Certification

Test sequence	Drop height (accuracy 1%) (mm)	Minimum Displacement (mm)	Maximum Displacement (mm)
1	815	46.0	51.0
2	204	23.5	27.5
3	459	36.0	40.0

5.10 Lumbar spine

- 5.10.1 The lumbar spine is mounted to the special certification headform with a mass of 3.9 ± 0.05 kg (see Figure 6), with the help of a 12 mm thick interface plate with a mass of 0.205 ± 0.05 kg.
- 5.10.2 The headform and lumbar spine are mounted upside-down to the bottom of a neck-pendulum ⁽¹⁾ allowing a lateral motion of the system.
- 5.10.3 The neck-pendulum is equipped with an uniaxial accelerometer according to the neck-pendulum specification (see Figure 5).
- 5.10.4 The neck-pendulum should be allowed to fall freely from a height chosen to achieve an impact velocity of 6.05 ± 0.1 m/s measured at the pendulum accelerometer location.
- 5.10.5 The neck-pendulum is decelerated from impact velocity to zero by an appropriate device, ⁽²⁾ as described in the neck-pendulum specification (see Figure 5), resulting in a velocity change -time history inside the corridor specified in Figure 8 and Table 6 of this Annex. All channels have to be recorded according to the ISO 6487:2000 or SAE J211 (March 1995) data channel recording specification and filtered digitally, using ISO 6487:2000 CFC 180.

Table 6

Pendulum Velocity Change –
Time Corridor for Lumbar Spine Certification Test

Upper Boundary Time (s)	Velocity (m/s)	Lower Boundary Time (s)	Velocity (m/s)
0.001	0.0	0	-0.05
0.0037	-0.2397	0.0027	-0.425
0.027	-5.8	0.0245	-6.5
		0.03	-6.5

⁽¹⁾ Neck pendulum corresponding with American Code of Federal Regulation 49 CFR Chapter V Part 572.33 (10-1-00 Edition) (See also Figure 5).

⁽²⁾ The use of 6-inch honeycomb is recommended (see Figure 5).

- 5.10.6 The maximum headform flexion angle relative to the pendulum (Angle $d\theta A + d\theta C$ in Figure 6) should be between and including 45.0° and 55.0° and should occur between and including 39.0 and 53.0 ms.
- 5.10.7 The maximum headform centre of gravity displacements measured in angle $d\theta A$ and $d\theta B$ (see Figure 6) should be: Fore pendulum base angle $d\theta A$ between and including 31.0° and 35.0° occurring between and including 44.0 and 52.0 ms and aft pendulum base angle $d\theta B$ between and including $0.8 * (\text{angle } d\theta A) + 2.00$ and $0.8 * (\text{angle } d\theta A) + 4.50^\circ$ occurring between and including 44.0 and 52.0 ms.
- 5.10.8 The performance of the lumbar spine can be adjusted by changing tension in the spine cable.
- 5.11 **Abdomen**
- 5.11.1 The dummy is seated on a flat, horizontal, rigid surface with no back support. The thorax is positioned vertically, while the arms and legs are positioned horizontally.
- 5.11.2 The impactor is a pendulum with a mass of 23.4 ± 0.2 kg and diameter of 152.4 ± 0.25 mm with an edge radius of 12.7 mm ⁽¹⁾. The impactor is suspended from rigid hinges by eight wires with the centre line of the impactor at least 3.5 m below the rigid hinges (see Figure 4).
- 5.11.3 The impactor is equipped with an accelerometer sensitive in the direction of impact and located on the impactor axis.
- 5.11.4 The pendulum equipped with a horizontal "arm rest" impactor face of 1.0 ± 0.01 kg. The total mass of the impactor with the arm rest face is 24.4 ± 0.21 kg. The rigid "arm rest" is 70 ± 1 mm high, 150 ± 1 mm wide and should be allowed to penetrate at least 60 mm into the abdomen. The centreline of the pendulum coincides with the centre of the "arm rest".
- 5.11.5 The impactor should freely swing onto the abdomen of the dummy with an impact velocity of 4.0 ± 0.1 m/s.
- 5.11.6 The impact direction is perpendicular to the anterior-posterior axis of the dummy and the axis of the impactor is aligned with the centre of the middle abdominal force transducer.
- 5.11.7 The peak force of the impactor, obtained from the impactor acceleration filtered using ISO 6487:2000 CFC 180 and multiplied by the impactor/armrest mass, should be between and including 4.0 and 4.8 kN, and occur between and including 10.6 and 13.0 ms.
- 5.11.8 The force-time histories measured by the three abdominal force transducers shall be summed and filtered using ISO 6487:2000 CFC 600. The peak force of this sum should be between and including 2.2 and 2.7 kN, and occur between and including 10.0 and 12.3 ms.

5.12 Pelvis

- 5.12.1 The dummy is seated on a flat, horizontal, rigid surface with no back support. The thorax is positioned vertically while the arms and legs are positioned horizontally.
- 5.12.2 The impactor is a pendulum with a mass of 23.4 ± 0.2 kg and diameter of 152.4 ± 0.25 mm with an edge radius of 12.7 mm ⁽¹⁾. The impactor is suspended from rigid hinges by eight wires with the centre line of the impactor at least 3.5 m below the rigid hinges (see Figure 4).
- 5.12.3 The impactor is equipped with an accelerometer sensitive in the direction of impact and located on the impactor axis.
- 5.12.4 The impactor should freely swing onto the pelvis of the dummy with an impact velocity of 4.3 ± 0.1 m/s.
- 5.12.5 The impact direction is perpendicular to the anterior-posterior axis of the dummy and the axis of the impactor is aligned with the centre of the H-Point back plate.
- 5.12.6 The peak force of the impactor, obtained from the impactor acceleration filtered using ISO 6487:2000 CFC 180 and multiplied by the impactor mass, should be between and including 4.4 and 5.4 kN, and occur between and including 10.3 and 15.5ms.
- 5.12.7 The pubic symphysis force, filtered using ISO 6487:2000 CFC 600, should be between and including 1.04 and 1.64 kN and occur between and including 9.9 and 15.9 ms.

5.13 Legs

- 5.13.1 No dynamic certification procedure is defined for the legs

⁽¹⁾ Pendulum corresponding with American Code of Federal Regulation 49 CFR Chapter V Part 572.36(a) (10-1-00 Edition) (See also Figure 4).

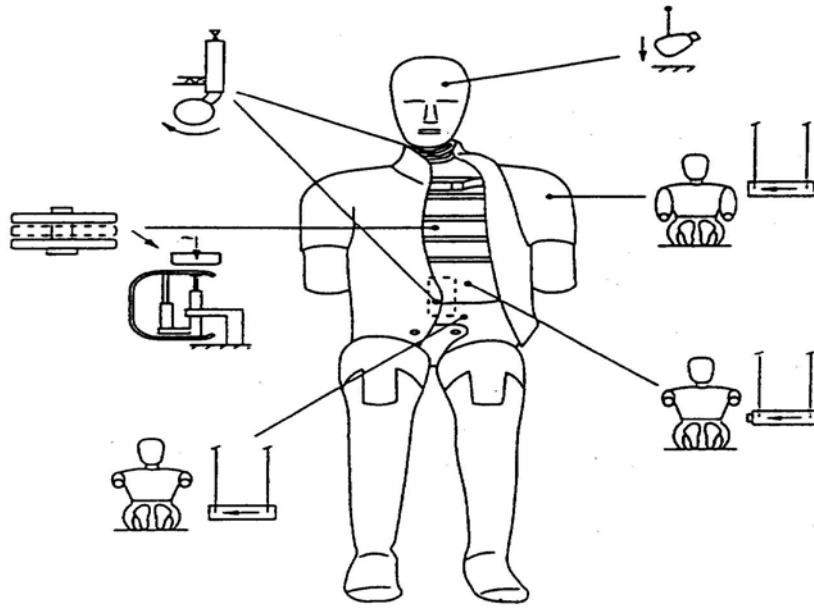

Figure 3

Overview of Dummy Certification Test Set-up

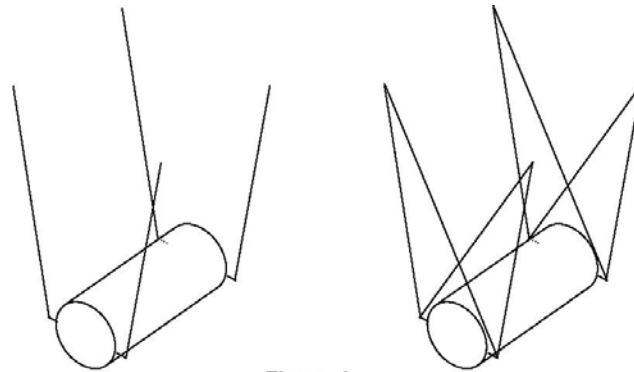

Figure 4

23.4 kg Pendulum Impactor Suspension
Left: Four Wires Suspension (Cross Wires Removed)
Right: Eight Wires Suspension

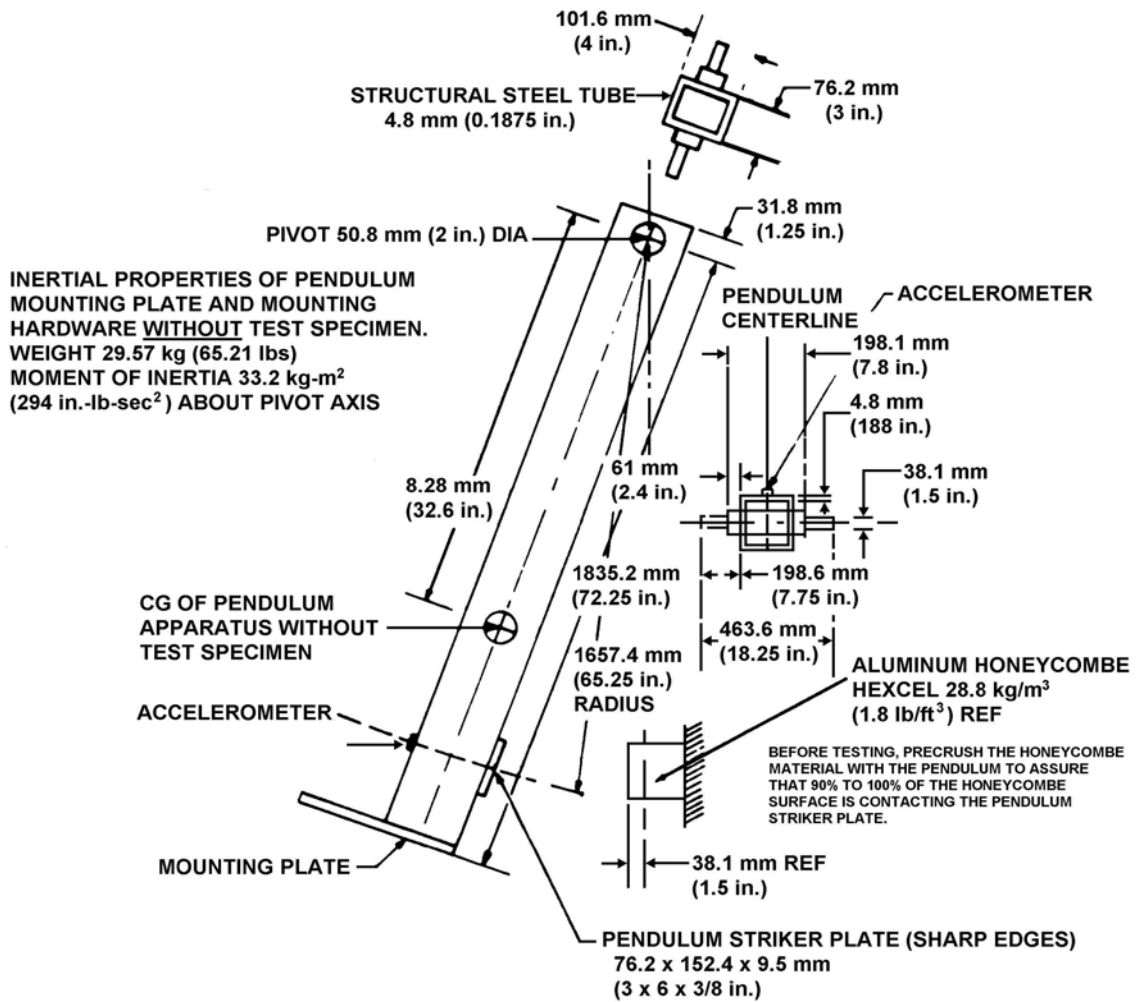

Figure 5

Neck Pendulum Specification According to
American Code of Federal Regulation
(49 CFR Chapter V Part 572.33)

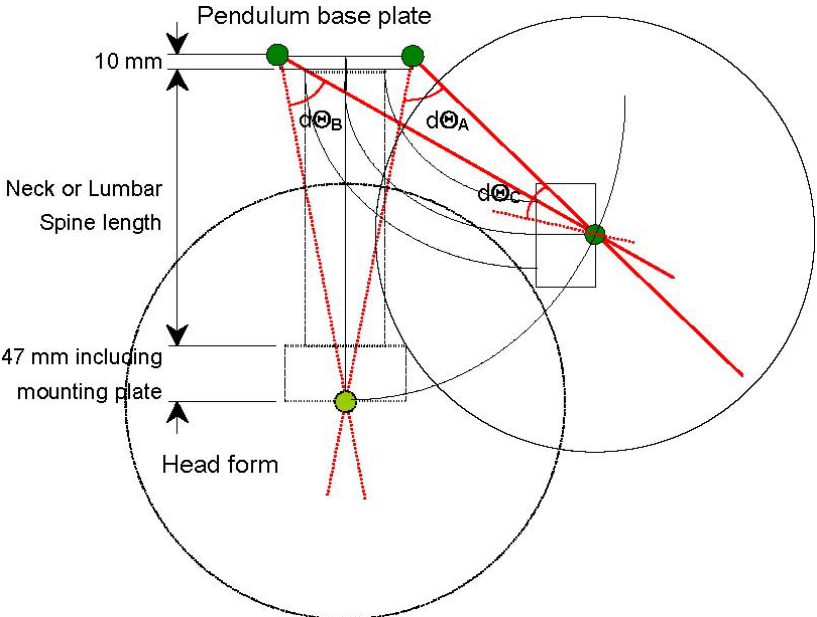

Figure 6

**Neck and Lumbar Spine Certification Test Set-up
(Angles $d\theta_A$, $d\theta_B$ and $d\theta_C$ Measured with Headform)**

**Pendulum velocity change corridor for neck certification
Velocity in [m/s]**

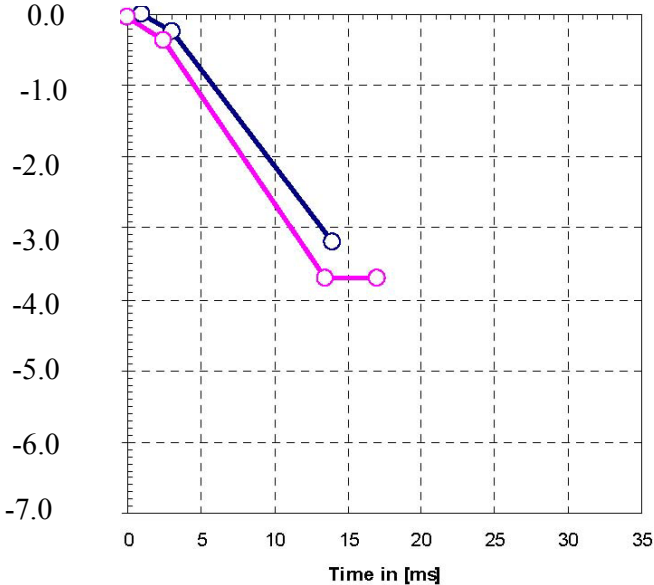
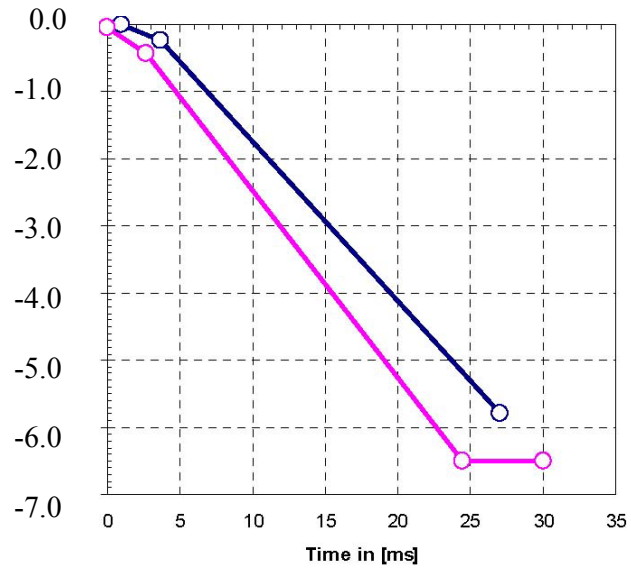

Figure 7

**Pendulum Velocity Change – Time Corridor
for Neck Certification Test**

Pendulum velocity change corridor for lumbar spine certification



Velocity in [m/s]
Figure 8

Pendulum Velocity Change – Time Corridor for Lumbar Spine Certification Test

ANNEX 4 (A)
(See Annex 1-6.1)

INSTALLATION OF THE SIDE IMPACT DUMMY

1. GENERAL

- 1.1. The side impact dummy to be used for the following installation procedure is described in Annex 3 (A) to this standard.

2. INSTALLATION

- 2.1. Adjust the leg joints so that they just support the leg when it is extended horizontally (1 to 2 g).
- 2.2. Clothe the dummy in form-fitting cotton-stretch underwear with short sleeves and mid-calf length trousers. Each foot is equipped with a shoe.
- 2.3. Place the dummy in the outboard front seat of the impacted side as described in the side impact test procedure specification.
- 2.4. The plane of symmetry of the dummy shall coincide with the vertical median plane of the specified seating position.
- 2.5. The pelvis of the dummy shall be positioned such that a lateral line passing through the dummy H points is perpendicular to the longitudinal centre plane of the seat. The line through the dummy H points shall be horizontal with a maximum inclination of $\pm 2^\circ$.
- 2.6. The upper torso shall be bent forward and then laid back firmly against the seat back. The shoulders of the dummy shall be set fully rearward.
- 2.7. Irrespective of the seating position of the dummy, the angle between the upper arm and the torso arm reference line on each side shall be $40^\circ \pm 5^\circ$. The torso arm reference line is defined as the intersection of the plane tangential to the front surface of the ribs and the longitudinal vertical plane of the dummy containing the arm.
- 2.8. For the driver's seating position, without inducing pelvis or torso movement, place the right foot of the dummy on the undepressed accelerator pedal with the heel resting as far forward as possible on the floor-pan. Set the left foot perpendicular to the lower leg with the heel resting on the floor-pan in the same lateral line as the right heel. Set the knees of the dummy such that their outside surfaces are 150 ± 10 mm from the plane of symmetry of the dummy. If possible within these constraints place the thighs of the dummy in contact with the seat cushion.

- 2.9. For other seating positions, without inducing pelvis or torso movement, place the heels of the dummy as far forward as possible on the floor-pan without compressing the seat cushion more than the compression due to the weight of the leg. Set the knees of the dummy such that their outside surfaces are 150 ± 10 mm from the plane of symmetry of the dummy.

ANNEX 4 (B)
(See Annex 1-2.2)

INSTALLATION OF THE SIDE IMPACT DUMMY

1. **GENERAL**
- 1.1. The side impact dummy as described in Annex 3 (B) of this standard is to be used according the following installation procedure.
2. **INSTALLATION**
- 2.1. Adjust the knee and ankle joints so that they just support the lower leg and the foot when extended horizontally (1 to 2 g – adjustment).
- 2.2. Check if the dummy is adapted to the desired impact direction.
- 2.3. The dummy shall be clothed in a form-fitting cotton stretch mid-calf length pant and may be clothed in a form-fitting cotton stretch shirt with short sleeves.
- 2.4. Each foot shall be equipped with a shoe.
- 2.5. Place the dummy in the outboard front seat on the impacted side as described in the side impact test procedure specification.
- 2.6. The plane of symmetry of the dummy shall coincide with the vertical median plane of the specified seating position.
- 2.7. The pelvis of the dummy shall be positioned such that a lateral line passing through the dummy H-Points is perpendicular to the longitudinal centre plane of the seat. The line through the dummy H-Points shall be horizontal with a maximum inclination of $\pm 2^\circ$ ⁽¹⁾.

The correct position of the dummy pelvis can be checked relative to the H-point of the H-point Manikin by using the M3 holes in the H-point back plates at each side of the ES-2 pelvis. The M3 holes are indicated with "Hm". The "Hm" position should be in a circle with a radius of 10 mm round the H-point Manikin.
- 2.8. The upper torso shall be bent forward and then laid back firmly against the seat back (see Note 1). The shoulders of the dummy shall be set fully rearward.
- 2.9. Irrespective of the seating position of the dummy, the angle between the upper arm and the torso arm reference line on each side shall be $40^\circ \pm 5^\circ$. The torso arm reference line is defined as the intersection of the plane tangential to the front surface of the ribs and the longitudinal vertical plane of the dummy containing the arm.

⁽¹⁾ The dummy can be equipped with tilt sensors in the thorax and the pelvis. These instruments can help to obtain the desired position.

- 2.10. For the driver's seating position, without inducing pelvis or torso movement, place the right foot of the dummy on the non-depressed accelerator pedal with the heel resting as far forward as possible on the floor-pan. Set the left foot perpendicular to the lower leg with the heel resting on the floor-pan in the same lateral line as the right heel. Set the knees of the dummy such that their outside surfaces are 150 ± 10 mm from the plane of symmetry of the dummy. If possible within these constraints, place the thighs of the dummy in contact with the seat cushion.
- 2.11 For other seating positions, without inducing pelvis or torso movement, Place the heels of the dummy as far forward as possible on the floor-pan without compressing the seat cushion more than the compression due to the weight of the leg. Set the knees of the dummy such that their outside surfaces are 150 ± 10 mm from the plane of symmetry of the dummy.

ANNEX 5
(See 6.1.2.2)

PARTIAL TEST

1. PURPOSE

The purpose of these tests is to verify whether the modified vehicle presents at least the same (or better) energy absorption characteristics than the vehicle type approved under this standard.

2. PROCEDURES AND INSTALLATIONS

2.1. Reference Tests

2.1.1. Using the initial padding materials tested during the approval of the vehicle, mounted in a new lateral structure of the vehicle to be approved, two dynamic tests, utilising two different impactors shall be carried out (Figure 1).

2.1.1.1. The head form impactor, defined in paragraph 3.1.1, shall hit at 24.1km/h, in the area impacted for the EuroSID head during the approval of the vehicle. Test result shall be recorded, and the HPC calculated. However, this test shall not be carried out when, during the tests described in Annex 1 of this standard:

where there has been no head contact, or

when the head contacted the window glazing only, provided that the window glazing is not laminated glass.

2.1.1.2. The body block impactor, defined in paragraph 3.2.1, shall hit at 24.1 km/h in the lateral area impacted by the EuroSID shoulder, arm and thorax during the approval of the vehicle. Test result shall be recorded, and the HPC calculated.

2.1.2. Approval Test

2.1.2.1. Using the new padding materials, seat, etc. presented for the approval extension, and mounted in a new lateral structure of the vehicle, tests specified in paragraphs 2.1.1.1 and 2.1.1.2, shall be repeated, the new results recorded, and their HPC calculated.

2.1.2.2. If the HPC calculated from the results of both approval tests are lower than the HPC obtained during the reference tests (carried out using the original type approved padding materials or seats), the extension shall be granted.

2.1.2.3. If the new HPC are greater than the HPC obtained during the reference tests, a new full scale test (using the proposed padding/seats/etc.) shall be carried out.

3. TEST EQUIPMENT

3.1. Head Form Impactor (Figure 2)

3.1.1. This apparatus consists of a fully guided linear impactor, rigid, with a mass of 6.8 kg. Its impact surface is hemispherical with a diameter of 165 mm.

3.1.2. The head form shall be fitted with two accelerometers and a speed-measuring device, all capable of measuring values in the impact direction.

3.2. Body Block Impactor (Figure 3)

3.2.1. This apparatus consists of a fully guided linear impactor, rigid, with a mass of 30 kg. Its dimensions and transversal section is presented in Figure 3.

3.2.2. The body block shall be fitted with two accelerometers and a speed-measuring device, all capable of measuring values in the impact direction.

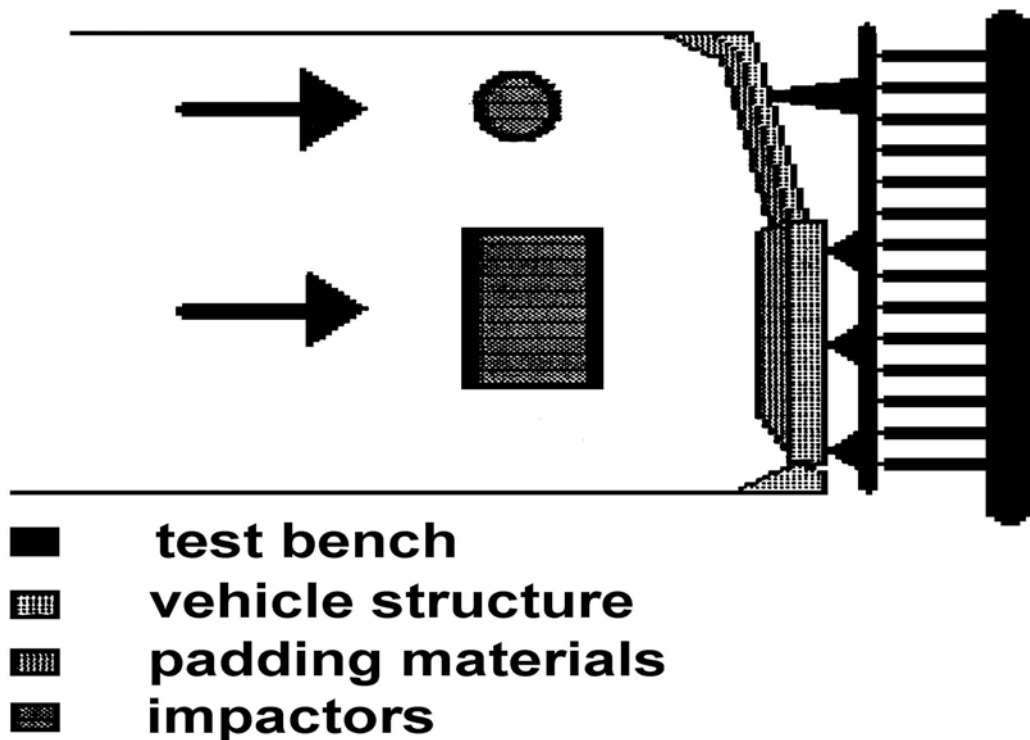

Figure 1

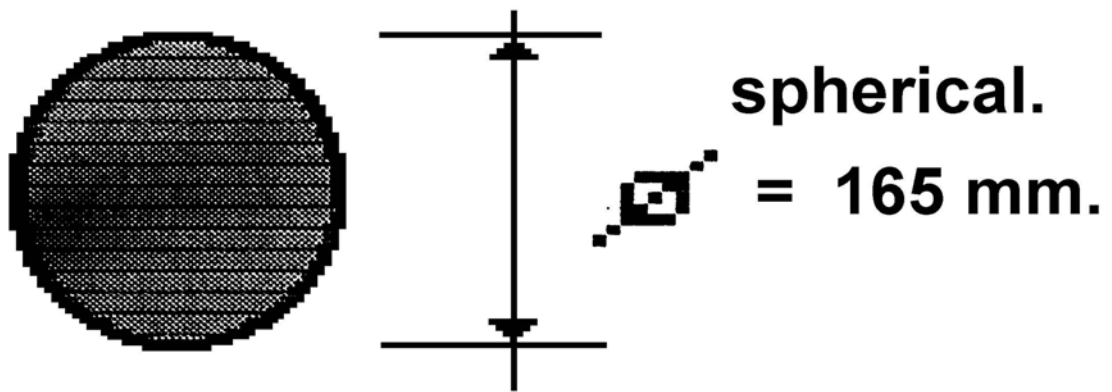

Figure 2
Head Form Impactor

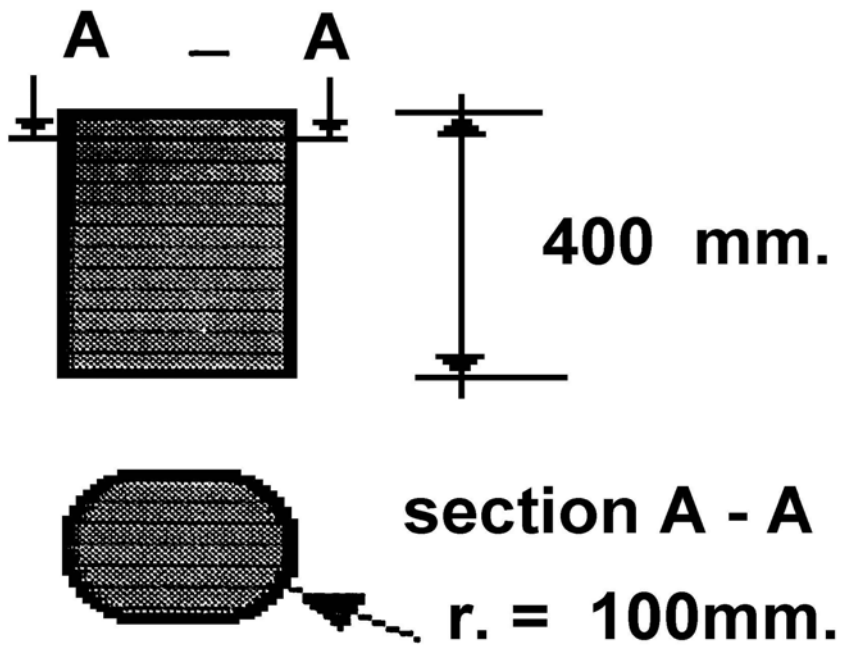

Figure 3
Body Block Impactor

ANNEX 6
(See 6.2)

**GUIDELINE FOR SELECTION OF WORST CASE AND
EXTENSION OF APPROVAL**

1. The guidelines for selection of worst case and extension of approval are as follows:
 - 1.1. **Side sill height from ground:** Configuration with the lowest height should be selected. E.g. Smallest size of tyres. A decrease in sill height from ground by more than 15mm due to change in suspension height etc. will require a re-test.
 - 1.2. **Door trim design and trim material:** Change in trim design and trim material can be certified with a partial test as given in Annex 5.
 - 1.3. **Door construction:** Weakest construction for the front door to be selected. Change in the front door construction e.g. door intrusion beam etc. will require a re-test.
 - 1.4. **Seating position:** If there are two seat strokes with similar seat structure, the seat position resulting in minimum gap between the vehicle structure and the occupant should be selected for the test. Any change in the R-point resulting in lower distance between the intruding structure and occupant will require a re-test
 - 1.5. **R point height from ground:** Decrease in height of the R point from the ground by more than 15mm will require a re-test.
 - 1.6. **Vehicles equipped with side airbags:** Partial test as per Annex 5 can be used to certify an airbag version if the base vehicle (without airbag) meets the requirements.
 - 1.7. **Fuel tank location:** Tank location closest to the intruding structure. A change in the fuel tank location resulting in the fuel tank being located away from the impact side will not require a re-test.

ANNEX 7
(See Introduction)

COMMITTEE COMPOSITION *
Automotive Industry Standards Committee

Chairman	
Shri Shrikant R. Marathe	Director The Automotive Research Association of India, Pune
Members	Representing
Representative from	Ministry of Shipping, Road Transport & Highways (Dept. of Road Transport & Highways), New Delhi
Representative from	Ministry of Heavy Industries & Public Enterprises (Department of Heavy Industry), New Delhi
Shri Chandan Saha	Office of the Development Commissioner, Small Scale Industries, Ministry of Small Scale Industries, New Delhi
Shri Rakesh Kumar	Bureau of Indian Standards, New Delhi
Director Shri D. P. Saste (Alternate)	Central Institute of Road Transport, Pune
Dr. M. O. Garg	Indian Institute of Petroleum, Dehra Dun
Dr. C. L. Dhamejani	Vehicles Research & Development Establishment, Ahmednagar
Representatives from	Society of Indian Automobile Manufacturers
Shri T.C. Gopalan Shri Ramakant Garg (Alternate)	Tractor Manufacturers Association, New Delhi
Shri K.N.D. Nambudiripad	Automotive Components Manufacturers Association of India, New Delhi
Shri Arvind Gupta	Automotive Components Manufacturers Association of India, New Delhi

Member Secretary
Mrs. Rashmi Urdhwareshe
Deputy Director
The Automotive Research Association of India, Pune

* At the time of approval of this Automotive Industry Standard (AIS)