

**AUTOMOTIVE INDUSTRY STANDARD**

**Provisions for Adapted Vehicles of  
categories L1, L2, L5M and Tricycles**

PRINTED BY  
THE AUTOMOTIVE RESEARCH ASSOCIATION OF INDIA  
P.B. NO. 832, PUNE 411 004

ON BEHALF OF  
AUTOMOTIVE INDUSTRY STANDARDS COMMITTEE

UNDER  
CENTRAL MOTOR VEHICLE RULES – TECHNICAL STANDING COMMITTEE

SET-UP BY  
MINISTRY OF ROAD TRANSPORT and HIGHWAYS  
GOVERNMENT OF INDIA

April 2024

## INTRODUCTION

The Government of India felt the need for a permanent agency to expedite the publication of standards and development of test facilities in parallel when the work on the preparation of the standards is going on, as the development of improved safety critical parts can be undertaken only after the publication of the standard and commissioning of test facilities. To this end, the erstwhile Ministry of Surface Transport (MOST) has constituted a permanent Automotive Industry Standards Committee (AISC) vide order No. RT-11028/11/97-MVL dated September 15, 1997. The standards prepared by AISC will be approved by the permanent CMVR Technical Standing Committee (CTSC). After approval, the Automotive Research Association of India, (ARAI), Pune, being the Secretariat of the AIS Committee, has published this standard. For better dissemination of this information ARAI may publish this document on their web site.

Motor Vehicle Amendment Act 2019 has introduced terminology of Adapted Vehicles in section 2 and alteration provisions under section 52 thereof. In 59<sup>th</sup> meeting of CMVR TSC held on 18<sup>th</sup> February 2021 need to formulate procedure for adapted vehicles of two and three wheeled categories was highlighted. This standard has been formulated covering adaptations for vehicle of categories L1, L2 and L5M covering requirements for accommodation and accessibility for Person with disability and passengers of reduced mobility.

Vehicle selection for adaptation shall be done very thoughtfully, since each model of categories L1, L2 and L5M may not suitable for adaptation. This standard is intended to address mobility and self-reliance needs of persons with reduced mobility. Various parameters considered for adaptations are:

1. In a family person who rides/ drives vehicle (driver) may be with reduced mobility and using wheel chair or may have reduced upper limb function, however other family members may be with normal mobility and function;
2. To have vehicle with provision for mobility of passenger with reduced mobility (wheel chair user or elderly people without limb disability);
3. Combination of above 1 and 2;
4. Elderly person may be requiring additional space facilitating boarding and alighting vehicle.
5. Few optional features are recommended instead of mandatory keeping cost involved in adaptations;
6. Intended occupants with reduced mobility can have entry from side or rear of vehicle in case of three wheeled vehicles.

There is no direct reference international standard, however while preparation of this standard considerable assistance is derived from two-wheeler adaptation procedure prepared previously by AISC and notified by erstwhile MoSRTTH as resolution No. RT-11012/12/01-MVL dated 23<sup>rd</sup> July 2008,

which is incorporated as Part A of this standard. Part A has two-wheeler adaptation provisions in the form of Ad-on controls or secondary controls and further addition of allowable minor modifications.

Part B has adaptation provisions for vehicles of category L5M in the form of Ad-on controls or secondary controls and allowable minor modifications. L5M allowable modifications has also drawn references from advisory issued MoRTH (No. RT-11036/06/2019-MVL dated 28<sup>th</sup> February 2019) For testing of the wheelchair docking systems ISO 10542 is appropriately referred. Wheelchair accommodation provisions are appropriately referred.

Part C has adaptation provisions for Tricycles having battery power above 250 Watt. In this part IS 17154: 2019 Battery Operated Motorised Tricycle - Specification is appropriately referred.

The AISC panel and the Automotive Industry Standards Committee (AISC) responsible for preparation of this standard are given in Annexure 1 and Annexure 2 respectively.

**Photographs for Part A modifications as example only**  
 (Photographs are provided only for illustrative purpose and does not cover all the Part A adaptations)

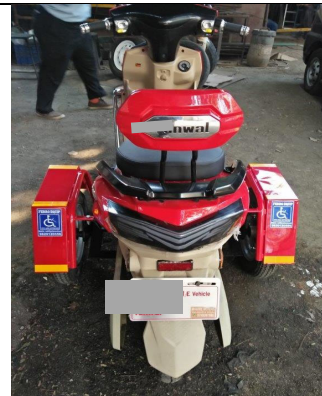

**Photographs for Part B modifications as example only**

(Photographs are provided only for illustrative purpose and does not cover all the Part B adaptations).



**Photographs for Part C modifications as example only**  
 (Photographs are provided only for illustrative purpose and does not cover all the Part C adaptations)

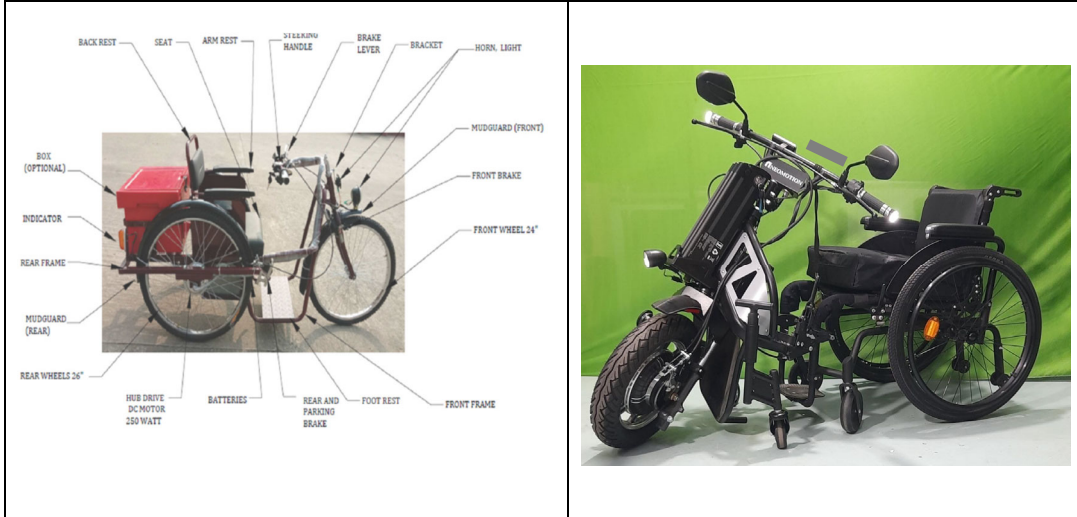

**Provisions for Adapted Vehicles of categories  
L1, L2, L5M and Tricycles**

<b>Clause/ Annex No.</b>	<b>Contents</b>	<b>Page No.</b>
1.	Scope	1/39
2.	Technical and safety requirements	3/39
Part A	Procedure for approval of retro fitment/ Adaptation kit for two wheeled vehicle for physically challenged person	5/39
Annexure A-1	Technical information to be submitted by the retro fitment kit manufacturer	11/39
Annexure A-2	Type of Physical Disability and Modifications thereof	12/39
Part B	Adaptations and approval of L5M three wheelers	13/39
Annexure B-1	List of minor allowable modifications for vehicle adaptation as per this Standard	14/39
Annexure B-2	Wheel Chair Accommodation and Vehicle Accessibility Requirements	16/39
Annexure B-3	Requirements for testing the wheelchair tie-down and Occupant restraint system	18/39
Annexure B-4	Requirement for Hill-hold or Sensible Braking System (SBS) for L5M category	20/39
Annexure B-5	Technical specifications to be provided by vehicle manufacturer / retro-fitter for Approval as per Part B	22/39
Part C	Adaptations and approval of battery-operated Motorized tricycle- Specification	23/39
Annexure C-1	Relevant Indian standards on bicycle components	32/39
Part D	Vehicle adaptation legal provisions made by the Central Government of India recently, facilities in India and good engineering practices	33/39
Annexure D-1	Standard Operating Procedure for adaptations as per part A	36/39
Annexure 1	Composition of AISC panel on Adapted vehicles	37/39
Annexure 2	Committee composition Automotive Industry Standards Committee	39/39

## Provisions for Adapted Vehicles of categories L1, L2, L5M and Tricycles

### 1.0 SCOPE

The provisions of this code are applicable to following adapted vehicles:

Part A: Provisions for vehicle adaptation when minor modifications are carried out in already type approved vehicle by introducing secondary control(s) and/or allowable minor modifications as listed in Part A so as Person with disability (with limb disability as specified in Part A) can drive adapted vehicle of categories L1 and L2.

Part B: Adaptation provisions for vehicles of category L5M in the form of Ad-on controls or secondary controls and allowable minor modifications and vehicle accessibility provisions.

Part C: Adaptation provisions and approval of battery-operated Tricycles having motor power above 250 watt and upto 500 watt.

Part D: Information on: vehicle adaptation recent legal provisions; and panel's recommendations. Part D is purely informative and it does not have direct contents specifying requirements for Type Approval of adapted vehicles as per this standard.

Modifications specified in this standard may be carried out for vehicles driven by person without disability, however in such cases, it will be considered as retro-fitted vehicle and not an adapted vehicle.

Modifications specified in this standard may be carried out by OEM or retro-fitter.

1.1 **Definitions** - The definitions are for the purpose of this standard.

1.1.1 **"Adapted vehicle"** means a motor vehicle either specially designed and constructed, or to which alterations have been made under sub-section (2) of section 52, for the use of a person suffering from any physical defect or disability, and used solely by or for such person.

(Reference: Motor Vehicle (Amendment) Act 2019 No. 32 of 2019 issued by Ministry of Law and Justice dated 9th August 2019.).

1.1.2 **"Exterior courtesy lamp"** means a lamp used to provide supplementary illumination to assist the entry and exit of the vehicle driver and passenger or in loading operations as applicable for the specific adaptation.



- 1.1.3 **“Person with disability”** means person with limb disability including person with short stature and is eligible to drive adapted vehicle(s) specified in this standard complied with provisions about disability mentioned in this standard and driving licence tests.
- Note:** Person with short stature is as specified in Person with Disability Act 2016. For person with disability, various locomotor disabilities considerations are as specified in Part A of this standard.
- 1.1.4 **"Passenger with reduced mobility"** means all passengers who have a difficulty when using public transport, such as disabled person, wheelchair users, person with limb impairments, elderly person (senior citizens), visually impaired, hearing impaired, short stature.
- 1.1.5 **"Wheelchair user"** means a person who due to infirmity or disability uses a wheelchair for mobility.
- 1.1.6 **"Boarding device"** means a device to facilitate wheelchair access to vehicle, such as ramps, portable ramp, etc.
- 1.1.7 **"Ramp"** means a device to bridge the gap between the floor of driver and /or passenger compartment and the ground or kerb. In its position for use, it includes any surface that may move as part of the ramp deployment or be available for use only when the ramp is in its deployed position and over which a wheelchair is intended to travel.
- 1.1.8 **"Portable ramp"** means a ramp that may be detached from the vehicle structure and capable of being deployed by a driver or passenger and also can be carried in the vehicle.
- 1.1.9 a) **"Demountable seat"** means a seat that can be easily detached from the vehicle.
- b) **“Foldable seats”** are seats with easy entry mechanism as specified in IS15546 as amended time to time.
- 1.1.10 **“Swivel Seats”** means the passenger/ driver seat that can swivel to 90 degrees in either direction in L5M category. Swivel seat must have a locking system in place.
- 1.1.11 **Secondary controls** are ad-on dual controls, which does not change basic control or systems of vehicle. Performance of Secondary controls are verified as per Part A of this standard.
- 1.1.12 **Docking tie-down device or docking securement device** means assembly of fixtures and components designed for installation in motor vehicles for the purpose of securing a wheelchair by engaging with, and locking onto, securement points on the wheelchair frame or on wheelchair securement adaptors attached to the wheelchair frame.
- NOTE:** Securement of the wheelchair generally occurs automatically during wheelchair engagement with the device in the vehicle, but release of the wheelchair usually requires operation of a mechanical lever or electrical switch.

- 1.1.13 **Twinned wheels** means, in the case of L category vehicles, two wheels mounted on the same axle, the distance between the centres of their areas of contact with the ground is equal to or less than 460 mm. Twinned wheels shall be considered as one wheel.

**Note:** 'axle' means the common axis of rotation of two or more wheels whether power driven or freely rotating, and whether in one or more segments located in the same plane perpendicular to the longitudinal centre-line of the vehicle.

- 1.1.14 **Tricycle:** is defined as a battery operated vehicle with three wheels symmetrically arranged in relation to the longitudinal median plane.

Detachable Tricycle is defined as a tricycle which can split into two halves when "desired by and acted upon" by the user. Wheelchair may constitute rear part of it.

## 2.0 TECHNICAL AND SAFETY REQUIREMENTS

### 2.1 Consideration of Vehicle Age for adaptation

- 2.1.1 While adaptations as per Part A of this standard for Person with disability are being carried out, vehicle having valid registration can be considered for adaptation.

- 2.1.2 When vehicle adaptation is taken up for hire and reward purpose (e.g. wheelchair user passenger transport service, mobile shops are fabricated for self-reliance) and also necessitating allowable structural changes, vehicle upto 5 (five) years age (from its date of registration) and having valid registration can be considered for adaptation

- 2.2 **Change in seating capacity after adaptations:** For the purposes of seating capacity calculations, the mass of the wheel-chair including the user shall be assumed to be 100 kg.

The mass shall be concentrated at the H point of the three- dimensional machine.

The test agency shall also consider the possibility to use electric wheelchair(s), the mass of which, including the user, is assumed to be 250 kg. Any limitation in the passenger capacity resulting from the use of electric wheelchair (s) shall be recorded in the type-approval certificate and an appropriate language thereto shall be included in the certificate of conformity.

Increase in seating capacity after vehicle adaptation or retro-fitment is not allowed.

- 2.3 **EMC/EMI:** Wherever vehicle and /or wheel chairs are added with electronic system(s), or ESA they shall comply with requirements specified in AIS-004 (Part 3), as amended from time to time.

- 2.4 **Docking Systems:** Wheelchair docking is an alternative system for securing the wheelchair to the floor of a vehicle. Docking systems use an automated clamp like device mounted to the floor that locks on to a pin or dedicated member that is added to the frame of the wheelchair. Docking systems utilize mechanical and / or electronic push- button control console for quickly locking and releasing the wheelchair, eliminating the need for tie-down straps. Wherever docking systems are provided they shall comply with relevant requirements of this standard.
- 2.5 **Exterior courtesy lamp:** wherever these lamps are provided they shall meet relevant requirements AIS-008 (Rev. 2) as amended from time to time.
- 2.6 **Ramp conspicuity lamp:**
1. Presence: Required on L5 category vehicles when ramp is in use.
  2. Number: No special requirements
  3. Arrangement: No special requirement.
  4. Position: No special requirement  
(Ramp shall have adequate illumination when lit)
  5. Geometric visibility: No special requirement.
  6. Orientation: No special requirement.
  7. Light source: No special requirement
  8. Color of light emitted: No special requirement
  9. Electrical connections: Control shall be by manual switches under the control of the driver or automatically controlled when ramp is in use.

**PART A****PROCEDURE FOR APPROVAL OF RETRO FITMENT/  
ADAPTATION KIT FOR TWO WHEELED VEHICLE  
FOR PHYSICALLY CHALLENGED PERSON****0.0 SCOPE**

Part A of this standard is applicable to address modifications in already type approved vehicles of categories L1 and L2. Modifications specified in this part can be undertaken by retro-fitter or OEM.

**1.0 OBJECTIVE**

To provide stability to the 2 wheeled vehicle, so that the person with lower limb disabilities can drive the vehicle without having to balance the same.

**2.0 POSSIBLE MODIFICATIONS IN THE VEHICLE****2.1 Fitment of Side Car for carriage of a passenger:**

- a) 2-wheeled vehicle can be modified by fitment of a sidecar on the left side of the vehicle.
- b) While carrying out such a modification, it shall be ensured that minimum changes are made on the basic structure of the vehicle.
- c) In case the original vehicle has any foot controls (such as accelerator, brake, clutch or gear shift), such controls shall be adapted for operation by hand.
- d) The vehicle shall have device to intentionally lock the wheels in order to prevent rolling of vehicle (in situations like alighting the vehicle, stopping the vehicle on the gradient, etc).
- e) The vehicle shall have either hand start or electric-starting mechanism.
- f) Clamping arrangements shall be provided for carrying person's aids/ crutches etc.

**2.2 Fitment of additional two wheels at the rear.**

- a) 2-wheeler vehicle can be modified by fitment of additional two wheels to provide balancing/ stability to the vehicle. The additionally fitted wheels may have preferably the same size and specification of the original rear wheel.
- b) While carrying out such a modification, it shall be ensured that minimum changes are made on the basic structure of the vehicle.

- c) In case original vehicle has any foot controls (such as accelerator, brake, clutch or gear shift), such controls shall be adapted for operation by hand.
- d) The vehicle shall have device to intentionally lock the wheels in order to prevent rolling of vehicle (in situations like alighting the vehicle, stopping the vehicle on the gradient, etc.).
- e) The vehicle shall have either hand start or electric-starting mechanism.
- f) Clamping arrangements shall be provided for carrying person's aids/ crutches etc.

### 2.3 **Fitment of Side Car / carriage for transport of goods:**

- a) L2 vehicle can be modified by fitment of a side car/ carriage on the left side of the vehicle.
- b) While carrying out such a modification, it shall be ensured that minimum changes are made on the basic structure of the vehicle.
- c) In case the original vehicle has any foot controls (such as accelerator, brake, clutch or gear shift), such controls shall be adapted for operation by hand.
- d) The vehicle shall have device to intentionally lock the wheels in order to prevent rolling of vehicle (in situations like alighting the vehicle, stopping the vehicle on the gradient, etc.)
- e) The vehicle shall have either hand start or electric-starting mechanism.
- f) Clamping arrangements shall be provided for carrying person's aids/ crutches
- g) Side car/carriage may have foldable or flexible cover to confine or secure the cargo.
- h) Maximum load carried shall be limited to 50 kg.
- i) Max. dimensions of load shall not exceed (Length \* width \* height) or load shall not be projecting outside of side car load carriage space.

### 2.4 **Retro-fitment of twinned wheel kit in place of a front wheel**

- a) Design outer diameter of the tyres in twinned wheel retro-fitment kit shall be same as original front wheel design outer diameter.
- b) Tyre and wheel rims in twinned wheel retro-fitment kit shall be compliant with IS 15627 and AIS-073/ IS 16192.
- c) Design width of the tyres in twinned wheel retro-fitment kit shall not be bigger than original front wheel tyre width.
- d) Twinned wheel retro-fitment kit may have independent suspensions in case of two-wheeler modification.

### 3.0 APPROVAL OF RETRO FITMENT/ ADAPTATION KIT

#### 3.1 Application for Approval

Kit manufacturer shall submit the already type approved vehicle model fitted with retro fitment/ adaptation kit as specified in this standard along with technical information as per details given in Annexure A.

### 4.0 REQUIREMENTS

The vehicle model fitted with retro-fitment / adaptation kit shall be tested for:

#### 4.1 Functional Brake Test

Vehicle shall be driven on a normal city road at 50 kmph speed (as indicated on speedometer). Both brakes (front and rear) shall be applied together and the stopping behavior of the vehicle shall be checked. During this test, the vehicle shall not show any instability or unsafe condition. Stopping distance shall be verified as per CMV Rule 96(8).

#### 4.2 Functional Gradeability Test

The vehicle shall be driven on the minimum 7-degree gradient. While negotiating the gradient, brakes shall be applied. The vehicle shall not skid and roll back. On release of brake, the vehicle shall be able to easily climb the gradient.

#### 4.3 Fixing of Retro-Reflective Tape

- 4.3.1 Retro-reflective tape, red in colour and having minimum width of 20 mm, shall be affixed running across the width on the rear side of the sidecar or on the additional wheels (as the case may be) to indicate the presence of additional fitment and the width of vehicle from the rear. (See Figure 1).

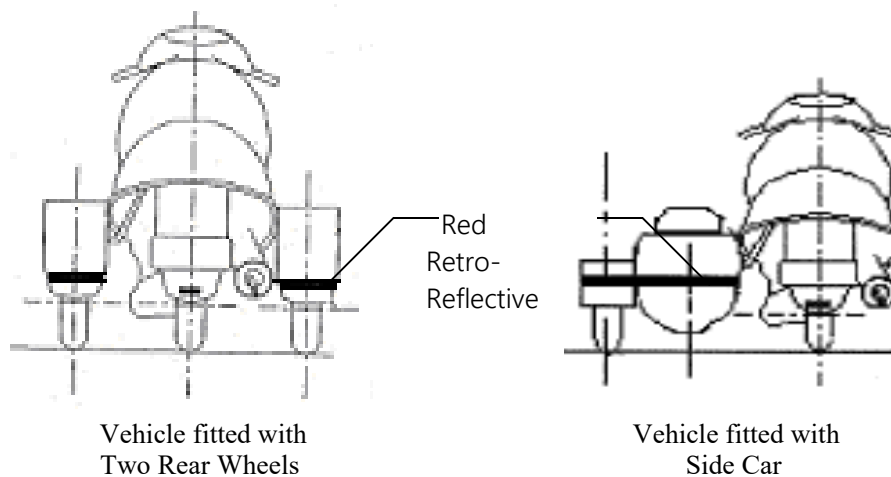

**Figure 1**

4.3.2 Retro-reflective tape, white in colour and having minimum width of 20 mm, shall be affixed running across the width on the front side of the sidecar or on the additional wheels (as the case may be) to indicate the presence of additional fitment and the width of vehicle from the front. (See Figure 2).

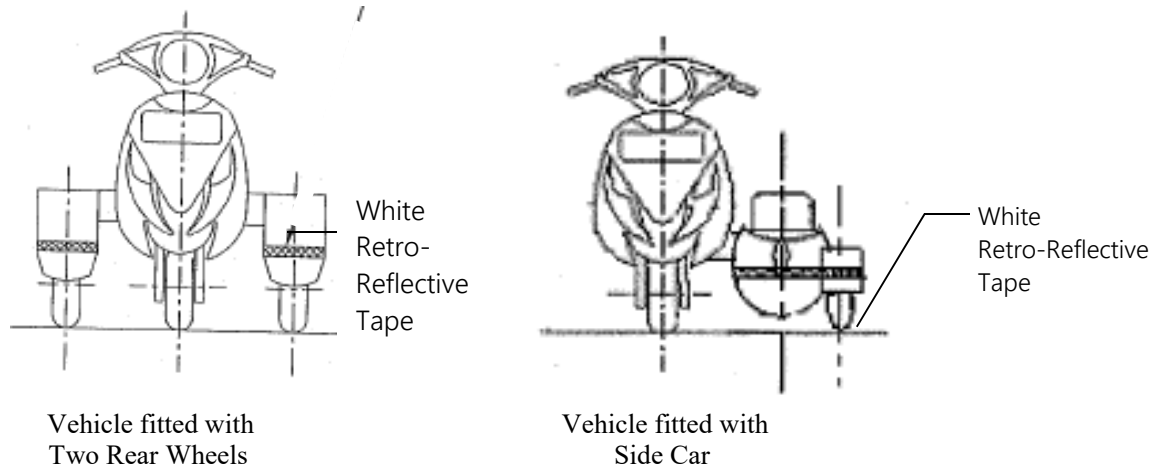

Figure 2

4.4 Identification Symbol

The vehicle shall carry following symbol in the front and at rear, indicating that the vehicle is meant for driving by a physically challenged person. The symbol shall be made up of retro-reflective material (tape).

Wherever space constraint is there, square blue background below may be provided in circular shape having diameter 80 mm.

4.5 Functional maneuverability test

The vehicle shall be able to negotiate the steering course as per figure of '8'

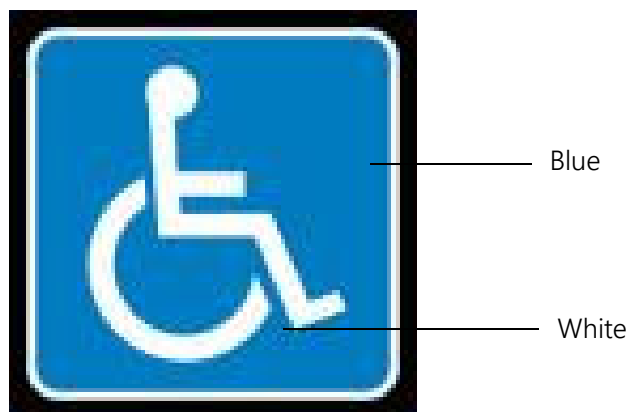

Size : 80 x 80 mm

Figure 3

Affixing of symbol in case three wheelers shall not obstruct drivers' field of vision.



**Figure 3A**

**For hearing impaired person using hearing aid shall affix symbol as per Figure 3A with size 80 x 80 mm**

#### **5.0 APPROVAL OF WORKSHOPS FOR THE FITMENT OF APPROVED KITS**

The kit manufacturer shall identify the workshops, which shall carry out the fitment on his behalf.

This shall be done on the basis of:

- Competence.
- Availability of necessary of equipment.
- Experience in the relevant field.
- Trained manpower etc.

#### **6.0 TYPES OF PHYSICAL DISABILITIES THAT CAN BE CONSIDERED FOR USE OF ABOVE VEHICLES WITH RETRO FITTED KIT**

Authorized medical practitioner shall examine type of physical disabilities of the person and assess the degree of disability based on specific norms. Physical disabilities above 25% may be acceptable for driving a adapted vehicle fitted with retro fitment kit.

Following are some typical disabilities of limbs, for consideration for driving:

- a) Left leg (partial or full): May be considered
- b) Right leg (partial or full): May be considered
- c) Both leg (partial or full): May be considered
- d) Left /right (partial or full) hand: May be considered.
- e) Both hands (partial or full): Not recommended under normal situations. May be considered under special circumstances.



- f) Combination of one lower limb and upper limb: May be considered under special circumstances.
- g) Person with short stature: May be considered.
- h) Person with spine disability: May be considered.

Following aspects may be considered for certifying the person with physical disability for his driving abilities of the vehicle fitted with retro fitment kit.

- Vision
- Muscle strength, flexibility and range of motion
- Co-ordination and reaction time
- Judgment and decision making abilities
- Ability to drive with adaptive equipment as specified above.

Medical report may contain specific recommendations on driving requirements or restrictions.

#### **7.0 REGISTRATION OF VEHICLE FITTED WITH RETRO FITMENT KIT AND OFFERING DRIVING LICENSE.**

Road Transport Authorities (RTO) shall register the vehicle fitted with approved retro fitment kit for a person with physical disabilities as adapted vehicle compliance to:

- Valid certificate of retro fitment kit from authorized Test Agency.
- Valid certificate of authorized workshop for the fitment of approved retro fitment kit.
- Medical fitness certificate from authorized medical practitioner.
- Driving test.

#### **8.0 FAILURE MODE EFFECT ANALYSIS (FMEA) AND TROUBLE-SHOOTING GUIDELINES AS SUBMITTED BY THE INSTALLER SHALL BE EXAMINED.**

8.1 Retro-fitment kit installer shall provide user guide (instruction manual) to vehicle owner involving at least following instructions:

1. Name of Retro-fitter and his contact details, including mobile No./helpline No.
2. Ways for effective use of secondary controls fitted while vehicle adaptation.
3. Remedies on possible failures.

## ANNEXURE: A-1

**TECHNICAL INFORMATION TO BE SUBMITTED BY  
THE RETRO FITMENT KIT MANUFACTURER**

1.0	Retro fitment kit Manufacturers name and address	
	Tel. No.	
	Fax No.	
	E mail address	
	Contact person	
	Website address, if any.	
2.0	Vehicle Model selected for retro fitment.	
3.0	Authenticated drawings, in duplicate, with following details a) Kit identification / model No. b) List of kit components c) Details of individual component and assembly of kit on the vehicle d) Locations and fixing details for person's aids / crutches etc.	
4.0	Detailed explanation about safety in case of accidental failure of modified controls / other mechanisms	
5.0	Instruction / Maintenance manual	
6.0	Any other relevant information	

## ANNEXURE A-2

Sr. No.	Type of Physical Disability	Recommended modifications
(1)	(2)	(3)
1	Impairment in both legs*.	Fitment of side-wheels or side car.
2	Impairment in left leg*.	Fitment of side-wheels or side car.
3	Impairment in right leg*	Fitment of side-wheels or side car.
4	Impairment in Left / right hand (partial or full)	Pedal extension or provisions, so that foot controls may be operated by hand.
5.	For short height person	Pedal extension and seat modification as per height.
6.	For person with spine disability	Fitment of seats to have back support and resting handles
	<p data-bbox="423 942 1321 1037">*In case of twinned wheel two wheelers or L1-1 category vehicles as per AIS-183, vehicle without modification can be treated as suitable for persons with lower limb disability.</p> <p data-bbox="423 1079 1321 1205">When person with lower limb (leg below knee) disability is using prosthetic leg and in position to operate the controls safely and can easily rest his prosthetic leg in case of temporary halting is required, fitment of side-wheels or side car is not required for vehicle adaptation.</p> <p data-bbox="423 1247 1321 1352">Hearing impaired person having corrected hearing impairment by use of hearing aids, can drive normal vehicle and shall affix symbol as specified in Figure 3A.</p>	

**PART B**  
**ADAPTATIONS AND APPROVAL OF L5M**  
**THREE WHEELERS**

**1.0 SCOPE**

Part B of this standard is applicable to address modifications in already type approved vehicles of category L5M. Modifications specified in this part can be undertaken by retro-fitter or OEM.

**2.0 REQUIREMENTS**

- 2.1 List of minor allowable modifications shall be as per Annexure B-1.
- 2.2 Wheel chair accommodation and Vehicle accessibility requirements as per Annexure B-2.
- 2.3 Requirements for testing the wheelchair tie-down and occupant restraint system as per Annexure B-3.
- 2.4 Requirement for Hill-hold or Sensible Braking System (SBS) as per Annexure B-4.
- 2.5 Technical specifications to be provided by vehicle manufacturer / retro-fitter for Approval as per Annexure B-5.

**ANNEXURE B-1****List of Minor Allowable Modifications for Vehicle Adaptation  
as per this Standard**

- 1.0 When following minor modifications are already approved as a part of Adaptation Retro-fitment kit for specific vehicle model / OE genuine parts, further testing while adaptation as per part A is not required:
- 1.1 Increase of door opening, where door stopper length is to be increased and / or door hinge is to be modified.
- 1.2 Fitment of light switch to operate lights / wipers in dual / tandem to the original system of the vehicle.
- 1.3 Adaptation and fitment of Swivel (Rotary) cum transfer seat mechanism in the rear seat of a suitable vehicle.
- 1.4 Fitment of mechanical lever to operate the original light control levers from left side to right side and vice versa in cases of one hand disability.
- 1.5 Fitment of switch on the flooring to operate the lights as required for cases of persons with either hand disability.
- 1.6 Fitment or adaptations of telescopic portable ramps for loading wheelchairs into the vehicle.
- 1.7 Fitment of system which will act as parallel system for signal activation.
- 1.8 Fitment of light for illumination, so that ramp will be properly visible after opening of door.
- 1.9 Buzzer while ramp is in use. Portable Ramp may have lights and buzzer.
- 1.10 Folding support (handle) to ease-out standing while egress from vehicle. This is fitted at door lock hook.
- 1.11 Fitment of hand rest to bucket seat.
- 1.12 Increasing seat height.
- 1.13 Increasing seat cushion.
- 1.14 Provision of puncture repair kit.

- 2.0 Allowable alterations in Motor Vehicles by owner of the vehicle without further certification and without modification in Registration Certificate (Ref. No. RT-11036/06/2019-MVL dated 28<sup>th</sup> February 2019 by MoRTH).
- 2.1 Replacement of parts or components by the identical parts or components.
- 2.2 Replacement of parts or components with parts or components with equivalent performance.
- 2.3 Optional parts or components as prescribed by vehicle’s manufacturer.
- 2.4 Following modifications are permissible in the motor vehicles, subject to conditions mentioned below (only relevant criteria reproduced below)

Sr. No.	Changes of parameter	Subject to compliance of the following
1.	Seats:  Deletion of seats	1. Vehicle weight after the alteration / changes not to exceed the permissible Gross Vehicle Weight  2. Seating capacity to remain within the same motor vehicle category
2.	Soft top to hard top or vice versa in L5M vehicles	3. Seating dimensions as per prescribed specifications.  4. Seats fitted should not obstruct other occupant(s)
3.	Side door or bars in passenger area of L5M on right hand side of driver.	5. Folding seats, if fitted, should have auto lock in both used / unused position.  6. Such seats shall be fitted in rows other than first row of the driver.  Such fitments shall not obstruct ingress and egress of the occupants.

- 3.0 Failure mode effect analysis (FMEA) and trouble-shooting guidelines as submitted by the installer shall be examined. Following FMEA and trouble-shooting guidelines are as example only. As per vehicle adaptation these are liable to change.
- 4.0 Retro-fitment kit installer shall provide user guide (instruction manual) to vehicle owner involving at least following instructions:
  - 1. Name of Retro-fitter and his contact details, including mobile number / helpline number.
  - 2. Ways for effective use of secondary controls fitted while vehicle adaptation.
  - 3. Remedies on possible failures.

## ANNEXURE B-2

### Wheel Chair Accommodation and Vehicle Accessibility Requirements

- 1.0 Docking Systems for adapted vehicles: Wherever provided, docking systems shall not cause any obstruction for free movement of wheel chair and its clamps or systems acting as anchorages shall comply with provisions of Annexure C1 of this standard.
- 2.0. **Ramp**
- 2.0.1 General Provisions
- 2.0.1.1 The ramp shall only be capable of operation when the vehicle is at standstill
- 2.0.1.2 Edges on the outside shall be rounded to a radius of no less than 2.5mm. Corners on the outside shall be rounded to a radius of not less than 5mm.
- 2.0.1.3 The useable surface of a ramp shall be at least 800 mm wide. The slope of the ramp, when extended or folded out on to a kerb of 150 mm in height, should not exceed 25%. The slope of the ramp, when extended or folded out to the ground, should not exceed 60%. A kneeling system may be used to achieve this test.
- 2.0.1.4 Any ramp which when ready for use exceeds 1,200 mm in length shall be fitted with a device to prevent the wheelchair rolling off the sides.
- 2.0.1.5 Any ramp shall be capable of operating safely with a load of 300kg
- 2.0.1.6 The outer edge of ramp surfaces available for use by a wheelchair shall be clearly marked with a band of colour 45 mm to 55 mm in width which contrasts visually with the remainder of the ramp surface. The band of colour shall extend along the outermost edge and along both edges parallel to the direction of travel of the wheelchair.
- Marking of any trip hazard or where part of the ramp surface also forms part of the step is permissible
- 2.0.1.7 A portable ramp shall be secure when in its position for use. A portable ramp shall be provided with a suitable position where it can be safely stowed and where it is readily available for use.
- 2.0.2 Modes of Operation
- 2.0.2.1 Deployment and stowage of the ramp may be either manually or power - operated.

- 2.0.3 Additional Technical Requirements for Power-operated Ramps
  - 2.0.3.1 Deployment and stowage of the ramp shall be indicated by flashing yellow lights and an audible signal.
  - 2.0.3.2 Deployment and stowage of the ramp that may create a risk of injury shall be protected by a safety device(s).
  - 2.0.3.3 These safety devices shall stop the movement of the ramp when the ramp is subject to a reactive force not exceeding 150 N. The peak force may be higher than 150 N for a short time provided that it does not exceed 300 N. The reactive force may be measured by any method to the satisfaction of the Test Agency.



## ANNEXURE B-3

### Requirements for Testing The Wheelchair Tie-Down and Occupant Restraint System

#### 1.0 Definitions

- 1.1. **Test wheelchair (TWC):** SWC or SWM wheelchair that is used to test wheelchair-tiedown and occupant-restraint systems
- 1.1.1 **Surrogate wheelchair (SWC)** means rigid, reusable device that conforms with Appendix C-1a of this standard and that is used to simulate a wheelchair for the purpose of testing wheelchair tie-down and occupant-restraint systems
- 1.1.2 **Specific wheelchair model (SWM)** make or model of wheelchair for which the WTORS is specifically designed
- 1.2. Point P is a reference point that lies at the cross-sectional centre of a cylinder of diameter 100 mm and length 200 mm, positioned with the longitudinal axis perpendicular to the wheelchair reference plane such that the curved surface of the cylinder contacts the back support and the upper surface of the seat. See figure below.

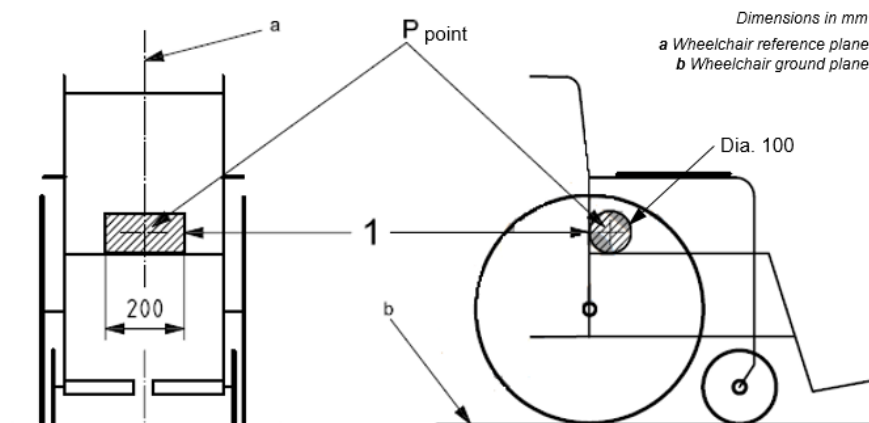

#### 2.0 General requirements

- 2.1. Each wheelchair location shall be provided with anchorages to which a wheelchair tie-down and occupant restraint system (WTORS) shall be fitted.
- 2.2. The wheelchair occupant's lower belt anchorages shall be located in accordance with UN Regulation No 14.07, paragraph 5.4.2.2, relative to Point P on the SWC, when placed in the travelling position designated by the manufacturer. The upper actual anchorage(s) shall be located at least 1100 mm above the horizontal plane passing through the points of contact between the rear tyres of the SWC and the vehicle floor. That condition shall still be satisfied after the test carried out in accordance with point 3 of this Annexure.

- 2.3. An assessment shall be made of the WTORS occupant belt to ensure compliance with the UN Regulation No 16.06, paragraphs 8.2.2 to 8.2.2.4 and 8.3.1 to 8.3.4. 2.4.

### **3.0 Static in-vehicle testing**

- 3.1. Wheelchair occupant restraint anchorages
- 3.1.1. The wheelchair occupant restraint anchorages shall resist the static forces prescribed for occupant restraint anchorages in UN Regulation No 14.07, simultaneously with the static forces applied to the wheelchair tie-down anchorages as specified in point 3.2 of this Annexure.
- 3.2. Wheelchair tie-down anchorages The wheelchair tie-down anchorages shall resist the following forces, for at least 0.2 seconds, applied via the SWC (or a suitable surrogate wheelchair having a wheelbase, seat height and tie-down attachment points in accordance with the specification for the SWC), at a height of 300 +/- 100 mm from the surface on which the SWC rests:
- 3.2.1. In the case of a forward-facing wheelchair, a simultaneous force, coincident with the force applied to the occupant restraint anchorages, of 24.5 kN, and
- 3.2.2. A second test applying a static force of 8.2 kN directed towards the rear of the vehicle.
- 3.2.3. In the case of a rearward-facing wheelchair, a simultaneous force, coincident with the force applied to the occupant restraint anchorages, of 8.2 kN, and
- 3.2.4. A second test applying a static force of 24.5 kN directed towards the front of the vehicle.

**ANNEXURE B-4**

**Requirement for Hill-Hold or Sensible Braking System (SBS) for L5M Category**

1. SBS is applicable for Hydraulic and Air Braking System laid Vehicles. Including ABS and Non-ABS Vehicles. SBS is applicable for Manual, Automatic and Auto Manual Transmission Vehicles.
2. Additional ON/OFF Switch can be provided to enable or disable SBS system.
3. **Technical requirement:** Wherever Hill-hold or Sensible Braking System (SBS) are fitted they shall comply with following provisions.
  - 3.1. **Testing Procedure for Manual Transmission Vehicles**

	<u>18 % Grade - Uphill</u>		<u>18 % Grade – Downhill</u>	
	<b>Vehicle Stationary up to 15 Minutes</b>	<b>Vehicle Roll Back</b>	<b>Vehicle Stationary up to 15 Minutes</b>	<b>Vehicle Roll Front</b>
Service Brake Force to Hold Vehicle Stationary (N)				
"SBS" Activated and Service Brake Dis Engaged (N) at Zero Speed				
"SBS" Activated and Service Brake Dis Engaged in Gear Position (Clutch Engaged) at Zero Speed				
	<b>YES</b>	<b>NO</b>	<b>YES</b>	<b>NO</b>
Data Indicates Compliance				
Comments (If Any)				

**3.2 Testing Procedure for Auto Transmission and Auto Manual Transmission Vehicle**

	<u>18 % Grade – Uphill</u>		<u>18 % Grade – Downhill</u>	
	<b>Vehicle Stationary up to 15 Minutes</b>	<b>Vehicle Roll Back</b>	<b>Vehicle Stationary up to 15 Minutes</b>	<b>Vehicle Roll Front</b>
Service Brake Force to Hold Vehicle Stationary (N)				
"SBS" Activated and Service Brake Dis Engaged (N) at Zero Speed				
"SBS" Activated and Service Brake Dis engaged D Mode (Driving Mode) at Zero Speed				
	<b>YES</b>	<b>NO</b>	<b>YES</b>	<b>NO</b>
Data Indicates Compliance				
Comments (If Any)				

## ANNEXURE B-5

**Technical Specifications to be Provided by Vehicle Manufacturer /  
Retro-Fitter for approval as per Part B**

<b>1.0</b>	<b>Details of vehicle manufacturer / retro-fitter</b>	
1.1	Name & address of the vehicle manufacturer or importer or retro-fitter	
1.2	Telephone / Mobile No.	
1.3	Fax. No.	
1.4	E-mail address	
1.5	Contact person	
1.6	Address of the Plant(s)of manufacture	
1.7	Model Name	
1.8	Variant Name	
1.9	Vehicle Type (Variant (OE) / Retro-fitted)	
1.10	Seating Layout Drawing No.	
1.11	Seating Capacity	
<b>2.0</b>	<b>Overall Vehicle Dimensions (mm)</b>	
2.1	Vehicle length, mm	
2.2	Vehicle width, mm	
2.3	Vehicle height, mm	
2.4	Wheel Base (mm)	
<b>3.0</b>	<b>Docking System provided (Yes/No)</b>	
<b>4.0</b>	<b>Wheelchair</b>	
4.1	Forward facing/ Rearward facing	
4.2	Wheelchair accommodation provisions	
4.2.1	Width	
4.2.2	length	
4.4	Height of wheelchair access door	
4.5	Width of wheelchair access door	
4.6	Foldable or detachable seats in wheel chair area provided (Yes/ No)	
4.7	Type of wheelchair restraint system	
<b>5.0</b>	<b>Wheelchair Electronics provided (Yes/No)</b>	
<b>6.0</b>	<b>SBS system as per Annexure C-2 provided (Yes/No)</b>	

**PART C**  
**ADAPTATIONS AND APPROVAL OF BATTERY OPERATED  
 MOTORIZED TRICYCLE - SPECIFICATION**

**1.0 SCOPE**

This standard specifies the overall dimensions and functional requirements for battery operated tricycle used as conveyance by Person with Disability having disability of lower extremities. Battery operated tricycle is a new form of powered tricycle.

For the purpose of this standard tricycles with maximum speed upto 25 km/h and operated by electric motors providing power above 250 W and upto 500 watt are considered.

Detachable type of tricycles shall comply provisions of clause 6.16 of this Part C.

**2.0 REFERENCES**

ISO 7176 (Parts 1 to 14) on Wheelchairs

The Indian standards (IS) listed below contain provisions which, through reference in this text, constitute provisions of this standard. All standards are subject to revision, and parties to agreements based on this standard are encouraged to investigate the possibility of applying the most recent editions of the standards listed below:

IS 277 : 2018	Galvanized steel strips and sheets ( plain and corrugated) - Specification ( seventh revision)
IS 287 : 1993	Permissible moisture content for timber used for different purposes recommendations ( third revision )
IS 399 : 1963	Classification of commercial timbers and their zonal distribution (revised)
IS 401 : 2001	Preservation of timber - Code of practice (fourth <i>revision</i> )
IS 513 (Part 1): 2016	Cold reduced carbon steel sheet and strip – Part 1 Cold forming and drawing purpose (6 <sup>th</sup> <i>revision</i> )
IS 624 : 2003	Bicycles — Rims — Specification ( <i>fourth revision</i> ) 630 : 2005 Bicycle spokes (plain) and nipples for spokes — Specification ( <i>third revision</i> )

IS 1068 : 1993	Electroplated coatings of nickel plus chromium and copper plus nickel plus chromium — Specification ( <i>third revision</i> )
IS 1331 : 1971	Cut sizes of timber ( <i>second revision</i> )
IS 1573 : 1986	Electroplated coatings of zinc on iron and steel ( <i>second revision</i> )
IS 2039 : 1991	Steel tubes for bicycle and cycle rickshaws — Specification ( <i>second revision</i> )
IS 2414 : 2005	Cycle and rickshaw pneumatic tyres — Specification ( <i>fourth revision</i> )
IS 2415 : 2015 Cycle	— Rubber tubes (moulded/jointed) — Specification ( <i>fourth revision</i> )
IS 2898 : 1976	Specification for steel balls for rolling bearings ( <i>first revision</i> )
IS 4454 (Part 1) : 2001	Steel wires for mechanical springs: Part 1 Patented and cold drawn steel wires — Unalloyed ( <i>third revision</i> )
IS 4923 : 2017	Hollow steel sections for structural use — Specification ( <i>third revision</i> )
IS 7298 : 1973	Cotton webbing, proofed and un proofed
IS 8698 : 1984	Expanded vinyl coated fabrics ( <i>first revision</i> )
IS 16305 : 2017	Cycle — Glossary of terms used in the bicycle industry

### 3.0 NOMENCLATURE

For the purpose of this standard, the nomenclature various parts as given in Fig. 1 and IS 16305: 2017 shall apply.

## 4.0 SHAPE AND DIMENSIONS

The typical shape and dimensions of the battery operated tricycle shall be as shown in Fig. 1 and Table 1. However, ISO 7176 compliant wheelchair, dimensions specified in Table 1 shall not be applicable.

<b>Table 1 Dimensions of Battery Operated Tricycle</b> (Clause 4)	
<b>Nomenclature</b>	<b>Size (in mm)</b>
Overall length	1730 ± 50
Overall width	730 ± 50
Overall height	900 ± 50
Width of foot rest	200 ± 10
Length of foot rest	450 ± 10
Clearance of foot rest from ground	145 ± 25
Armrest height from seat	250 ± 25
Seat length	410 ± 25
Seat width	450 ± 25
Back height from seat	400 ± 25
Height of rear wheel supporting frame	330 ± 25
<b>Notes:</b>	
1.	Steering handle design can be made according to user comfort.
2.	Dimensions of foot rest and back height from seat modified as per user comfort.

## 5.0 MATERIAL

### 5.1 Tubing

The tube used in the frame work of tricycle shall confirm to ERW (C1, C2 or C3) quality specified in IS 2039:1991.

### 5.2 Standard Tricycle Components

Standard components used in the fabrication of tricycle shall be made to the relevant Indian standards on bicycle components. List of relevant Indian Standards on bicycle components is given in Annexure C-1.

### 5.3 Seat and Back Rest

#### 5.3.1 Seat

Seat shall have plywood base of minimum 6 mm thickness and mounted on a wooden frame or base of wooden planks of not less than 10 mm thickness and mounted on a wooden frame or sheet metal base having minimum 1.0 mm thickness suitably formed.

The seat made from any of the above method shall be padded with foam rubber cushioning or other equally suitable material and covered with suitable expanded vinyl coated fabrics conforming to IS 8698 : 1984.



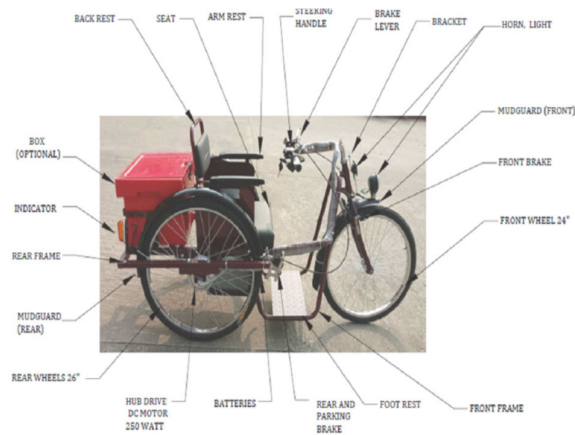

**Figure 1**  
**Battery Operated Motorized Tricycle (Typical)**

### 5.3.2 Back Rest

Back rest shall have plywood support of minimum 3.0 mm thickness and mounted on a wooden frame and the rear side of the back rest shall be covered with plywood of minimum 3.0 mm thickness or shall have sheet metal support having 1.0 mm minimum thickness suitably formed.

Back rest made from any of the above method shall be padded with foam rubber cushioning or other equally suitable material and covered with suitable expanded vinyl coated fabrics confirming to IS 8698 : 1984.

## 5.4 Footrest, Seat Walls and Tool Box

### 5.4.1 Foot Rest

Shall be made from mild steel sheet conforming to class 3 of IS 277 : 2018 having a minimum thickness 1.25 mm or mild steel chequered sheet of thickness  $3 \pm 1.00$  mm excluding raised portion or aluminium alloy sheet of 2 mm minimum thickness or high impact polystyrene or equivalent polymer moulded chequered sheet of thickness 6 mm minimum including raised portion.

### 5.4.2 Seat Walls

Shall be made from mild steel sheet conforming to class 3 of IS 277 : 2018 having a thickness 0.5 mm or mild steel CRA sheet grade '0' IS 513 : 2016 having thickness 0.5mm.

### 5.4.3 Tool Box

Shall be made from mild steel sheet conforming to class 3 of IS 277: 2018 having a minimum thickness 1.25 mm or GI sheet of minimum thickness 0.3 mm.

**Note-** Tool box shall be treated as optional accessories based on agreement between the purchaser and the supplier.

### 5.5 **Spring Wire**

Spring wire used in the brake assembly shall conform to IS 4454 (Part 1) : 2001.

5.6 All other metallic components shall be of mild steel.

### 5.7 **Timber**

Timber for seat frame and other parts shall be seasoned heart wood of any species of timbers specified for furniture and cabinet making in IS 399 : 1963. Heart wood of non-durable timbers and sapwood, if present, shall be given a suitable treatment in accordance with IS 401: 2001. Timber used shall be free from prohibited defects and it shall have not more than the permissible defects as prescribed in IS 1331 : 1971 for grade I timber for non-structural use. Permissible moisture content in timber shall be as recommended in IS 287 : 1993.

## 6.0 **REQUIREMENTS**

### 6.1 **Frame**

The tube used in the frame work shall confirm to ERW quality specified in IS 2039 : 1991 or IS 4923 : 2017. The frame assembly shall be sound and of robust construction. There shall be no sharp edges or unsealed formations.

### 6.2 **Steering Handle Bar**

The steering handle bar shall be fitted to the head tube and it shall be of such length as can be conveniently held by the driver without drooping ahead. The handle shall be light to maneuver and it shall have a suitable plastic or rubber hand grip at its holding end to facilitate proper gripping.

### 6.3 **Driving Mechanism**

Hub drive d.c. motor 250 watt and upto 500 watt powered by Traction batteries shall be fitted in the wheel of tricycle. Ah rating of traction battery, voltage rating of motor and also number of traction batteries can be changed fulfilling the distance range requirement of 1. REESS shall comply with provisions of AIS-038 (Rev. 1).

### 6.4 **Tyres and Tubes**

Tyres and tubes used shall be 24" size for front wheel and 26" for rear wheels, tyres conforming to IS 2414 : 2005 while tubes shall conform to IS 2415 : 2015. Other tyre sizes for front or rear wheel complying with IS 2414 or IS 15627 as applicable (e.g. For front wheel, tires of 8", 10", 12", 16", 18", 24" and for rear wheels, 22", 24", 26", 28").

**6.5 Wheel Rims**

Wheel rims for the tricycle shall be size 24” for front and 26” for rear wheels conforming to IS 624 : 2003 / AIS-073 / IS 16192.

They shall be free from pitting or uneven plating. Spoke holes shall be properly punched or drilled. The spokes diameter shall be of 2.6 mm (12 G) as per IS 630 : 2005. There shall be 36 spokes in the front and rear wheels. When assembled, the spokes shall be cross without touching each other. A canvass tape of 12 mm wide conforming to IS 7298 : 1973 shall be wrapped around the rim, over riveting of spokes, to protect the tube being damaged by heads of spokes.

**6.6 Mudguards**

Mudguards shall be made from mild steel sheets, properly formed ‘open type’ with beaded edges. The front mudguards shall be provided with a steel stay made from minimum 4.0 mm diameter wire. It shall extend 150 mm beyond the forks whereas the rear mudguard shall extend 75 mm below the wheel stay on each side. A clearance of not less than 25 mm shall be provided between mudguard and the tyres and a clearance of minimum 10 mm between the wheel and fork shall be given. The mudguards shall be free from dents and other defects.

**6.7 Brakes**

Suitable type of brake, shall be fitted in the rear and front wheel, which shall be capable of applying by pressing the brake lever.

**6.8 Front Wheel Hub**

Front wheel hub assembly shall be standard unit.

**6.9 Rear Wheel Hub**

6.9.1 Right side rear wheel fitted with hub drive d.c. motor. This shall be optional if required hub drive d.c. motor may be fitted with left side rear wheel also. However, in case of detachable type of tricycle motor may be part of wheelchair itself or may be part of front hub as the case may be.

6.9.2 Left side rear wheel hub assembly shall be standard unit.

6.9.3 Tool box.

6.10 (Reserved).

**6.11 Armrest**

The armrest at its two sides shall be properly built so as to provide maximum comfort to the person driving the tricycle. The armrests shall be provided with adequate foam rubber padding all over on top.

6.12 **Lubrication**

All moving parts of the equipment normally requiring lubrication shall be provided with means for such lubrication.

6.13 Suitable means shall be provided the tricycle for keeping the crutches or walking stick securely and conveniently.

6.14 **Accessories**

The following items shall be furnished as accessories:

- a) Horn or bell;
- b) Front or head light;
- c) Right-left indicator at the rear;
- d) Red reflector on each mudguard at the rear;
- e) Set of tools (optional);
- f) Rearview mirror (optional); and
- g) Bicycle frame lock (optional).

6.15 **Servicing and Adjustment**

Prior to the delivery of the tricycle, the supplier shall service and adjust each tricycle for operational use, including at least the following:

- a) Adjustment of braking system;
- b) Alignment of wheels;
- c) Inflation of tyres and complete lubrication of operating mechanisms; and
- d) Handicapped sign to be prominently displayed at the front and the back.

6.16 **Requirements for Joining and separation arrangements**

6.16.1 The front part containing battery and hub shall be combined with manual wheelchair in such a way that,

6.16.1.1 a rigid frame / Chassis of front part shall be joined with the rigid frame / Chassis of a non-self-propelled rear module unit to form a unified rigid frame / chassis of and there will not be any relative movement between these two frames post-unification and at any point of time it shall not disengage unless otherwise intended;

6.16.1.2 Rear Wheel or any stand or support of front part, if present, in the front part must be retracted and locked above the ground during usage as combination.

- 6.16.1.3 Front part cannot be separated from the combined tricycle until rear wheel or any stand or support of front part, if present, is descended to the ground;
- 6.16.1.4 Tricycle combination cannot be propelled until rear wheel, or any stand or support of front part, if present, is retracted and locked above the ground; and
- 6.16.1.5 There should be foolproof locking so that at no point of time the rear wheel (dummy wheel) of front part shall not come down while using as Tricycle combination.
- 6.16.2 Front part combination with electric wheelchair is not required, however when the Front part is to be combined with electric wheelchair, drive of electric wheelchair needs to be disabled by suitable means OR the front part has a free wheel drive.

## **7.0 FINISH**

- 7.1 The frame of the tricycle and mudguards, prior to assembly, shall be thoroughly cleaned by suitable means to remove rust, scale and oily substances.

These shall be then chemically rust proofed and stove enamelled, spray painted or otherwise finished to give a glossy finish. The colour of the finish shall be as agreed to between the purchaser and the supplier.

- 7.2 All the metallic parts other than those mentioned in 6.1 of Part C of this standard shall have a smooth finish and shall be plated chromium over nickel in accordance with service grade No. 3 of IS 1068 : 1993 or shall be plated zinc in accordance with grade 1 of IS 1573: 1986.

## **8.0 TESTS**

### **8.1 Road Test**

Each tricycle shall be road tested by riding with a rider of  $70 \pm 5$  kg weight for a minimum distance of 25 km at speed of 10 to 25 km/h. Travel shall include, but not be limited to, level unimproved roads for testing. All the components as well as the tricycle shall be intact and no part shall be loosened on completion of the test.

### **8.2 Maneuverability**

The tricycle shall be operated at moderate speed and shall turn and steer without difficulty of operation, structural or component failure.

### **8.3 Static Load Test**

The tricycle selected for static load test shall be loaded as follows:

- a) Place 20 kg weight at steering handle end, 100 kg at the foot rest and 100 kg at the seat. The tricycle shall be subjected to this 220 kg load for not less than 15 min.
- b) There shall be no damage after the test.

**8.4 Brake Test**

The tricycle selected shall be tested for stopping ability while traveling down on 8 percent dry hard surface gradient at 15 km/h and it shall stop within a distance of 10 m. It shall be capable of braking to full stop from a speed of 15 km/h within 8 m on a dry hard surface level road, free from loose dirt and gravel.

**8.5 Test for Finish**

A solid steel ball of 13 mm diameter shall be dropped from a height of 1.5 m on any painted surface of the tricycle. The paint at the place where the steel ball strikes shall stand the impact without showing any sign of tear or peeling off.

**8.6 Max. speed test**

To confirm max. speed of 25 km/h, max. speed test shall be conducted.

**9.0 MARKING**

9.1 The tricycle shall be marked by putting a label or otherwise with the following:

- a) Manufacturer's name, initials or recognized trademark;
- b) Batch No. and date of manufacture; and
- c) Any special information regarding design or intended use.

**ANNEXURE C-1**  
(See *Clause 5.2* of Part C)

**Relevant Indian Standards on Bicycle Components**

IS 532 : 2006	Bicycle tube valves and valve-tubing (third revision)
IS 624 : 2003	Bicycle rims (fourth revision)
IS 629 : 2013	Bicycle - Hub assemblies (third revision)
IS 960 : 2005	Bicycle rim tapes and buckles (second revision)
IS 1131 : 2006	Bicycle bottom bracket axle (third revision)
IS 1132 : 2009	Bicycle - Bottom bracket adjustable ball cup (PH type) (third revision)
IS 1281 : 2014	Bicycle - Cranks and chain wheels (third revision)
IS 1282 : 2018	Bicycle cotter pins, washers and nuts - Specification (second revision)
IS 1283 : 1995	Bicycle - Free-wheels (second revision)
IS 2061 : 1995	Bicycle - Front forks (first revision)
IS 2973 : 2017	Bicycle steering head assembly - Specification (PH type) (second revision)

## PART D

### VEHICLE ADAPTATION LEGAL PROVISIONS MADE BY THE CENTRAL GOVERNMENT OF INDIA RECENTLY, FACILITIES IN INDIA AND GOOD ENGINEERING PRACTICES

- 1.0 Information on recent notifications issued by the Central Government for Adapted Vehicles**
- 1.1 MORTH letter No. RT-11036/06/2019 dated the February, 2019 (signed on 28<sup>th</sup> Feb. 2019) regarding Alterations in Motor Vehicles which allows deletion of seats, lateral/side facing seat fitment and conversion from soft top to hard top and vice versa for L5M. In case of deletion of seats as specified in clause 2.4 of Annexure B-1, no reduction in State / Centre Tax.
- 1.2 Motor Vehicle (Amendment) Act 2019 No. 32 of 2019 dated 9<sup>th</sup> August 2019 issued by Ministry of Law and Justice – It has definition of Adapted Vehicle under Section 2 of MVA and provisions on allowable changes under Section 52 of MVA.
- 1.3 MORTH notification GSR 240 (E) dated 31<sup>st</sup> March 2021, regarding definitions of L1 and L2 Two wheelers, alterations in vehicle, provisions for adapted vehicles, etc.
- 1.4 GSR 173 (E) dated 11<sup>th</sup> March 2021, regarding vehicle recall and testing of adapted vehicle, etc.
- 1.5 MoHI&PE order F. No. 12(42)/2015-AEI dated 24<sup>th</sup> October 2019 regarding various criteria for GST exemption for Adapted Vehicle (Vehicles length shall not exceed 4.0 m, gasoline engine capacity  $\leq$  1200 CC; diesel engine capacity  $\leq$  1500 CC).
- 1.6 MORTH notification GSR 401 (E) dated 24<sup>th</sup>, June 2020, regarding issuance of driving license to person with partial color blindness.
- 1.7 GSR 661 (E) dated 22<sup>nd</sup> October 2020 for modifications in Form 20 (Application for Registration of Vehicle) modifications related to addition of Ownership type e.g. Autonomous body; Divyangjan (availing GST concession / without availing GST concession); multiple owner, etc.
- 1.8 MORTH letter No. RT- 11021/40/2014-MVL dated 14<sup>th</sup> June 2016 adapted vehicle driving licence linking with type of disability.
- 2.0 List of approved retro-fitment kit manufacturers or authorized workshops for vehicle adaptations may be uploaded on test agency website or may be made available on request from Person with Disability, as deemed fit.**
- 3.0 Panel's recommendations**
- 3.1 As per present CMVR provisions for adapted vehicle, driving licence has



vehicle registration number endorsed on it, which restricts him/her from driving other adapted vehicle suitable for his/her type of disability. Driving licence shall be issued for type of disability of the person, so that person with particular type of disability can drive other adapted vehicles suitable for the type of disability.

3.2 Adapted vehicle shall be allowed to be driven by person without disability as well. This is required in following cases as example:

1. In a family one person is Person with disability however other member(s) is/are without disability, the family shall not be compelled to purchase extra vehicle.
2. In case of repairing, servicing of Adapted Vehicle, it can be driven by normal person (person without disability).

3.3 Adapted vehicle suitable for multiple limb disability shall be registered mentioning its suitability for those type of disabilities. This is required in following case as example but not limited to:

- e. g. In a family more than one person can be Person with disability however other member(s) is/are with different type of limb disability, however with introduction of flexible system enabling suitability of adapted vehicle to be driven by two or more types of disabilities is possible. This will safeguard the family from undue burden to purchase another vehicle at their wish.

**4.0 Information and procedure on getting physically disabled certificate is available on following website : [www.swaylambancard.gov.in](http://www.swaylambancard.gov.in)**

**5.0 Good engineering practices followed while vehicle adaptation**

5.1 Good engineering practices followed while vehicle adaptation as per Part A.

- Nyloc nuts to be used as retainers for locking all bolts.
- Standard thread size of nut and bolts to be used, so that when replacement is required, they are easily available.
- Use of high tensile nut / bolts for fittings that have load bearing.
- Metal Material thickness to be maintained and should not be thinner than the OE vehicle metal thickness.
- Any wiring carried out to be well insulated and secured with shrink tubing to ensure that contacts are securely fitted and fitted with 4 point / 5 point connectors.

- Any additional wiring for adapted fittings to be supported with a fuse
- Components used in the adaptations should be as standard as possible so that availability is easy.
- Wheelchair restraints wherever required to be used should be secured to proper strong points.
- Any cables used should be easily available for replacement. DIY videos should be made available on YouTube unless expertise is required.

## ANNEXURE D-1

## Standard Operating Procedure for adaptations as per part A

1. *Person with disability* approaches the Regional Transport Authority for driving license.
2. They direct him/her to the Civil Surgeon and hand over a 'Referral Letter'.
3. The Civil Surgeon or AIIPMR (All India Institute of Physical Medicine & Rehabilitation) examines the *Person with disability* and issues a Driving Fitness Certificate, in which modification(s) the *Person with disability* would require are suggested, so that the person can drive with able limbs. Driving fitness certificate also states that the person is fit to drive an Automatic transmission / manual transmission fitted with hand controls (depending on the disability.). Vehicle shall have registration in the name of *Person with disability*.
4. B.T.I. form is to be filled by the *Person with disability* stating the type of modifications / hand controls required to be done in the vehicle. The form is to be signed by the owner and to be approved by the RTO – taking permission for fitment of hand controls.
5. Vehicle to be modified by authorized workshop and relevant documents to be submitted by the RTO approved / authorized workshop.
6. Adapted Vehicle (AV) is to be presented (with a modification certificate from the modifier) for inspection at RTO to verify fittings are as per recommendations and requirements of the *Person with disability* and gets it registered as an “Adapted Vehicle”. Endorsement of the fittings will be done in the registration book by the RTO
7. *Person with disability* can now apply for a learner’s license. After one month he / she can give a driving test for a permanent license.

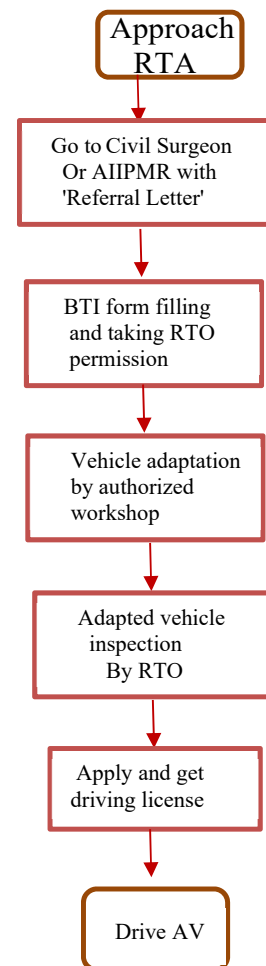

**Note :** These steps in Annexure D-1 are for vehicle adaptation from retro-fitter / authorized workshop.

**ANNEXURE 1**  
(See introduction)  
**COMPOSITION OF AISC PANEL ON**  
**ADAPTED VEHICLES\***

<b>Convener</b>	<b>ORGANISATION</b>
Mr. M. Sreenivasulu	The Automotive Research Association of India
<b>Members</b>	<b>Representing</b>
Mr. Vishwas Khedekar	The Automotive Research Association of India
Mr. V. P. Rawal	The Automotive Research Association of India
Mr. Gangaram Auti	The Automotive Research Association of India
Mr. Sanjay V. Muthekar	The Automotive Research Association of India
Ms. Shubhangi Dalvi	Central Institute of Road Transport
Mr. Mohammed Suhail	Global Automotive Research Centre
Mr. S. Perumal	Global Automotive Research Centre
Mr. Hariharan R	Global Automotive Research Centre
Mr. V. M. Dhanasekar	Global Automotive Research Centre
Ms. Vijayanta Ahuja	International Centre for Automotive Technology
Mr. Tarun Sharma	International Centre for Automotive Technology
Mr. Devendra	Indian Institute of Petroleum
Mr. Wittison Kamei	Indian Institute of Petroleum
Mr. Robindro Lairenlakpam	Indian Institute of Petroleum
Dr. Anita Gupta	All India Institute of Physical Medicines and Rehabilitation (AIIMPR)
Mr. J. V. Shah	Rtd. - Gujarat Road Safety Authority
Mr. S. Ravishankar	In personal capacity
Mr. Arvind Kumbhar	SIAM (Bajaj Auto Ltd.)
Mr. Adish Aggarwal	SIAM (Bajaj Auto Ltd.)
Mr. Harjeet Singh	SIAM (Hero Moto. Corp. Ltd.)
Mr. Piyush Chowdhry	SIAM (Hero Moto. Corp. Ltd.)
Mr. Feroz Khan	SIAM (Hero Moto. Corp. Ltd.)
Mr. Danish Gazali	SIAM (Hero Moto. Corp. Ltd.)
Mr. Navneet Kaushik	SIAM (Honda Motorcycle & Scooter India Pvt. Ltd.)
Mr. Karan Rajput	SIAM (Honda Motorcycle & Scooter India Pvt. Ltd.)
Mr. Vipin Sharma	SIAM (Honda Motorcycle & Scooter India Pvt. Ltd.)
Mr. Animesh Kumar	SIAM (Suzuki Motorcycle Ind. Pvt. Ltd.)
Mr. M. S. Anandkumar	SIAM (TVS Motor Company Ltd.)
Mr. S. Gururajan	SIAM (TVS Motor Company Ltd.)
Mr. T. Viswanathan	M. G. Motors
Mr. Yuvaraja Ponraj	Autotricks

Mr. Rahul Singh Rajput	SIAM (India Yamaha Motor Pvt. Ltd.)
Mr. Pawan Kumar	SIAM (India Yamaha Motor Pvt. Ltd.)
Mr. Abhay Kumar	SIAM (Bajaj Auto Ltd.)
Mr. D. K. Patwardhan	SIAM (Ather Energy)
Mr. Noel Alexander Peters	Denso International India Pvt. Ltd.
Mr. Jignesh Shah	Freedom wheels
Mr. Avinash Gupta	Silverline Auto
Mr. Sakthivel	Yali Mobility
Mr. Uday Harite	ACMA
Dr. Ferdinand Rodricks	Ferro Equip.
Mr. Samir Kakkad	Saika Mobility Hub, Ahmedabad
Mr. Hiren Patel	Saika Mobility Hub, Ahmedabad
Mr. Ashish	Neo Motion
Mr. Siddarth	Neo Motion
Mr. Swostik	Neo Motion

\* At the time of approval of this Automotive Industry Standard (AIS)

**ANNEXURE 2**  
(See Introduction)

**COMMITTEE COMPOSITION \***  
**Automotive Industry Standards Committee**

<b>Chairperson</b>	
Dr. Reji Mathai	Director, The Automotive Research Association of India
<b>Members</b>	<b>Representing</b>
Representative from	Ministry of Road Transport and Highways
Representative from	Ministry of Heavy Industries
Representative from	Office of the Development Commissioner, MSME, Ministry of Micro, Small and Medium Enterprises
Shri Shrikant R. Marathe	Former Chairman, AISC
Head TED	Bureau of Indian Standards
Director	Central Institute of Road Transport
Director	Global Automotive Research Centre
Director	International Centre for Automotive Technology
Director	Indian Institute of Petroleum
Director	Vehicles Research and Development Establishment
Director	Indian Rubber Manufacturers Research Association
Representatives from	Society of Indian Automobile Manufacturers
Representative from	Tractor and Mechanization Association
Representative from	Automotive Components Manufacturers Association of India
Representative from	Indian Construction Equipment Manufactures' Association (ICEMA)
<b>Member Secretary</b>	
Shri Vikram Tandon	The Automotive Research Association of India

\* At the time of approval of this Automotive Industry Standard (AIS)