

AUTOMOTIVE INDUSTRY STANDARD

**Installation Requirements of Lighting and
Light - Signalling Devices for Motor
Vehicle having more than Three Wheels
including Quadricycles, Trailer and Semi-
Trailer excluding Agricultural Tractors**

(Revision 2)

PRINTED BY
THE AUTOMOTIVE RESEARCH ASSOCIATION OF INDIA
P.B. NO. 832, PUNE 411 004

ON BEHALF OF
AUTOMOTIVE INDUSTRY STANDARDS COMMITTEE

UNDER
CENTRAL MOTOR VEHICLE RULES – TECHNICAL STANDING COMMITTEE

SET-UP BY
MINISTRY OF ROAD TRANSPORT & HIGHWAYS
(DEPARTMENT OF ROAD TRANSPORT & HIGHWAYS)
GOVERNMENT OF INDIA

February 2019

Status chart of the Standard to be used by the purchaser for updating the record

Sr. No.	Corrigenda	Amendment	Revision	Date	Remark	Misc.

General Remarks:

INTRODUCTION

The Government of India felt the need for a permanent agency to expedite the publication of standards and development of test facilities in parallel when the work on the preparation of the standards is going on, as the development of improved safety critical parts can be undertaken only after the publication of the standard and commissioning of test facilities. To this end, the Ministry of Surface Transport (MOST) has constituted a permanent Automotive Industry Standard Committee (AISC) vide order No.RT-11028/11/97-MVL dated September 15, 1997. The standards prepared by AISC will be approved by the permanent CMVR Technical Standing Committee (CTSC). After approval, the Automotive Research Association of India, (ARAI), Pune, being the Secretariat of the AIS Committee, has published this standard. For better dissemination of this information ARAI may publish this document on their website.

Installation of lighting and light-signaling devices for motor vehicle having more than three wheels, trailer and semi-trailer is a safety requirement. This standard prescribes the requirements of such installation and is in force vide notification S.O. 1365(E) dated 13th December 2004.

With a continuous change in European Regulation to cater for new technologies, and enhanced safety requirements due to increased road speed, it was felt necessary to upgrade the standard to European level. In addition to European Standard, additional conspicuity marking requirements covered by CMV Rule 104 and installation requirements for rear marking tape are included to cover all conspicuity requirements within one standard. Installation guidelines for Installation of Rear Marking Plate on Heavy and Long vehicles are moved from AIS 089: 2005 into this revised standard.

While aligning the revision of this standard to ECE R 48 (05 series Supplement 09), upgradation in various new requirements / provisions are incorporated in this Revision. Summary of which is given below:

- Definitions of Lighting function, Light signaling function, LED module, Variable intensity control, principal passing beam, conspicuity marking, lighting unit, interdependent lamp system, Rear end collision Alert signal, are newly added.
- Introduction of LED related requirements, automatic levelling device for the dipped-beam headlamps or LED light source having an objective luminous flux which exceeds 2,000 lumens.
- Optional fitment of new types of lamps, Adaptive Front Lighting System (AFS), Emergency Stop Signal, Exterior Courtesy lamp, Rear End Collision Alert Signal (RECAS), Maneuvering lamp are introduced to enhance vehicle performance. Provision of these new types of lamps increases further safety to the user of both vehicle and Road.

While preparing this standard considerable assistance has been derived from following UN regulation.

UN R 48 Revision 11 – Addendum 47 (Supplement 9 to the 05 series of amendments) Date of entry into force 8 October 2016	Uniform provisions concerning the approval of vehicles with regard to the installation of lighting and light-signaling devices
--	--

While preparing this standard attempts have been made to align with the above UN regulation. However, certain changes were necessary in the Indian context.

The AISC panel and the Automotive Industry Standards Committee (AISC) responsible for preparation of this standard are given in Annex L and Annex M respectively.

Paragraph Nos.	Contents	Page No.
1.0	Scope	1/117
2.0	Definitions	1/117
3.0 & 4.0	Reserved paragraph	12/117
5.0	General Requirements	12/117
6.0	Individual Specifications	23/117
7.0	Technical Specifications to be Submitted	79/117
8.0	Criteria for Extension of Approval	81/117
9.0	Conformity of Production Requirements	81/117
10.0	Transitional Provisions	81/117
11.0	Amendments to ECE Regulations after the level described	82/117
ANNEXES		
Annex A	Indication of the Stated Initial Adjustment Referred to in paragraph 6.2.6.1.1 of this standard	95/117
Annex B	States of Loading to be taken into consideration in determining Variations in the Vertical Orientation of the Dipped-beam Headlamps	96/117
Annex C	Measurement of the variation of Dipped- beam inclination as a Function of Load (Ref. paragraph 6.2.6.3.2)	98/117
Annex D	The Controls for the Headlamp - Leveling Devices	103/117
Annex E	Examples of Light Source Options	105/117
Annex F	Visibility of conspicuity markings to the rear, front and side of a vehicle	106/117
Annex G	Test drive	107/117
Annex H	Automatic switching conditions dipped-beam headlamps	110/117
Annex I	Observing area towards the apparent surface of maneuvering	111/117
Annex J	Gonio (photo) meter system used for the photometric measurements	112/117
Annex K	Guidelines for Installation of Rear Marking plates on Heavy and Long Vehicles	113/117
Annex L	Composition of AISC Panel	115/117
Annex M	Composition of Automotive Industry Standards Committee	117/117

**Installation Requirements of Lighting and Light-Signaling Devices
for Motor Vehicle having more than Three Wheels, Trailer and
Semi -Trailer excluding Agricultural Tractor**

1.0 SCOPE

This standard applies to the approval of power-driven vehicles intended for use on the road, with or without bodywork, with not less than four wheels and a maximum design speed exceeding 25 km/h, and of their trailers, with the exception of vehicles, which run on rails, agricultural or forestry tractors and machinery, and public works vehicles.

Note: “This standard does not apply to Special Purpose Vehicle except Motor Caravans.”

1.1 References

1.1.1 The following standards are necessary adjuncts to this standard:

IS: 9211-2003 "Terms and Definitions of Weights of Road Vehicles other than 2 and 3 wheelers".

1.1.2 AIS-053 "Automotive Vehicles - Types – Terminology”

1.1.3 AIS-012:2004 "Performance Requirements of Lighting and Light Signaling Devices for Motor Vehicle having more than Three Wheels, Trailer and Semi-Trailer

1.1.4 IS: 9435: 2004 "Terms and Definitions Relating to Dimensions of Road Vehicles"

2.0 DEFINITIONS

For the purpose of this Standard the following definitions shall apply

2.1 **"Approval of a vehicle"** means the approval of a vehicle type with regard to the number and mode of installation of the lighting and light-signaling devices.

2.2 **"Vehicle type"** with regard to the installation of lighting and light-signaling devices means vehicles, which do not differ in the essential respects mentioned in paragraphs 2.2.1. to 2.2.4.

The following are likewise considered not to be "vehicles of a different type":

Vehicles which differ within the meaning of paragraphs 2.2.1. to 2.2.4., but not in such a way as to entail a change in the kind, number, positioning and geometric visibility of the lamps and the inclination of the dipped-beam prescribed for the vehicle type in question, and vehicles on which optional lamps are fitted or absent:

2.2.1. The dimension and the external shape of the vehicle;

- 2.2.2. The number and positioning of the devices;
- 2.2.3. The headlamp-levelling system;
- 2.2.4. The suspension system.
- 2.3. **"Transverse plane"** means a vertical plane perpendicular to the median longitudinal plane of the vehicle.
- 2.4 **"Unladen vehicle"** means the vehicle in kerb weight condition as specified in IS: 9211- 2003.
- 2.5 **"Laden vehicle"** means the vehicle loaded to its maximum permissible weight (GVW) as stated by the manufacturer who shall also specify the distribution of this weight between the axles.
- 2.6. **"Device"** means an element or an assembly of elements used to perform one or more functions.
 - 2.6.1. **"Lighting function"** means the light emitted by a device to illuminate the road and objects in the direction of vehicle movement.
 - 2.6.2. **"Light-signaling function"** means the light emitted or reflected by a device to give to other road users visual information on the presence, identification and/or the change of movement of the vehicle.
- 2.7. **"Lamp"** means a device designed to illuminate the road or to emit a light signal to other road users. Rear registration plate lamps and retro-reflectors are likewise to be regarded as lamps.
 - 2.7.1. **Light source**
 - 2.7.1.1. **"Light source"** means one or more elements for visible radiation, which may be assembled with one or more transparent envelopes and with a base for mechanical and electrical connection.
 - 2.7.1.1.1. **"Replaceable light source"** means a light source which is designed to be inserted in and removed from the holder of its device without tool.
 - 2.7.1.1.2. **"Non-replaceable light source"** means a light source which can only be replaced by replacement of the device to which this light source is fixed.
 - (a) In case of a light source module: a light source which can only be replaced by replacement of the light source module to which this light source is fixed;
 - (b) In case of adaptive front-lighting systems (AFS): a light source which can only be replaced by replacement of the lighting unit to which this light source is fixed.

- 2.7.1.1.3. **"Light source module"** means an optical part of a device which is specific to that device, It contains one or more non-replaceable light sources and it may optionally contain one or more holders for approved replaceable light sources.
- 2.7.1.1.4. **"Filament light source"** (filament lamp) means a light source where the element for visible radiation is one or more heated filaments producing thermal radiation.
- 2.7.1.1.5. **"Gas-discharge light source"** means a light source where the element for visible radiation is a discharge arc producing electro-luminescence / fluorescence.
- 2.7.1.1.6. **"Light-emitting diode (LED) light source"** means a light source where the element for visible radiation is one or more solid state junctions producing injection- luminescence/fluorescence.
- 2.7.1.1.7. **"LED module"** means a light source module containing as light sources only LEDs. However, it may optionally contain one or more holders for approved replaceable light sources.
- 2.7.1.2. **"Electronic light source control gear"** means one or more components between supply and light source, whether or not integrated with the light source or the applied lamp, to control voltage and/ or electrical current of the light source.
- 2.7.1.2.1. **"Ballast"** means an electronic light source control gear between supply and light source, whether or not integrated with the light source or applied lamp, to stabilize the electrical current of a gas-discharge light source.
- 2.7.1.2.2. **"Ignitor"** means an electronic light source control gear to start the arc of a gas-discharge light source.
- 2.7.1.3. **"Variable intensity control"** means the device which automatically controls rear light signaling devices producing variable luminous intensities to assure the unvarying perception of their signals. The variable intensity control is part of the lamp, or part of the vehicle, or split between the said lamp and the vehicle.
- 2.7.2. **"Equivalent lamps"** means lamps having the same function. These may have different characteristics from those installed on the vehicle when it is approved on condition that they satisfy the requirements of this Standard.
- 2.7.3. **"Independent lamps"** means devices having separate apparent surfaces in the direction of the reference axis, separate light sources and separate lamp bodies.
- 2.7.4. **"Grouped lamps"** means devices having separate apparent surfaces in the direction of the reference axis and separate light sources, but a common lamp body.

- 2.7.5. **"Combined lamps"** means devices having separate apparent surfaces in the direction of the reference axis, but a common light source and a common lamp body.
- 2.7.6. **"Reciprocally incorporated lamps"** means devices having separate light sources or a single light source operating under different conditions (for example, optical, mechanical, electrical differences), totally or partially common apparent surfaces in the direction of the reference axis and a common lamp body.
- 2.7.7. **"Single-function lamp"** means a device part of a device which performs a single lighting or light-signaling function.
- 2.7.8. **"Concealable lamp"** means a lamp capable of being partly or completely hidden when not in use. This result may be achieved by means of a movable cover, by displacement of the lamp or by any other suitable means. The term "*retractable*" is used more particularly to describe a concealable lamp the displacement of which enables it to be inserted within the bodywork.
- 2.7.9. **"Driving-beam (main-beam) headlamp"** means the lamp used to illuminate the road over a long distance ahead of the vehicle.
- 2.7.10. **"Passing-beam (dipped-beam) headlamp"** means the lamp used to illuminate the road ahead of the vehicle without causing undue dazzle or discomfort to oncoming drivers and other road-users.
- 2.7.10.1. **"Principal passing-beam (principal dipped-beam)"** means the dipped-beam produced without the contribution of infrared (IR) emitter and/or additional light sources for bend lighting.
- 2.7.11. **"Direction-indicator lamp"** means the lamp used to indicate to other road-users that the driver intends to change direction to the right or to the left. A direction-indicator lamp or lamps may also be used according to the provisions of AIS-076.
- 2.7.12. **"Stop lamp"** means a lamp used to indicate to other road users to the rear of the vehicle that the longitudinal movement of the vehicle is intentionally retarded.
- 2.7.13. **"Rear-registration plate (mark) illuminating device"** means the device used to illuminate the space reserved for the rear registration plate; such a device may consist of several optical components.
- 2.7.14. **"Front position lamp"** means the lamp used to indicate the presence and the width of the vehicle when viewed from the front.
- 2.7.15. **"Rear position lamp"** means the lamp used to indicate the presence and width of the vehicle when viewed from the rear.
- 2.7.16. **"Retro-reflector"** means a device used to indicate the presence of a vehicle by the reflection of light emanating from a light source not connected to the vehicle, the observer being situated near the source.

- 2.7.16.1. Retro-reflecting number plates;
- 2.7.16.2. The retro-reflecting signals;
- 2.7.16.3. Other retro-reflective markings plates and signals which shall be used to comply with national requirements for use as regards certain categories of vehicles or certain methods of operation;
- 2.7.16.4. Retro-Reflecting materials approved as Class D or E or F according to standard AIS-057 and used for other purposes in compliance with national requirements.
- 2.7.17. "**Conspicuity marking**" means a device intended to increase the conspicuity of a vehicle, when viewed from the side or rear (or in the case of trailers, additionally from the front), by the reflection of light emanating from a light source not connected to the vehicle, the observer being situated near the source.
 - 2.7.17.1. "**Contour marking**" means a conspicuity marking intended to indicate the horizontal and vertical dimensions (length, width and height) of a vehicle.
 - 2.7.17.1.1. "**Full contour marking**" means a contour marking that indicates the outline of the vehicle by a continuous line.
 - 2.7.17.1.2. "**Partial contour marking**" means a contour marking that indicates the horizontal dimension of the vehicle by a continuous line, and the vertical dimension by marking the upper corners.
 - 2.7.17.2. "**Line marking**" means a conspicuity marking intended to indicate the horizontal dimensions (length and width) of a vehicle by a continuous line.
- 2.7.18. "**Hazard warning signal**" means the simultaneous operation of all the direction indicator lamps of a vehicle to draw attention to the fact that the vehicle temporarily constitutes a special danger to other road users.
- 2.7.19. "**Front fog lamp**" means a lamp in case of fog, snowfall, rainstorms or dust clouds to improve the illumination of the road.
- 2.7.20. "**Rear fog lamp**" means a lamp used to make the vehicle more easily visible from the rear in dense fog, snowfall, rainstorms or dust clouds.
- 2.7.21. "**Reversing lamp**" means the lamp used to illuminate the road to the rear of the vehicle and to warn other road-users that the vehicle is reversing or about to reverse.
- 2.7.22. "**Parking lamp**" means a lamp which is used to draw attention to the presence of a stationary vehicle in a built-up area. In such circumstances it replaces the front and rear position lamps.

- 2.7.23. **"End-outline marker lamp"** means the lamp fitted near to the extreme outer edge and as close as possible to the top of the vehicle and intended to indicate clearly the vehicle's overall width. This lamp is intended, for certain vehicles and trailers, to complement the vehicle's front and rear position lamps by drawing particular attention to its bulk.
- 2.7.24. **"Side marker lamp"** means a lamp used to indicate the presence of the vehicle when viewed from the side.
- 2.7.25. **"Daytime running lamp"** means a lamp facing in a forward direction used to make the vehicle more easily visible when driving during daytime.
- 2.7.26. **"Cornering lamp"** means a lamp used to provide supplementary illumination of that part of the road which is located near the forward corner of the vehicle at the side towards which the vehicle is going to turn.
- 2.7.27. **"Objective luminous flux" means:**
- (a) In the case of a light source:

The value of the objective luminous flux, not including any tolerances, as indicated in the relevant data sheet of the applicable light source standard according to which the light source is approved;
 - (b) In the case of an LED module:

The value of the objective luminous flux as indicated in the technical specification submitted with the LED module for approval of the lamp of which the LED module is a part;
- 2.7.28. **"Adaptive front lighting system"** (or "AFS") means a lighting device type-approved according to standard AIS 127, providing beams with differing characteristics for automatic adaptation to varying conditions of use of the dipped-beam (passing-beam) and, if it applies, the main-beam (driving-beam).
- 2.7.28.1. **"Lighting unit"** means a light-emitting component designed to provide or contribute to one or more front lighting function(s) provided by the AFS.
- 2.7.28.2. **"Installation unit"** means an indivisible housing (lamp body) which contains one or more lighting unit(s).
- 2.7.28.3. **"Lighting mode" or "mode"** means a state of a front lighting function provided by the AFS, as specified by the manufacturer and intended for adaptation to specific vehicle and ambient conditions.
- 2.7.28.4. **"System control"** means that part(s) of the AFS receiving the AFS control signals from the vehicle and controlling the operation of the lighting units automatically.

- 2.7.28.5. **"AFS control signal"** (V, E, W, T) means the input to the AFS in accordance with the paragraph 6.22.7.4. of this standard.
- 2.7.28.6. **"Neutral state"** means the state of the AFS when a defined mode of the class C passing- beam ("basic passing-beam") or of the main beam in the maximum condition of activation, if any, is produced, and no AFS control signal applies.
- 2.7.28.7. **"Adaptive main-beam"** means a main-beam of the AFS that adapts its beam pattern to the presence of oncoming and preceding vehicles in order to improve the long-range visibility for the driver without causing discomfort, distraction or glare to other road users.
- 2.7.29. **"Exterior courtesy lamp"** means a lamp used to provide supplementary illumination to assist the entry and exit of the vehicle driver and passenger or in loading operations.
- 2.7.30. **"Interdependent lamp system"** means an assembly of two or three interdependent lamps providing the same function.
- 2.7.30.1. **"Interdependent lamp" marked "Y"** means a device operating as part of an interdependent lamp system. Interdependent lamps operate together when activated, have separate apparent surfaces in the direction of the reference axis and separate lamp bodies, and may have separate light source(s).
- 2.7.31. **"Manoeuvring lamp"** means a lamp used to provide supplementary illumination to the side of the vehicle to assist during slow manoeuvres.
- 2.7.32. **"Lamps marked "D"** means independent lamps, approved as separate devices in such a way that they are allowed to be used either independently or in an assembly of two lamps to be considered as a "single lamp".
- 2.8. **"Light emitting surface" of a "lighting device"**, "light-signaling device" or a retro- reflector means the surface as declared in the request for approval by the manufacturer of the device on the drawing, (see clause 11.3. Fig 1 and Examples A to E).

This shall be declared according to one of the following conditions:

- (a) In the case where the outer lens is textured, the declared light emitting surface shall be all or part of the exterior surface of the outer lens;
- (b) In the case where the outer lens is non-textured the outer lens may be disregarded and the light emitting surface shall be as declared on the drawing, see (clause 11.3 Ref. Fig 1 and Examples A to E).

- 2.8.1. **"Textured outer lens"** or **"Textured outer lens area"** means all or part of an outer lens, designed to modify or influence the propagation of light from the light source(s), such that the light rays are significantly diverted from their original direction.
- 2.9. **"Illuminating surface"** (Ref. Fig 1 and Examples A to E)
- 2.9.1. **"Illuminating surface of a lighting device"** (paragraphs 2.7.9., 2.7.10., 2.7.19., 2.7.21. and 2.7.26.) means the orthogonal projection of the full aperture of the reflector, or in the case of headlamps with an ellipsoidal reflector of the "projection lens", on a transverse plane. If the lighting device has no reflector, the definition of paragraph 2.9.2. Shall be applied. If the light emitting surface of the lamp extends over part only of the full aperture of the reflector, then the projection of that part only is taken into account.

In the case of a dipped-beam headlamp, the illuminating surface is limited by the apparent trace of the cut-off on to the lens. If the reflector and lens are adjustable relative to one another, the mean adjustment should be used.

In the case of AFS being installed: where a lighting function is produced by two or more simultaneously operated lighting units on a given side of the vehicle, the individual illuminating surfaces, taken together, constitute the illuminating surface to be considered (for example, in the figure of paragraph 6.22.4. below, the individual illuminating surfaces of the lighting units 8, 9 and 11, regarded together and taking into account their respective location, constitute the illuminating surface to be considered for the right hand side of the vehicle).

- 2.9.2. **"Illuminating surface of a light-signalling device other than a retro-reflector"** (paragraphs 2.7.11. to 2.7.15., 2.7.18., 2.7.20. and 2.7.22. to 2.7.25) means the orthogonal projection of the lamp in a plane perpendicular to its axis of reference and in contact with the exterior light-emitting surface of the lamp, this projection being bounded by the edges of screens situated in this plane, each allowing only 98 per cent of the total luminous intensity of the light to persist in the direction of the axis of reference.

To determine the lower, upper and lateral limits of the illuminating surface only screens with horizontal or vertical edges shall be used to verify the distance to the extreme edges of the vehicle and the height above the ground.

For other applications of the illuminating surface, e.g. distance between two lamps or functions, the shape of the periphery of this illuminating surface shall be used. The screens shall remain parallel, but other orientations are allowed to be used.

In the case of a light-signaling device whose illuminating surface encloses either totally or partially the illuminating surface of another function or encloses a non-lighted surface, the illuminating surface may be considered to be the light emitting surface itself (clause 11.3 Parts 2, 3, 5 and 6)

- 2.9.3. **"Illuminating surface of a retro-reflector"** (paragraph 2.7.16.) means, as declared by the applicant during the component approval procedure for the retro-reflectors, the orthogonal projection of a retro-reflector in a plane perpendicular to its axis of reference and delimited by planes contiguous to the declared outermost parts of the retro-reflectors' optical system and parallel to that axis. For the purposes of determining the lower, upper and lateral edges of the device, only horizontal and vertical planes shall be considered.
- 2.10. **The "Apparent surface"** means the apparent surface for a defined direction of observation means, at the request of the manufacturer, the orthogonal projection of:
- Either the boundary of the illuminating surface projected on the exterior surface of the lens;
- Or the light-emitting surface
- Only in the case of a light-signaling device producing variable luminous intensities, its apparent surface that may be variable as specified in paragraph 2.7.1.3. shall be considered under all conditions permitted by the variable intensity control, if applicable.
- In a plane perpendicular to the direction of observation and tangential to the most exterior point of the lens. Different examples of the application of apparent surface can be found after clause 11.3 of this Standard.
- 2.11. **"Axis of reference / reference axis"** means the characteristic axis of the lamp determined by the lamp manufacturer for use as the direction of reference ($H=0^\circ$, $V=0^\circ$) for angles of field for photometric measurements and for installing the lamp on the vehicle.
- 2.12. **"Centre of reference / reference Centre"** means the intersection of the axis of reference with the exterior light-emitting surface; it is to be specified by the manufacturer of the lamp.
- 2.13. **"Angles of geometric visibility"** means the angles which determine the field of the minimum solid angle in which the apparent surface of the lamp is visible. That field of the solid angle is determined by the segments of the sphere of which the Centre coincides with the Centre of reference of the lamp and the equator is parallel with the ground. These segments are determined in relation to the axis of reference. The horizontal angles β correspond to the longitude and the vertical angles α to the latitude.

- 2.14. **"Extreme outer edge"** on either side of the vehicle, means the plane parallel to the median longitudinal plane of the vehicle and touching its lateral outer edge, disregarding the projection:
- 2.14.1. Of tyres near their point of contact with the ground, and of connections for tyre-pressure gauges;
 - 2.14.2. Of anti-skid devices mounted on the wheels;
 - 2.14.3. Of devices for indirect vision;
 - 2.14.4. Of side direction-indicator lamps, end-outline marker lamps, front and rear position lamps, parking lamps, retro-reflectors and side-marker lamps.
 - 2.14.5. Of seals affixed to the vehicle, and of devices for securing and protecting such seals.
 - 2.14.6. Of service-door lighting systems on vehicles of categories M2 and M3 as specified in paragraph 2.7.
- 2.15. **"Overall width"** means the distance between the two vertical planes of extreme outer edges defined in paragraph 2.14. above.
- 2.16. **"Single and multiple lamps"**
- 2.16.1. **"A single lamp" means:**
 - (a) A device or part of a device having one lighting or light-signaling function, one or more light source(s) and one apparent surface in the direction of the reference axis, which may be a continuous surface or composed of two or more distinct parts; or
 - (b) Any assembly of two lamps marked "D", whether identical or not, having the same function; or
 - (c) Any assembly two independent retro-reflectors, whether identical or not, that have been approved separately; or
 - (d) Any interdependent lamp system composed of two or three interdependent lamps marked "Y" approved together and providing the same function.
 - 2.16.2. "Two lamps" or "an even number of lamps" in the shape of a band or strip, means two lamps with a single light-emitting surface, providing such a band or strip is placed symmetrically in relation to the median longitudinal plane of the vehicle.
- 2.17. **"Distance between two lamps"** facing the same direction means the shortest distance between the two apparent surfaces in the direction of the reference axis. Where the distance between the lamps clearly meets the requirements of the standard, the exact edges of apparent surfaces need not be determined.

- 2.18. **"Operating tell-tale"** means a visual or auditory signal (or any equivalent signal) indicating that a device has been switched on and is operating correctly or not.
- 2.19. **"Closed-circuit tell-tale"** means a visual (or any equivalent signal) indicating that a device has been switched on, but not indicating whether it is operating correctly or not.
- 2.20. **"Optional lamp"** means a lamp, the installation of which is left to the discretion of the manufacturer.
- 2.21. **"Ground"** means the surface on which the vehicle stands which should be substantially horizontal.
- 2.22. **"Movable components"** of the vehicle mean those body panels or other vehicle parts the position(s) of which can be changed by tilting, rotating or sliding without the use of tools. They do not include tiltable driver cabs of trucks.
- 2.23. **"Normal position of use of a movable component"** means the position(s) of a movable component specified by the vehicle manufacturer for the normal condition of use and the park condition of the vehicle.
- 2.24. **"Normal condition of use of a vehicle"** means:
- 2.24.1. For a motor vehicle, when the vehicle is ready to move with its propulsion engine running and its movable components in the normal position(s) as defined in paragraph 2.23.;
- 2.24.2. And for a trailer, when the trailer is connected to a drawing motor vehicle in the conditions as prescribed in paragraph 2.24.1. and its movable components are in the normal position(s) as defined in paragraph 2.23.
- 2.25. **"Park condition of a vehicle"** means:
- 2.25.1 For a motor vehicle, when the vehicle is at standstill and its propulsion engine is not running and its movable components are in the normal position(s) as defined in paragraph 2.23.;
- 2.25.2. And for a trailer, when the trailer is connected to a drawing motor vehicle in the condition as described in paragraph 2.25.1. and its movable components are in the normal position(s) as defined in paragraph 2.23.
- 2.26. **"Bend lighting"** means a lighting function to provide enhanced illumination in bends.
- 2.27. **"Pair"** means the set of lamps of the same function on the left- and right-hand side of the vehicle.
- 2.27.1. **"Matched pair"** means the set of lamps of the same function on the left- and right-hand side of the vehicle, which, as a pair, complies with the photometric requirements.

- 2.28. **"Emergency stop signal"** means a signal to indicate to other road users to the rear of the vehicle that a high retardation force has been applied to the vehicle relative to the prevailing road condition.
- 2.29. **"Rear-end collision alert signal (RECAS)"** means an automatic signal given by the leading vehicle to the following vehicle. It warns that the following vehicle needs to take emergency action to avoid a collision.
- 2.30. **"Rear marking plate"** a rectangular plate with a characteristic pattern faced with retro reflective and fluorescent materials or devices.
- 2.31. **"Gonio (photo)meter system** (If not otherwise specified in a particular standard)" means a system used for the photometric measurements specified by the angular coordinates in degrees on a sphere with a vertical polar axis according to CIE publication No. 70, Vienna 1987, i.e. corresponding to a gonio (photo)meter system with a horizontal ("elevation") axis fixed to the ground and a second, moveable ("rotation") axis perpendicular to the fixed horizontal axis (see Annex 14 to this standard). Note: The above mentioned CIE publication specifies a procedure to correct the angular coordinates in the case where an alternative gonio (photo) meter system is used.
- 2.32. Sequential activation means an electrical connection where the individual light sources of a lamp are wired such that they are activated in a predetermined sequence.
- 3.0** Reserved paragraph
- 4.0** Reserved paragraph
- 5.0** **GENERAL SPECIFICATIONS**
- 5.1. Only those lighting and light signalling devices referred to in 6.0 of this standard shall be permitted to be installed on motor vehicles.
- The lighting and light-signaling devices shall be so fitted that under normal conditions of use as defined in 2.24.1. and 2.24.2. and notwithstanding any vibrations to which they may be subjected, they retain the characteristics laid down by this standard and enable the vehicle to comply with the requirements of this standard. In particular, it shall not be possible for the adjustment of the lamps to be inadvertently disturbed.
- 5.2. The illuminating lamps described in paragraphs 2.7.9., 2.7.10. and 2.7.19. shall be so installed that correct adjustment of their orientation can easily be carried out.
- 5.2.1. In the case of headlamps fitted with measures to prevent discomfort to other road-users in a country where traffic operates on the side of the road opposite to that of the country for which the headlamp was designed, such measures shall be achieved automatically or by the vehicle user with the vehicle in the park condition without the need for special tools (other than those provided with the vehicle). Detailed instructions shall be provided by the vehicle manufacturer with the vehicle.

- 5.3. For all light-signalling devices, including those mounted on the side panels, the reference axis of the lamp when fitted to the vehicle shall be parallel to the bearing plane of the vehicle on the road; in addition, it shall be perpendicular to the median longitudinal plane of the vehicle in the case of side retro-reflectors and of side-marker lamps and parallel to that plane in the case of all other signalling devices. In each direction a tolerance of $\pm 3^\circ$ shall be allowed. In addition, any specific instructions as regards fitting laid down by the manufacturer shall be complied with.
- 5.4. In the absence of specific instructions, the height and orientation of the lamps shall be verified with the vehicle unladen and placed on a flat, horizontal surface in the condition defined in paragraphs 2.24., 2.24.1. and 2.24.2. and, in the case where an AFS is installed, with the system in its neutral state.
- 5.5. In the absence of specific requirements lamps constituting a pair shall:
- 5.5.1. Be fitted to the vehicle symmetrically in relation to the median longitudinal plane (this estimate to be based on the exterior geometrical form of the lamp and not on the edge of its illuminating surface referred to in paragraph 2.9.);
- 5.5.2. Be symmetrical to one another in relation to the median longitudinal plane, this requirement is not valid with regard to the interior structure of the lamp;
- 5.5.3. Satisfy the same colorimetric requirements (component type approval value) and have substantially identical photometric characteristics. This shall not apply to a matched pair of Class F3 front fog lamps;
- 5.5.4. Have substantially identical photometric characteristics (component type approval)
- 5.6. On vehicles whose external shape is asymmetrical, the above requirements shall be satisfied so far as is possible.
- 5.7 **Grouped, combined or reciprocally incorporated or single lamps**
- 5.7.1. Lamps may be grouped, combined or reciprocally incorporated with one another provided that all requirements regarding colour, position, orientation, geometric visibility, electrical connections and other requirements, if any, for each lamp are fulfilled.
- 5.7.1.1. The photometric and colorimetric requirements of a lamp shall be fulfilled when all other functions with which this lamp is grouped, combined or reciprocally incorporated are switched OFF.
- However, when a front or rear position lamp is reciprocally incorporated with one or more other function(s) which can be activated together with them, the requirements regarding colour of each of these other functions shall be fulfilled when the reciprocally incorporated function(s) and the front or rear position lamps are switched ON.

5.7.1.2. Stop lamps and direction-indicator lamps are not permitted to be reciprocally incorporated.

5.7.1.3. Where stop lamps and direction-indicator lamps are grouped, the following conditions shall be met:

5.7.1.3.1. Any horizontal or vertical straight line passing through the projections of the apparent surfaces of these functions on a plane perpendicular to the reference axis, shall not intersect more than two borderlines separating adjacent areas of different colour;

5.7.1.3.2. Their apparent surfaces in the direction of the reference axis, based upon the areas bounded by the outline of their light emitting surfaces, do not overlap.

5.7.2. Single lamps

5.7.2.1. Single lamps as defined in paragraph 2.16.1. (a), composed of two or more distinct parts, shall be installed in such a way that:

(a) Either the total area of the projection of the distinct parts on a plane tangent to the exterior surface of the outer lens and perpendicular to the reference axis shall occupy not less than 60 per cent of the smallest quadrilateral circumscribing the said projection; or

(b) The minimum distance between the facing edges of two adjacent/tangential distinct parts shall not exceed 75 mm when measured perpendicularly to the reference axis.

This requirement shall not apply to a retro-reflector.

5.7.2.2. Single lamps as defined in paragraph 2.16.1. (b) or (c), composed of two lamps marked "D" or two independent retro reflectors, shall be installed in such a way that:

(a) either the projection of the apparent surfaces in the direction of the reference axis of the two lamps or retro reflectors occupies not less than 60 per cent of the smallest quadrilateral circumscribing the projections of the said apparent surfaces in the direction of the reference axis; or

(b) the minimum distance between the facing edges of the apparent surfaces in the direction of the reference axis of two lamps or two independent retro reflectors does not exceed 75 mm when measured perpendicularly to the reference axis.

5.7.2.3. Single lamps as defined in paragraph 2.16.1(d). shall fulfil the requirements of paragraph 5.7.2.1.

Where two or more lamps and/or two or more separate apparent surfaces are included into the same lamp body and/or have a common outer lens these shall not be considered as an interdependent lamp system.

However, a lamp in the shape of a band or strip may be part of an interdependent lamp system.

- 5.7.2.4. Two lamps or an even number of lamps in the shape of a band or strip shall be placed symmetrically in relation to the median longitudinal plane of the vehicle, extending on both sides to within at least 0.4 m of the extreme outer edge of the vehicle, and are not less than 0.8 m long; the illumination of such a surface shall be provided by not less than two light sources placed as close as possible to the ends; the light-emitting surface may be constituted by a number of juxtaposed elements on condition that these individual light-emitting surfaces, when projected on a transverse plane fulfil the requirements of paragraph 5.7.2.1.
- 5.8. The maximum height above the ground shall be measured from the highest point and the minimum height from the lowest point of the apparent surface in the direction of the reference axis.
- In the case of dipped-beam headlamp, the minimum height shall be measured from the lowest point of the effective outlet of the optical system (e.g. reflector, lens, projection lens) independent of its utilization.
- Where the (maximum and minimum) height clearly meets the requirements of the standard, the exact edges of any surface need not be determined.
- 5.8.1 The position, as regards width, shall be determined from that edge of the apparent surface in the direction of the reference axis which is the farthest from the median longitudinal plane of the vehicle when referred to the overall width, and from the inner edges of the apparent surface in the direction of the reference axis when referred to the distance between lamps.
- Where the position, as regards width, clearly meets the requirements of the standard the exact edges of any surface need not be determined.
- 5.9. In the absence of specific requirements, the photometric characteristics (e.g. intensity, colour, apparent surface, etc.) of a lamp shall not be intentionally varied during the period of activation of the lamp.
- 5.9.1. Direction-indicator lamps, the vehicle-hazard warning signal, amber side-marker lamps complying with paragraph 6.18.7. below, and the emergency stop signal shall be flashing lamps.
- 5.9.2. The photometric characteristics of any lamp may vary:
- (a) In relation to the ambient light;
 - (b) As a consequence of the activation of other lamps; or
 - (c) When the lamps is being used to provide another lighting function; Provided that any variation in the photometric characteristics is in compliance with the technical provisions for the lamp concerned.

- 5.9.3. The photometric characteristics of a direction indicator lamp of categories 1, 1a, 1b, 2a or 2b may be varied during a flash by sequential activation of light sources as specified in paragraph 5.6. of standard AIS-012
- This provision shall not apply when direction indicator lamps of categories 2a and 2b are operated as emergency stop signal according to paragraph 6.23.1. of this Standard.
- 5.10 No red light in the forward direction and no white light in the rearward direction, shall be emitted from a lamp (which could give rise to confusion), While considering this requirement, no account shall be taken of lighting devices fitted in the interior of the vehicle. In case of doubt, this requirement shall be verified as follows:
- 5.10.1. For the visibility of red light towards the front of a vehicle, with the exception of a red rearmost side-marker lamp, there shall be no direct visibility of the light emitting surface of a red lamp if viewed by an observer moving within zone 1 in a transverse plane situated 25 m in front of the vehicle (clause 11.4).
- 5.10.2. For the visibility of white light towards the rear, with the exception of reversing lamps and white side conspicuity markings fitted to the vehicle, there shall be no direct visibility of the light emitting surface of a white lamp if viewed by an observer moving within Zone 2 in a transverse plane situated 25 m behind the vehicle (clause 11.4).
- 5.10.3. In their respective planes, the zones 1 and 2 explored by the eye of the observer are bounded:
- 5.10.3.1. As regards In height, by two horizontal planes 1 m and 2.2 m respectively above the ground;
- 5.10.3.2. As regards width, by two vertical planes which, forming to the front and to the rear respectively an angle of 15° outwards from the vehicle's median longitudinal plane, pass through the point or points of contact of vertical planes parallel to the vehicle's median longitudinal plane delimiting the vehicle's overall width; if there are several points of contact, the farthest forward shall correspond to the forward plane and the rearmost to the rearward plane.
- 5.11. The electrical connections shall be such that the front and rear position lamps, end- outline marker lamps, side-marker lamps, and the rear registration plate lamp wherever fitted can only be switched ON and OFF simultaneously.
- 5.11.1. This condition does not apply:
- 5.11.1.1. When using front and rear position lamps are switched ON, as well as side-marker lamps when combined or reciprocally incorporated with said lamps, as parking lamps; or
- 5.11.1.2. When side-marker lamp flash in conjunction with direction indicators; or

- 5.11.1.3. When light signalling system operates according to 6.2.7.6.2.
- 5.11.2. To front position lamps when their function is substituted under the provisions of paragraph 5.12.1. below.
- 5.11.3. In the case of an interdependent lamp system, all light sources shall be switched ON and OFF simultaneously.
- 5.12. The electrical connections shall be such that main-beam and dipped-beam headlamps and the front fog lamps cannot be switched ON unless the lamps referred to in paragraph 5.11 above are also switched ON. This requirement shall not apply, however, to main-beam or dipped-beam headlamps when their luminous warning consist of the intermittent lighting up at short intervals of the main-beam headlamp/dipped-beam headlamps or the alternate lighting up at short intervals of the main-beam and dipped-beam headlamps.
- 5.12.1. The dipped-beam headlamps and/or the main-beam headlamps and / or the front fog lamps may substitute the function of the front position lamps, provided that:
 - 5.12.1.1. Their electrical connections are such that in case of failure of any of these lighting devices the front position lamps are automatically re-activated; and
 - 5.12.1.2. The substituting lamp/function meets, for the respective position lamp, the requirements concerning:
 - (a) The geometric visibility prescribed for the front position lamps in 6.9.5; and
 - (b) The minimum photometric values according to the angles of light distribution; and
 - 5.12.1.3. Appropriate evidence demonstrating compliance with the requirements indicated in paragraph 5.12.1.2. above is provided in the test reports of the substituting lamp.
- 5.13. Tell-tale: The function of circuit closed tell-tale may be fulfilled by operational tell- tale.
- 5.14. **Concealable lamps**
- 5.14.1. The concealment of lamps shall be prohibited, with the exception of the main-beam headlamps, the dipped-beam headlamps and the front fog lamps, which may be concealed when they are not in use.
- 5.14.2. In the event of any failure affecting the operation of the concealment device(s) the lamps shall remain in the position of use, if already in use, or shall be capable of being moved into the position of use without the aid of tools.
- 5.14.3. It shall be possible to move the lamps into the position of use and switch them ON by means of a single control, without excluding the possibility of moving them into the position of use without switching them ON. However, in the case of grouped main-beam and dipped-beam headlamps, the control referred to above is required only to activate the dipped-beam headlamps.

- 5.14.4. It shall not be possible deliberately, from the driver's seat, to stop the movement of switched-on lamps before they reach the position of use. If there is a danger of dazzling other road users by the movement of the lamps, they may light up only when they have reached their position of use.
- 5.14.5. When the concealment device has a temperature of -30 °C to +50 °C the headlamps shall be capable of reaching the position of use within three seconds of initial operation of the control.
- 5.15. **The colours of the light emitted by the lamps are the following:**

main-beam headlamp	White
dipped-beam headlamp	White
front fog lamp	White or selective yellow
reversing lamp	White
direction-indicator lamp	Amber
hazard warning signal	Amber
stop lamp	Red
emergency stop signal	Amber or Red
rear-end collision alert signal	Amber
rear registration plate lamp	White
front position lamp	White
rear position lamp	Red
rear fog lamp	Red
parking lamp	White in front, Red at the rear, Amber if reciprocally incorporated in the side direction-indicator lamps or in the side-marker lamps.
side-marker lamp	amber; however the rearmost side- marker lamp can be red if it is grouped or combined or reciprocally incorporated with the rear position lamp, the rear end-outline marker lamp, the rear fog lamp, the stop lamp or is grouped or has part of the light emitting surface in common with the rear retro-reflector.
end-outline marker lamp:	White in front, red at the rear
daytime running lamp	White
rear retro-reflector, non- triangular	Red

rear retro-reflector, triangular:	Red
front retro-reflector, non- triangular	White or colourless
side retro-reflector, non- triangular	Amber; however the rearmost side retro-reflector can be red if it is grouped or has part of the light emitting surface in common with the rear position lamp, the rear end-outline marker lamp, the rear fog lamp, the stop-lamp or the red rearmost side-marker lamp or the rear retro reflector, non-triangular
cornering lamp	White
Conspicuity marking	White to the front Yellow to the side Red to the rear
Adaptive front- lighting systems (AFS)	White
Exterior courtesy lamp	White
Maneuvering lamp	White

5.16 **Number of lamps**

5.16.1. The number of lamps mounted on the vehicle shall be equal to the number indicated in the individual specifications of this standard

5.17. Any lamp may be installed on movable components provided that the conditions specified in paragraphs 5.18., 5.19. and 5.20 are fulfilled.

5.18. Rear position lamps, rear direction-indicators and rear retro-reflectors, triangular as well as non-triangular, may be installed on movable components only:

5.18.1. If at all fixed positions of the movable components the lamps on the movable components meet all the position, geometric visibility, colorimetric and photometric requirements for those lamps.

5.18.2. In the case where the functions referred to in paragraph 5.18. are obtained by an assembly of two lamps marked "D" (see paragraph 2.16.1.), only one of the lamps needs to meet the position, geometric visibility and photometric requirements for those lamps at all fixed positions of the movable components.

or

5.18.3. Where additional lamps for the above functions are fitted and are activated, when the movable component is in any fixed open position, provided that these additional lamps satisfy all the position, geometric visibility and photometric requirements applicable to the lamps installed on the movable component.

5.18.4. In the case where the functions referred to in paragraph 5.18. are obtained by an interdependent lamp system either of the following conditions shall apply:

(a) Should the complete interdependent lamp system be mounted on the moving component(s), the requirements of paragraph 5.18.1 shall be satisfied. However, additional lamps for the above functions may be activated, when the movable component is in any fixed open position, provided that these additional lamps satisfy all the position, geometric visibility, colorimetric and photometric requirements applicable to the lamps installed on the movable component.

or

(b) Should the interdependent lamp system be partly mounted on the fixed component and partly mounted on a movable component, with the exception of direction indicator lamps, the interdependent lamp(s) specified by the applicant during the device approval procedure shall meet all the position, outwards geometric visibility, colorimetric and photometric requirements for those lamps, at all fixed positions of the movable component(s). The inwards geometric visibility requirement(s) is(are) deemed to be satisfied if this(these) interdependent lamp(s) still conform(s) to the photometric values prescribed in the field of light distribution for the approval of the device, at all fixed positions of the movable component(s).

For direction indicator lamps, the interdependent lamp(s) specified by the Applicant during the device approval procedure shall meet all the position, geometric visibility, photometric and colorimetric requirements at all fixed positions of the movable component(s). This does not apply where, to fulfil or complete the geometric visibility angle, additional lamps are activated when the movable component is in any fixed open position, provided that these additional lamps satisfy all the position, photometric and colorimetric requirements applicable to the direction indicator lamps installed on the movable component.

5.19. When the movable components are in a position of use other than a normal position the devices installed on them shall not cause undue discomfort to road users.

5.20. When a lamp is installed on a movable component and the movable component is in the "normal position(s) of use", the lamp shall always return to the position(s) specified by the manufacturer in accordance with this standard. In the case of dipped-beam headlamps and front fog lamps, this requirement shall be considered satisfied if, when the movable components are moved and returned to the normal position 10 times, no value of the angular inclination of these lamps, relative to its support, measured after each operation of the movable component, differs by more than 0.15 per cent from the average of the 10 measured values. If this value is exceeded each limit specified in paragraph 6.2.6.1.1. Shall then be modified by this excess to decrease the allowed range of inclinations when checking the vehicle according to Annex C.

- 5.21. The apparent surface in the direction of the reference axis of front and rear position lamps, front and rear direction-indicator lamps and retro-reflectors shall not be hidden more than 50 per cent by any movable component, with or without a light-signaling device installed on it, in any fixed position different from the "normal position of use".

Fixed position of a movable component means the stable or natural rest position(s) of the movable component specified by the vehicle manufacturer, whether locked or not.

If the above requirement is not practicable:

- 5.21.1. Additional lamps satisfying all the position, geometric visibility, colorimetric and photometric requirements for the above indicated lamps shall be activated when the apparent surface in the direction of the reference axis of these lamps is more than 50 per cent hidden by the movable component; or
- 5.21.2. A remark in the technical information to be submitted by the vehicle manufacturer/ test report (see paragraph 7.0) shall inform other Administrations that more than 50 per cent of the apparent surface in the direction of the reference axis can be hidden by the movable components; and

A notice in the vehicle shall inform the user that in certain position(s) of the movable components other road users shall be warned of the presence of the vehicle on the road; for example by means of a warning triangle or other devices according to national requirements for use on the road.

- 5.21.3. Paragraph 5.21.2. does not apply to retro-reflectors.

- 5.22. With the exception of retro-reflectors, a lamp even type approved is deemed not to be present when it cannot be made to operate by the sole installation of a light source and/or a fuse.

- 5.23 Lamps approved with light source(s) according to Standard AIS 034 (Part 1), except when such light sources are used as non-replaceable light source(s) as defined in paragraph 2.7.1.1.2. of this Standard, shall be fitted in a vehicle in such a way that the light source can be correctly replaced without the need for expert assistance and without the need for special tools, other than those provided with the vehicle by the manufacturer. The vehicle manufacturer shall provide with the vehicle a detailed description of the procedure for replacement.

Note : Standard tools like spanner, allen key, screw-drivers etc. are not considered as special tools. In case special tools are necessary vehicle manufacturers to provide the same.

- 5.24. Any temporary fail-safe replacement of the light-signaling function of a rear position lamp is allowed, provided that the replacement function in case of a failure is similar in colour, main intensity and position to the function that has ceased to operate and provided that the replacement device remains operational in its original safety function. During replacement, a tell-tale on the dashboard (paragraph 2.18. of

this standard) shall indicate occurrence of a temporary replacement and need for repair.

- 5.25. Where an AFS is fitted, it shall be considered equivalent to a pair of dipped-beam headlamps and, if it provides main-beam function(s), it shall be considered equivalent to a pair of main-beam headlamps.
- 5.26. Rear direction-indicator lamps, rear position lamps, stop lamps (except stop lamps of category S4) and rear fog lamps with variable luminous intensity control are allowed, which respond simultaneously to at least one of the following external influences: ambient lighting, fog, snowfall, rain, spray, dust clouds, contamination of the light emitting surface, provided that their prescribed intensity relationship is maintained throughout variation transitions. No sharp variation of intensity shall be observed during transition. Stop lamps of category S4 may produce variable luminous intensity independent from the other lamps. It may be possible for the driver to set the functions above to luminous intensities corresponding to their steady category and to return them to their automatic variable category.
- 5.27. For vehicles of M and N categories the applicant shall demonstrate to the test agency responsible for type approval testing that the electric power supply conditions for the devices indicated in 2.7.9., 2.7.10., 2.7.12., 2.7.14. and 2.7.15. above comply, when the electrical system of the vehicle is in a constant voltage operating condition, representative for the relevant category of powered vehicle as specified by the applicant, with the following provisions:
- 5.27.1. The voltage supplied at the terminals of devices which, according to their type approval documentation, have been tested by the application of a special power supply/electronic light source control gear, or in a secondary operating mode or at a voltage requested by the applicant, shall not exceed the voltage specified for the relevant devices or functions as they have been approved;
- 5.27.2. In all cases of electric power supply conditions not covered by paragraph 5.27.1., the voltage at the terminals of the device(s) or function(s) shall not exceed 6.75V (6 Volt-Systems), 13.5V (12 Volt-Systems) or 28.V (24 Volt-Systems) by more than 3 percent; The means of controlling the maximum voltage at the terminals of the device may, for convenience, be located within the body of the device.
- 5.27.3. The provisions of paragraphs 5.27.1. and 5.27.2. shall not apply to devices which include an electronic light source control gear or a variable intensity control being part of the device;
- 5.27.4. A report shall be attached to the approval documentation describing the methods used to demonstrate compliance and the results obtained.
- 5.28. **General provisions relating to geometric visibility**
- 5.28.1. There shall be no obstacle on the inside of the angles of geometric visibility to the propagation of light from any part of the apparent surface of the lamp observed from infinity. However, no account is taken of obstacles, if they were already presented when the lamp was type-approved.

- 5.28.2. If measurements are taken closer to the lamp, the direction of observation shall be shifted parallel to achieve the same accuracy.
- 5.28.3. If, when the lamp is installed, any part of the apparent surface of the lamp is hidden by any further parts of the vehicle, proof shall be furnished that the part of the lamp not hidden by obstacles still conforms to the photometric values prescribed for the approval of the device.
- 5.28.4. When the vertical angle of geometric visibility below the horizontal may be reduced to 5° (lamp at less than 750 mm above the ground) the photometric field of measurements of the installed optical unit may be reduced to 5° below the horizontal.
- 5.28.5. In the case of an interdependent lamp system the geometric visibility requirements shall be fulfilled when all its interdependent lamps are operated together.
- 5.29 A LED module does not need to be replaceable, if so stated in the communication sheet of the component type approval.

6.0 INDIVIDUAL SPECIFICATIONS

6.1. Main-Beam Headlamp

6.1.1. Presence

Mandatory on all motor vehicles of category L7, M & N.

Prohibited on trailers.

6.1.2. Number

Two or four, type approved according to standard AIS-010, excluding Class A headlamp.

For vehicles of the category N3: Two extra main-beam headlamps may be installed.

Where a vehicle is fitted with four concealable headlamps the installation of two additional headlamps shall only be authorized for the purpose of light-signaling, consisting of intermittent illumination, at short intervals (see paragraph 5.12.) in daylight.

6.1.3. Arrangement

No individual specifications.

6.1.4. Position

6.1.4.1. Width: No individual specifications.

6.1.4.2. Height: No individual specifications.

6.1.4.3. Length: At the front of the vehicle. This requirement shall be deemed to be satisfied if the light emitted does not cause discomfort to the driver either directly or indirectly through devices for indirect vision and/or other reflecting surfaces of the vehicle.

6.1.5. **Geometric visibility**

The visibility of the illuminating surface, including its visibility in areas which do not appear to be illuminated in the direction of observation considered, shall be ensured within a divergent space defined by generating lines based on the perimeter of the illuminating surface and forming an angle of not less than 5° with the axis of reference of the headlamp. The origin of the angles of geometric visibility is the perimeter of the projection of the illuminating surface on a transverse plane tangent to the foremost part of the lens of the headlamp.

6.1.6. **Orientation**

Towards the front

6.1.6.1 Not more than one main-beam headlamp on each side of the vehicle may swivel to produce bend lighting.

6.1.7. **Electrical connections**

6.1.7.1. Except when they are used to give intermittent luminous warnings at short intervals the main-beam headlamps may be switched ON, only when the master light switch is in headlamps ON position or in "AUTO" (automatic) position and the conditions for automatic activation of dipped-beam exist. In the latter case, the main beam headlamps shall be switched off automatically when the conditions for automatic activation of dipped-beam ceased to exist.

6.1.7.2. The control of the main-beam headlamps may be automatic regarding their activation and deactivation, the control signals being produced by a sensor system which is capable of detecting and reacting to each of the following inputs:

- (a) Ambient lighting conditions;
- (b) The light emitted by the front lighting devices and front light-signaling devices of oncoming vehicles;
- (c) The light emitted by the rear light-signaling devices of preceding vehicles.

Additional sensor functions to improve performance are allowed.

For the purpose of this paragraph, "vehicles" means vehicles of categories L, M, N, T, as well as bicycles, such vehicles being equipped with retro-reflectors, with lighting and light-signaling devices, which are switched ON.

6.1.7.3. It shall always be possible to switch the main-beam headlamps ON and OFF manually and to manually switch OFF the automatic control of the main beam head lamps.

Moreover, the switching OFF, of the main-beam headlamps and of their automatic control, shall be by means of a simple and immediate manual operation; the use of sub-menus is not allowed.

6.1.7.4 The main-beam headlamps may be switched on either simultaneously or in pairs. In case the extra two main-beam headlamps are installed, as permitted under paragraph 6.1.2. for vehicles of the category N3 only, no more than two pairs may be simultaneously lit. For changing over from the dipped to the main beam at least one pair of main-beam headlamps shall be switched on. For changing over from the main-beam to the dipped-beam all main- beam headlamps shall be switched off simultaneously.

6.1.7.5 The dipped-beams may remain switched on at the same time as the main beams.

6.1.7.6 Where four concealable headlamps are fitted their raised position shall prevent the simultaneous operation of any additional headlamps fitted, if these are intended to provide light signals consisting of intermittent illumination at short intervals (paragraph 5.12.) in daylight.

6.1.8. **Tell-tale**

Circuit-closed tell-tale mandatory.

6.1.8.1. If the control of the main-beam headlamps is automatic as described in paragraph 6.1.7.1. above an indication shall be provided to the driver that the automatic control of the main- beam function is activated. This information shall remain displayed as long as the automatic operation is activated.

6.1.9. **Other requirements**

6.1.9.1. The aggregate maximum intensity of the main-beam headlamps which can be switched on simultaneously shall not exceed 430,000 cd which corresponds to a reference value of 100.

6.1.9.2. This maximum intensity shall be obtained by adding together the individual reference marks which are indicated on the several headlamps. The reference mark shall be given to each of the headlamps as per AIS-012.

6.1.9.3. Automatic activation and deactivation of the main-beam headlamps:

6.1.9.3.1. The sensor system used to control the automatic activation and deactivation of the main- beam headlamps, as described in paragraph 6.1.7.1., shall comply with the following requirements

6.1.9.3.1.1. The boundaries of the minimum fields in which the sensor is able to detect light emitted from other vehicles defined in paragraph 6.1.7.1. are defined by the angles indicated below.

6.1.9.3.1.1.1. Horizontal angles: 15° to the left and 15° to the right.

Vertical angles :			
Upward angle	5°		
Mounting height of the sensor (Centre of sensor aperture above the ground)	Less than 2 m	Between 1.5 m and 2.5 m	Greater than 2.0 m
Downward angle	2	2° to 5°	5

These angles are measured from the centre of the sensor aperture relative to a horizontal straight line through its centre and parallel to the longitudinal median plane of the vehicle.

- 6.1.9.3.1.2. The sensor system shall be able to detect on a straight level road:
- (a) An oncoming power driven vehicle at a distance extending to at least 400 m;
 - (b) A preceding power driven vehicle or a vehicle-trailers combination at a distance extending to at least 100 m;
 - (c) An oncoming bicycle at a distance extending to at least 75 m, its illumination represented by a white lamp with a luminous intensity of 150 cd with a light emitting area of $10 \text{ cm}^2 \pm 3 \text{ cm}^2$ and a height above a ground of 0.8 m.

To verify compliance with (a) and (b) above, the oncoming and preceding power driven vehicle (or vehicle-trailer combination) shall have position lamps (if applicable) and dipped-beam headlamps switched ON.

- 6.1.9.3.2. The transition from main-beam to dipped-beam and vice versa according to the conditions indicated in paragraph 6.1.7.1. above may be performed automatically and shall not cause discomfort, distraction or glare.

- 6.1.9.3.3. The overall performance of the automatic control shall be verified by:

- 6.1.9.3.3.1. Means of simulation or other means of verification accepted by the test agency responsible for type approval testing, as provided by the applicant.

- 6.1.9.3.3.2. A test drive according to paragraph 1 in Annex G. The performance of the automatic control shall be documented and checked against the applicant's description. Any obvious malfunctioning shall be contested (e.g. excessive angular movement or flicker).

The control of the main-beam headlamps may be such that the main-beam headlamps are switched ON automatically only when:

- (a) No vehicles, as mentioned in paragraph 6.1.7.1. above, are detected within the fields and distances according to paragraphs 6.1.9.3.1.1. and 6.1.9.3.1.2.; and
 - (b) The detected ambient lighting levels are as prescribed in paragraph 6.1.9.3.5. below.
- 6.1.9.3.5. In the case where main-beam headlamps are switched ON automatically, they shall be switched OFF automatically when oncoming or preceding vehicles, as mentioned in paragraph 6.1.7.1. above, are detected within the fields and distances according to paragraphs 6.1.9.3.1.1. and 6.1.9.3.1.2.

Moreover, they shall be switched OFF automatically when the illuminance produced by ambient lighting conditions exceeds 7000 lx.

Compliance with this requirement shall be demonstrated by the applicant, using simulation or other means of verification accepted by the test agency responsible for type approval. If necessary the illuminance shall be measured on a horizontal surface, with a cosine corrected sensor on the same height as the mounting position of the sensor on the vehicle. This may be demonstrated by the manufacturer by sufficient documentation or by other means accepted by the test agency responsible for type approval.

6.2. **Dipped-beam headlamp**

6.2.1. **Presence**

Mandatory on motor vehicles. Prohibited on trailers.

6.2.2. **Number**

Two, type approved according to Standard AIS-010, excluding Class A headlamp.

6.2.3. **Arrangement**

No special requirement.

6.2.4. **Position**

6.2.4.1. Width: That edge of the apparent surface in the direction of the reference axis which is farthest from the vehicle's median longitudinal plane shall be not more than 400 mm from the extreme outer edge of the vehicle.

The inner edges of the apparent surfaces in the direction of the reference axes shall be not less than 600 mm apart. This does not apply, however, for L7, M1 and N1 category vehicles; for all other categories of motor vehicles this distance may be reduced to 400 mm where the overall width of the vehicle is less than 1,300 mm.

6.2.4.2. Height: not less than 500 mm and not more than 1,200 mm above the ground. For category N3G (off-road) vehicles the maximum height may be increased to 1,500 mm.

6.2.4.3. Length: at the front of the vehicle. This requirement shall be deemed to be satisfied if the light emitted does not cause discomfort to the driver either directly, or indirectly through the devices for indirect vision and/or other reflecting surfaces of the vehicle.

6.2.5. **Geometric visibility**

6.2.5.1 Defined by angles α and β as specified In paragraph 2.13.

6.2.5.2 $\alpha = 15^\circ$ upwards and 10° downwards

6.2.5.3 $\beta = 45^\circ$ outwards and 10° inwards

6.2.5.4 The presence of partitions or other items of equipment near the headlamp shall not give rise to secondary effects causing discomfort to other road users.

6.2.6. **Orientation**

Towards the front

6.2.6.1. **Vertical orientation**

6.2.6.1.1. The initial downward inclination of the cut-off of the dipped-beam to be set in the unladen vehicle state with one person in the driver's seat shall be specified within an accuracy of 0.1 per cent by the manufacturer and indicated in a clearly legible and indelible manner on each vehicle close to either headlamp or the manufacturer's plate by the symbol shown in Annex A.

The value of this indicated downward inclination shall be defined in accordance with paragraph 6.2.6.1.2.

6.2.6.1.2. Depending on the mounting height in meter's (h) of the lower edge of the apparent surface in the direction of the reference axis of the dipped-beam headlamp, measured on the unladen vehicles, the vertical inclination of the cut-off of the dipped-beam shall, under all the static conditions of Annex B, remain between the following limits and the initial aiming shall have the following values:

$h < 0.8$

Limits: between -0.5 per cent and -2.5 per cent

Initial aiming: between -1.0 per cent and -1.5 per cent

$0.8 < h < 1.0$

Limits: between -0.5 per cent and -2.5 per cent

Initial aiming: between -1.0 per cent and -1.5 per cent

Or, at the discretion of the manufacturer,

Limits: between -1.0 per cent and -3.0 per cent

Initial aiming: between -1.5 per cent and -2.0 per cent

The application for the vehicle type-approval shall, in this case, contain information as to which of the two alternatives is to be used.

$h > 1.0$

Limits: between -1.0 per cent and -3.0 per cent

Initial aiming: between -1.5 per cent and -2.0 per cent

The above limits and the initial aiming values are summarized in the diagram below.

For category N3G (off-road) vehicles where the headlamps exceed a height of 1,200 mm, the limits for the vertical inclination of the cut-off shall be between: -1.5 per cent and -3.5 per cent.

The initial aim shall be set between:
-2 per cent and -2.5 per cent.

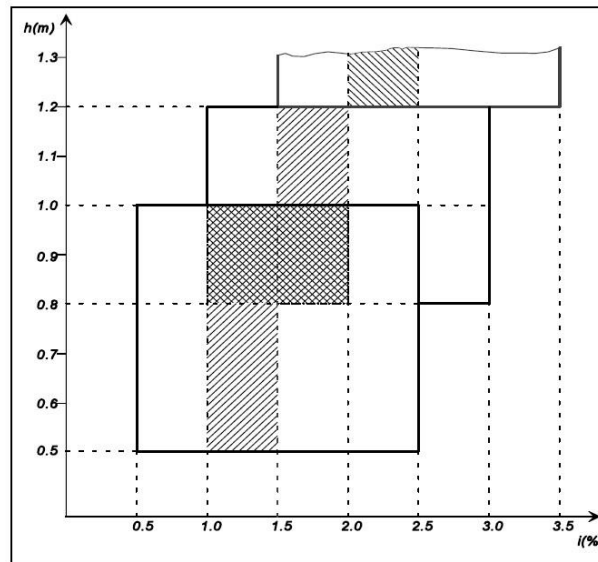

6.2.6.2 **Headlamp levelling device (not applicable for quadricycles)”**

6.2.6.2.1. In the case where a headlamp levelling device is necessary to satisfy the requirements of paragraphs 6.2.6.1.1. and 6.2.6.1.2., the device shall be automatic.

6.2.6.2.2. However, devices which are adjusted manually, either continuously or non-continuously, shall be permitted, provided they have a stop position at which the lamps shall be returned to the initial inclination defined in paragraph 6.2.6.1.1. by means of the usual adjusting screws or similar means. These manually adjustable devices shall be operable from the driver's seat.

Continually adjustable devices shall have reference marks indicating the loading conditions that require adjustment of the dipped-beam.

The number of positions on devices which are not continuously adjustable shall be such as to ensure compliance with the range of values prescribed in paragraph 6.2.6.1.2. in all the loading conditions defined in Annex B.

For these devices also, the loading conditions of Annex B that require adjustment of the dipped-beam shall be clearly marked near the control of the device (Annex D).

6.2.6.2.3. In the event of a failure of devices described in paragraphs 6.2.6.2.1. and 6.2.6.2.2., the dipped-beam shall not assume a position in which the dip is less than it was at the time when the failure of the device occurred.

6.2.6.3. **Measuring procedure**

6.2.6.3.1. After adjustment of the initial inclination, the vertical inclination of the dipped-beam, expressed in per cent, shall be measured in static conditions under all the loading conditions defined in Annex B.

6.2.6.3.2. The measurement of the variation of dipped-beam inclination as a function of load shall be carried out in accordance with the test procedure set out in Annex C.

6.2.6.4. **Horizontal orientation**

The horizontal orientation of one or both dipped-beam headlamps may be varied to produce bend lighting, provided that if the whole beam or the kink of the elbow of the cut-off is moved, the kink of the elbow of the cut-off shall not intersect the line of the trajectory of the center of gravity of the vehicle at distances from the front of the vehicle which are larger than 100 times the mounting height of the respective dipped-beam headlamps.

6.2.7. **Electrical connections**

6.2.7.1. The control for changing over to the dipped-beam shall switch off all main-beam headlamps simultaneously.

6.2.7.2. The dipped-beam may remain switched on at the same time as the main beams.

6.2.7.3. In the case of dipped-beam headlamps according to standard AIS 034, the gas-discharge light sources shall remain switched on during the main-beam operation.

6.2.7.4. One additional light source or one or more LED module(s), located inside the dipped-beam headlamps or in a lamp (except the main-beam headlamp) grouped or reciprocally incorporated with the respective dipped-beam headlamps, may be activated to produce bend lighting, provided that the horizontal radius of curvature of the trajectory of the center of gravity of the vehicle is 500 m or less. This may be demonstrated by the manufacturer by calculation or by other means accepted by the test agency responsible for type approval.

6.2.7.5. Dipped-beam headlamps may be switched ON or OFF automatically. However, it shall be always possible to switch these dipped-beam headlamps ON and OFF manually.

6.2.7.6. If daytime running lamps are present and operate according to paragraph 6.19., either

6.2.7.6.1. The dipped-beam headlamps may be switched ON and OFF automatically relative to the ambient light conditions (e.g. switch ON during night-time driving conditions, tunnels, etc.) according to the requirements of Annex H; or

6.2.7.6.2. Daytime running lamps operate in conjunction with the lamps listed in paragraph 5.11. Where, as a minimum requirement, at least the rear position lamps shall be activated; or

6.2.7.6.3. Distinctive means are provided to inform the driver that the headlamps, position lamps and if so equipped end outline marker lamps and side marker lamps are not illuminated. Such means are:

- 6.2.7.6.3.1. Two distinctly different levels of instrument panel illumination intensity are provided during night and day, indicating to the driver that the dipped-beam headlamps shall be switched ON; or
- 6.2.7.6.3.2. Non-illuminated indicators and identification of hand controls that are required by Standard AIS 071 to be illuminated when the headlamps are activated; or
- 6.2.7.6.3.3. A tell-tale visual, auditory or both, shall be activated only in reduced ambient lighting conditions as defined in Annex H to inform the driver that the dipped-beam headlamps should be switched ON. Once the tell-tale is activated, it shall only be extinguished when the dipped-beam headlamps have been switched on or the device which starts and/or stops the engine (propulsion system) is set in a position which makes it impossible for the engine (propulsion system) to operate.
- 6.2.7.7. Without prejudice to paragraph 6.2.7.6.1., the dipped-beam headlamps may switch ON and OFF automatically relative to other factors such as time or ambient conditions (e.g. time of the day, vehicle location, rain, fog, etc.)

6.2.8. **Tell-tale**

6.2.8.1. Tell-tale optional.

6.2.8.2. A visual tell-tale whether flashing or not is mandatory:

- (a) In the case where the whole beam or the kink of the elbow of the cut-off is moved to produce bend lighting; or
- (b) If one or more LED modules are used to produce the principal dipped-beam. It shall be activated:
 - (a) In the event of a malfunction of the displacement of the kink of the elbow of the cut-off; or
 - (b) In case of a failure of any one of the LED module(s) producing the principal dipped-beam.

It shall remain activated while the failure is present. It may be cancelled temporarily, but shall be repeated whenever the device, which starts and stops the engine, is switched on and off.

6.2.9. **Other requirements**

The requirements of paragraph 5.5.2. shall not apply to dipped-beam headlamps.

Dipped-beam headlamps with a light source or LED module(s) producing the principal dipped-beam and having a total objective luminous flux which exceeds 2,000 lumen shall be installed in conjunction with the installation of headlamp cleaning device(s) according to Standard AIS-083.

With respect to vertical inclination the provisions of paragraph 6.2.6.2.2. Above shall not be applied for dipped-beam headlamps with a light source or LED module(s) producing the principal

dipped-beam, and having an objective luminous flux which exceeds 2,000 lumens.

In the case of filament lamps for which more than one test voltage is specified, the objective luminous flux which produces the principal dipped-beam, as indicated in the technical specification for the type approval of the device, is applied.

In the case of dipped-beam headlamps equipped with an approved light source, the applicable objective luminous flux is the value at the relevant test voltage as given in the relevant data sheet in the Standard, according to which the applied light source was approved, without taking into account the tolerances to the objective luminous flux specified on this datasheet.

Certifying agency can still prohibit the use of mechanical cleaning systems when headlamps with plastic lenses, marked "PL", are installed.

Only dipped-beam headlamps according to standard AIS-012 may be used to produce bend lighting.

If bend lighting is produced by a horizontal movement of the whole beam or the kink of the elbow of the cut-off, it shall be activated only if the vehicle is in forward motion; this shall not apply if bend lighting is produced for a left turn in left hand traffic

6.3 **Front fog lamp**

6.3.1. **Presence**

Optional on motor vehicles. Prohibited on trailers.

6.3.2. **Number**

Two; complying with the requirements of AIS-012.

6.3.3. **Arrangement**

No special requirement.

6.3.4. **Position**

6.3.4.1. **Width:** That point on the apparent surface in the direction of the reference axis which is farthest from the vehicle's median longitudinal plane shall not be more than 400 mm from the extreme outer edge of the vehicle.

6.3.4.2. **Height:**

Minimum: Not less than 250 mm above the ground.

Maximum: For L7, M1 and N1 category vehicles: not more than 800 mm above the ground.

For all other categories except N3G off-road vehicles: not more than 1,200 mm above the ground.

For category N3G vehicles: the maximum height may be increased to 1,500 mm.

No point on the apparent surface in the direction of the reference axis must be higher than the highest point on the apparent surface in the direction of the reference axis of the dipped-beam headlamp.

- 6.3.4.3. **Length:** At the front of the vehicle. This requirement shall be deemed to be satisfied if the light emitted does not cause discomfort to the driver either directly, or indirectly through the devices for indirect vision and/or other reflecting surfaces of the vehicle.
- 6.3.5 **Geometric visibility**
 Defined by angles α and β as specified in paragraph 2.13.,
 $\alpha = 5^\circ$ upwards and downwards,
 $\beta = 45^\circ$ outwards and 10° inwards.
 The presence of partitions or other items of equipment near the front fog lamp shall not give rise to secondary effects causing discomfort to other road users.
- 6.3.6. **Orientation**
 Towards the front.
- 6.3.6.1. **Vertical orientation**
 - 6.3.6.1.1. In the case of class "B" front fog lamps the vertical inclination of the cut-off to be set in the unladen vehicle state with one person in the driver's seat. It shall be -1.5 per cent or lower.
 - 6.3.6.1.2. In the case of class "F3" front fog lamps:
 - 6.3.6.1.2.1. When the total objective luminous flux of the light source does not exceed 2,000 lumens:
 - 6.3.6.1.2.1.1. The vertical inclination of the cut-off to be set in the unladen vehicle state with one person in the driver's seat. It shall be - 1.0 per cent or lower.
 - 6.3.6.1.2.2. When the total objective luminous flux of the light source exceeds 2,000 lumens:
 - 6.3.6.1.2.2.1. Depending on the mounting height in metres (h) of the lower edge of the apparent surface in the direction of the reference axis of the front fog lamp, measured on the unladen vehicles, the vertical inclination of the cut-off shall under all the static conditions of Annex B automatically remain between the following values:

$h \leq 0.8$	
Limits:	between -1.0 per cent and -3.0 per cent
Initial aiming:	between -1.5 per cent and -2.0 per cent
$h > 0.8$	
Limits:	between -1.5 per cent and -3.5 per cent
Initial aiming:	between -2.0 per cent and -2.5 per cent.

6.3.6.1.2.2.2. The initial downward inclination of the cut-off to be set in the unladen vehicle state with one person in the driver's seat shall be specified within an accuracy of one decimal place by the manufacturer and indicated in a clearly legible and indelible manner on each vehicle close to either the front fog lamp or the manufacturer's plate or in combination with the indication referred to in paragraph 6.2.6.1.1. by the symbol shown in Annex A to this standard The value of this indicated downward inclination shall be defined in accordance with paragraph 6.3.6.1.2.2.1.

6.3.6.2. **Front fog lamp levelling device**

6.3.6.2.1. Where a levelling device is fitted for a front fog lamp, independent or grouped with other front lighting and light signalling functions, it shall be such that the vertical inclination, under all the static loading conditions of Annex B of this standard, shall remain between the limits prescribed in paragraph 6.3.6.1.2.2.1.

6.3.6.2.2. In the case where the front fog lamp of category "F3" is part of the dipped-beam headlamp or is part of an AFS system, the requirements of paragraph 6.2.6. shall be applied during the use of the front fog beam as part of the dipped-beam.

In this case the levelling limits defined in paragraph 6.2.6. may be applied also when this front fog lamp is used as such.

6.3.6.2.3. The levelling device may also be used to automatically adapt the inclination of the front fog beam in relation to the prevailing ambient conditions, provided that the limits for the downward inclination specified in paragraph 6.3.6.1.2.2.1. are not exceeded.

6.3.6.2.4. In the case of a failure of the levelling device, the front fog beam shall not assume a position in which the cut off is less inclined than it was at the time when the failure of the device occurred.

6.3.7. **Electrical connections**

It shall be possible to switch the front fog lamps ON and OFF independently of the main- beam headlamps, the dipped-beam headlamps or any combination of main- and dipped-beam headlamps, unless

(a) The front fog lamps are used as part of another lighting function in an AFS; however, the switching ON of the front fog lamps function shall have the priority over the function for which the front fog lamps are used as a part, or

(b) The front fog lamps cannot be simultaneously lit with any other lamps with which they are reciprocally incorporated

6.3.8. **Tell-tale**

Circuit-closed tell-tale mandatory. An independent non-flashing warning light.

6.3.9. **Other requirements**

In the case where there is a positive indication in the communication form in item 9.11 of Annex 1 of Standard AIS-012 (Part 1) (Rev.1) the alignment and the luminous intensities of the class "F3" front fog beam may be automatically adapted in relation to the prevailing ambient conditions. Any variations of the luminous intensities or alignment shall be performed automatically and in such a way that no discomfort, neither for the driver nor to other road users, is caused.

6.4. **Reversing Lamp**

6.4.1. **Presence**

Mandatory on motor vehicles and on trailers of categories T2, T3 and T4. Optional on trailers of category T1.

6.4.2. **Number**

6.4.2.1. One device mandatory and a second device optional on motor vehicles of category L7-M, M1 and on all other vehicles with a length not exceeding 6,000 mm.

6.4.2.2. Two devices mandatory and two devices optional on all vehicles with a length exceeding 6,000 mm, except vehicles of category M1 and L7- M".

6.4.3. **Arrangement**

No special requirement.

6.4.4. **Position**

6.4.4.1. **Width:** no special requirement.

6.4.4.2. **Height:** not less than 250 mm and not more than 1,200 mm above the ground.

6.4.4.3. **Length:** at the rear of the vehicle.

However, if installed, the two optional devices mentioned in paragraph 6.4.2.2 may be fitted on the vehicle provided that the requirements of paragraphs 6.4.5.2. and 6.4.6.2. Below are fulfilled.

6.4.5. **Geometric visibility**

6.4.5.1. Devices installed at the rear of the vehicle:

Defined by angles α and β , as specified in paragraph 2.13.:

$\alpha = 15^\circ$ upwards and 5° downwards,

$\beta = 45^\circ$ to right and to left if there is only one device

45° outwards and 30° inwards if there are two

6.4.5.2. Two optional devices mentioned in paragraph 6.4.2.2. if fitted on the side of the vehicle:

The geometric visibility is considered to be ensured if the reference axis of the respective device is directed outwards with an angle β not exceeding 15° relative to the median longitudinal plane of the vehicle. The vertical aim of the two optional devices may be directed downwards.

6.4.6. **Orientation**

6.4.6.1. Rearwards

6.4.6.2 In addition if the two optional devices mentioned in paragraph 6.4.2.2., if are fitted on the side of the vehicle, the above-mentioned provisions of paragraph 6.4.5 above shall apply.

6.4.7. **Electrical connections**

6.4.7.1. They shall be such that the lamp can light up only if the reverse gear is engaged and if the device which controls the starting and stopping of the engine is in such a position that operation of the engine is possible. It shall not light up or remain lit if either of the above conditions is not satisfied.

6.4.7.2. Moreover, the electrical connections of the two optional devices mentioned in paragraph 6.4.2.2. Shall be such that these devices cannot illuminate unless the lamps referred to in paragraph 5.11. are switched on.

The devices fitted on the side of the vehicle may be switched on for slow manoeuvres in forward motion of the vehicle up to a maximum speed of 10 km/h, provided that the following conditions are fulfilled:

- (a) The devices shall be activated and deactivated manually by a separate switch;
- (b) If so activated, they may remain illuminated after reverse gear is disengaged;
- (c) They shall be automatically switched off if the forward speed of the vehicle exceeds 10 km/h, regardless of the position of the separate switch; in this case they shall remain switched off until deliberately being switched on again.

6.4.8. **Tell-tale**

Tell-tale optional.

6.4.9. **Other requirements**

None.

6.5. **Direction-indicator lamp**

6.5.1. **Presence**

Mandatory. Different categories of direction-indicator lamps viz., 1, 1a, 1b, 2a, 2b, 5 and 6 (as defined in AIS-012) are shown in figure below. The assembly of which on one vehicle constitutes an arrangement ("A" and B").

Arrangement "A" shall apply to all motor vehicles.

Arrangement "B" shall apply to trailers only.

6.5.2. **Number**

According to the arrangement.

6.5.3. **Arrangements (see figure below)**

For all motor vehicles of category L7, M & N

A: Two front direction-indicator lamps of the following categories:

1 or 1a or 1b,

If the distance between the edge of the apparent surface in the direction of the reference axis of this lamp and that of the apparent surface in the direction of the reference axis of the dipped- beam headlamp and/or the front fog lamp, if there is one, is at least 40 mm;

1a or 1b,

If the distance between the edge of the apparent surface in the direction of the reference axis of this lamp and that of the apparent surface in the direction of the reference axis of the dipped-beam headlamp and/or the front fog lamp, if there is one, is greater than 20 mm and less than 40 mm;

1b,

If the distance between the edge of the apparent surface in the direction of the reference axis of this lamp and that of the apparent surface in the direction of the reference axis of the dipped-beam headlamp and/or the front fog lamp, if there is one, is less than or equal to 20 mm;

Two rear direction-indicator lamps (category 2a or 2b);

Two optional lamps (category 2a or 2b) on all vehicles in categories M2, M3, N2, N3.

Two Side direction-indicator lamps of the categories 5 or 6 (minimum requirements)

5

For all L7 and M1 vehicles;

For N1, M2 and M3 vehicles not exceeding 6 metres in length.

6

For all N2 and N3 vehicles;

For N1, M2 and M3 vehicles exceeding 6 metres in length.

It is permitted to replace category 5 side direction-indicator lamps by category 6 side direction-indicator lamps in all instances

A maximum of three optional category 5 or one optional category 6 device per side on vehicles of type M2, M3, N2 and N3 exceeding 9 m in length.

Where lamps combining the functions of front direction-indicator lamps (categories 1, 1a, 1b) and side direction-indicator lamps (categories 5 or 6) are fitted, two additional side direction- indicator lamps (categories 5 or 6) may be fitted to meet the visibility requirements of paragraph 6.5.5.

B: two rear direction-indicator lamps (Categories 2a or 2b)

Two optional lamps (category 2a or 2b) on all vehicles in categories T2, T3 and T4.

A maximum of three optional category 5 or one optional category 6 device per side on vehicles of type T2, T3 and T4 exceeding 9 m in length.

Where an AFS is fitted, the distance to be considered for the choice of the category is the distance between the front direction-indicator lamp and the closest lighting unit in its closest position contributing to or performing a passing-beam mode.

6.5.4. **Position**

6.5.4.1. **Width:** The edge of the apparent surface in the direction of the reference axis farthest from the median longitudinal plane of the vehicle shall not be more than 400 mm from the extreme outer edge of the vehicle. This condition shall not apply to the optional rear lamps.

The distance between the inner edges of the two apparent surfaces in the direction of the reference axes shall not be less than 600 mm.

This distance may be reduced to 400 mm where the overall width of the vehicle is less than 1,300 mm.

6.5.4.2. **Height:** above the ground.

6.5.4.2.1. The height of the light-emitting surface of the side direction-indicator lamps of categories 5 or 6 shall not be:

Less than: 350 mm for L7, M1 and N1 category of vehicles, and 500 mm for all other categories of vehicles, both measured from the lowest point; and

More than: 1,500 mm, measured from the highest point.

6.5.4.2.2. The height of the direction-indicator lamps of categories 1, 1a, 1b, 2a and 2b, measured in accordance with paragraph 5.8., shall not be less than 350 mm and not more than 1,500 mm.

6.5.4.2.3. If the structure of the vehicle does not permit these upper limits, measured as specified above, to be respected, and if the optional rear lamps are not installed, they may be increased to 2,300 mm for side direction-indicator lamps of categories 5 and 6, and to 2,100 mm for the direction-indicator lamps of categories 1, 1a, 1b, 2a and 2b.

6.5.4.2.4. If optional rear lamps are installed, they shall be placed at a height compatible with the applicable requirements of paragraph 6.5.4.1., the symmetry of the lamps, and at a vertical distance as large as the shape of the bodywork makes it possible, but not less than 600 mm above the mandatory lamps.

6.5.4.3 **Length** (see figure below)

The distance between the light-emitting surface of the side direction-indicator lamp (categories 5 and 6) and the transverse plane which marks the forward boundary of the vehicle's overall length, shall not exceed 1,800 mm.

However, this distance shall not exceed 2,500 mm:

(a) For M1 and N1 category vehicles;

- (b) For all other categories of vehicles if the structure of the vehicle makes it impossible to comply with the minimum angles of visibility.

Optional category 5 side direction indicator lamps, shall be fitted, spaced evenly, along the length of the vehicle.

Optional category 6 side direction indicator lamp shall be fitted in the area between the first and last quartiles of the length of a trailer.

6.5.5.

Geometric visibility

6.5.5.1.

Horizontal angles, (see figure below)

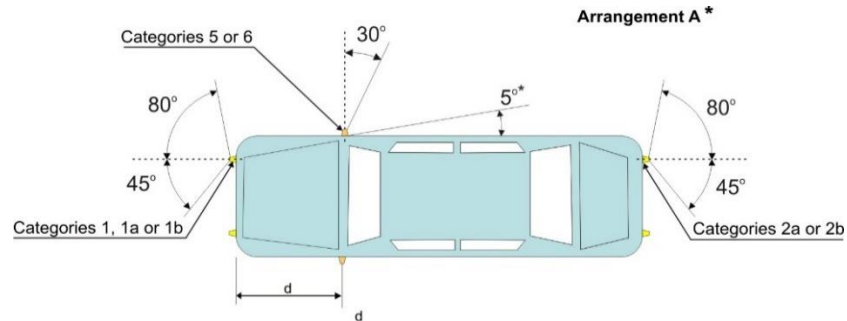

Vertical angles: 15° above and below the horizontal for direction-indicator lamps of categories 1, 1a, 1b, 2a, 2b and 5. The vertical angle below the horizontal may be reduced to 5° if the lamps are less than 750 mm above the ground; 30° above and 5° below the horizontal for direction-indicator lamps of category 6.

The vertical angle above the horizontal may be reduced to 5° if the optional rear lamps are not less than 2,100 mm above the ground.

For L7, M1 and N1 category vehicles, the value of 45° inward for the direction-indicator lamps of categories 1, 1a or 1b, whose lower edge of the apparent surface is less than 750 mm above the ground, may be reduced to 20° under the horizontal plane containing the reference axis of this lamp.

Schéma B

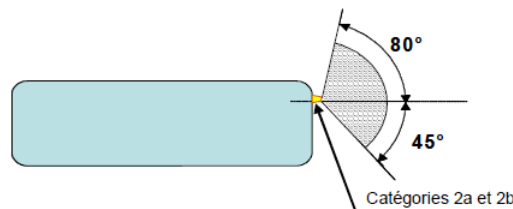

(*) The value of 5° given for dead angle of visibility to the rear of the side-direction- indicator is an upper limit $d \leq 1.80$ m (for L7, M1 and N1 category vehicles $d \leq 2.50$ m).

Note: The value of 5° given for dead angle of visibility to the rear of the side-direction indicator is an upper limit. $d < 2.50$ m.

6.5.5.2. Or, at the discretion of the manufacturer, for L7, M1 and N1 category vehicles:

Front and rear direction-indicator lamps, as well as side-marker lamps ()** Horizontal angles see figure below:

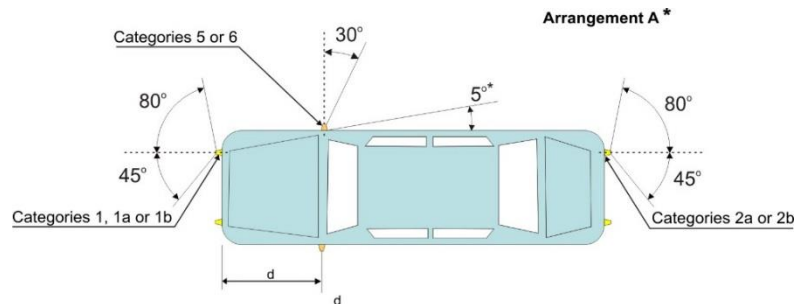

The value of 45° inward for the direction-indicator lamps of categories 1, 1a or 1b, whose lower edge of the apparent surface is less than 750 mm above the ground, may be reduced to 20° under the horizontal plane containing the reference axis of this lamp.

Vertical angles: 15° above and below the horizontal. The vertical angle below the horizontal may be reduced to 5° if the lamps are less than 750 mm above the ground.

To be considered visible, the lamp must provide an unobstructed view of the apparent surface of at least 12.5 square centimeters, except for side direction-indicators of categories 5 and 6. The illuminating surface area of any retro-reflector that does not transmit light shall be excluded.

6.5.6. **Orientation**

According to the specifications for installation by the manufacturer, if any.

6.5.7. **Electrical connections**

Direction-indicator lamps shall switch on independently of the other lamps. All direction- indicator lamps on one side of a vehicle shall be switched on and off by means of one control and shall flash in phase.

On M1 and N1 vehicles less than 6 m in length, with an arrangement complying with paragraph 6.5.5.2. above, the amber side-marker lamps, when mounted, shall also flash at the same frequency (in phase) with the direction-indicator lamps.

6.5.8. **Tell-tale**

Operating tell-tale mandatory for direction-indicator lamps of categories 1, 1a, 1b, 2a and 2b. It may be visual or auditory or both. If it is visual it shall be a flashing light which, at least in the event of the malfunction of these direction-indicator lamps, is either extinguished, or remains alight without flashing, or shows a marked change of frequency. If it is entirely auditory it shall be clearly audible and shall show a marked change of frequency, at least in the event of the malfunction of any of these direction- indicator lamps.

It shall be activated by the signal produced according to paragraph 6.2.2 of AIS-012 standard or another suitable way.

If a motor vehicle is equipped to draw a trailer, it shall be fitted with a special visual operational tell-tale for the direction-indicator lamps on the trailer unless the tell-tale of the drawing vehicle allows the failure of any one of the direction-indicator lamps on the vehicle combination thus formed to be detected.

For the optional direction-indicator lamps on motor vehicles and trailers, operating tell-tale shall not be mandatory.

6.5.9. **Other requirements**

The light shall be a flashing light flashing 90 ± 30 times per minute.

Operation of the light-signal control shall be followed within not more than one second by the emission of light and within not more than one and one-half seconds by its first extinction.

If a motor vehicle is equipped to draw a trailer, the control of the direction- indicator lamps on the drawing vehicle shall also operate the indicator lamps of the trailer. In the event of failure, other than short-circuit, of one direction-indicator lamp, the others shall continue to flash, but the frequency in this condition may be different from that prescribed.

6.6. **Hazard Warning Signal**

6.6.1. **Presence**

Mandatory.

The signal shall be given by simultaneous operation of the direction-indicator lamps in accordance with the requirements of paragraph 6.5. above.

6.6.2. **Number**

As specified in paragraph 6.5.2.

6.6.3. **Arrangement**

As specified in paragraph 6.5.3.

6.6.4. **Position**

6.6.4.1. **Width:** As specified in paragraph 6.5.4.1.

6.6.4.2. **Height:** As specified in paragraph 6.5.4.2.

6.6.4.3. **Length:** As specified in paragraph 6.5.4.3.

6.6.5. **Geometric visibility**

As specified in paragraph 6.5.5.

6.6.6. **Orientation**

As specified in paragraph 6.5.6.

6.6.7. **Electrical connections**

6.6.7.1. The signal shall be operated by means of a separate manual control enabling all the direction-indicator lamps to flash in phase.

- 6.6.7.2. The hazard warning signal may be activated automatically in the event of a vehicle being involved in a collision or after the de activation of the emergency stop signal, as specified in paragraph 6.23. In such cases, it may be turned "off" manually.

In addition, the hazard warning signal may be switched on automatically to indicate to other road-users the risk of imminent danger as defined by standard; in this case, the signal shall remain switched "on" until it is manually or automatically switched "off"

- 6.6.7.3. On M1 and N1 vehicles less than 6 m in length, with an arrangement complying with paragraph 6.5.5.2. above, the amber side-marker lamps, when mounted, shall also flash at the same frequency (in phase) with the direction-indicator lamps.

6.6.8. **Tell-tale**

Flashing circuit-closed tell-tale mandatory.

6.6.9. **Other requirements**

As specified in paragraph 6.5.9. If a power-driven vehicle is equipped to draw a trailer the hazard warning signal control shall also be capable of bringing the direction-indicator lamps on the trailer into action. The hazard warning signal shall be able to function even if the device which starts or stops the engine is in a position which makes it impossible to start the engine.

6.7. **Stop Lamp**

6.7.1. **Presence**

Devices of S1 or S2 categories: Mandatory on all L7, M and N categories of vehicles.

Devices of S3 or S4 category: mandatory on M1 and N1 categories of vehicles with full metal body, except for chassis-cabs and those N1 category vehicles with open cargo space; Not applicable for quadricycles optional on other categories of vehicles.

6.7.2. **Number**

Two S1 or S2 category devices and one S3 or S4 category as applicable

- 6.7.2.1. Except in the case where a category S3 or S4 device is installed, two optional category S1 or S2 devices may be installed on vehicles in categories M2, M3, N2, N3, T2, T3, and T4.

- 6.7.2.2. Only, when the median longitudinal plane of the vehicle is not located on a fixed body panel but separates one or two movable parts of the vehicle (e.g. Doors), and lacks sufficient space to install a single device of the S3 or S4 category on the median longitudinal plane above such movable parts, either:

Two devices of the S3 or S4 category type "D" may be installed; or
One device of the S3 or S4 category may be installed offset to the left or to the right of the median longitudinal plane, or

An interdependent lamp system of category S3 or S4 may be installed.

6.7.3. **Arrangement**

No special requirement.

6.7.4. **Position**

6.7.4.1. **In width:**

For L7, M1 and N1 category vehicles:

For S1 or S2 categories devices that point on the apparent surface in the direction of the reference axis which is farthest from the vehicle's median longitudinal plane shall not be more than 400 mm from the extreme outer edge of the vehicle;

For the distance in between the inner edges of the apparent surfaces in the direction of the reference axes there is no special requirement.

For all other categories of vehicles:

For S1 or S2 categories devices the distance in between the inner edges of the apparent surfaces in the direction of the reference axes shall be not less than 600 mm. This distance may be reduced to 400 mm if the overall width of the vehicle is less than 1,300 mm.

For S3 or S4 category devices: the center of reference shall be situated on the median longitudinal plane of the vehicle. However, in the case where the two devices of the S3 or S4 category are installed, according to paragraph 6.7.2., they shall be positioned as close as possible to the median longitudinal plane, one on each side of this plane.

In the case where one S3 or S4 category lamp offset from the median longitudinal plane is permitted according to paragraph 6.7.2., this offset shall not exceed 150 mm from the median longitudinal plane to the centre of reference of the lamp.

6.7.4.2. **Height:**

6.7.4.2.1. **For S1 or S2 categories devices:**

Above the ground, not less than 350 mm nor more than 1,500 mm (2,100 mm if the shape of the bodywork makes it impossible to keep within 1,500 mm and if the optional lamps are not installed).

If the optional lamps are installed, they shall be positioned at a height compatible with the requirements of the width and the symmetry of the lamps, and at a vertical distance as large as the shape of the bodywork makes it possible, but not less than 600 mm above the mandatory lamps.

6.7.4.2.2. **For S3 or S4 categories devices:**

The horizontal plane tangential to the lower edge of the apparent surface shall: (a) either not be more than 150 mm below the horizontal plane tangential to the lower edge of the exposed surface of the glass or glazing of the rear window, or (b) not be less than 850 mm above the ground.

However, the horizontal plane tangential to the lower edge of the apparent surface of a S3 or S4 category device shall be above the horizontal plane tangential to the upper edge of the apparent surface of S1 or S2 categories devices.

- 6.7.4.3. **In length:**
- 6.7.4.4. For S1 or S2 categories devices: at the rear of the vehicle.
- 6.7.4.5. For S3 or S4 categories devices: no special requirement.
- 6.7.5. **Geometric visibility**
- Horizontal angle:**
- For S1 or S2 categories devices: 45° to the left and to the right of the longitudinal axis of the vehicle;
- For S3 or S4 categories devices: 10° to the left and to the right of the longitudinal axis of the vehicle.
- Vertical angle:**
- For S1 or S2 categories devices: 15° above and below the horizontal. However, the vertical angle below the horizontal may be reduced to 5°, if the height of the lamp is less than 750 mm. The vertical angle above the horizontal may be reduced to 5° in the case of optional lamps not less than 2,100 mm above the ground;
- For S3 or S4 categories devices: 10° above and 5° below the horizontal.
- 6.7.6. **Orientation**
- Towards the rear of the vehicle.
- 6.7.7. **Electrical connections**
- These shall light up when the service brake is applied. The stop lamps need not function if the device which starts and/or stops the engine is in a position which makes it impossible for the engine to operate. The stop lamps may be activated by the application of a retarded or a similar device.
- 6.7.8. **Tell-tale**
- Tell-tale optional; where fitted, this tell-tale shall be an operating tell-tale consisting of a non-flashing warning light which comes on in the event of the malfunctioning of the stop lamps.
- 6.7.9. **Other requirements**
- 6.7.9.1. The S3 or S4 category device may not be reciprocally incorporated with any other lamp.
- 6.7.9.2. The S3 or S4 category device may be installed outside or inside the vehicle.
- 6.7.9.2.1. In the case where it is installed inside the vehicle:
- The light emitted shall not cause discomfort to the driver through the devices for indirect vision and/or other surfaces of the vehicle (i.e. rear window).
- 6.8. **Rear registration plate lamp**
- 6.8.1. **Presence**
- Mandatory.

- 6.8.2. The number, arrangement, position, geometric visibility and orientation of the device shall be such that the area of registration plate shall be adequately illuminated.
- 6.8.3. Electrical connections
In accordance with paragraph 5.11.
- 6.8.4. Tell-tale
Tell-tale optional. If it exists, its function shall be carried out by the tell-tale required for the front and rear position lamps.
- 6.8.5. Other requirements
When the rear registration plate lamp is combined with the rear position lamp, reciprocally incorporated in the stop lamp or in the rear fog lamp, the photometric characteristics of the rear registration plate lamp may be modified during the illumination of the stop lamp or the rear fog lamp.
- 6.9. **Front position lamp**
- 6.9.1. **Presence**
Mandatory on all motor vehicles.
Mandatory on trailers over 1,600 mm wide.
Optional on trailers which are not more than 1,600 mm wide.
- 6.9.2. **Number**
Two.
- 6.9.3. **Arrangement**
No special requirement.
- 6.9.4. **Position**
- 6.9.4.1. **Width:** That point on the apparent surface in the direction of the reference axis which is farthest from the vehicle's median longitudinal plane shall not be more than 400 mm from the extreme outer edge of the vehicle.

In the case of a trailer, that point on the apparent surface in the direction of the reference axis which is farthest from the median longitudinal plane shall not be more than 150 mm from the extreme outer edge of the vehicle.

The distance between the inner edges of the two apparent surfaces in the direction of the reference axes shall:

For L7, M1 and N1 category vehicles: No special requirement;

For all other categories of vehicles: Not less than 600 mm. This distance may be reduced to 400 mm where the overall width of the vehicle is less than 1,300 mm.
- 6.9.4.2. **Height:** Above the ground, not less than 250 mm nor more than 1,500 mm (2,100 mm for T1 and T2 categories of vehicles, or if for any other categories of vehicles the shape of the bodywork makes it impossible to keep within 1,500 mm).

- 6.9.4.3. **Length:** no individual specification.
- 6.9.4.4. Where the front position lamp and another lamp are reciprocally incorporated, the apparent surface in the direction of the reference axis of the other lamp shall be used to verify compliance with the positioning requirements (paragraphs 6.9.4.1. to 6.9.4.3.).

6.9.5. **Geometric visibility**

- 6.9.5.1. **Horizontal angle** for the two position lamps: 45° inwards and 80° outwards.

For L7, M1 and N1 category vehicles where the lower edge of the apparent surface of the lamps is less than 750 mm above the ground, the value of 45° inward may be reduced to 20° under the horizontal plane containing the reference axis of this lamp.

In the case of trailers, the angle inwards may be reduced to 5°.

Vertical angle: 15° above and below the horizontal. The vertical angle below the horizontal may be reduced to 5° in the case of lamps less than 750 mm above the ground.

- 6.9.5.2. For M1 and N1 category vehicles, as an alternative to paragraph 6.9.5.1., at the discretion of the manufacturer or his duly accredited representative, and only if a front side-marker lamp is installed on the vehicle.

Horizontal angle: 45° outwards to 45° inwards.

Where the lower edge of the apparent surface of the lamps is less than 750 mm above the ground, the value of 45° inward may be reduced to 20° under the horizontal plane containing the reference axis of this lamp.

Vertical angle: 15° above and below the horizontal. The vertical angle below the horizontal may be reduced to 5° if the lamps are less than 750 mm above the ground.

To be considered visible, the lamp shall provide an unobstructed view of the apparent surface of at least 12.5 cm². The illuminating surface area of any retro-reflector that does not transmit light shall be excluded.

6.9.6. **Orientation**

Forwards.

6.9.7. **Electrical connections**

In accordance with paragraph 5.11.

However, if a front position lamp is reciprocally incorporated with a direction-indicator the electrical connection of the front position lamp on the relevant side of the vehicle or the reciprocally incorporated part of it may be such that it is switched off during the entire period (both ON and OFF cycle) of activation of the direction-indicator lamp.

- 6.9.8. **Tell-tale**
Circuit-closed tell-tale mandatory. This tell-tale shall be non-flashing and shall not be required if the instrument panel lighting can only be turned on simultaneously with the front position lamps.
This requirement does not apply when light signaling system operates according to paragraph 6.2.7.6.2.
- 6.9.9. **Other requirements**
- 6.9.9.1. If one or more infrared radiation generator(s) is (are) installed inside the front position lamp, it (they) is (are) allowed to be activated only when the headlamp on the same side of the vehicle is switched on and the vehicle is in forward motion. In the event that the front position lamp or the headlamp on the same side fails, the infrared radiation generator(s) shall be automatically switched off.
- 6.9.9.2. In case an AFS providing a bending mode is installed, the front position lamp may be swiveled together with a lighting unit to which it is reciprocally incorporated.
- 6.10. **Rear position lamp**
- 6.10.1. **Presence**
Devices of R or R1 or R2 categories: Mandatory.
- 6.10.2. **Number**
Two.
- 6.10.2.1. Except the case where end-outline marker lamps are installed, two optional position lamps may be installed on all vehicles in categories M2, M3, N2, N3, T2, T3, and T4.
- 6.10.3. **Arrangement**
No special requirement.
- 6.10.4. **Position**
- 6.10.4.1. **Width:** that point on the apparent surface in the direction of the reference axis which is farthest from the vehicle's median longitudinal plane shall not be more than 400 mm from the extreme outer edge of the vehicle. This condition shall not apply to the optional rear lamps.
The distance between the inner edges of the two apparent surfaces in the direction of the reference axes shall:
For L7, M1 and N1 category vehicles: have no special requirement;
For all other categories of vehicles: be not less than 600 mm. This distance may be reduced to 400 mm where the overall width of the vehicle is less than 1,300 mm.
- 6.10.4.2 **Height:** above the ground, not less than 350 mm nor more than 1,500 mm (2,100 mm if the shape of the bodywork makes it impossible to keep within 1,500 mm and if the optional lamps are not installed). If the optional lamps are installed, they shall be placed at a height compatible with the applicable requirements of paragraph 6.10.4.1., the symmetry of the lamps, and at a vertical distance as large as the shape of the bodywork makes it possible, but not less than 600 mm above the mandatory lamps.

- 6.10.4.3 **Length:** The rear of the vehicle.
- 6.10.5. **Geometric visibility**
- 6.10.5.1. **Horizontal angle:** 45° inwards and 80° outwards.
Vertical angle: 15° above and below the horizontal. The vertical angle below the horizontal may be reduced to 5° in the case of lamps less than 750 mm above the ground. The vertical angle above the horizontal may be reduced to 5° in the case of optional lamps not less than 2,100 mm above the ground.
- 6.10.5.2. For M1 and N1 category vehicles, as an alternative to paragraph 6.10.5.1., at the discretion of the manufacturer or his duly accredited representative, and only if a rear side-marker lamp is installed on the vehicle.
Horizontal angle: 45° outwards to 45° inwards.
Vertical angle: 15° above and below the horizontal. The vertical angle below the horizontal may be reduced to 5° if the lamps are less than 750 mm above the ground.
 To be considered visible, the lamp shall provide an unobstructed view of the apparent surface of at least 12.5 square centimeters. The illuminating surface area of any retro- reflector that does not transmit light shall be excluded.
- 6.10.6. **Orientation**
 Rearwards.
- 6.10.7. **Electrical connections**
 In accordance with paragraph 5.11.
 However, if a rear position lamp is reciprocally incorporated with a direction-indicator, the electrical connection of the rear position lamp on the relevant side of the vehicle or the reciprocally incorporated part of it may be such that it is switched OFF during the entire period (both ON and OFF cycle) of activation of the direction-indicator lamp.
- 6.10.8. **Tell-tale**
 Circuit-closed tell-tale mandatory. It shall be combined with that of the front position lamps.
 This requirement does not apply when light signaling system operates according to paragraph 6.2.7.6.2.
- 6.10.9. **Other requirements**
 None.
- 6.11. **Rear fog lamp**
- 6.11.1. **Presence**
 Devices of F or F1 or F2 categories: Optional.
- 6.11.2. **Number**
 One or two.
- 6.11.3. **Arrangement**
 No special requirement.

- 6.11.4. **Position**
- 6.11.4.1. In **width**: if there is only one rear fog-lamp, it shall be on the opposite side of the median longitudinal plane of the vehicle to the direction of traffic prescribed in the country of registration, the center of reference may also be situated on the median longitudinal plane of the vehicle.
- 6.11.4.2. **Height**: not less than 250 mm nor more than 1,000 mm above the ground. For rear fog lamps grouped with any rear lamp or for category N3G (off-road) vehicles, the maximum height may be increased to 1,200 mm.
- 6.11.4.3. **Length**: At the rear of the vehicle.
- 6.11.5. **Geometric visibility**
Defined by angles α and β as specified in paragraph 2.13.:
 $\alpha = 5^\circ$ upwards and 5° downwards;
 $\beta = 25^\circ$ to right and to left.
- 6.11.6. **Orientation**
Rearwards.
- 6.11.7. **Electrical connections**
These shall be such that:
- 6.11.7.1. The rear fog-lamp(s) cannot be switched on unless the main beams, dipped-beams or front fog-lamps are lit;
- 6.11.7.2. The rear fog-lamp(s) can be switched off independently of any other lamp;
- 6.11.7.3. Either of the following applies:
- 6.11.7.3.1. The rear fog lamp(s) may continue to operate until the position lamps are switched off, and the rear fog lamp(s) shall then remain off until deliberately switched on again;
- 6.11.7.3.2. A warning, at least audible, additional to the mandatory tell-tale (paragraph 6.11.8.) shall be given if the ignition is switched off or the ignition key is withdrawn and the driver's door is opened, whether the lamps in (paragraph 6.11.7.1.) are on or off, whilst the rear fog lamp switch is in the "on" position.
- 6.11.7.4. Except as provided in paragraphs 6.11.7.1., 6.11.7.3. and 6.11.7.5., the operation of the rear fog lamp(s) shall not be affected by switching on or off any other lamps.
- 6.11.7.5. The rear fog lamp(s) of a drawing motor vehicle may be automatically switched off while a trailer is connected and the rear fog lamp(s) of the trailer is (are) activated.
- 6.11.8. **Tell-tale**
Circuit-closed tell-tale mandatory. An independent non-flashing warning light.
- 6.11.9. **Other requirements**
In all cases, the distance between the rear fog-lamp and each stop-lamp shall be greater than 100 mm.

- 6.12. **Parking lamp**
- 6.12.1. **Presence**
On motor vehicles not exceeding 6 m in length and not exceeding 2 m in width, optional. On all other vehicles, prohibited.
- 6.12.2. **Number**
According to the arrangement.
- 6.12.3. **Arrangement**
Either two lamps at the front or two lamps at the rear, or one lamp on each side.
- 6.12.4. **Position**
- 6.12.4.1. **Width:** that point on the apparent surface in the direction of the reference axis which is farthest from the vehicle's median longitudinal plane shall not be more than 400 mm from the extreme outer edge of the vehicle.
Furthermore, if there are two lamps, they shall be on the sides of the vehicle.
- 6.12.4.2. **Height:**
For L7, M1 and N1 category vehicles: no special requirement;
For all other categories of vehicles: above the ground, not less than 350 mm nor more than 1,500 mm (2,100 mm if the shape of the bodywork makes it impossible to keep within 1,500 mm).
- 6.12.4.3. **Length:** no special requirement.
- 6.12.5. **Geometric visibility**
Horizontal angle: 45° outwards, forwards and rearwards.
Vertical angle: 15° above and below the horizontal. The vertical angle below the horizontal may be reduced to 5°, however, if the height of the lamp is less than 750 mm.
- 6.12.6. **Orientation**
Such that the lamps meet the requirements for visibility forwards and rearwards.
- 6.12.7. **Electrical connections**
The connection shall allow the parking lamp(s) on the same side of the vehicle to be lit independently of any other lamps.
The parking lamp(s) and, if applicable, the front and rear position lamps according to paragraph 6.12.9. below, shall be able to operate even if the device which starts the engine is in a position which makes it impossible for the engine to operate. A device which automatically deactivates these lamps as a function of time is prohibited.
- 6.12.8. **Tell-tale**
Circuit-closed tell-tale optional. If there is one, it shall not be possible to confuse it with the tell-tale for the front and rear position lamps.

6.12.9. **Other requirements**

The functioning of this lamp may also be performed by simultaneously switching on the front and rear position lamps on the same side of the vehicle. In this case, lamps that meet the requirements of front or rear position lamps are deemed to meet the requirements of parking lamps.

6.13. **End-outline marker lamp**

6.13.1. **Presence**

Devices of A or AM categories (visible from the front), and devices of R, R1, R2, RM1 or RM2 Categories (visible from the rear):

Mandatory on vehicles exceeding 2.10 m in width. Optional on vehicles between 1.80 and 2.10 m in width. On chassis-cabs the rear end-outline marker lamps are optional.

6.13.2. **Number**

Two visible from the front and two visible from the rear. Optional: additional lamps may be fitted as follows:

- (a) Two visible from the front;
- (b) Two visible from the rear.

6.13.3. **Arrangement**

No special requirement.

6.13.4. **Position**

6.13.4.1 **Width:**

Front and rear: as close as possible to the extreme outer edge of the vehicle. This condition is deemed to have been met when the point on the apparent surface in the direction of the reference axis which is farthest from the vehicle's median longitudinal plane is not more than 400 mm from the extreme outer edge of the vehicle.

6.13.4.2. **Height:**

Front:

Motor vehicles - the horizontal plane tangential to the upper edge of the apparent surface in the direction of the reference axis of the device shall not be lower than the horizontal plane tangential to the upper edge of the transparent zone of the wind-screen.

Trailers and semi-trailers - at the maximum height compatible with the requirements relating to the width, design and operational requirements of the vehicle and to the symmetry of the lamps.

Rear:

At the maximum height compatible with the requirements relating to the width, design and operational requirements of the vehicle and to the symmetry of the lamps.

Both optional and mandatory (as applicable) lamps to be fitted as far separated in height as practicable and compatible with design/operational requirements of the vehicle and symmetry of the lamps.

- 6.13.4.3. **Length**, no special requirement.
The additional lamps visible from the front, as specified in paragraph 6.13.2 (a)., as close as practicable to the rear. However, the distance between the additional lamps and the rear of the vehicle shall not exceed 400 mm.
- 6.13.5. **Geometric visibility**
- 6.13.5.1 **Horizontal angle:** 80° outwards.
- 6.13.5.2 **Vertical angle:** 5° above and 20° below the horizontal.
“This requirement does not apply to vehicles where it is not possible, for practical reasons including limitation of the shape, structure, design or operational requirements, to meet Geometric visibility for the downward angle.
Provided subject vehicle comply with rear conspicuity marking requirement showing width of vehicle as per AIS-090.”
- 6.13.6. **Orientation**
There shall be such that the lamps meet the requirements for visibility forwards and rearwards.
- 6.13.7. **Electrical connections**
Same as paragraph 5.11.
- 6.13.8. **Tell-tale**
Tell-tale optional. If it exists, its function shall be carried out by the tell-tale required for the front and rear position lamps.
- 6.13.9. **Other requirements**
Provided that all other requirements are met, the mandatory or optional lamps, visible from the front and the mandatory or optional lamps visible from the rear on the same side of the vehicle may be combined into one device.
Two of the lamps visible from the rear may be grouped, combined or reciprocally incorporated in accordance with paragraph 5.7.
The position of an end-outline marker lamp in relation to corresponding position lamp shall be such that the distance between the projections on a transverse vertical plane of the points nearest to one another on the apparent surfaces in the direction of the respective reference axes of the two lamps considered is not less than 200 mm.
- 6.14. **Rear retro-reflector, non-triangular**
- 6.14.1. **Presence**
Mandatory on all motor vehicles of L7, M and N category.
Provided that they may be grouped together with the other rear light-signalling devices, optional on trailers.

6.14.2. **Number**

Two, the performances of which shall conform to the requirements concerning Class IA or IB retro-reflectors as per AIS-057 Additional retro-reflecting devices and materials (including two retro-reflectors not complying with paragraph 6.14.4. below), are permitted provided they do not impair the effectiveness of the mandatory lighting and light-signalling devices.

6.14.3. **Arrangement**

No special requirement.

6.14.4. **Position**6.14.4.1. **Width:** that point on the illuminating surface which is farthest from the vehicle's median longitudinal plane shall not be more than 400 mm from the extreme outer edge of the vehicle.

The distance between the inner edges of the two apparent surfaces in the direction of the reference axes shall:

For L7, M1 and N1 category vehicles: have no special requirement;

For all other categories of vehicles: be not less than 600 mm. This distance may be reduced to 400 mm where the overall width of the vehicle is less than 1,300 mm.

6.14.4.2. **Height:** Above the ground, not less than 250 mm nor more than 900 mm (not more than 1,200 mm if grouped with any rear lamp(s) 1,500 mm if the shape of the bodywork makes it impossible to keep within 900 mm or 1200 mm respectively).6.14.4.3. **Length:** at the rear of the vehicle.6.14.5. **Geometric visibility**

Horizontal angle: 30° inwards and outwards.

Vertical angle: 10° above and below horizontal. The vertical angle below the horizontal may be reduced to 5° in the case of a retro-reflector less than 750 mm above the ground.

6.14.6. **Orientation**

Rearwards.

6.14.7. **Other requirements**

The illuminating surface of the retro-reflector may have parts in common with the apparent surface of any other lamp situated at the rear.

6.15. **Rear retro-reflector, triangular**6.15.1 **Presence**

Mandatory on trailers.

Prohibited on motor vehicles of categories L7, M & N

6.15.2. **Number**

Two, the performances of which shall conform to the requirements concerning Class IIIA or Class IIIB retro-reflectors in Standard AIS-057 Additional retro-reflecting devices and materials (including two retro-reflectors not complying with paragraph 6.15.4. below), are permitted provided they do not impair the effectiveness of the mandatory lighting and light-signalling devices.

6.15.3. **Arrangement**

The apex of the triangle shall be directed upwards.

6.15.4. **Position**6.15.4.1. **Width:** that point on the illuminating surface which is farthest from the vehicle's median longitudinal plane shall not be more than 400 mm from the extreme outer edge of the vehicle.

The inner edges of the retro-reflectors shall not be less than 600 mm apart. This distance may be reduced to 400 mm if the overall width of the vehicle is less than 1,300 mm.

6.15.4.2. **Height:** Above the ground, not less than 250 mm nor more than 900 mm (not more than 1,200 mm if grouped with any rear lamp(s), 1,500 mm if the shape of the bodywork makes it impossible to keep within 900 mm or 1,200 mm respectively).6.15.4.3. **Length:** at the rear of the vehicle.6.15.5. **Geometric visibility**

Horizontal angle: 30° inwards and outwards.

Vertical angle: 15° above and below the horizontal. The vertical angle below the horizontal may be reduced to 5° in the case of a retro-reflector less than 750 mm above the ground.

6.15.6. **Orientation**

Rearwards.

6.15.7. **Other requirements**

The illuminating surface of the retro-reflector may have parts in common with the apparent surface of any other lamp situated at the rear.

6.16. **Front retro-reflector, non-triangular**6.16.1. **Presence**

Mandatory on trailers and goods vehicles.

Mandatory on motor vehicles having all forward facing lamps with reflectors concealable. Optional on other motor vehicles.

6.16.2. **Number**

Two, the performances of which shall conform to the requirements concerning Class IA or IB retro-reflectors as per AIS 057. Additional retro-reflecting devices and materials (including two retro-reflectors not complying with paragraph 6.16.4. below), are permitted provided

they do not impair the effectiveness of the mandatory lighting and light-signalling devices.

6.16.3. **Arrangement**

No special requirement.

6.16.4. **Position**

6.16.4.1. **Width:** that point on the illuminating surface which is farthest from the vehicle's median longitudinal plane shall not be more than 400 mm from the extreme outer edge of the vehicle.

In the case of a trailer, the point of the illuminating surface which is farthest from the vehicle's median longitudinal plane shall not be farther than 150 mm from the extreme outer edge of the vehicle.

The distance between the inner edges of the two apparent surfaces in the direction of the reference axes shall:

For M1 and N1 category vehicles: have no special requirement;

For all other categories of vehicles: be not less than 600 mm. This distance may be reduced to 400 mm where the overall width of the vehicle is less than 1,300 mm.

6.16.4.2. **Height:** above the ground, not less than 250 mm nor more than 900 mm (1,500 mm if the shape of the bodywork makes it impossible to keep within 900 mm).

6.16.4.3 **Length:** at the front of the vehicle.

6.16.5. **Geometric visibility**

Horizontal angle, 30° inwards and outwards. In the case of trailers, the angle inwards may be reduced to 10°. If because of the construction of the trailers this angle cannot be met by the mandatory retro-reflectors, then additional (supplementary) retro-reflectors shall be fitted, without the width limitation (paragraph 6.16.4.1.), which shall, in conjunction with the mandatory retro-reflectors, give the necessary visibility angle.

Vertical angle: 10° above and below the horizontal. The vertical angle below the horizontal may be reduced to 5° in the case of a retro-reflector less than 750 mm above the ground.

6.16.6. **Orientation**

Towards the front.

6.16.7. **Other requirements**

The illuminating surface of the retro-reflector may have parts in common with the apparent surface of any other lamp situated at the front.

6.17. **Side retro-reflector, non-triangular**

6.17.1. **Presence**

Mandatory: On all motor vehicles the length of which exceeds 6 m on all trailers.

Optional: On motor vehicles the length of which does not exceed 6m.

6.17.2. **Number**

Such that the requirements for longitudinal positioning are complied with. The performances of these devices shall conform to the requirements concerning Class IA or IB retro-reflectors as per AIS-057. Additional retro-reflecting devices and materials (including two retro-reflectors not complying with paragraph 6.17.4. below), are permitted provided they do not impair the effectiveness of the mandatory lighting and light-signalling devices.

6.17.3. **Arrangement**

No special requirement.

6.17.4. **Position**6.17.4.1. **Width:** no special requirement.6.17.4.2. **Height:** Above the ground, not less than 250 mm nor more than 900 mm (not more than 1,200 mm if grouped with any lamp(s), 1,500 mm if the shape of the bodywork makes it impossible to keep within 900 mm or 1,200 mm respectively or if the presence of the device is not mandatory according to paragraph 6.17.1.).6.17.4.3. **Length:** At least one side retro-reflector shall be fitted to the middle third of the vehicle, the foremost side retro-reflector being not further than 3 m from the front.

The distance between two adjacent side retro-reflectors shall not exceed 3 m. This does not, however, apply to L7-M, M1 and N1 category vehicles.

If the structure, design or the operational use of the vehicle makes it impossible to comply with such a requirement, this distance may be increased to 4 m. The distance between the rearmost side retro-reflector and the rear of the vehicle shall not exceed 1 m. However, for motor vehicles the length of which does not exceed 6 m, it is sufficient to have one side retro-reflector fitted within the first third and/or one within the last third of the vehicle length.

However, for motor vehicles the length of which does not exceed 6 m, it is sufficient to have one side retro-reflector fitted within the first third and/or one within the last third of the vehicle length. For M1 vehicles the length of which exceeds 6 m but does not exceed 7 m it is sufficient to have one side retro-reflector fitted not further than 3 m from the front and one within the last third of the vehicle length.

6.17.5. **Geometric visibility**

Horizontal angle: 45° to the front and to the rear.

Vertical angle: 10° above and below the horizontal. The vertical angle below the horizontal may be reduced to 5° in the case of a retro-reflector less than 750 mm above the ground.

6.17.6. **Orientation**

Towards the side.

6.17.7. **Other requirements**

The illuminating surface of the side retro-reflector may have parts in common with the apparent surface of any other side lamp.

6.18. **Side marker lamps**6.18.1. **Presence**

Mandatory: On all vehicles the length of which exceeds 6 m, except for chassis-cabs.

The SM1 type of side-marker lamp shall be used on all categories of vehicles; however,

The SM2 type of side-marker lamps may be used on the M1 category of vehicles.

In addition, on M1 and N1 category vehicles less than 6 m in length, side-marker lamps shall be used, if they supplement the reduced geometric visibility requirements of front position lamps conforming to paragraph 6.9.5.2. and rear position lamps conforming to paragraph 6.10.5.2.

Optional: On all other vehicles.

The SM1 or SM2 types of side-marker lamps may be used.

6.18.2. **Minimum number per side**

This shall be such that the rules for longitudinal positioning are complied with.

6.18.3. **Arrangement**

No individual specifications.

6.18.4. **Position**6.18.4.1. **Width:** No individual specifications.6.18.4.2. **Height:** Above the ground, not less than 250 mm nor more than 1,500 mm (2,100 mm if the shape of the bodywork makes it impossible to keep within 1,500 mm).6.18.4.3. **Length:** at least one side-marker lamp shall be fitted to the middle third of the vehicle, the foremost side-marker lamp being not further than 3 m from the front. The distance between two adjacent side-marker lamps shall not exceed 3 m. If the structure, design or the operational use of the vehicle make it impossible to comply with such a requirement, this distance may be increased to 4 m.

The distance between the rearmost side-marker lamp and the rear of the vehicle shall not exceed 1 m.

However, for vehicles the length of which does not exceed 6 m and for chassis-cabs it is sufficient to have one side-marker lamp fitted within the first third and/or within the last third of the vehicle length. For M1 vehicles the length of which exceeds 6 m but does not exceed 7 m it is sufficient to have one side-marker lamp fitted not further than 3 m from the front and one within the last third of the vehicle length.

6.18.5. **Geometric visibility**

Horizontal angle: 45° to the front and to the rear; however, for vehicles on which the installation of the side-marker lamps is optional this value can be reduced to 30°.

If the vehicle is equipped with side-marker lamps used to supplement the reduced geometric visibility of front and rear direction-indicator lamps conforming to paragraph 6.5.5.2. and/or position lamps conforming to paragraphs 6.9.5.2. and 6.10.5.2., the angles are 45° towards the front and rear ends of the vehicle and 30° towards the Centre of the vehicle (see the figure in paragraph 6.5.5.2. above).

Vertical angle: 10° above and below the horizontal. The vertical angle below the horizontal may be reduced to 5° in the case of a side-marker lamp less than 750 mm above the ground.

6.18.6. **Orientation**

Towards the side.

6.18.7. **Electrical connection**

On M1 and N1 category vehicles less than 6 m in length amber side-marker lamps may be wired to flash, provided that this flashing is in phase and at the same frequency with the direction-indicator lamps at the same side of the vehicle.

For all other categories of vehicles: no individual specification.

6.18.8. **Tell-tale**

Tell-tale optional. If it exists its function shall be carried out by the tell-tale required for the front and rear position lamps.

6.18.9. **Other requirements**

When the rearmost side-marker lamp is combined with the rear position lamp reciprocally incorporated with the rear fog-lamp or stop lamp, the photometric characteristics of the side-marker lamp may be modified during the illumination of the rear fog lamp or stop lamp.

Rear side-marker lamps shall be amber if they flash with the rear direction-indicator lamp.

6.19. DAYTIME RUNNING LAMP6.19.1. **Presence**

Optional on motor vehicles. Prohibited on trailers.

6.19.2. **Number**

Two.

6.19.3. **Arrangement**

No special requirement.

6.19.4. **Position**

- 6.19.4.1. **Width**
The distance between the inner edges of the apparent surfaces in the direction of the reference axes shall not be less than 600 mm.
This distance may be reduced to 400 mm where the overall width of the vehicle is less than 1,300 mm.
- 6.19.4.2. **Height:** above the ground not less than 250 mm nor more than 1,500 mm.
- 6.19.4.3. **Length:** at the front of the vehicle. This requirement shall be deemed to be satisfied if the light emitted does not cause discomfort to the driver either directly or indirectly through the devices for indirect vision and/or other reflecting surfaces of the vehicle.
- 6.19.5. **Geometric visibility**
Horizontal: outwards 20° and inwards 20°. Vertical: upwards 10° and downwards 10°.
- 6.19.6. **Orientation**
Towards the front.
- 6.19.7. **Electrical connections**
- 6.19.7.1. If Installed the daytime running lamps shall be switched ON automatically when the device which starts and/or stops the engine (propulsion system) is set in a position which makes it possible for the engine (propulsion system) to operate. However, the daytime running lamps may remain OFF while the following conditions exist:
- 6.19.7.1.1. The automatic transmission control is in the park position; or
- 6.19.7.1.2. The parking brake is in the applied position; or
- 6.19.7.1.3. Prior to the vehicle being set in motion for the first time after each manual activation of the propulsion system.
- 6.19.7.3. The daytime running lamp shall switch OFF automatically when the device which starts and/or stops the engine (propulsion system) is set in a position which makes it impossible for the engine (propulsion system) to operate or the front fog lamps or headlamps are switched ON, except when the latter are used to give intermittent luminous warnings at short intervals.
- 6.19.7.4. The lamps referred to in paragraph 5.11. may be switched ON when the daytime running lamps are switched ON, except if daytime running lamps are operating according to paragraph 6.2.7.6.2., where at least the rear position lamps shall be activated.
- 6.19.7.5. If the distance between the front direction-indicator lamp and the daytime running lamp is equal or less than 40 mm, the electrical connections of the daytime running lamp on the relevant side of the vehicle may be such that either:
- (a) It is switched OFF; or

- (b) Its luminous intensity is reduced during the entire period (both ON and OFF cycle) of activation of a front direction-indicator lamp.
- 6.19.7.6. If a direction-indicator lamp is reciprocally incorporated with a daytime running lamp, the electrical connections of the daytime running lamp on the relevant side of the vehicle shall be such that the daytime running lamp is switched OFF during the entire period (both ON and OFF cycle) of activation of the direction-indicator lamp.
- 6.19.7.7. It may be possible to activate and deactivate the automatic switching ON of daytime running lamps without the use of tools.
- 6.19.8. **Tell-tale**
Closed-circuit tell-tale optional.
- 6.19.9. **Other prescriptions**
No prescription.
- 6.20. **Cornering lamp**
- 6.20.1. **Presence**
Optional on motor vehicles
- 6.20.2. **Number**
Two.
- 6.20.3. **Arrangement**
No special requirement
- 6.20.4. **Position**
- 6.20.4.1. **Width:** One cornering lamp shall be located on each side of the vehicle's median longitudinal plane
- 6.20.4.2. **Length:** Not further than 1,000 mm from the front.
- 6.20.4.3. **Height:** Minimum: Not less than 250 mm above the ground;
Maximum: Not more than 900 mm above the ground.
- However, no point on the apparent surface in the direction of the reference axis shall be higher than the highest point on the apparent surface in the direction of the reference axis of the dipped-beam headlamp.
- 6.20.5. **Geometric visibility**
Defined by angles α and β as specified in paragraph 2.13.
 $\alpha = 10^\circ$ upwards and downwards,
 $\beta = 30^\circ$ to 60° outwards.
- 6.20.6. **Orientation**
Such that the lamps meet the requirements for geometric visibility.
- 6.20.7. **Electrical connections**
The cornering lamps shall be so connected that they cannot be activated unless the main- beam headlamps or the dipped-beam headlamps are switched ON at the same time.

6.20.7.1. The cornering lamp on one side of the vehicle may only be switched ON automatically when the direction-indicators on the same side of the vehicle are switched ON and/or when the steering angle is changed from the straight-ahead position towards the same side of the vehicle.

The cornering lamp shall be switched OFF automatically when the direction-indicator is switched OFF and/or the steering angle has returned in the straight-ahead position.

6.20.7.2. When the reversing lamp is switched ON, both cornering lamps may be switched on simultaneously, independently from the steering wheel or direction-indicator position. If so activated, both cornering lamps shall be switched OFF, either,

(a) When the reversing lamp is switched OFF; or

(b) When the forward speed of the vehicle exceeds 10 km/h.

6.20.8. **Tell-tale**

None.

6.20.9. **Other requirements**

The cornering lamps shall not be activated at vehicle speeds above 40 km/h.

6.21. **Conspicuity marking**

6.21.1. **Presence**

6.21.1.1. Prohibited: on vehicles of categories L7, M1 and T1.

6.21.1.2. Mandatory:

6.21.1.2.1. To the rear:

(i) Full contour marking on following categories using reflective tape of width not less than 50 mm.

(a) N2 with a maximum mass 7.5 tonnes and above and N3 (with the exception of chassis-cabs, incomplete vehicles and tractors for semi-trailers);

(b) T3 and T4 (with the exception of incomplete vehicles).

(ii) Contour marking on Type II and Type III buses of M3 category using reflective tape of width not less than 50 mm.

(iii) Red Reflective tapes for the following categories.

(a) Reflective tape of width not less than 20 mm for N1 category and N2 category with mass above 3.5 tonnes but less than 7.5 tonnes.

(b) Reflective tape of width not less than 50 mm for buses of M2 and M3 categories which are not covered under Clause No 6.21.1.2.1 (ii) above.

- 6.21.1.2.2. To the side:
- 6.21.1.2.2.1. (i) Partial contour marking on following categories using reflective tape of width not less than 50 mm.
- (a) N2 with a maximum mass of 7.5 tonnes and above and N3 (with the exception of chassis-cabs, incomplete vehicles and tractors for semi-trailers).
 - (b) T3 and T4 (with the exception of incomplete vehicles).
- (ii) Reflective tapes of width not less than 50 mm for M3 category.
- 6.21.1.2.3 To the front
- (i) Reflective tape of width not less than 20 mm for N1 category and N2 category with mass above 3.5 tonnes but less than 7.5 tonnes.
 - (ii) Reflective tape of width not less than 50 mm for vehicles of N2 category with maximum mass of 7.5 tonnes and above, N3, M2 and M3.
- 6.21.1.2.4. A line marking may be installed instead of the mandatory contour marking if the shape, structure, design or operational requirements of the vehicle make it impossible to install the mandatory contour marking.
- 6.21.1.2.5. If the exterior surfaces of the bodywork are partially constituted of flexible material, this line marking shall be installed on (a) rigid part(s) of the vehicle. The remaining portion of conspicuity markings may be fitted on the flexible material. However, if the exterior surfaces of the bodywork are fully constituted of flexible material, requirements of paragraph 6.21. shall be met.
- 6.21.1.2.6. In cases where the manufacturer, after verification by the test agency, can prove to the satisfaction of the authority responsible for type approval that it is impossible, due to the operational requirements which may require special shape, structure or design of the vehicle, to comply with the requirements contained in paragraphs 6.21.2. to 6.21.7.5., then partial fulfilment of some of these requirements is acceptable. This is conditional upon a portion of the requirements being met where possible, and the application of conspicuity markings that partially meet requirements maximized on the vehicle structure. This may include fitting of additional brackets or plates containing material compliant with standard AIS-090 where structure is available to ensure clear and uniform signaling compatible with the objective of conspicuity.
- Where partial fulfilment is deemed acceptable, retro-reflective devices like retro-reflectors of class IVA of Standard AIS-057 or brackets containing retro-reflecting material compliant with photometric requirements of Class C of AIS-090 standard may substitute part of the required conspicuity markings. In this case, at least one of these retro reflective devices shall be installed per 1500 mm.
- The necessary information shall be indicated in the technical specification sheet.

- 6.21.1.3. Optional:
 - 6.21.1.3.1. To the rear and to the side:

On all other categories of vehicles, not otherwise specified in paragraphs 6.21.1.1. and 6.21.1.2. above, including the cab of tractor units for semi-trailers and the cab of chassis-cabs.

Partial or full contour marking may be applied instead of mandatory line markings, and full contour marking may be applied instead of mandatory partial contour marking.
 - 6.21.1.3.2. To the front:

Line marking on vehicles of categories T2, T3 and T4.

Partial or full contour marking may not be applied to the front.
- 6.21.2. **Number**

According to the presence.
- 6.21.3. **Arrangement**

The conspicuity markings shall be as close as practicable to horizontal and vertical, compatible with the shape, structure, design and operational requirements of the vehicle; if this is not possible, the full or partial contour markings, when fitted, shall follow as close as practicable the contour of the outer shape of the vehicle.

Furthermore, the conspicuity markings shall be spaced as evenly as possible over the horizontal dimensions of the vehicle such that the total length and/or width of the vehicle can be identified.
- 6.21.4. **Position**
 - 6.21.4.1. **Width**
 - 6.21.4.1.1. The conspicuity marking shall be as close as practicable to the edge of the vehicle.
 - 6.21.4.1.2. In case of Rear reflective tape, the cumulative horizontal length of the elements, as mounted on the vehicle, shall equate to at least 70 per cent of the overall width as per clause 6.21.4.1, excluding any horizontal overlap of individual elements.
 - 6.21.4.1.3. In case of Front reflective tape, the cumulative horizontal length of the conspicuity marking elements, as mounted on the vehicle, shall equate to at least 80 per cent of the overall width as per clause 6.21.4.1, excluding any horizontal overlap of individual elements prove to the satisfaction of the test agency responsible for type approval that it is impossible to achieve the value referred above, the cumulative length may be reduced to 60 per cent and shall be indicated in the technical specification and test report.
 - 6.21.4.2. **Length**
 - 6.21.4.2.1. The conspicuity marking shall be as close as practicable to the ends of the vehicle and reach to within 600 mm of each end of the vehicle

- 6.21.4.2.1.1. For motor vehicles, each end of the vehicle, or in the case of tractors for semi-trailers each end of the cab;

However, an alternative marking mode within 2400 mm from the front end of the motor vehicle is allowed where a series of retro-reflectors of Class IVA of Standard AIS-057 or Class C of AIS-090 is mounted followed by the required conspicuity marking as follows:

- (a) Retro-reflector size minimum 25 cm²;
- (b) One retro-reflector mounted not more than 600 mm from the front end of the vehicle;
- (c) Additional retro-reflectors spaced not more than 600 mm apart;
- (d) The distance between the last retro-reflector and the start of the conspicuity marking shall not exceed 600 mm;

- 6.21.4.2.1.2. For trailers, each end of the vehicle (excluding the drawbar).

6.21.4.2.2. The cumulative horizontal length of the conspicuity marking elements, as mounted on the vehicle, excluding any horizontal overlap of individual elements, shall equate to at least 70 per cent of:

- 6.21.4.2.2.1. For motor vehicles, the length of the vehicle or in the case of tractors for semi-trailers, if fitted, the length of the cab; however, when using the alternative marking mode as per paragraph 6.21.4.2.1.1., the distance beginning within 2,400 mm from the front end of vehicle to its rear end

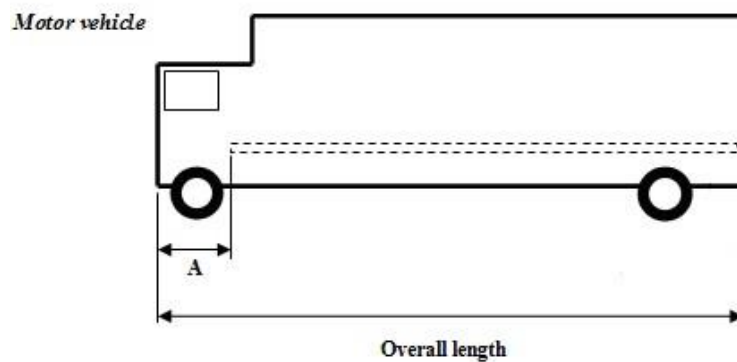

A is the distance between the foremost conspicuity marking and the front end of the vehicle. The maximum value of A is 2400 mm (see paragraph 6.21.4.2.1.1.).

- 6.21.4.2.2.2. For trailers, the overall length of the vehicle (excluding the drawbar).

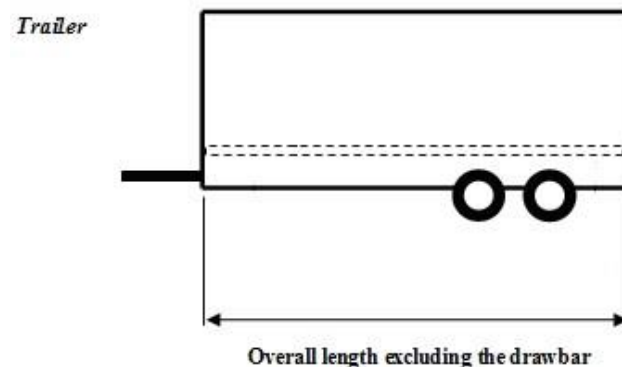

6.21.4.3. **Height**

6.21.4.3.1. Line markings and contour markings lower element(s) as low as practicable within the range:

Minimum: not less than 250 mm above the ground.

Maximum: not more than 1,500 mm above the ground.

However, a maximum mounting height of 2,500 mm may be accepted where the shape, structure, design or operational conditions of the vehicle prevent compliance with the maximum value of 1,500 mm or, if necessary, to fulfil the requirements of paragraphs 6.21.4.1.2., 6.21.4.1.3., 6.21.4.2.2. and 6.21.4.2.3., or the horizontal positioning of the line marking or the lower element(s) of the contour marking.

The necessary justification for installation of conspicuity material higher than 1,500 mm shall be indicated in the technical specification sheet.

6.21.4.3.2. Contour markings upper element(s):

As high as practicable, but within 400 mm of the upper extremity of the vehicle.

6.21.5. **Visibility**

The conspicuity marking shall be considered visible, if at least 70 per cent of the illuminating surface of the installed marking is visible when viewed by an observer positioned at any point within the observation planes defined below:

6.21.5.1. For rear and front conspicuity markings (see Annex F, Figures 1a and 1b) the observation plane is perpendicular to the longitudinal axis of the vehicle situated 25 m from the extreme end of the vehicle and bounded by:

6.21.5.1.1. In height, by two horizontal planes 1 m and 3.0 m respectively above the ground;

6.21.5.1.2. In width, by two vertical planes which form an angle of 4° outwards from the vehicle's median longitudinal plane and which pass through the intersection of the vertical planes parallel to the vehicle's median longitudinal plane delimiting the vehicle's overall width, and the plane perpendicular to the longitudinal axis of the vehicle that delimits the end of the vehicle.

6.21.5.2. For side conspicuity markings (see Annex F, Fig. 2) the observation plane is parallel to the longitudinal median plane of the vehicles situated 25 m from the extreme outer edge of the vehicle and bounded by:

6.21.5.2.1. In height, by two horizontal planes 1.0 m and 1.5 m respectively above the ground;

6.21.5.2.2. In width, by two vertical planes which form an angle of 4° outwards from a plane perpendicular to the vehicle's longitudinal axis and which pass through the intersection of the vertical planes perpendicular to the vehicle's longitudinal axis delimiting the vehicle's overall length and the extreme outer edge of the vehicle.

6.21.6. Orientation

6.21.6.1. To the side:

As close as practicable to being parallel to the median longitudinal plane of the vehicle, compatible with the shape, structure, design and operation requirements of the vehicle; if this is not possible, it shall follow as close as practicable the contour of the outer shape of the vehicle.

6.21.6.2. To the rear and to the front:

As close as practicable to being parallel to the transverse plane of the vehicle, compatible with the shape, structure, design and operation requirements of the vehicle, if this is not possible, it shall follow as close as practicable the contour of the outer shape of the vehicle.

6.21.7. **Other requirements**

6.21.7.1. Conspicuity markings shall be considered continuous if the distance between adjacent elements are as small as possible and do not exceed 50 per cent of the shortest adjacent element length. However, if the manufacturer can prove to the satisfaction of the authority responsible for type approval that it is impossible to respect the value of 50 percent, the distance between adjacent elements may be larger than 50 percent of the shortest adjacent element, and it shall be as small as possible and not exceed 1,000 mm.

6.21.7.2. In the case of a partial contour marking, each upper corner shall be described by two lines at 90°, to each other and each at least 250 mm in length; if this is not possible, the marking shall follow as close as practicable the contour of the outer shape of the vehicle.

6.21.7.3. For the vehicles N2 with a maximum mass 7.5 tonnes and above and N3, the distance between the conspicuity marking fitted to the rear of a vehicle and each mandatory stop lamp should be greater than 200 mm.

6.21.7.4. Where rear marking plates conforming to AIS-089 are installed these may be considered, at the discretion of the manufacturer, as part of the conspicuity marking to the rear, for the purposes of calculating the length of the conspicuity marking and its proximity to the side of the vehicle.

6.21.7.5. The minimum width of the location on the vehicle designated for conspicuity markings shall be more than the width of the conspicuity markings as applicable.

6.21.8 **Rear marking plates**

Rear Marking Plates meeting AIS-089 for vehicle categories notified by Central Motor Vehicle Rules shall be installed as per guidelines given in Annexure K.

6.22. **Adaptive Front Lighting System (AFS)**

Where not otherwise specified below, the requirements for main-beam headlamps (paragraph 6.1.) and for dipped-beam headlamps (paragraph 6.2.) of this standard apply to the relevant part of the AFS.

- 6.22.1. **Presence**
Optional on motor vehicles. Prohibited on trailers.
- 6.22.2. **Number**
One.
- 6.22.3. **Arrangement**
No special requirements.
- 6.22.4. **Position**
The AFS shall, prior to the subsequent test procedures, be set to the neutral state;
- 6.22.4.1. **Width and Height:**
For a given lighting function or mode, the requirements indicated in the paragraphs 6.22.4.1.1. through 6.22.4.1.4. below shall be fulfilled by those lighting units which are energized simultaneously for that lighting function or mode of a function, according to the applicant's description.
All dimensions refer to the nearest edge of the apparent surface(s) observed in the direction of the reference axis, of the lighting unit(s).
- 6.22.4.1.1. Two symmetrically placed lighting units shall be positioned at a height in compliance with the requirements of the relevant paragraphs 6.1.4. and 6.2.4., where "Two symmetrically placed lighting units" shall be understood to be two lighting units, one on each side of the vehicle, positioned such that the (geometric) centers of gravity of their apparent surfaces are at the same height and at the same distance from the vehicle's longitudinal median plane within a tolerance of 50 mm, each; their light emitting surfaces, illuminating surfaces, and light outputs, however, may differ.
- 6.22.4.1.2. Additional lighting units, if any, on either side of the vehicle shall be positioned at a distance not exceeding 140 mm in horizontal direction (E in the figure) and 400 mm in vertical direction above or below (D in the figure) from the nearest lighting unit;
- 6.22.4.1.3. None of the additional lighting units described in paragraph 6.22.4.1.2. above shall be positioned lower than 250 mm (F in the figure) nor higher than indicated in paragraph 6.2.4.2. of this standard (G in the figure) above the ground;
- 6.22.4.1.4. Additionally, in width:
For each mode of the passing-beam lighting:
The outer edge of the apparent surface of at least one lighting unit on each side of the vehicle shall not be more than 400 mm from the extreme outer edge of the vehicle (A in the figure); and, the inner edges of the apparent surfaces in the direction of the reference axes shall be not less than 600 mm apart. This does not apply, however, for M1 and N1 category vehicles; for all other categories of motor vehicles this distance may be reduced to 400 mm where the overall width of the vehicle is less than 1,300 mm.

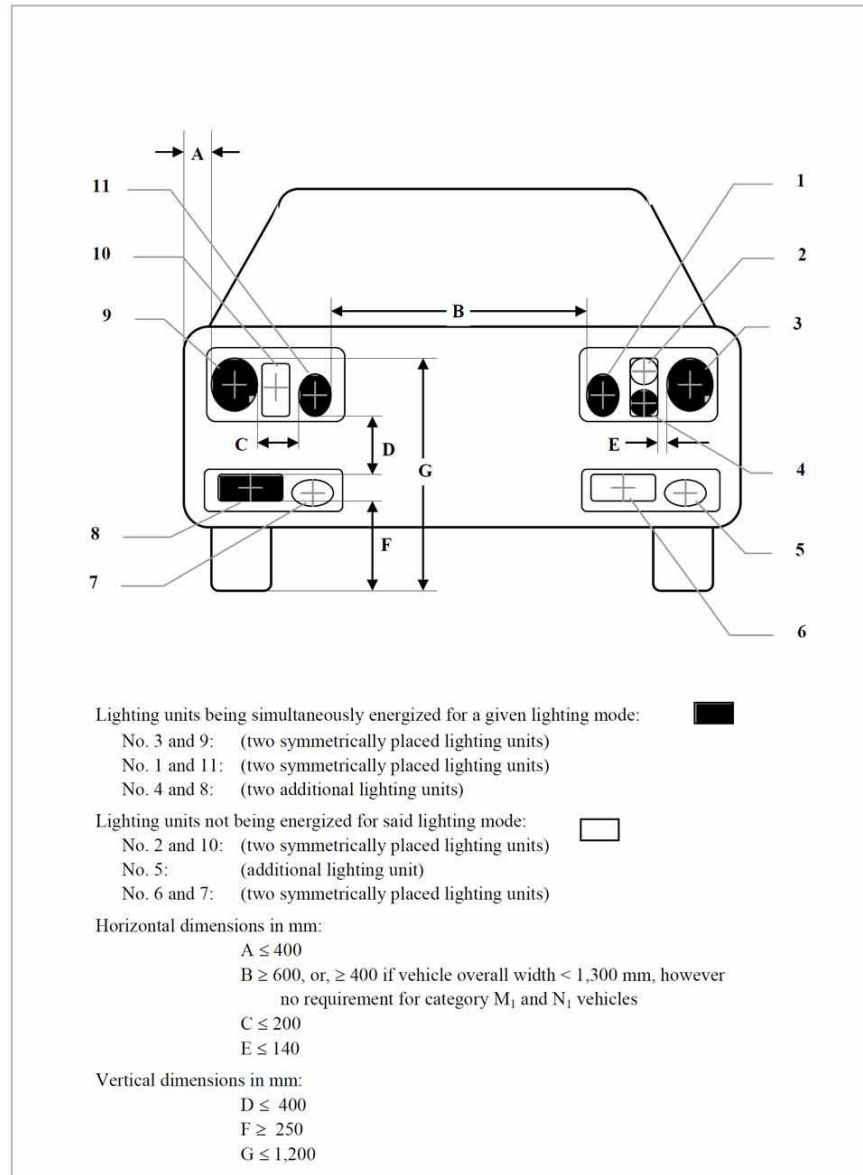

6.22.4.2

Length:

All lighting units of an AFS shall be mounted at the front. This requirement is deemed to be satisfied if the light emitted does not cause discomfort to the driver either directly or indirectly through the devices for indirect vision and/or other reflecting surfaces of the vehicle.

6.22.5.

Geometric visibility

On each side of the vehicle, for each lighting function and mode provided:

The angles of geometric visibility prescribed for the respective lighting functions according to paragraphs 6.1.5. and 6.2.5. of this standard, shall be met by at least one of the lighting units that are simultaneously energized to perform said function and mode(s), according to the description of the applicant. Individual lighting units may be used to comply with the requirements for different angles.

- 6.22.6.1. **Vertical orientation:**
- 6.22.6.1.1. The initial downward inclination of the cut-off of the basic passing-beam to be set in the unladen vehicle state with one person in the driver's seat shall be specified with a precision of 0.1 per cent by the manufacturer and indicated in clearly legible and indelible manner on each vehicle, close to either the front lighting system or the manufacturer's plate,
- Where differing initial downward inclinations are specified by the manufacturer for different lighting units that provide or contribute to the cut-off of the basic passing-beam, these values of downward inclination shall be specified with a precision of 0.1 per cent by the manufacturer and indicated in clearly legible and indelible manner on each vehicle, close to either the relevant lighting units or on the manufacturers plate, in such a way that all the lighting units concerned can be unambiguously identified.
- 6.22.6.1.2. The downward inclination of the horizontal part of the "cut-off" of the basic passing- beam shall remain between the limits indicated in paragraph 6.2.6.1.2. of this Standard under all the static loading conditions of the vehicle of Annex B of this standard; and the initial aiming shall be within the specified values.
- 6.22.6.1.2.1. In case the passing-beam is generated by several beams from different lighting units, the provisions according to paragraph 6.22.6.1.2. above apply to each said beam's "cut-off" (if any), which is designed to project into the angular zone, to standard AIS-127
- 6.22.6.2. Headlamp levelling device
- 6.22.6.2.1. In the case where a headlamp levelling device is necessary to satisfy the requirements of paragraph 6.22.6.1.2., the device shall be automatic.
- 6.22.6.2.2. In the event of a failure of this device, the passing-beam shall not assume a position in which the dip is less than it was at the time when the failure of the device occurred.
- 6.22.6.3. Horizontal orientation:
- For each lighting unit the kink of the elbow of the cut-off line, if any, when projected on the screen, shall coincide with the vertical line through the reference axis of said lighting unit. A tolerance of 0.5 degree to that side which is the side of the traffic direction shall be allowed. Other lighting units shall be adjusted according to the applicant's specification, as defined according to Annex J of standard AIS-127.
- 6.22.6.4. Measuring procedure:
- After adjustment of the initial setting of beam orientation, the vertical inclination of the passing-beam or, when applicable, the vertical inclinations of all the different lighting units that provide or contribute to the cut-off(s) according to paragraph 6.22.6.1.2.1. above of the basic passing-beam, shall be verified for all loading conditions of the vehicle in accordance with the specifications in paragraphs 6.2.6.3.1. and 6.2.6.3.2. of this standard.

- 6.22.7. **Electrical connections**
- 6.22.7.1. Main-beam lighting (if provided by the AFS)
- 6.22.7.1.1. The lighting units for the main-beam may be activated either simultaneously or in pairs.
- For changing over from the dipped-beam to the main-beam at least one pair of lighting units for the main-beam shall be activated. For changing over from the main-beam to the dipped-beam all lighting units for the main-beam shall be de-activated simultaneously.
- 6.22.7.1.2. The main-beam may be designed to be adaptive, subject to the provisions in paragraph 6.22.9.3., the control signals being produced by a sensor system which is capable of detecting and reacting to each of the following inputs:
- (a) Ambient lighting conditions;
 - (b) The light emitted by the front lighting devices and front light-signalling devices of oncoming vehicles;
 - (c) The light emitted by the rear light-signaling of preceding vehicles
- Additional sensor functions to improve performance are allowed.
- For the purpose of this paragraph, "vehicles" means vehicles of categories L, M, N, O, T, as well as bicycles, such vehicles being equipped with retro-reflectors, with lighting and light-signaling devices, which are switched ON.
- 6.22.7.1.3. It shall always be possible to switch the main-beam headlamps, adaptive or non- adaptive, ON and OFF manually and to manually switch OFF the automatic control.
- Moreover, the switching OFF, of the main-beam headlamps and of their automatic control, shall be by means of a simple and immediate manual operation; the use of sub-menus is not allowed.
- 6.22.7.1.4. The dipped-beams may remain switched ON at the same time as the main beams.
- 6.22.7.1.5. Where four concealable lighting units are fitted their raised position must prevent the simultaneous operation of any additional headlamps fitted, if these are intended to provide light signals consisting of intermittent illumination at short intervals (see paragraph 5.12.) in day-light.
- 6.22.7.2. Passing-beam lighting:
- (a) The control for changing over to the dipped-beam shall switch off all main-beam headlamps or de-activate all AFS lighting units for the main-beam simultaneously;
 - (b) The dipped-beam may remain switched on at the same time as the main-beams;
 - (c) In the case of lighting units for the dipped-beam being equipped with gas discharge light sources, the gas-discharge light sources shall remain switched on during the main-beam operation.

- 6.22.7.3. Switching ON and OFF the passing-beam may be automatic, however subject to the requirements for "Electrical connection" in paragraph 5.12. of this standard.
- 6.22.7.4. Automatic operation of the AFS
- The changes within and between the provided classes and their modes of the AFS lighting functions as specified below, shall be performed automatically without causing discomfort, distraction or glare, neither for the driver nor for other road users.
- The following conditions apply for the activation of the classes and their modes of the passing-beam and, where applicable, of the main-beam and/or the adaptation of the main- beam.
- 6.22.7.4.1. The class C mode(s) of the passing-beam shall be activated if no mode of another passing-beam class is activated.
- 6.22.7.4.2. The class V mode(s) of the passing-beam shall not operate unless one or more of the following conditions is/are automatically detected (V-signal applies):
- (a) Roads in built-up areas and the vehicle's speed not exceeding 60 km/h;
 - (b) Roads equipped with a fixed road illumination, and the vehicle's speed not exceeding 60 km/h;
 - (c) A road surface luminance of 1 cd/m^2 and/or a horizontal road illumination of 10 lx being exceeded continuously;
 - (d) The vehicle's speed not exceeding 50 m/h.
- 6.22.7.4.3. The class E mode(s) of the passing-beam shall not operate unless the vehicle's speed exceeds 70 km/h and one or more of the following conditions is/are automatically detected.
- (a) The road characteristics correspond to motorway conditions and/or the vehicle's speed exceeds 110 km/h (E-signal applies);
 - (b) In case of a class E mode of the passing-beam which, according to the system's approval documents /communication sheet, complies with a 'data set' of Table 6 of Annex 3 of Standard No AIS-127
- Data set E1: the vehicle's speed exceeds 100 km/h
(E1-signal applies); Data set E2: the vehicle's speed exceeds 90 km/h (E2-signal applies); Data set E3: the vehicle's speed exceeds 80 km/h (E3-signal applies).
- 6.22.7.4.4. The class W-mode(s) of the passing-beam shall not operate unless the front fog lamps, if any, are switched OFF and one or more of the following conditions is/are automatically detected (W-signal applies):
- (a) The wetness of the road has been detected automatically;
 - (b) The windshield wiper is switched ON and its continuous or automatically controlled operation has occurred for a period of at least two minutes.

- 6.22.7.4.5. A mode of a class C, V, E, or W passing-beam shall not be modified to become a bending mode of said class (T-signal applies in combination with the signal of said passing-beam class according to paragraphs 6.22.7.4.1. through 6.22.7.4.4. above) unless at least one of the following characteristics (or equivalent indications) are evaluated:
- (a) The angle of lock of the steering;
 - (b) The trajectory of the centre of gravity of the vehicle. In addition, the following provisions apply:
 - (i) A horizontal movement of the asymmetric cut-off side-wards from the longitudinal axis of the vehicle, if any, is allowed only when the vehicle is in forward motion and shall be such that the longitudinal vertical plane through the kink of the elbow of the cut-off does not intersect the line of the trajectory of the centre of gravity of the vehicle at distances from the front of the vehicle which are larger than 100 times the mounting height of the respective lighting unit;
 - (ii) One or more lighting units may be additionally energized only when the horizontal radius of curvature of the trajectory of the centre of gravity of the vehicle is 500 m or less.
- 6.22.7.5. It shall always be possible for the driver to set the AFS to the neutral state and to return it to its automatic operation.
- 6.22.8. **Tell-tale:**
- 6.22.8.1. The provisions of paragraphs 6.1.8. (for the main-beam headlamp) and 6.2.8. (for the dipped-beam headlamp) of this standard apply to the respective parts of an AFS.
- 6.22.8.2. A visual failure tell-tale for AFS is mandatory. It shall be non-flashing. It shall be activated whenever a failure is detected with respect to the AFS control signals or when a failure signal is received in accordance with paragraph 5.9. of standard No. AIS-127. It shall remain activated while the failure is present. It may be cancelled temporarily, but shall be repeated whenever the device which starts and stops the engine is switched on and off.
- 6.22.8.3. If the main-beam is adaptive, a visual tell-tale shall be provided to indicate to the driver that the adaptation of the main beam is activated. This information shall remain displayed as long as the adaptation is activated.
- 6.22.8.4. A tell-tale to indicate that the driver has set the system into a state according to paragraph 5.8. of Standard No. AIS-127 is optional.

6.22.9. Other requirements

6.22.9.1. An AFS shall be permitted only in conjunction with the installation of headlamp cleaning device(s) according to AIS-083 for at least those lighting units, to standard No. AIS-127, if the total objective luminous flux of the light sources of these units exceeds 2,000 lm per side, and which contribute to the class C (basic) passing-beam.

6.22.9.2. Verification of compliance with AFS automatic operating requirements

6.22.9.2.1. The applicant shall demonstrate with a concise description or other means acceptable to the test agency responsible for type approval:

(a) The correspondence of the AFS control signals

i) To the description required in paragraph 3.2.6. of this standard; and

ii) To the respective AFS control signals specified in the AFS type approval documents; and

(b) Compliance with the automatic operating requirements according to paragraphs 6.22.7.4.1. through 6.22.7.4.5. above.

6.22.9.2.2. To verify, whether, according to the paragraph 6.22.7.4., the AFS automatic operation of the passing-beam functions does not cause any discomfort, the technical service shall perform a test drive which comprises any situation relevant to the system control on the basis of the applicants description; it shall be notified whether all modes are activated, performing and de-activated according to the applicant's description; obvious malfunctioning, if any, shall be contested (e.g. excessive angular movement or flicker).

6.22.9.2.3. The overall performance of the automatic control shall be demonstrated by the applicant by documentation or by other means accepted by test agency responsible for type approval. Furthermore, the manufacturer shall provide a documentation package which gives access to the design of "the safety concept" of the system. This "safety concept" is a description of the measures designed into the system, for example within the electronic units, so as to address system integrity and thereby ensure safe operation even in the event of mechanical or electrical failure which could cause any discomfort, distraction or glare, either to the driver or to oncoming and preceding vehicles. This description shall also give a simple explanation of all the control functions of the "system" and the methods employed to achieve the objectives, including a statement of the mechanism(s) by which control is exercised.

A list of all input and sensed variables shall be provided and the working range of these shall be defined. The possibility of a fall-back to the basic passing-beam (class C) function shall be a part of the safety concept.

The functions of the system and the safety concept, as laid down by the manufacturer, shall be explained. The documentation shall be brief, yet provide evidence that the design and development has had the benefit of expertise from all the system fields which are involved.

For periodic technical inspections, the documentation shall describe how the current operational status of the "system" can be checked.

For Type Approval purposes this documentation shall be taken as the basic reference for the verification process.

6.22.9.2.4. To verify, that the adaptation of the main-beam does not cause any discomfort, distraction or glare, neither to the driver nor to oncoming and preceding vehicles, the technical service shall perform a test drive according to paragraph 2 in Annex G. This shall include any situation relevant to the system control on the basis of the applicant's description. The performance of the adaptation of the main-beam shall be documented and checked against the applicant's description. Any obvious malfunctioning shall be contested (e.g. excessive angular movement or flicker).

6.22.9.3. Adaptation of the main-beam

6.22.9.3.1. The sensor system used to control the adaptation of the main-beam, as described in paragraph 6.22.7.1.2., shall comply with the following requirements:

6.22.9.3.1.1. The boundaries of the minimum fields in which the sensor is able to detect light emitted or retro-reflected from other vehicles as defined in paragraph 6.22.7.1.2. are given by the angles indicated in paragraph 6.1.9.3.1.1. to this standard.

6.22.9.3.1.2. The sensor system sensitivity shall comply with the requirements in Paragraph 6.1.9.3.1.2. to this standard.

6.22.9.3.1.3. The adaptive main-beam shall be switched off when the illuminance produced by ambient lighting conditions exceeds 7,000 lx.

Compliance with this requirement shall be demonstrated by the applicant, using simulation or other means of verification accepted by the authority responsible for type approval. If necessary the illuminance shall be measured on a horizontal surface, with a cosine corrected sensor on the same height as the mounting position of the sensor on the vehicle. This may be demonstrated by the manufacturer by sufficient documentation or by other means accepted by the test agency responsible for type approval.

6.22.9.4. The aggregate maximum intensity of the lighting units that can be energized simultaneously to provide the main-beam lighting or its modes, if any, shall not exceed 430,000 cd, which corresponds to a reference value of 100.

This maximum intensity shall be obtained by adding together the individual reference marks indicated on the several installation units that are simultaneously used to provide the main-beam.

- 6.22.9.5. The means according to the provisions of paragraph 5.8. of Standard AIS 127-2016, which allow the vehicle to be used temporarily in a territory with the opposite direction of driving than that for which approval is sought, shall be explained in detail in the owner's manual.
- 6.23. **Emergency stop signal**
- 6.23.1. **Presence**
Optional.
The emergency stop signal shall be given by the simultaneous operation of all the stop or direction-indicator lamps fitted as described in paragraph 6.23.7.
- 6.23.2. **Number**
As specified in paragraph 6.5.2. or 6.7.2.
- 6.23.3. **Arrangement**
As specified in paragraph 6.5.3. or 6.7.3.
- 6.23.4. **Position**
As specified in paragraph 6.5.4. or 6.7.4.
- 6.23.5. **Geometric visibility**
As specified in paragraph 6.5.5. or 6.7.5.
- 6.23.6. **Orientation**
As specified in paragraph 6.5.6. or 6.7.6.
- 6.23.7. **Electrical connections**
- 6.23.7.1. All the lamps of the emergency stop signal shall flash in phase at a frequency of 4.0 ± 1.0 Hz.
- 6.23.7.1.1. However, if any of the lamps of the emergency stop signal to the rear of the vehicle use filament light sources the frequency shall be $4.0 +0.0/-1.0$ Hz.
- 6.23.7.2. The emergency stop signal shall operate independently of other lamps.
- 6.23.7.3. The emergency stop signal shall be activated and deactivated automatically.
- 6.23.7.3.1. The emergency stop signal shall be activated only when the vehicle speed is above 50 km/h and the braking system is providing the emergency braking logic signal defined in standard IS 11852-2013 & IS 15986
- 6.23.7.3.2. The emergency stop signal shall be automatically deactivated if the emergency braking logic signal as defined in standard IS 11852 & IS 15986 is no longer provided or if the hazard warning signal is activated.
- 6.23.8. **Tell-tale**
Optional.

6.23.9. **Other requirements**

6.23.9.1. Except as provided in paragraph 6.23.9.2. below, if a motor vehicle is equipped to tow a trailer, the control of the emergency stop signal on the motor vehicle shall also be capable of operating the emergency stop signal on the trailer.

When the motor vehicle is electrically connected to a trailer, the operating frequency of the emergency stop signal for the combination shall be limited to the frequency specified in paragraph 6.23.7.1.1. However, if the motor vehicle can detect that filament light sources are not being used on the trailer for the emergency stop signal, the frequency may be that specified in paragraph 6.23.7.1.

6.23.9.2. If a motor vehicle is equipped to tow a trailer fitted with a service braking system of either continuous or semi-continuous type, as defined in standard IS 11852, it shall be ensured that a constant power supply is provided via the electrical connector for the stop lamps to such trailers while the service brake is applied.

The emergency stop signal on any such trailer may operate independently of the towing vehicle and is not required to operate either at the same frequency as, or in phase with that on the towing vehicle.

6.24. **Exterior courtesy lamp**

6.24.1. **Presence**

Optional on motor vehicles.

6.24.2. **Number**

No special requirements.

6.24.3. **Arrangement**

No special requirement.

6.24.4. **Position**

No special requirement.

6.24.5. **Geometric visibility**

No special requirement.

6.24.6. **Orientation**

No special requirement.

6.24.7. **Electrical connections**

No special requirement.

6.24.8. **Tell-tale**

No special requirement.

6.24.9. **Other requirements**

The exterior courtesy lamp shall not be activated unless the vehicle is stationary and one or more of the following conditions is satisfied:

- (a) The engine is stopped; or

- (b) A driver or passenger door is opened; or
- (c) A load compartment door is opened.

The provisions of paragraph 5.10. shall be met in all fixed positions of use.

6.25. **Rear-end collision alert signal**

6.25.1. **Presence**

Optional.

The rear-end collision alert signal shall be given by the simultaneous operation of all the direction indicator lamps fitted as described in paragraph 6.25.7.

6.25.2. **Number**

As specified in paragraph 6.5.2.

6.25.3. **Arrangement**

As specified in paragraph 6.5.3.

6.25.4. **Position**

As specified in paragraph 6.5.4.

6.25.5. **Geometric visibility**

As specified in paragraph 6.5.5.

6.25.6. **Orientation**

As specified in paragraph 6.5.6.

6.25.7. **Electrical connections.**

Compliance with these requirements shall be demonstrated by the applicant, by simulation or other means of verification accepted by the test agency responsible for type approval.

6.25.7.1. All the lamps of the rear-end collision alert signal shall flash in phase at a frequency of 4.0 +/- 1.0 Hz

6.25.7.1.1. However, if any of the lamps of the rear end collision alert signal to the rear of the vehicle use filament light sources the frequency shall be 4.0 +0.0/-1.0 Hz.

6.25.7.2. The rear-end collision alert signal shall operate independently of Other lamps.

6.25.7.3. The rear-end collision alert signal shall be activated and deactivated automatically.

6.25.7.4. The rear-end collision alert signal shall not be activated if the direction indicator lamps, the hazard warning signal or the emergency stop signal is activated.

6.25.7.5. The rear-end collision alert signal may only be activated under the following conditions:

Vr	activation
$V_r > 30 \text{ km/h}$	$TTC \leq 1.4$
$V_r \leq 30 \text{ km/h}$	$TTC \leq 1.4 / 30 \times V_r$

"Vr (Relative Speed)": means the difference in speed between a vehicle with rear-end collision alert signal and a following vehicle in the same lane.

"TTC (Time to collision)": means the estimated time for a vehicle with rear-end collision alert signal and a following vehicle to collide assuming the relative speed at the time of estimation remains constant.

- 6.25.7.6. The activation period of the rear-end collision alert signal shall be not more than 3 seconds.
- 6.25.8. **Tell-tale**
Optional.
- 6.26. **Manoeuvring lamp**
- 6.26.1. **Presence**
Optional on motor vehicles.
- 6.26.2. **Number**
One or two (one per side).
- 6.26.3. **Arrangement**
No special requirement, however the requirements of paragraph 6.26.9. apply.
- 6.26.4. **Position**
No special requirement.
- 6.26.5. **Geometric Visibility**
No special requirement.
- 6.26.6. **Orientation**
Downwards, however the requirements of paragraph 6.26.9. apply.
- 6.26.7. **Electrical Connections**
Manoeuvring lamps shall be so connected that they cannot be activated unless the main- beam headlamps or the dipped-beam headlamps are switched ON at the same time.
The maneuvering lamp(s) shall be activated automatically for slow manoeuvres up to 10 km/h provided that one of the following conditions is fulfilled:
- Prior to the vehicle being set in motion for the first time after each manual activation of the propulsion system; or
 - Reverse gear is engaged; or
 - A camera based system which assists parking manoeuvres is activated.

The manoeuvring lamps shall be automatically switched off if the forward speed of the vehicle exceeds 10 km/h and they shall remain switched off until the conditions for activation are met again.

6.26.8. **Tell-tale**

No special requirement.

6.26.9. **Other requirements**

6.26.9.1. The test agency responsible for type- approval, perform a visual test to verify that there is no direct visibility of the apparent surface of these lamps, if viewed by an observer moving on the boundary of a zone on a transverse plane 10 m from the front of the vehicle, a transverse plane 10 m from the rear of the vehicle, and two longitudinal planes 10 m from each side of the vehicle; these four planes to extend from 1 m to 3 m above and parallel to the ground as shown in Annex I.

6.26.9.2. At the request of the applicant and with the consent of the test agency the requirement of 6.26.9.1 may be verified by a drawing or simulation or deemed be satisfied if the installation conditions comply with paragraph 6.2.3 of Standard.

7.0 TECHNICAL SPECIFICATIONS TO BE SUBMITTED

7.1 The specifications to be submitted by the manufacturer at the time of applying for the type approval of the vehicle to this standard shall contain at least the information listed in the following paragraphs of AIS-007 (Rev.5).

A1, A1.1, A1.2, A1.3, A1.4, A1.5, A1.6, A1.7. A3, A3.1, A3.2.1 A6, A6.1, A6.1.1, A6.1.2, A6.1.3, A6.2 A10, A10.1, A10.2, A10.3 A7, A7.2.1, A7.2.2, A7.2.3, A7.3, A7.3.1, A7.3.2, A7.4, A7.4.1, A7.4.2 B10, B10.1, B10.5. E2, E2.1, E2.2, E2.3 E3, E3.1, E3.2, E3.3 E4, E4.1, E4.2, E4.3 E5, E5.1, E5.2, E5.3 E6, E6.1, E6.1.1, E6.1.2, E6.1.3, E6.2, E6.2.1, E6.2.3 E7, E7.1, E7.2, E7.3 E8, E8.1, E8.2, E8.3 E9, E9.1, E9.1.1, E9.1.2, E9.1.3, E9.2, E9.2.1, E9.2.2, E9.2.3, E9.3, E9.3.1, E9.3.2, E9.3.3, E9.3.4. E10, E10.1, E10.1.1, E10.1.2, E10.1.3, E10.2, E10.2.1, E10.2.3, E10.3, E10.3.1, E10.3.2, E10.3.3 E11, E11.1, E11.1.1, E11.1.2, E11.1.3, E11.1.4, E11.2, E11.2.1, E11.2.3, E11.2.4, E11.3, E11.3.1, E11.3.2, E11.3.3, E11.3.4. E12, E12.1, E12.2, E12.3.

7.2 In addition, the maximum intensity of main-beam head lamp (cd) and a diagram of the vehicle indicating the location of all lighting and light signalling devices and following dimensions (in mm) shall be submitted.

7.2.1 **Along the Width of the Vehicle** (applicable only in case there are more than one lamp for same function).

7.2.1.1 Horizontal distance between the inner edges of apparent surfaces in the direction of reference axes or illuminating surfaces, as applicable.

7.2.1.2 Distance between outermost edges of the apparent surfaces in the direction of reference axes or illuminating surfaces, as applicable from the extreme outer edge of the vehicle.

- 7.2.1.3 Distance between the nearest points of apparent surfaces in the direction of reference axes of the front direction indicator and the dipped-beam headlamps and category of the front direction indicator 1 or 1a or 1b. and that of rear direction indicator 2a or 2b.
- 7.2.1 **Along Length of the Vehicle Where Applicable:**
- 7.2.2 The distance between the edges of the apparent surfaces in the direction of reference axis or illuminating surfaces or light emitting surfaces, as applicable and the transverse plane which marks the forward boundary of the vehicle's overall length.
- 7.2.3 **Height:** Heights of highest and lowest points of apparent surfaces in the direction of reference axes or illuminating surfaces or light-emitting surfaces, as applicable from ground.
- 7.2.4 Contour of the vehicle parts limiting the geometric visibility of the lamps (where applicable).
- 7.2.5 Reference axis of the device.
- 7.2.6 Location of the extreme outer edge of the vehicle.
- 7.2.7 Mark of the illuminating surface, light-emitting surface or apparent surface in the direction of reference axis, as applicable, of the device as declared by the manufacturer.
- 7.2.8 Mark of the median longitudinal plane of the vehicle.
- 7.3 If the above information is submitted in a consolidated form of AIS-007 (Rev. 5), for the type approval of the whole vehicle, it is not necessary to submit this information again.
- 7.4 **Changes in the technical specifications already type approved:**
- 7.4.1 Every modification pertaining to the information declared in accordance with paragraph 7.1, 7.2 shall be intimated by the manufacturer to the certifying agency.
- 7.4.2 If the changes in parameters are not related to the provisions, no further action needs to be taken. If the changes in parameters are related to the provisions, the Testing Agency may then consider whether,
- a) the model with the changed specifications still complies with provision;
 - or
 - b) any further verification is required to establish compliance. For considering whether any further verification is required or not, guidelines given in paragraph 8 (Criteria for Extension of Approval) may be used.
- 7.4.3 In case of 7.4.2(b), verification for only those parameters which are affected by the modifications need to be carried out.
- 7.4.4 In case of fulfilment of criteria of paragraph 7.4.2 a), or after results of further verification as per paragraph 7.4.2 b) are successful, the approval of compliance shall be extended for the changes carried out.

8.0 CRITERIA FOR EXTENSION OF APPROVAL

- 8.1 In case of following changes, the verification shall be carried out for establishing compliance of the changed parameters to the requirements specified in this standard.
- 8.2 Number of any of the mandatory lighting and light signalling devices and any addition to fitment of optional lamps.
- 8.3 In case any increase in the dimensions for which a minimum value is specified or any decrease in the dimensions for which a maximum value is specified in this standard, verification on the prototype is not required if the difference between the modified dimension declared by the manufacturer and the requirement specified in this standard is more than 25 mm.
- 8.4 If there are changes in the contour of the vehicle, which increase the geometric visibility, verification on the prototype is not required.
- 8.5 While approving fitment of different makes of lighting devices or light-signalling devices, if any of the parameters specified above are affected, verification of compliance to such parameters shall be carried out.
- 8.6 In case of following changes, the compliance to the paragraph.6.2.6.1.2 of the standard, verification by way of actual testing or by calculations, is required,
 - 8.6.1 Decrease in the wheel base by more than 10 percent
 - 8.6.2 Decrease in the height of head lamp in unladen condition.
 - 8.6.3 Increase in GVW by more than 10 percent
 - 8.6.4 Increase in the ratio of FAW (Front Axle Weight) to RAW (Rear Axle Weight) in unladen condition.
- 8.7 For changes other than the above, the provisions given in the Preamble of Annex C of AIS-017 (Procedure for Type Approval and Certification of Vehicles for Compliance to Central Motor Vehicles Rules) may be followed.

9.0 CONFORMITY OF PRODUCTION REQUIREMENTS

Whole vehicle COP procedure laid down by the Ministry of Road Transport & Highways shall be applicable. For the purpose of COP, verification of parameters decided in COP standard shall be carried out.

10.0 TRANSITIONAL PROVISIONS

At the request of the applicant, type approvals for compliance to AIS-008 (Rev.2):2018, shall be granted by test agencies from XX/YY/ Such type approvals shall be deemed to be compliance to AIS-008 (Rev.1): 2010

11.0 AMENDMENTS TO UN REGULATIONS AFTER THE LEVEL DESCRIBED IN PARA. 4 OF INTRODUCTION

11.1 Supplements

In case of changes in UN regulation, which are issued as supplements (Supplements do not affect the earlier type approvals) at the request of applicant, approval of compliance to this standard shall be issued taking into account the changes arising out of such supplement(s) to UN regulation with approval from Chairman AISC.

This shall be incorporated in the test report.

Note: Such changes will be considered for inclusion in this standard at the time of its next amendment /revision.

11.2 Series of amendments

Changes in UN regulation, which are issued as series of amendments (series of amendments may affect the earlier type approvals) will not be considered for issuing approval to this standard.

However, Chairman, AISC may, on a case to case basis, permit to accept latest series of amendments.

This shall be incorporated in the test report.

Note: Such changes will be considered for inclusion in this standard at the time of its next revision.

11.3 Examples of lamp surfaces, axes, centers of reference, and angles of geometric visibility

These examples show some arrangements to aid the understanding of the provisions and are not intended to be design restrictive.

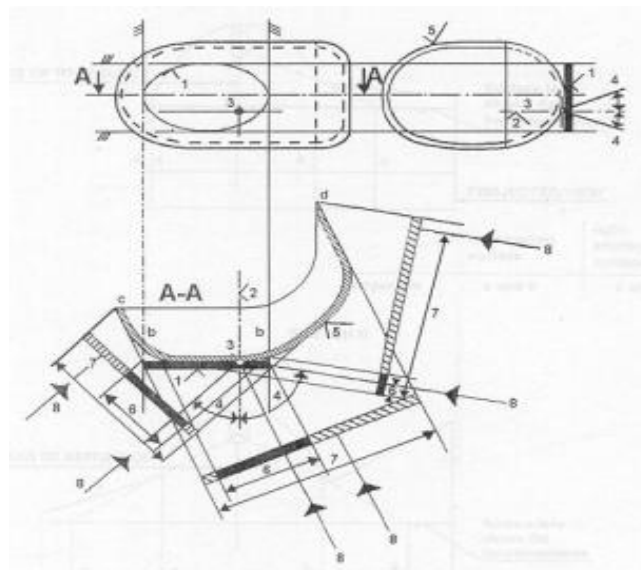
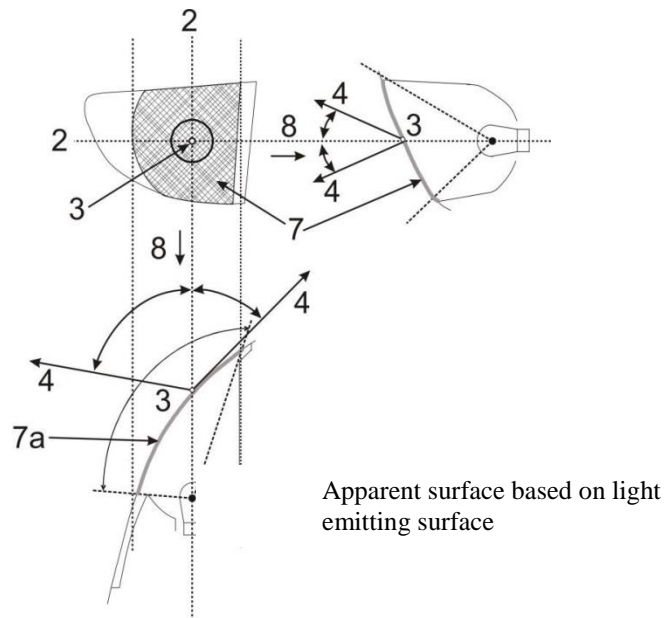

Figure
Lamp Surfaces, Axis and Center of Reference and
Angles of Geometric Visibility (Ref. paragraphs 2.8, 2.9 and 2.10)

KEY for all examples in this Annex:			
1.	Illuminating surface	IO	Inner optical part
2.	Axis of reference	LG	Light guide
3.	Centre of reference	L	Outer lens
4.	Angle of geometric visibility	R	Reflector
5.	Light-emitting surface	S	Light source
6.	Apparent surface based on the illuminating surface	X	Not part of this function
7a	Apparent surface based on the light-emitting surface according to paragraph 2.8. a) (With outer lens)	F1	Function one
7b	Apparent surface based on the light-emitting surface according to paragraph 2.8. b) (Without outer lens)	F2	Function two
8	Direction of visibility		

Part 1 – Light emitting surface of a light-signalling device other than a retro- reflector



Part 2 – Illuminating surface of a light-signalling device other than a retro-reflector

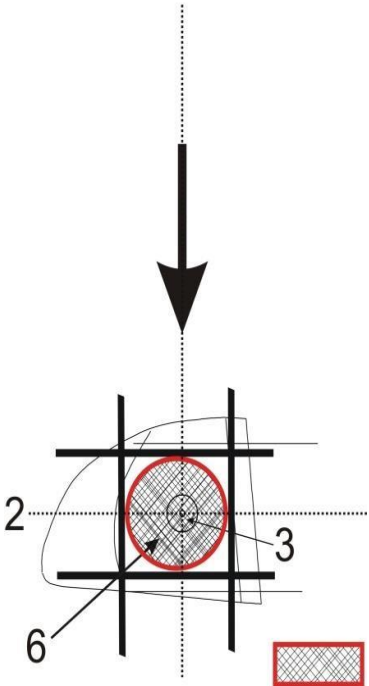
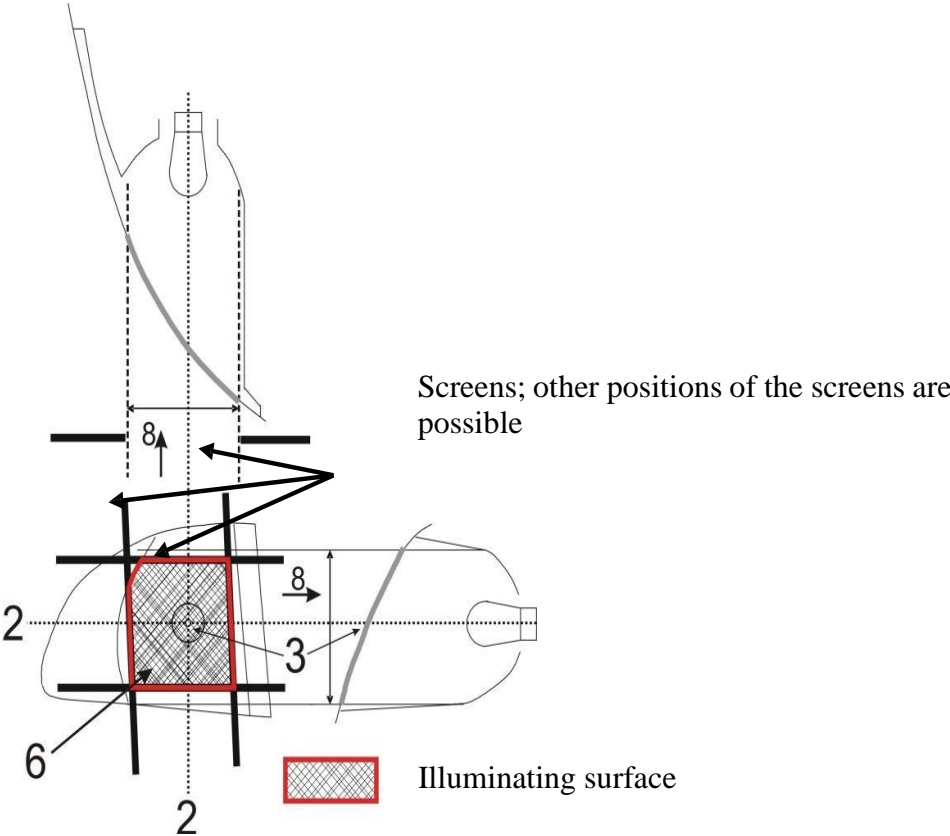

Part 3 – Examples of apparent surface based on illuminating surface in different directions of geometric visibility

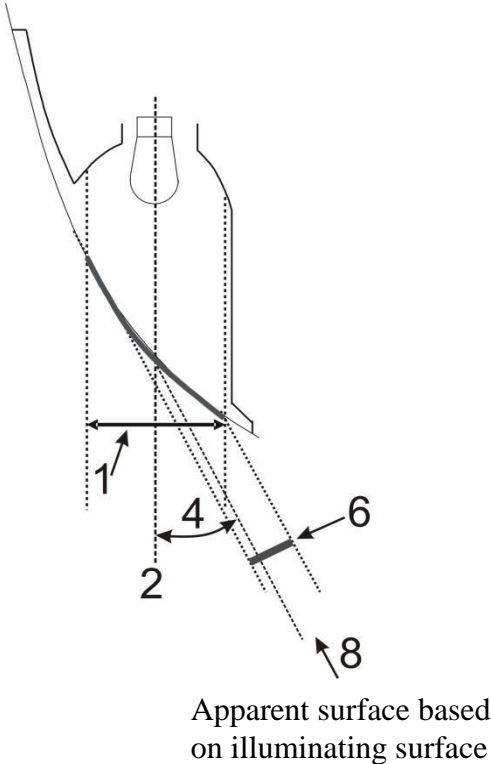
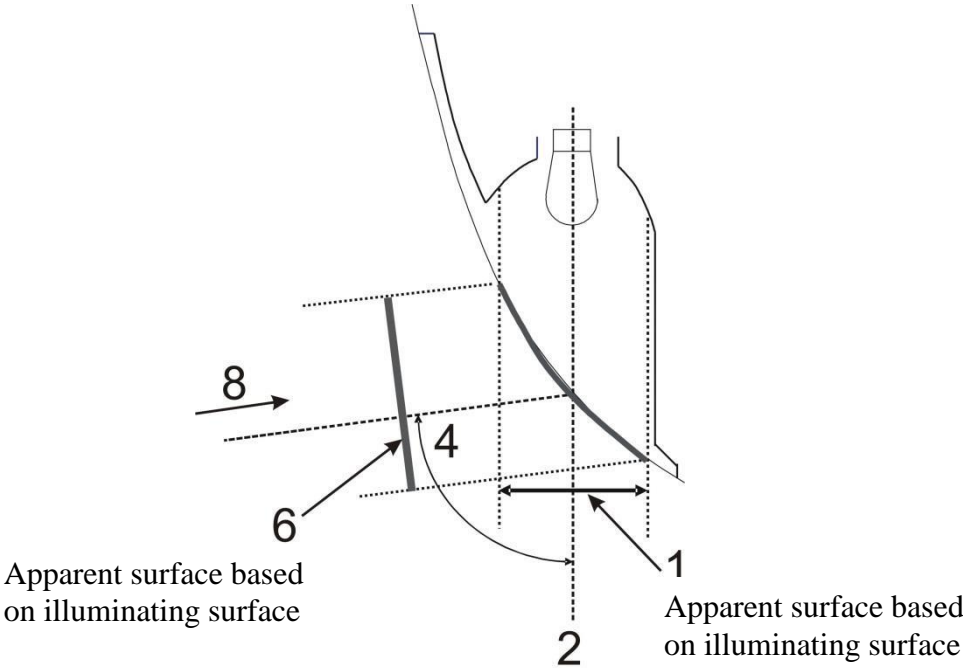

Part 4 - Examples of apparent surface based on light emitting surface in different directions of geometric visibility

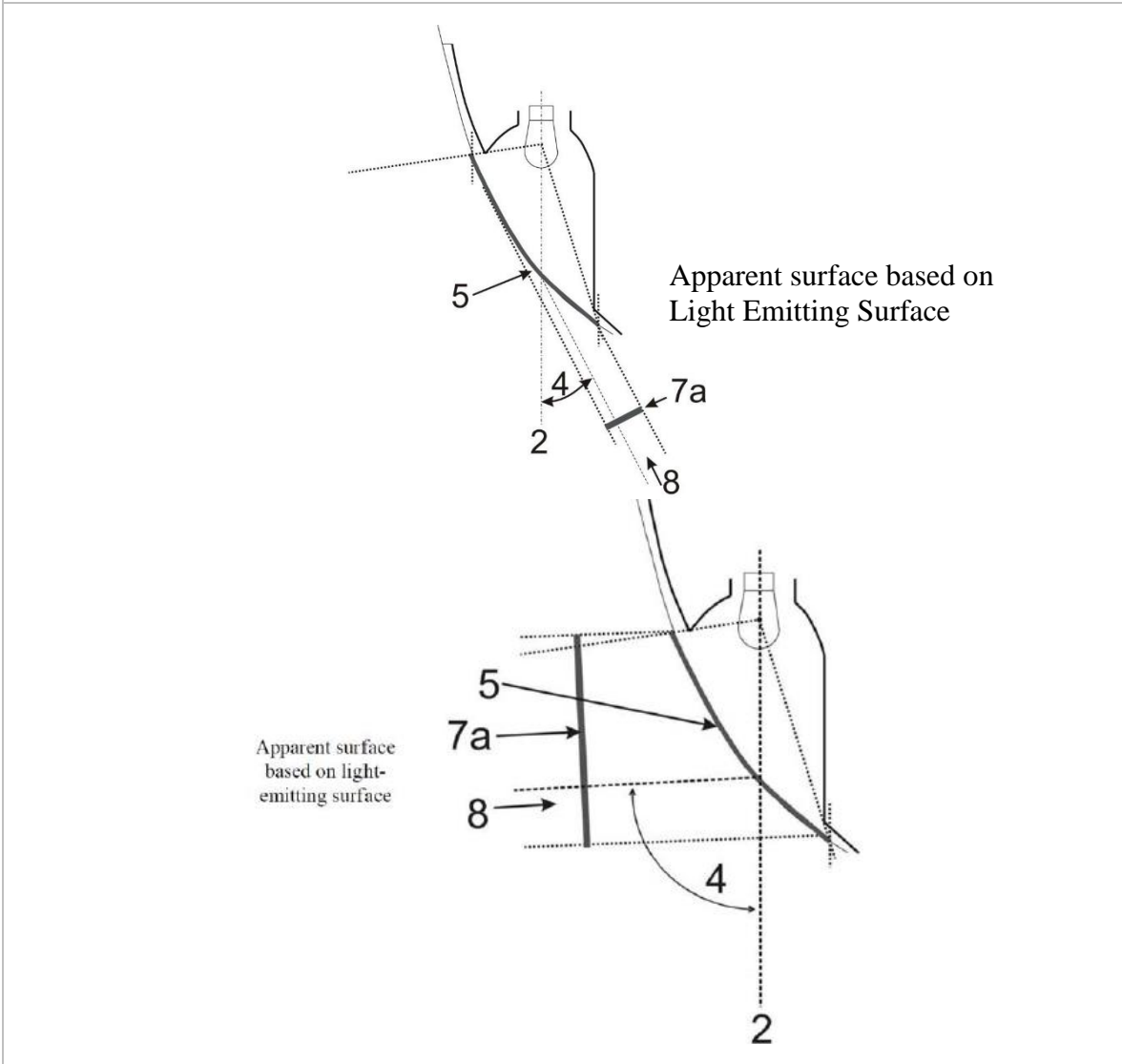

Part 5 – Example of illuminating surface in comparison with light-emitting surface in the case of a "single function lamp"

(see paragraphs 2.8. to 2.9. of this Standard)

Examples of a light source with a reflector optic behind an outer lens:

Example 1	Example 2
<p>Diagram of Example 1: A light source (5) is positioned behind a reflector (R) and an outer lens (L). A dashed line (2) represents the light-emitting surface. A vertical dimension line (6) and a horizontal dimension line (7a) are shown. A label 'S' is also present.</p>	<p>Diagram of Example 2: A light source (5) is positioned behind a reflector (R) and an outer lens (L). A dashed line (2) represents the light-emitting surface. A vertical dimension line (6) and a horizontal dimension line (7b) are shown. A label 'S' is also present.</p>
(Including the outer lens)	(Excluding the non-textured outer lens)

Examples of a light source with a reflector optic with a inner lens behind an outer lens:

Example 3	Example 4
(Including the outer lens)	(Excluding the non-outer lens)

Examples of a light source with a reflector optic with a partial inner lens behind an outer lens

Example 5	Example 6
(Including the outer lens)	(Excluding the non-textured outer lens)

Example of a light guide optic behind an outer lens:

Example 7
<p>Example 7</p> <p style="text-align: center;">Section AA</p> <div style="display: flex; align-items: center; margin-top: 10px;"> <div style="width: 20px; height: 15px; background-color: red; margin-right: 5px;"></div> <p>In the case where the non-textured outer lens is excluded, "7b" is the apparent surface according to paragraph 2.8. b).</p> </div>

Example of a light guide optic or a reflector optic behind an outer lens:

Example 8

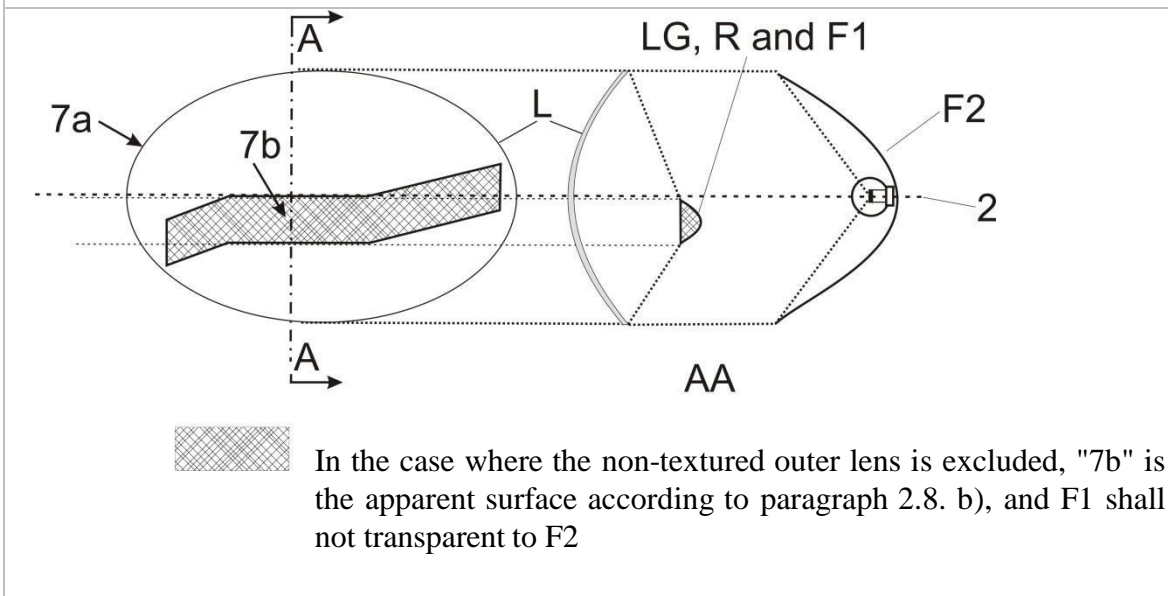

Example of a light source with a reflector optic in combination with an area which is not part of this function, behind an outer lens:

Example 9

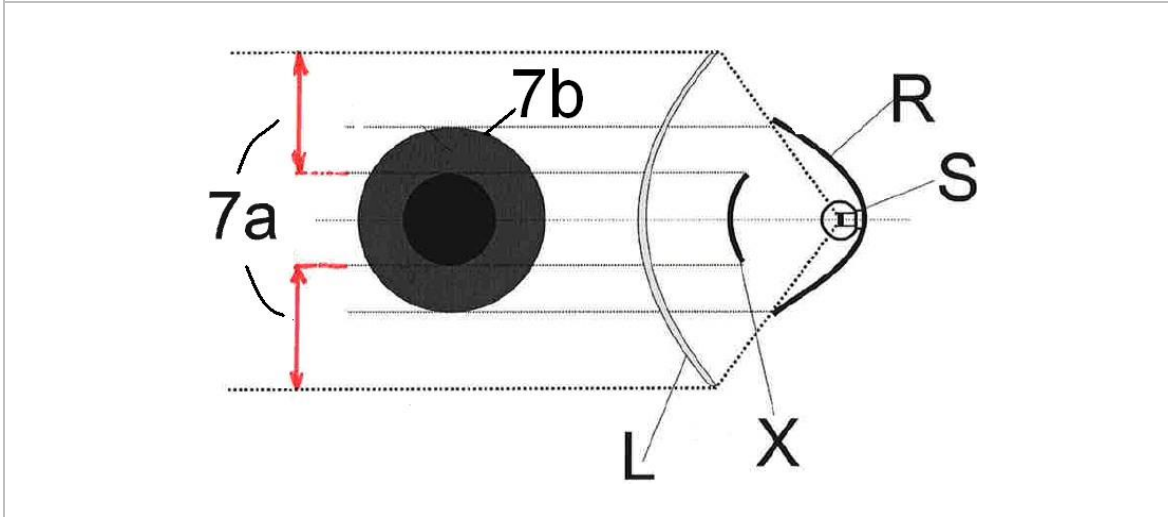

In the case where the non-textured outer lens is excluded, "7b" is the apparent surface according to paragraph 2.8. b)

Part 6 – Examples showing the determination of the light emitting surface in comparison with illuminating surface (See paragraphs 2.8. and 2.9. of this standard)

Note: Reflected light could / may contribute to the determination of the light emitting surface

Example A

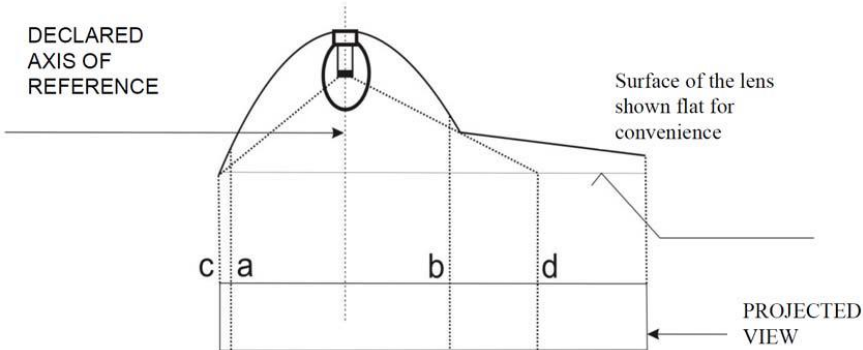

	Illuminating surface	Declared light-emitting surface according to 2.8. a)
Edges are	a and b	c and d

Example B

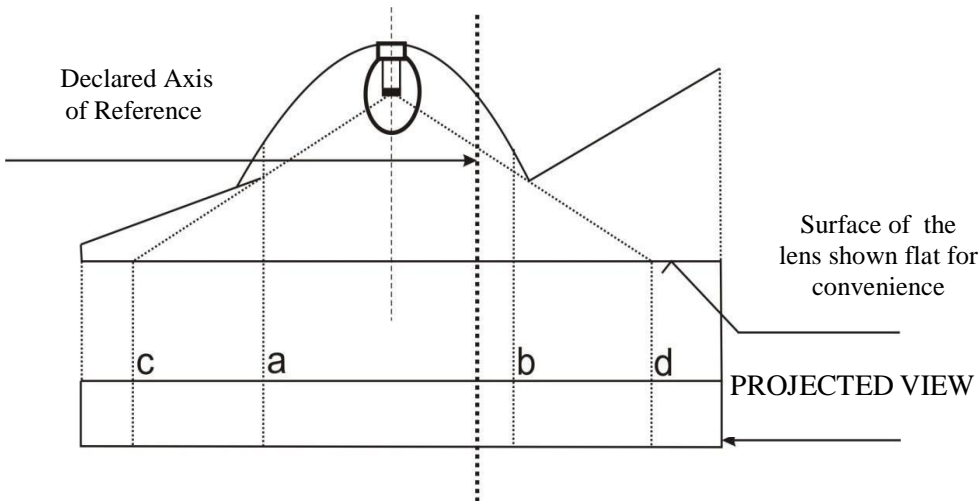

	Illuminating surface	Declared Light-emitting surface according to 2.8. a)
Edges are	a and b	c and d

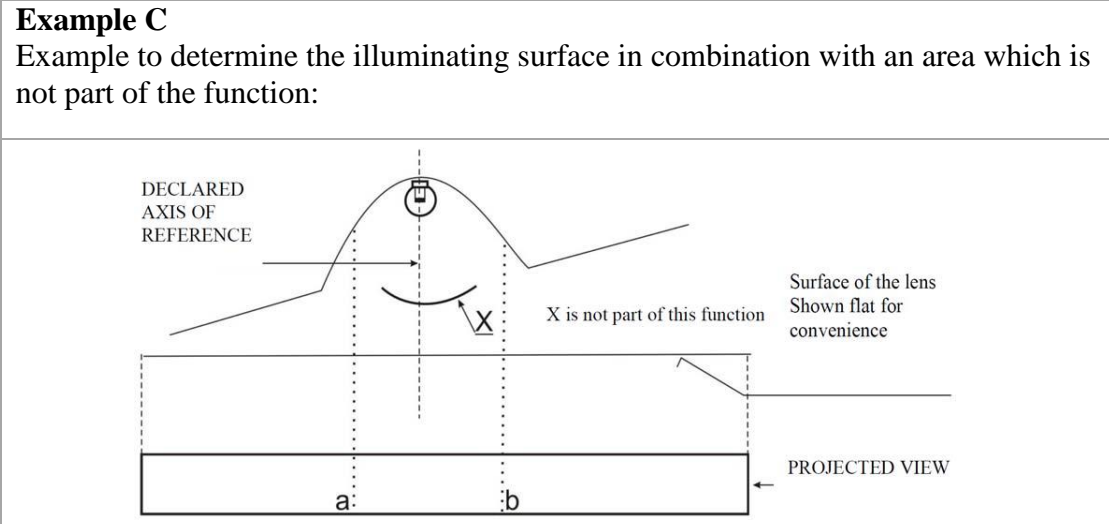

	Illuminating surface
Edges are	a and b

Example D
 Example to determine a light emitting surface according to 2.8. a) in combination with an area which is not part of the function:

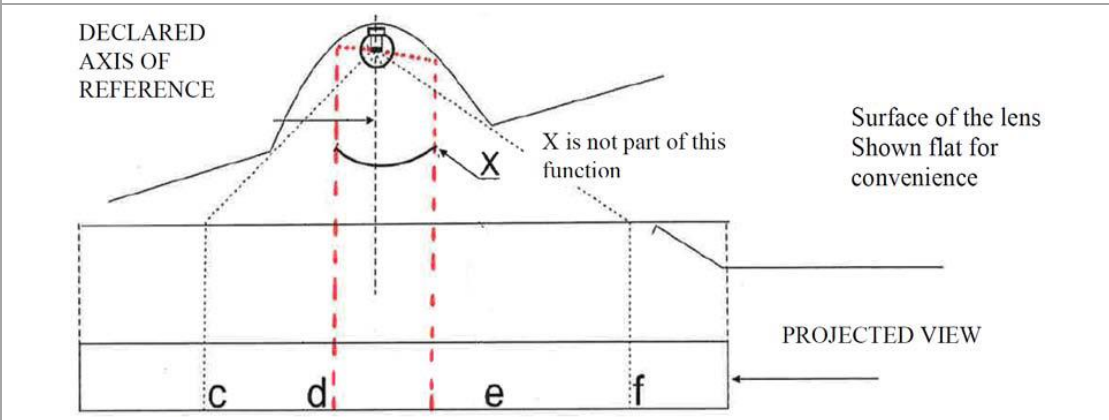

	Declared Light-emitting surface according to 2.8. a)
Edges are	c-d and e-f

Example E
 Example to determine the apparent surface in combination with an area which is not part of the function and a non-textured outer lens (according to 2.8. b)):

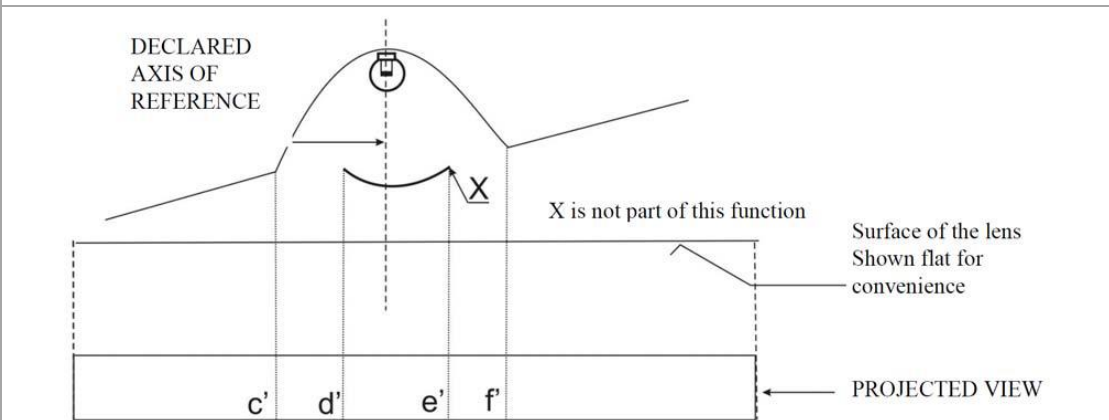

	Declared Light emitting surface according to 2.8 b) for example
Edges are	c'-d' and e'-f'

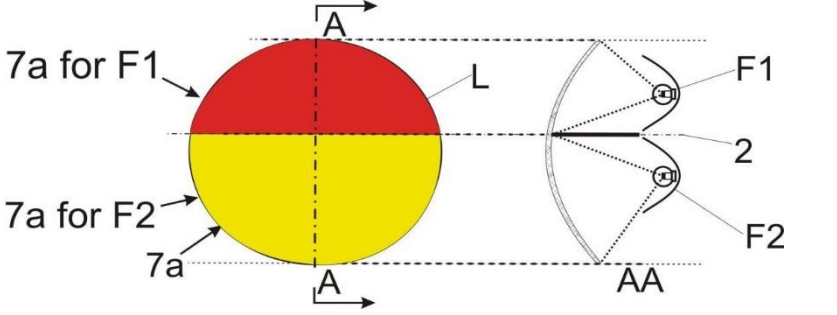
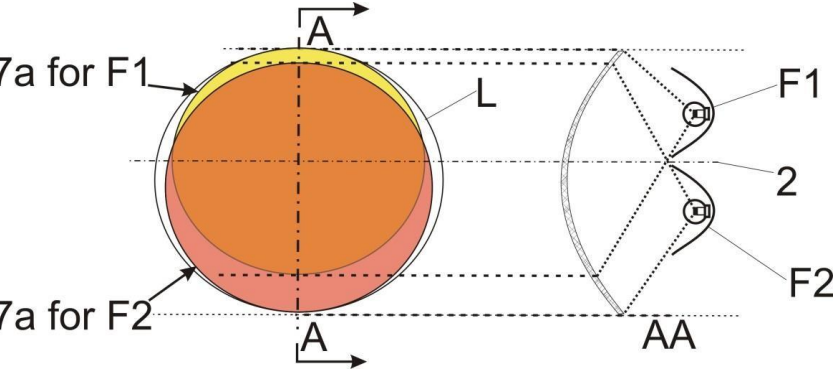
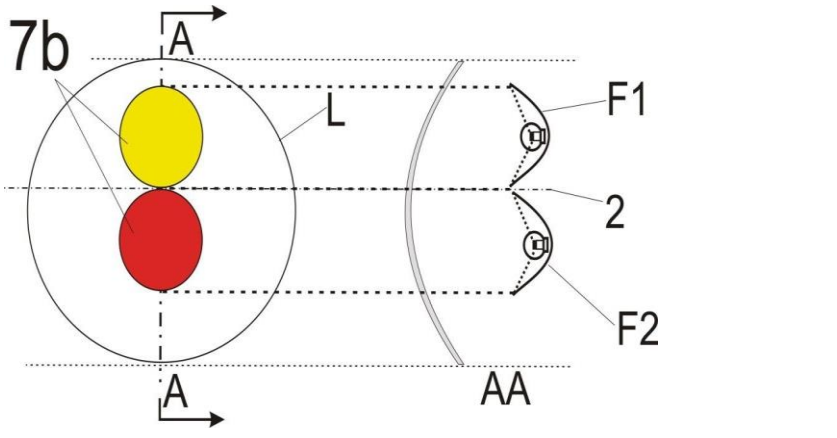
Part 7 - Examples to enable a decision regarding the reciprocal incorporation of two functions	
In the case with a textured outer lens and a wall in between:	
 <p>Diagram 7a shows a circular lens with a red upper half and a yellow lower half. A dashed vertical line 'A' with arrows at both ends passes through the center. A horizontal dashed line '2' is drawn across the lens. To the right, a cross-section of a lens with two focal points 'F1' and 'F2' is shown. A curved line 'L' represents the lens surface, and a dashed line 'AA' is at the bottom. A small circle '2' is located between the two focal points.</p>	Not Reciprocally incorporated
In the case with a textured outer lens:	
 <p>Diagram 7a shows a circular lens with a textured outer layer. The inner part is orange, and the outer part is yellow. A dashed vertical line 'A' with arrows at both ends passes through the center. A horizontal dashed line '2' is drawn across the lens. To the right, a cross-section of a lens with two focal points 'F1' and 'F2' is shown. A curved line 'L' represents the lens surface, and a dashed line 'AA' is at the bottom. A small circle '2' is located between the two focal points.</p>	Reciprocally incorporated
In the case where the non-textured outer lens is excluded:	
 <p>Diagram 7b shows a circular lens 'L' containing two smaller, vertically stacked lenses: a yellow one on top and a red one on the bottom. A dashed vertical line 'A' with arrows at both ends passes through the center of both lenses. A horizontal dashed line '2' is drawn across the lens. To the right, a cross-section of a lens with two focal points 'F1' and 'F2' is shown. A curved line 'L' represents the lens surface, and a dashed line 'AA' is at the bottom. A small circle '2' is located between the two focal points.</p>	Not Reciprocally incorporated

<p>In the case where the non-textured outer lens is excluded</p>	
<p>Diagram 7b: A lens L (circle) contains a red triangular lenslet with a yellow dot at its center. A vertical dashed line with arrows at both ends is labeled 'A'. To the right, a curved lens with a red rectangular lenslet is shown. Labels include 'LG and F1' pointing to the lenslet, 'F2' pointing to the focal point, '2' pointing to the lens surface, and 'AA' at the bottom.</p>	<p>Not Reciprocally incorporated</p>
<p>Diagram 7b: A lens L (circle) contains a red triangular lenslet with a yellow dot at its center. A vertical dashed line with arrows at both ends is labeled 'A'. To the right, a curved lens with a red rectangular lenslet is shown. Labels include 'LG and F1' pointing to the lenslet, 'F2' pointing to the focal point, '2' pointing to the lens surface, and 'AA' at the bottom.</p>	<p>Not Reciprocally incorporated</p>
<p>In the case where the outer lens (textured or not) is included:</p>	
<p>Diagram 7a: A lens L (circle) contains a red triangular lenslet with a yellow dot at its center. A vertical dashed line with arrows at both ends is labeled 'A'. To the right, a curved lens with a red rectangular lenslet is shown. Labels include 'LG and F1' pointing to the lenslet, 'F2' pointing to the focal point, '2' pointing to the lens surface, and 'AA' at the bottom.</p>	<p>Reciprocally incorporated</p>
<p>Diagram 7a: A lens L (circle) contains a red triangular lenslet with a yellow dot at its center. A vertical dashed line with arrows at both ends is labeled 'A'. To the right, a curved lens with a red rectangular lenslet is shown. Labels include 'LG and F1' pointing to the lenslet, 'F2' pointing to the focal point, '2' pointing to the lens surface, and 'AA' at the bottom.</p>	<p>Reciprocally incorporated</p>

<p>In the case where the outer lens (textured or not) is included</p>	
	<p>Reciprocally incorporated</p>
<p>In the case where the non-textured outer lens is excluded, "7b" is the apparent surface according to paragraph 2.8. and F1 shall not be transparent to F2:</p>	
	<p>F1 is not reciprocally incorporated with F2</p>
<p>In the case where the non-textured outer lens is excluded or not</p>	
	<p>Reciprocally incorporated</p>

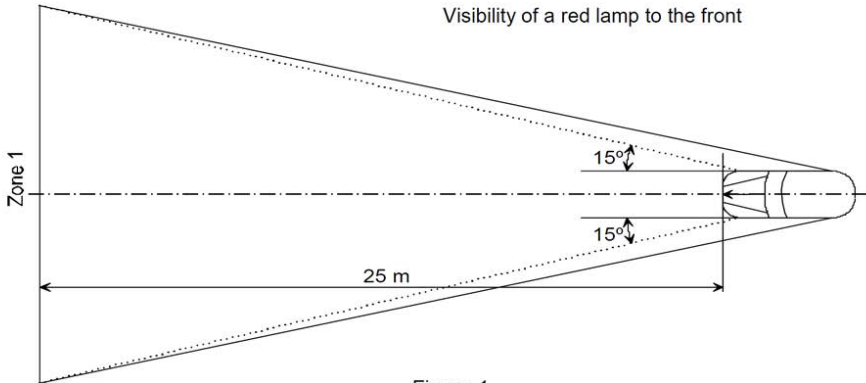
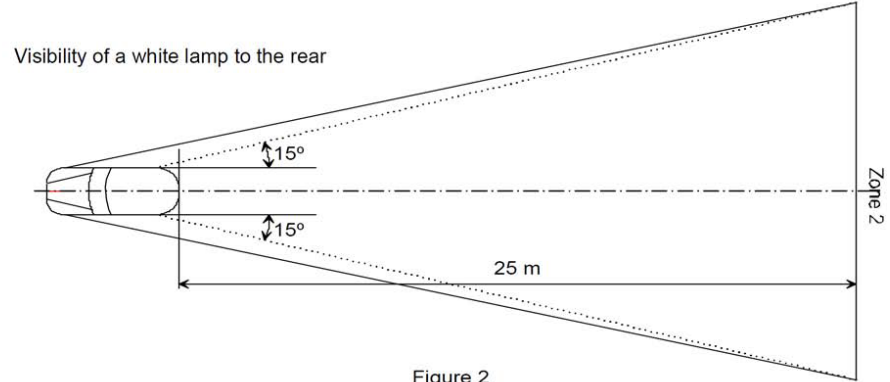
11.4	Visibility of a red lamp to the front and visibility of a white lamp to the rear (See paragraphs 5.10.1. and 5.10.2. of this Standard)
<div data-bbox="454 331 1324 712"><p>Visibility of a red lamp to the front</p><p>The diagram shows a red lamp on the right side of a vehicle. A horizontal dashed line represents the centerline. Two dotted lines extend from the lamp, forming a 30-degree angle (15 degrees above and 15 degrees below the centerline). A vertical line labeled 'Zone 1' is on the left. A horizontal double-headed arrow below the centerline indicates a distance of 25 m from the lamp to the Zone 1 line.</p></div> <p data-bbox="861 705 941 728">Figure 1</p> <div data-bbox="454 784 1348 1164"><p>Visibility of a white lamp to the rear</p><p>The diagram shows a white lamp on the left side of a vehicle. A horizontal dashed line represents the centerline. Two dotted lines extend from the lamp, forming a 30-degree angle (15 degrees above and 15 degrees below the centerline). A vertical line labeled 'Zone 2' is on the right. A horizontal double-headed arrow below the centerline indicates a distance of 25 m from the lamp to the Zone 2 line.</p></div> <p data-bbox="861 1153 941 1176">Figure 2</p>	

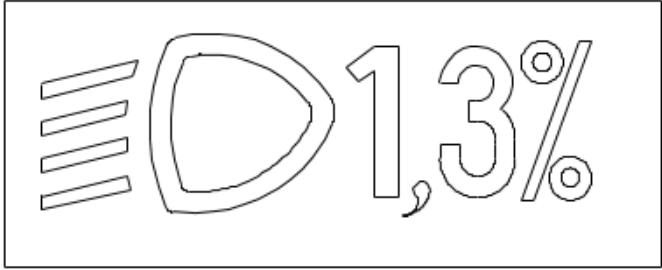
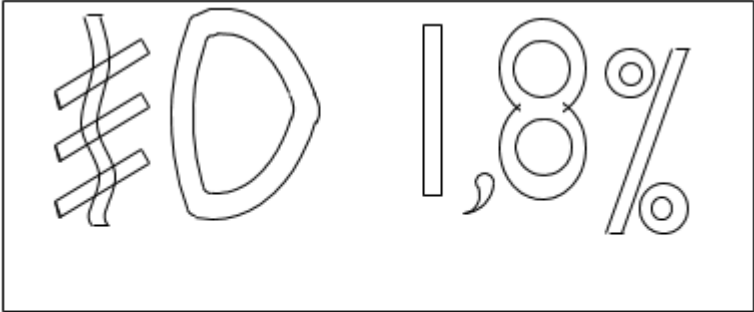
<p style="text-align: center;">ANNEX A</p> <p style="text-align: center;">Indication of the downward inclination of the dipped-beam headlamps cut-off referred to in paragraph 6.2.6.1.1. and downward inclination of the front fog lamp cut-off referred to in paragraph 6.3.6.1.2. of this Standard</p>	
<p>Example 1</p>	<p style="text-align: center;">The size of the symbol and characters is left to the discretion of the manufacturer.</p> <div style="text-align: center;"><p style="display: flex; justify-content: space-around; margin-top: 10px;">□ Standard symbol for dipped-beam headlamp□ Value of the stated initial adjustment</p></div>
<p>Example 2</p>	<p style="text-align: center;">The size of the symbol and characters is left to the discretion of the manufacturer</p> <div style="text-align: center;"><p style="display: flex; justify-content: space-around; margin-top: 10px;">□ Standard symbol for front fog lamp□ Value of the downward inclination</p></div>

ANNEX B

States of loading to be taken into consideration in determining variations in the vertical orientation of the dipped-beam headlamps

Loading conditions on axles referred to in paragraphs 6.2.6.1. and 6.2.6.3.1.

1.0 For the following tests, the mass of the passengers shall be calculated on the basis of 75 kg per person.

2.0 Loading conditions for different types of vehicles:

2.1. Vehicles in category M1

2.1.1. The angle of the light beam of the dipped-beam headlamps shall be determined under the following load conditions:

2.1.1.1. One person in the driver's seat;

2.1.1.2. The driver, plus one passenger in the front seat farthest from the driver;

2.1.1.3. The driver, one passenger in the front seat farthest from the driver, all the seats farthest to the rear occupied;

2.1.1.4. All the seats occupied;

2.1.1.5. All the seats occupied, plus an evenly distributed load in the luggage boot, in order to obtain the permissible load on the rear axle or on the front axle if the boot is at the front. If the vehicle has a front and a rear boot, the additional load shall be appropriately distributed in order to obtain the permissible axle loads. However, if the maximum permissible laden mass is obtained before the permissible load on one of the axles, the loading of the boot(s) shall be limited to the figure which enables that mass to be reached;

2.1.1.6. Driver, plus an evenly distributed load in the boot, in order to obtain the permissible load on the corresponding axle.

However, if the maximum permissible laden mass is obtained before the permissible load on the axle, the loading of the boot(s) shall be limited to the figure which enables that mass to be reached.

2.1.2. In determining the above loading conditions, account shall be taken of any loading restrictions laid down by the manufacturer.

2.2. Vehicle in categories M2 and M3

The angle of the light beam from the dipped-beam headlamps shall be determined under the following loading conditions:

2.2.1. Vehicle unladen and one person in the driver's seat;

2.2.2. Vehicles laden such that each axle carries its maximum technically permissible load or until the maximum permissible mass of the vehicle is attained by loading the front and rear axles proportionally to their maximum technically permissible loads, whichever occurs first.

2.3. Vehicles in category N with load surfaces:

2.3.1. The angle of the light beam from the dipped-beam headlamps shall be determined under the following loading conditions;

2.3.1.1. Vehicle unladen and one person in the driver's seat;

2.3.1.2. Driver, plus a load so distributed as to give the maximum technically permissible load on the rear axle or axles, or the maximum permissible mass of the vehicle, whichever occurs first, without exceeding a front axle load calculated as the sum of the front axle load of the unladen vehicle plus 25 per cent of the maximum permissible payload on the front axle. Conversely, the front axle is so considered when the load platform is at the front.

2.4. Vehicles in category N without a load surface:

2.4.1. Drawing vehicles for semi-trailers:

2.4.1.1. Unladen vehicle without a load on the coupling attachment and one person in the driver's seat;

2.4.1.2. One person in the driver's seat: technically permissible load on the coupling attachment in the position of the attachment corresponding to the highest load on the rear axle.

2.4.2. Drawing vehicles for trailers:

2.4.2.1. Vehicle unladen and one person in the driver's seat;

2.4.2.2. One person in the driver's seat, all the other places in the driving cabin being occupied.

ANNEX C

Measurement of the variation of dipped-beam inclination as a function of load**1.0 Scope**

This annex specifies a method for measuring variations in motor vehicle dipped-beam inclination, in relation to its initial inclination, caused by changes in vehicle attitude due to loading.

2.0 Definitions

2.1. Initial inclination

2.1.1. Stated initial inclination

The value of the dipped-beam initial inclination specified by the motor vehicle manufacturer serving as a reference value for the calculation of permissible variations.

2.1.2. Measured initial inclination

The mean value of dipped-beam inclination or vehicle inclination measured with the vehicle in condition No. 1, as defined in Annex B, for the category of vehicle under test. It serves as a reference value for the assessment of variations in beam inclination as the load varies.

2.2. Dipped-beam inclination

It may be defined as follows:

Either as the angle, expressed in miliradians, between the direction of the beam towards a characteristic point on the horizontal part of the cut-off in the luminous distribution of the headlamp and the horizontal plane,

Or by the tangent of that angle, expressed in percentage inclination, since the angles are small (for these small angles, 1 per cent is equal to 10 mrad).

If the inclination is expressed in percentage inclination, it can be calculated by means of the following formula:

$$\frac{(h_1 - h_2)}{L} \times 100$$

where:

h1 is the height above the ground, in millimetres, of the above- mentioned characteristic point, measured on a vertical screen perpendicular to the vehicle longitudinal median plane, placed at a horizontal distance L.

h2 is the height above the ground, in millimetres, of the centre of reference (which is taken to be the nominal origin of the characteristic point chosen in h1):

L is the distance, in millimeters, from the screen to the centre of reference. Negative values denote downward inclination (see below Figure). Positive values denote upward inclination.

Dipped-beam downward inclination of a category M1 vehicle

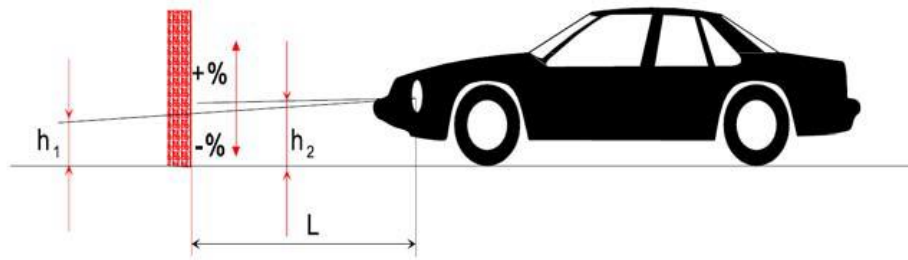

Notes :

- 1.0 This drawing represents a category M1 vehicle, but the principle shown applies equally to vehicles of other categories.
- 2.0 Where the vehicle does not incorporate a headlamp levelling system, the variation in dipped-beam inclination is identical with the variation in the inclination of the vehicle itself.

3.0 Measurement conditions

- 3.1. If a visual inspection of the dipped-beam pattern on the screen or a photometric method is used, measurement shall be carried out in a dark environment (for example, a dark room) of sufficient area to allow the vehicle and the screen to be placed as shown in figure under clause 2.2. Headlamp centres of reference shall be at a distance from the screen of at least 10 m.
- 3.2. The ground on which measurements are made shall be as flat and horizontal as possible, so that the reproducibility of measurements of dipped-beam inclination can be assured with an accuracy of ± 0.5 mrad (± 0.05 per cent inclination).
- 3.3. If a screen is used, its marking, position and orientation in relation to the ground and to the median longitudinal plane of the vehicle, shall be such that the reproducibility of the measurement of the dipped-beam inclination can be assured with an accuracy of ± 0.5 mrad (± 0.05 per cent inclination).
- 3.4. During measurements, the ambient temperature shall be between 10 and 30 °C.

4.0 Vehicle preparation

- 4.1. Measurements shall be carried out on a vehicle which has travelled a distance of between 1,000 km and 10,000 km, preferably 5,000 km.
- 4.2. Tyres shall be inflated to the full-load pressure specified by the vehicle manufacturer. The vehicle shall be fully replenished (fuel, water, oil) and equipped with all the accessories and tools specified by the manufacturer. Full fuel replenishment means that the fuel tank shall be filled to not less than 90 per cent of its capacity.
- 4.3. The vehicle shall have the parking brake released and the gearbox in neutral.

- 4.4. The vehicle shall be conditioned for at least 8 h at the temperature specified in paragraph 3.4. above.
- 4.5. If a photometric or visual method is used, headlamps with a well-defined dipped-beam cut-off should preferably be installed on the vehicle under test in order to facilitate the measurements. Other means are allowed to obtain a more precise reading (for example, removal of the headlamp lens).

5.0 Test procedure

5.1. General

The variations in either dipped-beam or vehicle inclination, depending on the method chosen, shall be measured separately for each side of the vehicle. The results obtained from both left and right headlamps under all the load conditions specified in Annex B, shall be within the limits set out in paragraph 5.5. below. The load shall be applied gradually without subjecting the vehicle to excessive shocks.

- 5.1.1. Where an AFS is fitted, the measurements shall be carried out with the AFS in its neutral state.

5.2. Determination of the measured initial inclination

The vehicle shall be prepared as specified in paragraph 4. above and laden as specified in Annex B (first loading condition of the respective vehicle category). Before each measurement, the vehicle shall be rocked as specified in paragraph 5.4. below. Measurements shall be made three times.

- 5.2.1. If none of the three measured results differ by more than 2 mrad (0.2 per cent inclination) from the arithmetic mean of the results, that mean shall constitute the final result.
- 5.2.2. If any measurement differs from the arithmetic mean of the results by more than 2 mrad (0.2 per cent inclination), a further series of 10 measurements shall be made, the arithmetic mean of which shall constitute the final result.

5.3. Measurement methods

Any method may be used to measure variations of inclination provided that the readings are accurate to within ± 0.2 mrad (± 0.02 per cent inclination).

5.4. Treatment of vehicle in each loading condition

The vehicle suspension and any other part likely to affect dipped-beam inclination shall be activated according to the methods described below.

However, the technical authorities and manufacturers may jointly propose other methods (either experimental or based upon calculations), especially when the test poses particular problems, provided such calculations are clearly valid.

5.4.1. M1 category vehicles with conventional suspension

With the vehicle standing on the measuring site and, if necessary, with the wheels resting on floating platforms (which shall be used if their absence would lead to restriction of the suspension movement likely to affect the results of measurements), rock the vehicle

continuously for at least three complete cycles, for each cycle, first the rear and then the front end of the vehicle is pushed down.

The rocking sequence shall end with the completion of a cycle. Before making the measurements, the vehicle shall be allowed to come to rest spontaneously. Instead of using floating platforms, the same effect can be achieved by moving the vehicle backwards and forwards for at least a complete wheel revolution.

5.4.2. M2, M3 and N category vehicles with conventional suspension

5.4.2.1. If the treatment method for category M1 vehicles described in paragraph 5.4.1. is not possible, the method described in paragraphs 5.4.2.2. or 5.4.2.3. may be used.

5.4.2.2. With the vehicle standing on the measuring site and the wheels on the ground, rock the vehicle by temporarily varying the load.

5.4.2.3. With the vehicle standing on the measuring site and the wheels on the ground, activate the vehicle suspension and all other parts which may affect the dipped-beam inclination by using a vibration rig. This can be a vibrating platform on which the wheels rest.

5.4.3. Vehicles with non-conventional suspension, where the engine has to be running.

Before making any measurement wait until the vehicle has assumed its final attitude with the engine running.

5.5. Measurements

The variation of the inclination of the dipped-beam shall be assessed for each of the different loading conditions in relation to the measured initial inclination determined in accordance with paragraph 5.2. above.

If the vehicle is fitted with a manual headlamp-levelling system, the latter shall be adjusted to the positions specified by the manufacturer for given loading conditions (according to Annex B).

5.5.1. To begin with, a single measurement shall be made in each loading condition.

Requirements have been met if, for all the loading conditions, the variation in inclination is within the calculated limits (for example, within the difference between the stated initial inclination and the lower and upper limits specified for approval) with a safety margin of 4 mrad (0.4 per cent inclination).

- 5.5.2. If the result(s) of any measurement(s) does (do) not lie within the safety margin indicated in paragraph 5.5.1. or exceed(s) the limit values, a further three measurements shall be made in the loading conditions corresponding to this (these) result(s) as specified in paragraph 5.5.3.
- 5.5.3. For each of the above loading conditions:
- 5.5.3.1. If none of the three measured results differs by more than 2 mrad (0.2 per cent inclination) from the arithmetic mean of the results, that mean shall constitute the final result.
- 5.5.3.2. If any measurement differs from the arithmetic mean of the results by more than 2 mrad (0.2 per cent inclination), a further series of 10 measurements shall be made, the arithmetic mean of which shall constitute the final result.
- 5.5.3.3. If a vehicle is fitted with an automatic headlamp-levelling system which has an inherent hysteresis loop, average results at the top and bottom of the hysteresis loop shall be taken as significant values.
- All these measurements shall be made in accordance with paragraphs 5.5.3.1. and 5.5.3.2.
- 5.5.4. Requirements have been met, if, under all loading conditions, the variation between the measured initial inclination determined in accordance with paragraph 5.2. and the inclination measured under each loading condition is less than the values calculated in paragraph 5.5.1. (Without safety margin).
- 5.5.5. If only one of the calculated upper or lower limits of variation is exceeded, the manufacturer shall be permitted to choose a different value for the stated initial inclination, within the limits specified for approval.

ANNEX D

The controls for the headlamp-levelling devices

1.0 Specifications

- 1.1. Downward inclination of the dipped-beam shall in all cases be produced in one of the following ways:
- (a) By moving a control downwards or to the left;
 - (b) By rotating a control in a counter clockwise direction;
 - (c) By depressing a button (push-pull control).

If several buttons are used to adjust the beam, the button which gives the greatest downward inclination shall be installed to the left or below the button(s) for other dipped-beam positions.

A rotary control which is installed edge-on, or with only the edge visible, should follow the operating principles of control of types (a) or (c).

- 1.1.1. This control shall carry symbols indicating clearly the movements corresponding to the downward and upward inclination of the dipped-beam.
- 1.2. The "0" position corresponds to the initial inclination according to paragraph 6.2.6.1.1. of this Regulation.
- 1.3. The "0" position which, according to paragraph 6.2.6.2.2. of this Regulation has to be a "Stop position", need not necessarily be at the end of the scale.
- 1.4. The marks used on control shall be explained in the owner's handbook.
- 1.5. Only the following symbols may be used to identify the controls:

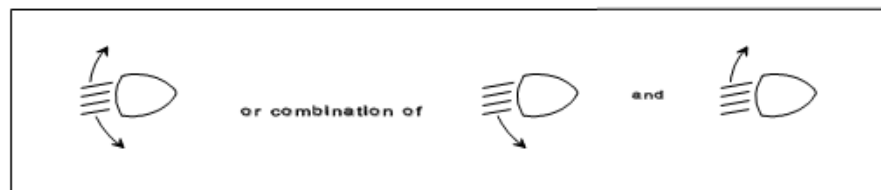

Symbols employing five lines instead of four may also be used

Example 1

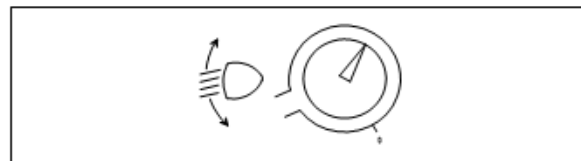

Example 2

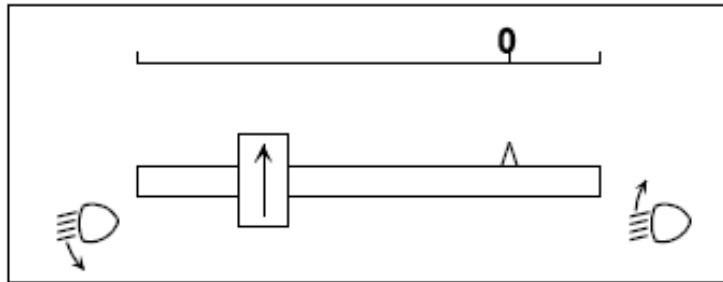

Example 3

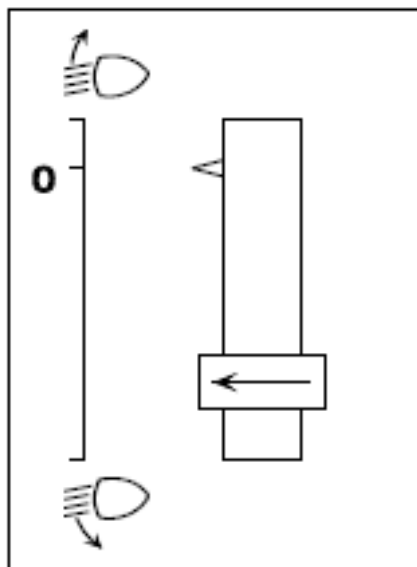

ANNEX E

Examples of light source options

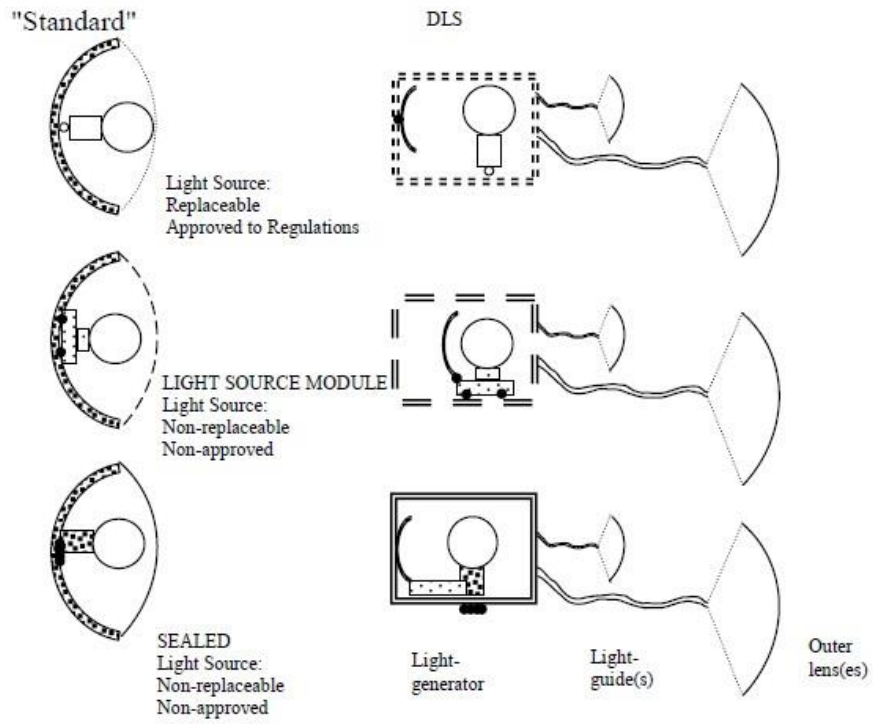

ANNEX F
Visibility of conspicuity markings to the rear, front and side of a vehicle
 (see paragraph 6.21.5. of this Standard)

Figure 1a : Rear

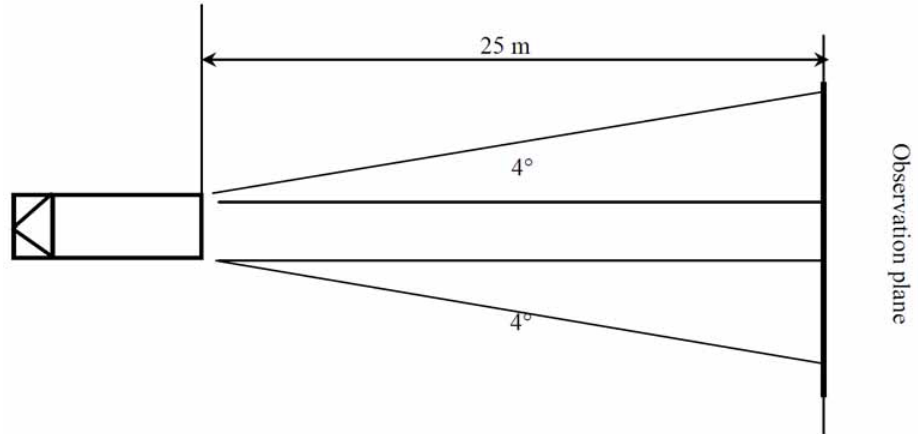

Figure 1b : Front (Trailers only)

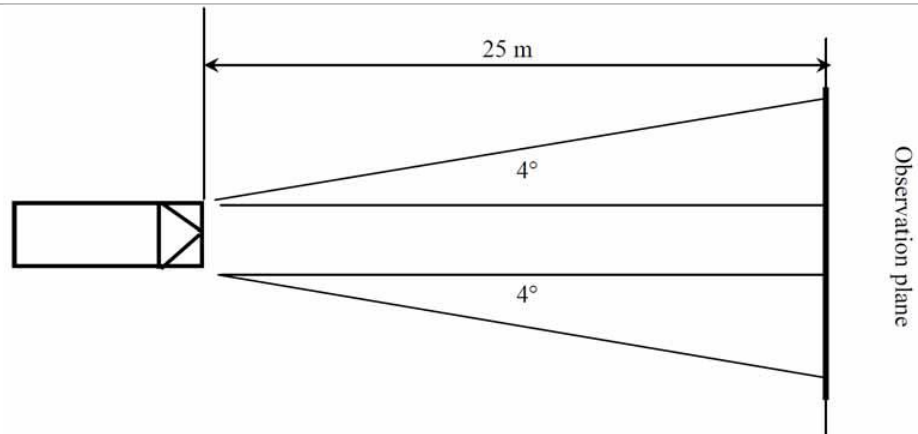
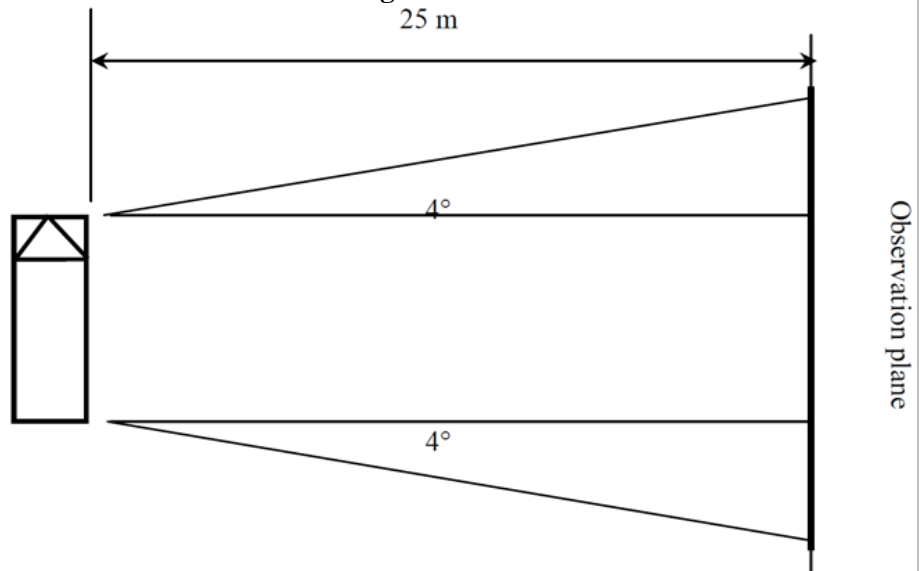

Figure 2 : Side



ANNEX G

Test drive**1.0 Test drive specifications for the automatic control of the main-beam headlamps**

- 1.1 The test drive shall be carried out in clear atmosphere and with clean headlamps
- 1.2 The test course shall comprise test sections with traffic conditions, at speed corresponding to the relevant type of road, as described in Table 1 below:

Table 1				
Test Section	Traffic conditions	Road type		
		Urban areas	Multi-lane road, e.g. motor way	Country road
	Speed	50 ± 10 km/h	100 ± 20 km/h	80 ± 20 km/h
	Average percentage of the full test course length	10 per cent	20 per cent	70 per cent
A	Single oncoming vehicle or single preceding vehicle in a frequency so that the main beam will switch ON and OFF.		X	X
B	Combined oncoming and preceding traffic situations, in a frequency so that the main beam will switch ON and OFF.		X	X
C	Active and passive overtaking manoeuvres, in a frequency so that the main beam will switch ON and OFF.		X	X
D	Oncoming bicycle, as described in paragraph 6.1.9.3.1.2.			X
E	Combined oncoming and preceding traffic situations	X		

- 1.3. Urban areas shall comprise roads with and without illumination.
- 1.4. Country roads shall comprise sections having two lanes and sections having four or more lanes and shall include junctions, hills and/or slopes, dips and winding roads.
- 1.5. Multi-lane roads (e.g. motorways) and country roads shall comprise sections having straight level parts with a length of more than 600 m. additionally they shall comprise sections having curves to the left and to the right.
- 1.6. Dense traffic situations shall be taken into account."

2.0 Test drive specifications for adaptive main-beam headlamps

- 2.1. The test drive shall be carried out in clear atmosphere and with clean headlamps.
- 2.2. The test course shall comprise test sections with traffic conditions, at speed corresponding to the relevant type of road, as described in table 2 below:

Table 2				
Test Section	Traffic conditions	Road type		
		Urban areas	Multi-lane road, e.g. motor way	Country road
	Speed	50 ± 10km/h	100 ± 20km/h	80 ± 20km/h
Average percentage of the full test course length	10 per cent	20 per cent	70 per cent	
A	Single oncoming vehicle or single preceding vehicle in a frequency so that the adaptive main beam will react to demonstrate the adaptation process.		X	X
B	Combined oncoming and preceding traffic situations. in a frequency so that the adaptive main beam will react to demonstrate the adaptation process.		X	X
C	Active and passive overtaking manoeuvres, in a frequency so that the adaptive main beam will react to demonstrate the adaptation process.		X	X
D	Oncoming bicycle, as described in paragraph 6.22.9.3.1.2.			X
E	Combined oncoming and preceding traffic situations	X		

- 2.3. Urban areas shall comprise roads with and without illumination.
- 2.4. Country roads shall comprise sections having two lanes and sections having four or more lanes and shall include junctions, hills and/or slopes, dips and winding roads.
- 2.5. Multilane roads (e.g. motorways) and country roads shall comprise sections having straight level parts with a length of more than 600 m. Additionally they shall comprise of sections having curves to the left and to the right.
- 2.6. Dense traffic situations shall be taken into account
- 2.7. For the test sections A and B in the table above the engineers conducting the tests shall evaluate and record the acceptability of the performance of the adaptation process in relation to oncoming and preceding road users. This means that the test engineers shall be seated in the vehicle being tested and additionally be seated in the oncoming and preceding vehicles.

ANNEX H

Automatic switching conditions dipped-beam headlamps

Automatic switching conditions dipped-beam headlamps ¹		
Ambient light outside the vehicle²	Dipped-beam headlamps	Response time
less than 1,000 lux	ON	no more than 2 seconds
between 1,000 lux and 7,000 lux	at manufacturer's discretion	at manufacturer's discretion
more than 7,000 lux	OFF	more than 5 seconds, but no more than 300 seconds

- 1 Compliance with these conditions shall be demonstrated by the applicant, by simulation or other means of verification accepted by the test agency responsible for type approval.
- 2 The illuminance shall be measured on a horizontal surface, with a cosine corrected sensor on the same height as the mounting position of the sensor on the vehicle. This may be demonstrated by the manufacturer by sufficient documentation or by other means accepted by the test agency responsible for type approval.

ANNEX I

Observing area towards the apparent surface of maneuvering and Courtesy lamps

Zones of observation

This drawing shows the zone from one side, the other zones are from the front, the rear and from the other side of the vehicle

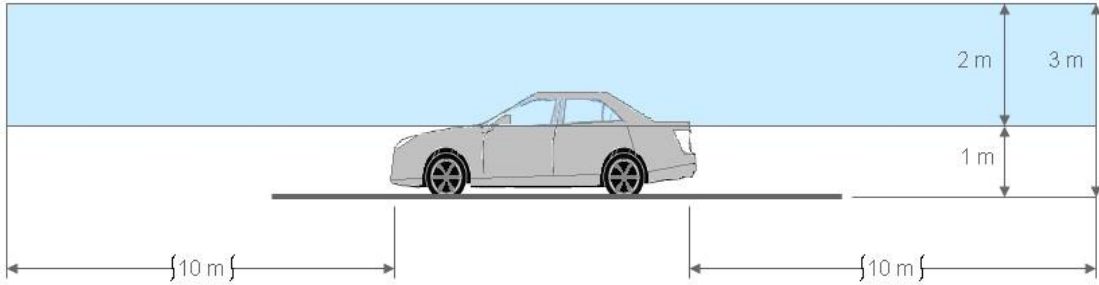

Boundaries of the zones

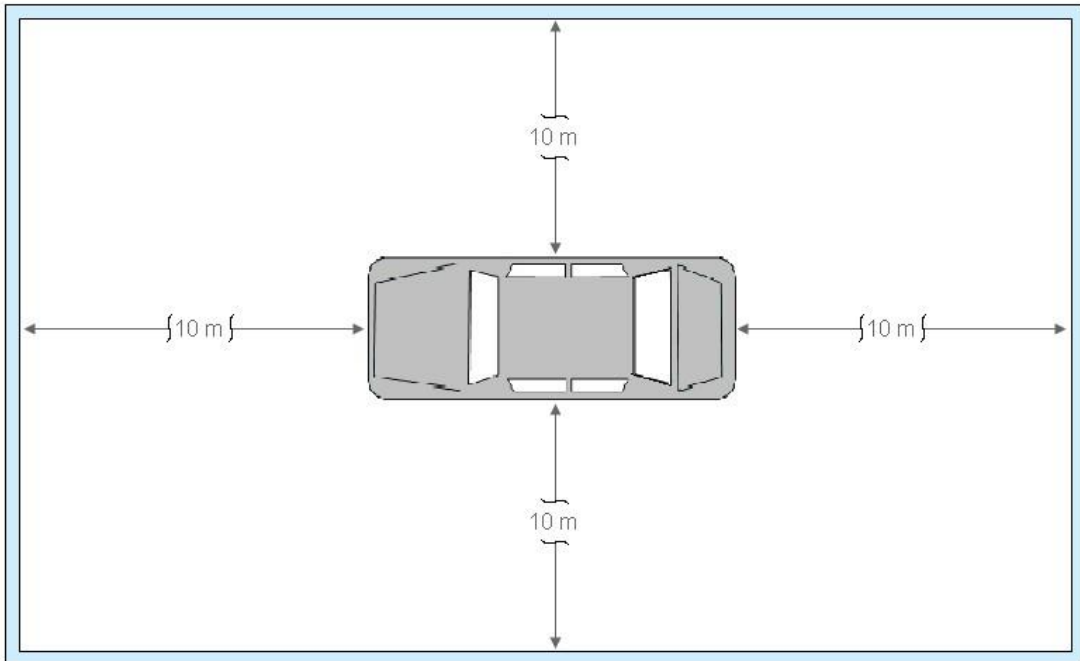

ANNEX J

Gonio (photo) meter system used for the photometric measurements as defined in paragraph 2.34. of this Standard:

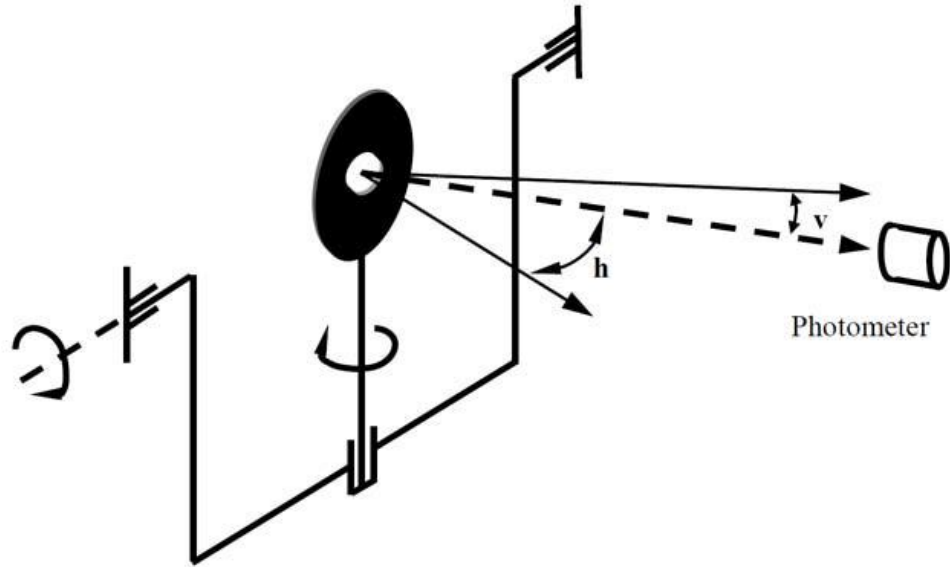

ANNEX K

Guidelines for installation of rear marking plates on heavy and long vehicles

1.0 It is recommended to apply on vehicles specified in paragraph 2 of this Annex "Rear marking plates for heavy and long vehicles" conforming to AIS-089 standard and the specific requirements relating to its scope in accordance with the guidelines given in this Annex.

2.0 SCOPE

The main purpose of these guidelines is to establish requirements for Installation, arrangement, position and geometric visibility of rear marking plates on heavy and long vehicles. It increases the visibility and permits an easy identification of these vehicles.

2.1. Heavy Motor Vehicles

The installation of rear marking plates for heavy motor vehicles according to the provisions of this Annex is required for vehicles of Category N2, with a maximum mass exceeding 7.5 tonnes and N3, with the exception of tractors for semi-trailers and for articulated buses.

2.2. Long Vehicles

The installation of rear marking plates for long vehicles, according to the provisions of this Annex, is required for the following vehicles:

Categories T1, T2, T3 – trailers/semi-trailers exceeding 8 m in length (including the drawbar).

All vehicles of Category T4.

3.0 NUMBER

3.1 One, two, or four.

3.2 Where rear marking plates conforming to AIS-089 are installed these may be considered, at the discretion of the manufacturer, as part of the conspicuity marking to the rear as referred in clause 7.4 of Annex 7 of AIS-090, for the purposes of calculating the length of the conspicuity marking and its proximity to the side of the vehicle.

3.3. Where rear conspicuity markings conforming to AIS-090 is installed, the vehicle, except for trailers and semi-trailers of length exceeding 8m and vehicles conforming to clause 1.2.3 of Annex 7 of AIS-090, shall be deemed to have complied with the requirements of rear marking plates as per AIS-089.

4.0 ARRANGEMENT

Every rear marking shall be fitted such that the lower edge is horizontal.

Every part of a rear marking shall lie within 5° of a transverse vertical Plane at right angles to the longitudinal axis of the vehicle and shall face to the rear. The set of marking plates shall be arranged symmetrically with respect to the median longitudinal plane of the vehicle.

The rear marking plates shall be type approved and meet the requirements of this standard with the following classification.

(a) For heavy vehicles:

Class 1	alternate, oblique stripes of red fluorescent and yellow retro-reflective materials;
Class 3	alternate, oblique stripes of red retro-reflective and yellow retro-reflective materials.

(b) For long vehicles:

Class 2	yellow retro-reflective centre with a red fluorescent border;
Class 4	yellow retro-reflective centre with a red retro-reflective border.

5.0. POSITION

In width: No individual specifications.

In height: Above the ground, not less than 250 mm (lower edge), nor more than 2,100 mm (upper edge).

6.0 GEOMETRIC VISIBILITY

Horizontal angle : 30° inwards and outwards

Vertical angle : 15° above and below the horizontal

Orientation: rearwards.

ANNEX L	
(SEE INTRODUCTION)	
COMPOSITION OF AISC PANEL	
Name	Organization
Mr. Rajendra Khile (Convenor)	Renault Nissan Technology (SIAM)
Members	Representing
Mr. B V Shamsundara/ Mrs. Jyoti M Kirve/ Mr. Kamalesh B Patil	ARAI
Mr. V. D. Chavan/ Ms. Shubhangi Dalvi	CIRT
Dr. Madhusudan Joshi/ Mr. Mahendra Pal	ICAT
Dr. N. Karuppaiah/ Mr.P. K. Banerjee	NATRIP Society of Indian Automobile Manufacturers (SIAM)
Mr. P. S.Gowrishankar / Mr. Dharmaraj Patil	Tata Motors (SIAM)
Mr. Sumit Sharma/ Mr. Gururaj Ravi	Maruti Suzuki (SIAM)
Mr. Nikhil Desai	Mercedes Benz India Ltd. (SIAM)
Mr. Karuppasamy Thangaraj	Honda Cars India Ltd. R&D (SIAM)
Mr. Jebin Jowhar	Renault Nissan Technology (SIAM)
Mr. G M Dinesh	Toyota Kirloskar Motor Pvt. Ltd. (SIAM)
Ms. Suchismita Chatterjee	Ashok Leyland Ltd. (SIAM)
Mr. Shailesh Kulkarni	Mahindra & Mahindra (SIAM)
Mr. V G Kulkarni	Mahindra Truck & Bus Division (SIAM)
Mr. Dharmendra Singh	BMW India (SIAM)
Mr. T. M. Balaraman/ Mr. Piyush Chowdhry Mr. Feroz Khan	Hero MotoCorp (SIAM)
Mr. Alaudin Ali	JLRIL (SIAM)
Mr. Arvind Kumbhar	Bajaj Auto (SIAM)
Mr. Girish Kodolikar	Force Motors Ltd. (SIAM)
Mr. Vikrant Lokhande	Volvo Trucks (SIAM)
Mr. Uday Harite	Automotive Component Manufacturers Association

	(ACMA)
Mr. G. V. George	FIEM Industries Ltd. (ACMA)
Mr. Sandeep Sharma	Minda Industries (ACMA)
Mr. Rama Shankar Pandey	Hella (ACMA)
Mr. Virendra Sachdev	Lumax Industries Ltd. (ACMA)
Mr. Arvind Vaswani	OSRAM India Limited (ACMA)
Mr. Ashish Agrawal	3M India (ACMA)

ANNEX M
(See Introduction)
COMMITTEE COMPOSITION *
Automotive Industry Standards Committee

Chairperson	
Mrs. Rashmi Urdhwareshe	Director The Automotive Research Association of India, Pune
Members	Representing
Representative from	Ministry of Road Transport and Highways (Dept. of Road Transport and Highways), New Delhi
Representative from	Ministry of Heavy Industries and Public Enterprises (Department of Heavy Industry), New Delhi
Shri S. M. Ahuja	Office of the Development Commissioner, MSME, Ministry of Micro, Small and Medium Enterprises, New Delhi
Shri Shrikant R. Marathe	Former Chairman, AISC
Shri R.R. Singh	Bureau of Indian Standards, New Delhi
Director	Central Institute of Road Transport, Pune
Director	Global Automotive Research Centre
Director	International Centre for Automotive Technology, Manesar
Director	Indian Institute of Petroleum, Dehra Dun
Director	Indian Rubber Manufacturers Research Association
Director	Vehicles Research and Development Establishment, Ahmednagar
Representatives from	Society of Indian Automobile Manufacturers
Shri R. P. Vasudevan	Tractor Manufacturers Association, New Delhi
Shri Uday Harite	Automotive Components Manufacturers Association of India, New Delhi

Member Secretary
Shri Vikram Tandon
Dy. General Manager
The Automotive Research Association of India, Pune

* At the time of approval of this Automotive Industry Standard (AIS)