

**Amendment No. 4 (07/2023)**

to

**AIS-137 (Part 2): Test Method, Testing Equipment and Related Procedures for Type Approval and Conformity of Production (COP) Testing of L5 Category Vehicles for Bharat Stage VI (BS VI) Emission Norms as per CMV Rules 115, 116 and 126**

**1.0 APPNEDIX 1 TO CHAPTER 7 , Clause 1.1.5.2**

Substitute following text for existing text:

- 1.1.5.2. The functionality and integrity of the particulate trap, where fitted. (Exempted for Particulate Trap with open loop system for OBD-II Stage A)”

**2.0 CHAPTER 7, Appendix 6**

Add following new clause 4.3 after clause 4.2:

- 4.3 If the fluid used is “Water without any additive”, requirement of clause 4.2 shall not be applicable.

**3.0 CHAPTER 7, Appendix 6, Clause 5.4, 5.5 and 8.4**

Substitute following text for existing text:

- 5.4 A deviation of more than 50% between the average consumable fluid consumption and the average demanded consumable fluid consumption by the engine system over a period of 30 to 120 minutes of vehicle operation, shall result in the activation of the driver warning system in clause 3 of this Chapter, which shall display a message indicating an appropriate warning (e.g. " consumable fluid injection malfunction", " fluid injection malfunction"). If the consumable fluid consumption is not rectified within 50 km or 120 minutes of the activation of the warning system then the driver inducement requirements of clause 8 shall apply.
- 5.5 In the case of interruption in consumable fluid injection activity the driver warning system as referred to in clause 3 of this Chapter shall be activated, which shall display a message indicating an appropriate warning. This activation shall not be required where the interruption is demanded by the engine ECU because the vehicle operating conditions are such that the vehicle's emission performance does not require consumable fluid injection, provided that the manufacturer has clearly informed the Test Agency when such operating conditions apply. If the consumable fluid injection is not rectified within 50 km or 120 minutes of the activation of the warning system

then the driver inducement requirements of clause 8 of this Chapter shall apply.

- 8.4. Once the inducement system has fully activated and disabled the vehicle, the inducement system shall only be deactivated if the quantity of consumable fluid added to the vehicle is equivalent to 250 km average driving range, or the failures specified in clauses 4., 5. of this Chapter have been rectified. After a repair has been carried out to correct a fault where the OBD system has been triggered under clause 7.2 of this Chapter, the inducement system may be reinitialized via the OBD serial port (e.g. by a generic scan tool) to enable the vehicle to be restarted for self-diagnosis purposes. The vehicle shall operate for a maximum of 50 km or 120 minutes to enable the success of the repair to be validated. The inducement system shall be fully reactivated if the fault persists after this validation.

PRINTED BY  
THE AUTOMOTIVE RESEARCH ASSOCIATION OF INDIA  
P.B. NO. 832, PUNE 411 004  
ON BEHALF OF  
AUTOMOTIVE INDUSTRY STANDARDS COMMITTEE  
UNDER  
CENTRAL MOTOR VEHICLE RULES – TECHNICAL STANDING COMMITTEE  
SET-UP BY  
MINISTRY OF ROAD TRANSPORT & HIGHWAYS  
(DEPARTMENT OF ROAD TRANSPORT & HIGHWAYS)  
GOVERNMENT OF INDIA  
13<sup>th</sup> July 2023

**Amendment No. 3 (11/2022)**

to

**AIS-137 (Part 2): Test Method, Testing Equipment and Related Procedures  
for Type Approval and Conformity of Production (COP) Testing of L5  
Category Vehicles for Bharat Stage VI (BS VI) Emission Norms as per CMV  
Rules 115, 116 and 126**

**1.0 Chapter 1, Page No. 13/38,**

Add following new clause 1.1.5.7 after clause 1.1.5.6 :

1.1.5.7 For the vehicles, that rely on the use of a consumable fluid (other than reagent used for after treatment systems) stored in a separate container / tank in order to reduce emissions, monitoring for malfunctions w.r.t. fluid quantity ( Low level & tank empty) and the dosing / injecting subsystem shall be required.

The system shall be designed as to meet the requirements as detailed in Appendix 6 of Chapter 7 of this Part.

**2.0 Chapter 7**

Add following new appendix 6 after Appendix 5

**CHAPTER 7: Appendix 6:**

**REQUIREMENTS FOR VEHICLES THAT USE A CONSUMABLE  
FLUID IN A SEPARATE TANK OR CONTAINER FOR EMISSION  
REDUCTION**

**1.0 INTRODUCTION**

This Appendix sets out the requirements for vehicles that rely on the use of a consumable fluid (other than reagent used for after treatment systems) stored in a separate container / tank in order to reduce emissions. For the purpose of this chapter, the “consumable fluid” implies a fluid other than the reagent used for after treatment systems.

**2.0 FLUID INDICATION**

2.1. The vehicle shall include a specific level indicator (analogue / digital) on the dashboard that informs the driver of low levels of consumable fluid in the storage tank and of when the consumable fluid tank becomes empty.

**3.0 DRIVER WARNING SYSTEM**

3.1. The vehicle shall include a warning system consisting of visual indication (Tell-tale indications) and / or audio alarms that informs

the driver when the consumable fluid level is low, that the tank soon needs to be refilled.

- 3.2. The warning system shall escalate in intensity as the consumable fluid approaches empty. It shall culminate in a driver notification that cannot be easily defeated or ignored. It shall not be possible to turn off the system until the consumable fluid has been replenished.

If tell-tale is given in the form of low-level indication lamp and adequate instructions for drives, considered to be allowed.

- 3.3. The visual warning shall display a message indicating a low level of consumable fluid. The warning shall not be the same as the warning used for the purposes of OBD or other engine maintenance. The warning shall be sufficiently clear for the driver to understand that the consumable fluid level is low (e.g. " consumable fluid low", "Fluid level low". )

- 3.4. The warning system shall activate at a distance equivalent to a driving range of at least before 20% of tank empty in advance of the consumable fluid tank becoming empty.

#### **4.0. IDENTIFICATION OF INCORRECT CONSUMABLE FLUID**

- 4.1. The vehicle shall include a means of determining that a consumable fluid corresponding to the characteristics declared by the manufacturer and recorded in AIS- 007, as amended from time to time, is present on the vehicle.

- 4.2. If the consumable fluid in the storage tank does not correspond to the requirements/specifications declared by the manufacturer, the driver warning system in clause 3 of this Chapter shall be activated and shall display a message indicating an appropriate warning (e.g. "incorrect consumable fluid detected", "incorrect fluid detected "). If the consumable fluid quality is not rectified within 50 km of the activation of the warning system then the driver inducement requirements of clause 8 of this Chapter shall apply.

#### **5.0. CONSUMABLE FLUID CONSUMPTION MONITORING**

- 5.1. The vehicle shall include a means of determining consumable fluid consumption and providing off-board access to consumption information.

- 5.2. Average consumable fluid consumption and average demanded consumable fluid consumption by the engine system shall be available via the serial port of the standard diagnostic connector. Data shall be available over the previous engine run time hours period of vehicle operation.

- 5.3. In order to monitor consumable fluid consumption, at least the following parameters within the vehicle shall be monitored:

(a) The level of consumable fluid in the on-vehicle storage tank;

(b) The pressure of consumable fluid as close as technically possible to the point of injection.

5.4. A deviation of more than 50% between the average consumable fluid consumption and the average demanded consumable fluid consumption by the engine system over a period of 30 minutes of vehicle operation, shall result in the activation of the driver warning system in clause 3 of this Chapter, which shall display a message indicating an appropriate warning (e.g. " consumable fluid injection malfunction", " fluid injection malfunction"). If the consumable fluid consumption is not rectified within 50 km of the activation of the warning system then the driver inducement requirements of clause 8 shall apply.

5.5. In the case of interruption in consumable fluid injection activity the driver warning system as referred to in clause 3 of this Chapter shall be activated, which shall display a message indicating an appropriate warning. This activation shall not be required where the interruption is demanded by the engine ECU because the vehicle operating conditions are such that the vehicle's emission performance does not require consumable fluid injection, provided that the manufacturer has clearly informed the Test Agency when such operating conditions apply. If the consumable fluid injection is not rectified within 50 km of the activation of the warning system then the driver inducement requirements of clause 8 of this Chapter shall apply.

## **6.0. RESERVED**

## **7.0. STORAGE OF FAILURE INFORMATION**

7.1. Where reference is made to this clause, a non-erasable Parameter Identifier (PID) shall be stored identifying the reason for and the distance travelled by the vehicle during the inducement system activation. The vehicle shall retain a record of the PID for at least 175 days or 6500 km of vehicle operation. The PID shall be made available via the serial port of a standard diagnostic connector upon request of a generic scan tool according to the provision of clause 3.12 of Appendix 2 of Chapter 7 of this Part. The information stored in the PID shall be linked to the period of cumulated vehicle operation, during which it has occurred, with an accuracy of not less than 65 days or 2100 km.

7.2. Malfunctions in the consumable fluid injection system attributed to technical failures (e.g. mechanical or electrical faults) shall also be subject to the OBD requirements in Chapter 7 of this Part.

## **8.0. DRIVER INDUCEMENT SYSTEM**

8.1. The vehicle shall include a driver inducement system to ensure that the vehicle operates with a functioning emissions control system at all times. The inducement system shall be designed so as to ensure that the vehicle cannot operate with an empty consumable fluid tank.

- 8.2. The inducement system shall activate at the latest when the level of consumable fluid in the tank reaches a level equivalent to the average driving range of the vehicle with a complete tank of fuel. The system shall also activate when the failures in Clauses 4., 5. of this Chapter have occurred. The detection of an empty consumable fluid tank and the failures mentioned in clauses 4., 5 of this Chapter shall result in the failure information storage requirements of clause 7. of this Chapter coming into effect.
- 8.3. The manufacturer shall select which type of inducement system to install. The options for a system are described in clauses 8.3.1, 8.3.2, 8.3.3 and 8.3.4. below.
- 8.3.1 A "no engine restart after countdown" approach allows a countdown of restarts or distance remaining once the inducement system activates. Engine starts initiated by the vehicle control system, such as start-stop systems, are not included in this countdown. Engine restarts shall be prevented immediately after the consumable fluid tank becomes empty or a distance equivalent to a complete tank of fuel has been exceeded since the activation of the inducement system, whichever occurs earlier.
- 8.3.2 A "no start after refueling" system results in a vehicle being unable to start after re-fueling if the inducement system has activated.
- 8.3.3 A "fuel-lockout" approach prevents the vehicle from being refuelled by locking the fuel filler system after the inducement system activates. The lockout system shall be robust to prevent it being tampered with.
- 8.3.4. A "performance restriction" approach restricts the speed of the vehicle after the inducement system activates. The level of speed limitation shall be noticeable to the driver and significantly reduce the maximum speed of the vehicle. Such limitation shall enter into operation gradually or after an engine start. Shortly before engine restarts are prevented, the speed of the vehicle shall not exceed 50 km/h. Engine restarts shall be prevented immediately after the consumable fluid tank becomes empty or a distance equivalent to a complete tank of fuel has been exceeded since the activation of inducement system, whichever occurs earlier.
- 8.4. Once the inducement system has fully activated and disabled the vehicle, the inducement system shall only be deactivated if the quantity of consumable fluid added to the vehicle is equivalent to 250 km average driving range, or the failures specified in clauses 4., 5. of this Chapter have been rectified. After a repair has been carried out to correct a fault where the OBD system has been triggered under clause 7.2 of this Chapter, the inducement system may be reinitialized via the OBD serial port (e.g. by a generic scan tool) to enable the vehicle to be restarted for self-diagnosis purposes. The vehicle shall operate for a maximum of 50 km to enable the success of the repair to be validated. The inducement system shall be fully reactivated if the fault persists after this validation.
- 8.5. The driver warning system referred to in clause 3 of this Chapter shall display a message indicating clearly either (a) or (b).:

(a) The number of remaining restarts and/or the remaining distance;  
and

(b) The conditions under which the vehicle can be restarted.

8.6. The driver inducement system shall be deactivated when the conditions for its activation have ceased to exist. The driver inducement system shall not be automatically deactivated without the reason for its activation having been remedied.

8.7. Detailed written information fully describing the functional operation characteristics of the driver inducement system shall be provided to the Test Agency at the time of approval.

8.8. As part of the application for type approval under this Part, the manufacturer shall demonstrate the operation of the driver warning and inducement systems

## **9.0. INFORMATION REQUIREMENTS**

9.1. The manufacturer shall provide all owners of new vehicles written information about the emission control system. This information shall state that if the vehicle emission control system is not functioning correctly, the driver shall be informed of a problem by the driver warning system and that the driver inducement system shall consequentially result in the vehicle being unable to start.

9.2. The instructions shall indicate requirements for the proper use and maintenance of vehicles, including the proper use of consumable fluid.

9.3. The instructions shall specify if consumable fluid have to be refilled by the vehicle operator between normal maintenance intervals. They shall indicate how the driver should refill the consumable fluid tank. The information shall also indicate a likely rate of consumable fluid consumption for that type of vehicle and how often it should be replenished.

9.4. The instructions shall specify that use of, and refilling of, a required consumable fluid of the correct specifications is mandatory for the vehicle to comply with the certificate of conformity issued for that vehicle type.

9.5. The instructions shall state that it may be a criminal offence to use a vehicle that does not consume any consumable fluid if it is required for the reduction of emissions.

9.6. The instructions shall explain how the warning system and driver inducement systems work. In addition, the consequences of ignoring the warning system and not replenishing the consumable fluid shall be explained.

## **10.0 OPERATING CONDITIONS**

Manufacturers shall ensure that the emission control system retains its emission control function during all ambient conditions above zero deg. The manufacturer may use a heated or a non-heated consumable fluid tank and injecting system. OBD system shall monitor consumable fluid injection if ambient temperature > 5 Deg. C.

PRINTED BY  
THE AUTOMOTIVE RESEARCH ASSOCIATION OF INDIA  
P.B. NO. 832, PUNE 411 004  
ON BEHALF OF  
AUTOMOTIVE INDUSTRY STANDARDS COMMITTEE  
UNDER  
CENTRAL MOTOR VEHICLE RULES – TECHNICAL STANDING COMMITTEE  
SET-UP BY  
MINISTRY OF ROAD TRANSPORT & HIGHWAYS  
(DEPARTMENT OF ROAD TRANSPORT & HIGHWAYS)  
GOVERNMENT OF INDIA  
30<sup>th</sup> November 2022



**Amd 2 (07/2022)**  
**To**  
**AIS-137 (Part 2): Test Method, Testing Equipment and Related Procedures**  
**for Type Approval and Conformity of Production (COP) Testing of L5**  
**Category Vehicles for Bharat Stage VI (BS VI) Emission Norms as per CMV**  
**Rules 115, 116 and 126**

**1.0 Chapter 1, Clause 3.6.10**

Substitute following text for existing text:

**‘Flex fuel ethanol vehicle’** means a flex fuel vehicle that can run on petrol or a mixture of petrol and ethanol up to an 20/85/100 per cent ethanol blend (E20/E85/E100);

**2.0 Chapter 1, Clause 4.4**

Delete the following text :

This method can be used to verify specific performance parameter against that claimed by the manufacturers, as required for statutory purposes as part of type approval.

**3.0 Chapter 1, Table 1**

Substitute the existing text for following text :

**Table 1**  
**Application of Test Requirements for Type-Approval: BS-VI**

Reference Fuel	Vehicles with Positive Ignition Engines including Hybrids						Vehicles with Compression Ignition Engines including Hybrids				
	Mono Fuel			Bi- Fuel <sup>(3)</sup>			Flex Fuel	Flex Fuel	Mono Fuel	Dual Fuel	
	Gasoline (E5/E10/E12/E15)	LPG	CNG/ Bio-Methane/ Bio-Gas/ LNG	H <sub>2</sub>	HCNG (Hydrogen + CNG)	Gasoline (E5/E10/E12/E15)	Gasoline (E5/E10/E12/E15)	Gasoline (E5/E10/E12/E15)	Diesel ( B7)	Diesel (B7)	Diesel + CNG
						LPG	CNG / Bio-Methane	Ethanol (E20/E85)/(E100)	Bio-diesel up to 100% <sup>(1)</sup>		
Gaseous Pollutants (Type 1 Test)	Yes	Yes	Yes	Yes	Yes	Yes (Both Fuels)	Yes (Both Fuels)	Yes (Both Fuels)	Yes (Both Fuels)	Yes	Yes
<sup>(2)</sup> Type 1 Test Particulate Mass	Yes	No	No	No	No	No	No	No	Yes (Both Fuels)	Yes	Yes
Idle Emission (Type II)	Yes	Yes	Yes	Yes	Yes	Yes (gasoline only)	Yes (gasoline only)	Yes (gasoline only)	No	No	No
Crankcase Emission (Type III)	Yes	Yes	Yes	Yes	Yes	Yes	Yes	Yes	Yes	Yes	Yes

Evaporative Emission (Type IV)	Yes	No	No	Yes	Yes	Yes (Gasoline only)	Yes (Gasoline only)	Yes (Gasoline only)	No	No	No
Durability (Type V Test)	Yes	Yes	Yes	Yes	Yes	Yes (Gasoline only)	Yes (Gasoline only)	Yes (Gasoline only)	Yes (B7 only)	Yes	Yes
<sup>(4)</sup> CO <sub>2</sub> & Fuel Consumption	Yes	Yes	Yes	No	No	Yes (Both fuels)	Yes (Both fuels)	Yes (Both fuels)	Yes (Both fuels)	Yes	Yes
OBD Stage II	Yes	Yes	Yes			Yes (Gasoline only)	Yes (Gasoline only)	Yes (Gasoline only)	Yes (B7 only)	Yes	Yes
Smoke Opacity	No	No	No	No	No	No	No	No	Yes (B7 only)	No	No

- (1) Vehicles fuelled with bio-diesel blends up to 7% shall be tested with reference diesel (B7) and vehicles fuelled with bio-diesel blends above 7% will be tested with respective blends.
- (2) In case of PI engines, applicable only to vehicles with Direct Injection engines.
- (3) Vehicles models and variants having option for Bi-fuel operation and fitted with limp-home gasoline tank of capacity not exceeding three litres on three wheelers shall be exempted from test in gasoline mode.
- (4) CO<sub>2</sub> emission and fuel consumption shall be measured as per procedure laid down in AIS 137 and as amended time to time.  
When bi-fuel vehicle is combined with a flex fuel vehicle, both test requirements are applicable. Vehicle tested with E100 need not to be tested with E85.

4.0 **Chapter 2, Clause 6.1.1.3.2**

Insert the following text at the end of the paragraph

If a fuel type is not listed in this paragraph, the density of that fuel shall be calculated using the equation given below

The general equation for the calculation of total hydrocarbon density for each reference fuel with a mean composition of  $C_xH_yO_z$  is as follows:

$$\rho_{\text{THC}} = \frac{MW_C + \frac{H}{C} \times MW_H + \frac{O}{C} \times MW_O}{V_M}$$

where:

$\rho_{\text{THC}}$  is the density of total hydrocarbons and non-methane hydrocarbons, g/l;

$MW_C$  is the molar mass of carbon (12.011 g/mol);

$MW_H$  is the molar mass of hydrogen (1.008 g/mol);

$MW_O$  is the molar mass of oxygen (15.999 g/mol);

$V_M$  is the molar volume of an ideal gas at 293.15 K (20° C) and 101.325 kPa (22.413 l/mol);

H/C is the hydrogen to carbon ratio for a specific fuel  $C_xH_yO_z$ ;

O/C is the oxygen to carbon ratio for a specific fuel  $C_xH_yO_z$ .

5.0 **Chapter 2, Clause 6.1.2.1.1**

Substitute the following text with the first paragraph

FC is the fuel consumption of specific fuel, l/100 km (or m<sup>3</sup> per 100 km in the case of natural gas or kg/100 km in the case of hydrogen)

6.0 **Chapter 2, Clause 6.1.2.1.1**

Insert the following text before the existing text

(j) Fuel consumption for any test fuel may be calculated using the following equation :

$$FC = \frac{MW_C + \frac{H}{C} \times MW_H + \frac{O}{C} \times MW_O}{MW_C \times \rho_{fuel} \times 10} \times \left( \frac{MW_C}{MW_C + \frac{H}{C} \times MW_H + \frac{O}{C} \times MW_O} \times HC + \frac{MW_C}{MW_{CO}} \times CO + \frac{MW_C}{MW_{CO_2}} \times CO_2 \right)$$

H/C is the hydrogen to carbon ratio of a specific fuel  $C_xH_yO_z$ ;

O/C is the oxygen to carbon ratio of a specific fuel  $C_xH_yO_z$ ;

$MW_C$  is the molar mass of carbon (12.011 g/mol);

$MW_H$  is the molar mass of hydrogen (1.008 g/mol);

$MW_O$  is the molar mass of oxygen (15.999 g/mol);

PRINTED BY  
 THE AUTOMOTIVE RESEARCH ASSOCIATION OF INDIA  
 P.B. NO. 832, PUNE 411 004  
 ON BEHALF OF  
 AUTOMOTIVE INDUSTRY STANDARDS COMMITTEE  
 UNDER  
 CENTRAL MOTOR VEHICLE RULES – TECHNICAL STANDING COMMITTEE  
 SET-UP BY  
 MINISTRY OF ROAD TRANSPORT & HIGHWAYS  
 (DEPARTMENT OF ROAD TRANSPORT & HIGHWAYS)  
 GOVERNMENT OF INDIA  
 20<sup>th</sup> July 2002

**Amendment No. 1 (04/2022)**

**To**

**AIS-137 (Part 2): Test Method, Testing Equipment and Related Procedures for Type Approval and Conformity of Production (COP) Testing of L5 Category Vehicles for Bharat Stage VI (BS VI) Emission Norms as per CMV Rules 115, 116 and 126**

**1.0 Page IV, introduction,**

**Add below reference**

“United Nations Global Technical Regulation No. 18 - Global Technical Regulation on the measurement procedure for two- or three-wheeled motor vehicles with regard to on-board diagnostics - Amendment 1 (ECE/TRANS/180/Add.18/Amend.1)”

**2.0 Page VI, TABLE of CONTENTS, Chapter-7**

**Substitute following text for existing text:**

CHAPTER 7	Test type VIII requirements: OBD stage II environmental tests
APPENDIX 1	OBD Stage II
APPENDIX 2	Functional aspects of On-Board Diagnostic (OBD) systems
APPENDIX 3	Minimum monitoring requirements for an On-Board Diagnostics (OBD) system Stage II
APPENDIX 4	Test type VIII, On-board diagnostic environmental verification test
APPENDIX 5	Administrative provisions

**3.0 Page 2/244, DEFINITIONS, Clause 3.1.4**

Substitute following text for existing text:

3.1.4 “**Access to OBD**” means the availability of all emission-related OBD data including all fault codes required for the inspection, diagnosis, servicing or repair of emissions-related parts of the vehicle, via the serial interface for the standard diagnostic connection pursuant to clause Clause 3.12. of Appendix 2 of Chapter 7

**4.0 Page 3/244, DEFINITIONS,**

Insert the following definitions after clause 3.3.12:

3.3.13 “**Calibration verification number (CVN)**” means the number that is calculated and reported by the ECU/PCU to validate the calibration / software integrity

3.3.14 "Confirmed fault code (Confirmed DTC)" is a diagnostic trouble code stored when an OBD system has confirmed that a malfunction exists.

**5.0 Page 3/244, DEFINITIONS, Clause 3.4.1 and 3.4.3**

Substitute following text for existing text:

3.4.1 "Driving cycle" consists of engine key-on, a driving mode where a malfunction would be detected if present, and engine key-off."

3.4.3 "Deficiency" means, in respect of vehicle OBD systems, that components or systems that are monitored contain temporary or permanent operating characteristics that impair the otherwise efficient OBD monitoring of those components or systems or do not meet all of the other detailed requirements for OBD.

**6.0 Page 4/244, DEFINITIONS,**

Insert the following definitions after clause 3.4.7:

3.4.8 "Diagnostic trouble code (DTC)" or "fault code" is a numeric or alphanumeric identifier for a fault condition identified by the On Board Diagnostic system.

**7.0 Page 4/244, DEFINITIONS, Clause 3.5.5**

Substitute following text for existing text:

3.5.5 "Engine misfire" means lack of combustion in the cylinder(s) of a positive ignition engine due to absence of spark, poor fuel metering, poor compression or any other cause.

**8.0 Page 5/244, DEFINITIONS,**

Insert the following definitions after clause 3.5.11:

3.5.12 "Engine key-on/off" means providing/interrupting electrical power to the electric circuit, sensors, actuators and electronic controllers. It is also referred to as power on/off or ignition on/off.

**9.0 Page 5/244, DEFINITIONS, Clause 3.6.1**

Substitute following text for existing text:

**3.6.1.** "Fuel trim" refers to feedback adjustments to the base fuel schedule. Short-term fuel trim refers to dynamic or instantaneous adjustments. Long-term fuel trim refers to much more gradual adjustments to the fuel calibration schedule than short-term trim adjustments. These long-term adjustments compensate for vehicle differences and gradual changes that occur over time.

**10.0 Page 6/244, DEFINITIONS,**

Insert the following definitions after clause 3.7.2:

**3.7.3** "Generic scan tool" means an external test equipment used for standardized off-board communication with the OBD system in accordance with the requirements of Chapter 6 & 7.

**11.0 Page 7/244, DEFINITIONS, Clause 3.11.10**

Substitute following text for existing text:

3.11.10 “**Malfunction**” means the failure of a component or system that would result in emissions exceeding the OBD threshold limits (OTL), the circuit failure or the OBD system being unable to fulfil the basic monitoring requirements.

**12.0 Page 8/244, DEFINITIONS, Clause 3.14.9**

Substitute following text for existing text:

3.14.9 “**Permanent emission default mode**” refers to a case where the engine management controller permanently switches to a setting that does not require an input from a failed component or system where such a failed component or system would result in increasing emissions from the vehicle exceeding the OBD threshold limits set out in the notification.

**13.0 Page 9/244, DEFINITIONS,**

Insert the following definitions after clause 3.14.14:

3.14.15 “**Pending fault code**” is a diagnostic trouble code stored upon the initial detection of a malfunction prior to illumination of the malfunction indicator.

**14.0 Page 9/244, DEFINITIONS,**

Insert the following definitions after clause 3.15.3:

3.15.4 “**Readiness**” means a status indicating whether a monitor or a group of monitors for which status reporting is required according to Chapter 6 & 7 have run since the fault memory was last cleared.

**15.0 Page 10/244, DEFINITIONS, Clause 3.16.7**

Substitute following text for existing text:

3.16.7 “**Standardized**” means that all data stream information, including all fault codes used, shall be produced only in accordance with industry standards which, by virtue of the fact that their format and their permitted options are clearly defined, provided for a maximum level of harmonization in the motor vehicle industry, and whose use is explicitly permitted in this standard.

**16.0 Page 10/244, DEFINITIONS, Clause 3.16.15**

Substitute following text for existing text:

3.16.15 “**Software**” of the powertrain / engine or drive train control units means a set of algorithms concerned with the operation of powertrain, engine or drive train data processing systems, containing an ordered sequence of instructions that change the state of the powertrain, engine or drive train control unit;



“**Software calibration identification (CAL ID)**” means a series of alphanumeric characters that identify the emission-related calibration and/or software version.

**17.0 Page 11/244, DEFINITIONS, Clause 3.18.3**

Substitute following text for existing text:

- 3.18.3 “**Unrestricted access to the OBD information**” means:
- (a) Access not dependent on an access code obtainable only from the manufacturer, or a similar device; or
  - (b) Access allowing evaluation of the data produced without the need for any unique decoding information, unless that information itself is standardized.

**18.0 Page 11/244, DEFINITIONS, Clause 3.19.2**

Substitute following text for existing text:

- 3.19.2 “**Vehicle type**” means a category of power-driven vehicles which do not differ in essential engine/vehicle and OBD system characteristics.

**19.0 Page 12/244, DEFINITIONS,**

Insert the following definitions after clause 3.20:

- 3.20.1 A “**key cycle**” consists of engine key-on, engine cranking and idling where a malfunction would be detected if present, followed by engine key-off.

**20.0 Page 62/244, Chapter 2, Appendix 1, Table 1**

Add at the end of the table

**Table 1**

**LIST OF ACRONYMS AND SYMBOLS**

<b>Item</b>	<b>Unit</b>	<b>Term</b>
APS	-	Accelerator (Pedal / Handle) Position Sensor
CAN	-	Controller Area Network
CLV	-	Calculated Load Value
CI	-	Compression Ignition Engine
CO	mg/km	Carbon Monoxide
CO2	g/km	Carbon Dioxide
CVN	-	Calibration Verification Number
DF	-	Deterioration Factors

DTC		Diagnostic Trouble Code
E85	-	Ethanol Blended Petrol, Up To 85% Ethanol
ECU	-	Engine Control Unit
EGR	-	Exhaust Gas Recirculation System
ETC	-	Electronic Throttle Control
HC	mg/km	Hydrocarbons
HCNG	-	Hydrogen-Compressed Natural Gas Mixtures
ID	-	Identifier
ISO	-	International Organization for Standardization
KAM	-	Keep Alive Memory
LPG	-	Liquefied Petroleum Gas
MI	-	Malfunction Indicator
NOx	mg/km	Nitrogen Oxides
OBD	-	On-Board Diagnostics
ODX	-	Open Diagnostic Data Exchange
OTL	-	OBD Threshold Limits
PCU	-	Powertrain Control Unit
PI	-	Positive Ignition Engine
PID	-	Parameter Identifier
PM	mg/km	Particulate Mass
PTO	-	Power Take-Off Unit
SAE	-	Society Of Automotive Engineers, USA Based Globally Active Standardization Organization
Test type I	-	Test Of Tailpipe Emissions After Cold Start

Test type V	-	Test Of Durability Of The Vehicle's Pollution Control Devices, Mix Of Distance Accumulation And Test Type I Verification Testing
Test type VIII	-	Special Test Type I With Induced Fault Mode To Assess The Impact On The Tailpipe Emission Performance Of A Vehicle
TPS	-	Throttle (Accelerator Actuator) Position Sensor
UDS	-	Unified Diagnostic Services
VIN	-	Vehicle Identification Number
WMTC		World-Harmonised Motorcycle Test Cycle
IDC	-	Indian Driving Cycle

**21.0 Page 184/244, Chapter 7**

Substitute following text for existing text:

**Chapter 7 (TEST TYPE VIII REQUIREMENTS: OBD STAGE II (OBD –II)  
ENVIRONMENTAL TESTS**

**1.0 Introduction**

- 1.1. This chapter prescribes the requirements for On-Board Diagnostic stage 2 (OBD II) systems for vehicles to detect, and, if applicable, record and/or communicate failures of specific vehicle and engine systems that affect the environmental performance of these systems, as described in the specific appendices to this chapter..
- 1.2. In addition, this chapter specifies the elements concerning the OBD system to facilitate the diagnosis, efficient and effective repair and maintenance of specific vehicle and engine systems without containing mandatory prescriptions for this purpose.
- 1.3. OBD should not oblige manufacturers to change or add fuelling or ignition hardware and should not impose fitting of an electronic carburetor, electronic fuel injection or electronically controlled ignition coils, providing the vehicle complies with the applicable environmental performance requirements. Compliance with the OBD requirements implies that if fuel delivery, spark delivery or intake air hardware is electronically controlled, the applicable

input or output circuits need to be monitored, limited to the items and failure modes listed in Table 1 of Appendix 3 of this chapter.

In the case of a mechanical carburetor fitted with a throttle position sensor providing a circuit signal as input to the PCU / ECU to determine the engine load, which on its turn would be used to electronically control spark delivery, requires monitoring of that throttle position sensor circuit. Also other sensors or actuator circuits listed in Table 1 of Appendix 3 of this chapter shall be monitored although not directly used to control fuel delivery, spark delivery or intake air control. An example of such a case would be the wheel speed sensor circuits in case the vehicle speed would be calculated in the PCU / ECU from the wheel rotation speeds and which would be used as input to control the environmental performance of the vehicle.

## **2.0 SCOPE AND APPLICATION**

Scope of this Chapter with regard to the propulsion unit and fuel type is defined in sub-rule 20 of the CMV Rule 115.

## **3.0 DEFINITIONS:** (Refer Overall Requirements in Chapter 1)

## **4.0 LIST OF ACRONYMS AND SYMBOLS:** refer appendix 1 to chapter 2

## **5.0 GENERAL REQUIREMENTS**

5.1. Vehicles, systems and components shall be so designed, constructed and assembled by the manufacturer, so as to enable the vehicle, in normal use and maintained according to the prescriptions of the manufacturer, to comply with the provisions of this chapter during its useful life.

### **5.2. BI-FUELLED GAS VEHICLES**

In general, all the OBD requirements applying to a mono-fuelled vehicle apply to bi-fuelled gas vehicles for each of the fuel types (as per CMV Rule 115 ( 20)). To this end, one of the following two alternatives in Clauses 5.2.1. or 5.2.2. of this Chapter or any combination thereof shall be used.

5.2.1. One OBD system for both fuel types

5.2.1.1. The following procedures shall be executed for each diagnostic in a single OBD system for operation on fuel types (as per CMV Rule 115 (20), either independent of the fuel currently in use or fuel type specific:

(a) Activation of Malfunction Indicator (MI) (see Clause 1.1.12. of Appendix 1 of this chapter);

(b) Diagnostic trouble code storage (see Clause 1.1.13. of Appendix 1 of this chapter);

- (c) Extinguishing the MI (see Clause 1.1.14. of Appendix 1 of this chapter);
- (d) Erasing a diagnostic trouble code (see Clause 1.1.15. of Appendix 1 of this chapter).

For components or systems to be monitored, either separate diagnostics for each fuel type can be used or a common diagnostic.

- 5.2.1.2. The OBD system can reside in either one or more computers.
- 5.2.2. Two separate OBD systems, one for each fuel type.
- 5.2.2.1. The following procedures shall be executed independently of each other when the vehicle is operated on fuel types (as per CMV Rule 115 (20)):
  - (a) Activation of Malfunction Indicator (MI) (see Clause 1.1.12. of Appendix 1 of this chapter);
  - (b) Diagnostic trouble code storage (see Clause 1.1.13. of Appendix 1 of this chapter);
  - (c) Extinguishing the MI (see Clause 1.1.14. of Appendix 1 of this chapter);
  - (d) Erasing a diagnostic trouble code (see Clause 1.1.15. of Appendix 1 of this chapter).
- 5.2.2.2. The separate OBD systems can reside in either one or more computers.
- 5.2.3. Specific requirements regarding the transmission of diagnostic signals from bi-fuelled gas vehicles.
  - 5.2.3.1. On a request from a diagnostic scan tool, the diagnostic signals shall be transmitted on one or more source addresses. The use of source addresses is set out in ISO 15031-5:2011.
  - 5.2.3.2. Identification of fuel specific information can be realized as follows:
    - (a) By use of source addresses;
    - (b) By use of a fuel select switch;
    - (c) By use of fuel specific diagnostic trouble codes.
- 5.2.4. Regarding the status code (described in Clause 1.1.13. of Appendix 1 of this chapter), one of the following two alternatives has to be used if one or more of the diagnostics reporting readiness is fuel type specific:
 

The status code is fuel specific, i.e. use of two status codes, one for each fuel type;

The status code shall indicate fully evaluated control systems for fuel types (as per CMV Rule 115 (20) when the control systems are fully evaluated for one of the fuel types.

If none of the diagnostics reporting readiness is fuel-type specific, only one status code has to be supported.

5.3. **Requirements relating to the approval/certification of on-board diagnostic systems**

5.3.1. A manufacturer may ask the test agency to accept an OBD system for approval / certification even if the system contains one or more deficiencies so that the specific requirements of this chapter are not fully met.

5.3.2. In considering the request, the test agency shall determine whether compliance with the requirements of this chapter is unfeasible or unreasonable.

The test agency shall take into consideration data from the manufacturer detailing factors such as, but not limited to, technical feasibility, lead time and production cycles including phase-in or phase-out of engines or vehicle designs and programmed upgrades of computers, the extent to which the resultant OBD system will be effective in complying with the requirements of this Chapter and whether the manufacturer has demonstrated an acceptable level of effort to comply with those requirements.

5.3.2.1. The test agency shall not accept any deficiency request that includes the complete lack of a required diagnostic monitor.

5.3.2.2 The test agency shall not accept any deficiency request that does not respect the OBD threshold limits in the notification, if applicable.

5.3.3. For OBD II system, in the identified order of deficiencies, those relating to clauses 1.1.4.1., 1.1.4.3. and 1.1.4.4. for positive-ignition engines and clauses 1.1.5.1., 1.1.5.3. and 1.1.5.4. for compression-ignition engines, of Appendix 1., shall be identified first.

5.3.4. Prior to, or at the time of, approval/certification, no deficiency shall be accepted in respect of the requirements of Clause 3 of Appendix 2 except Clause 3.11 of Appendix 2.; as applicable.

5.3.5. **DEFICIENCY PERIOD**

5.3.5.1. A deficiency may be carried over for a period of two years after the date of approval/certification of the vehicle type unless it can be adequately demonstrated that substantial vehicle hardware modifications and additional lead-time beyond two years would be necessary to correct it.

In such a case, it may be carried over for a period not exceeding three years.

5.3.5.2. A manufacturer may ask the test agency to accept a deficiency retrospectively when it is discovered after the original approval/certification. In this case, the deficiency may be carried over for a period of two years after the date of notification to the test agency unless it can be adequately demonstrated that substantial vehicle hardware modifications and additional lead-time beyond two years would be necessary to correct it. In such a case, it may be carried over for a period not exceeding three years.

5.3.6 The vehicle family criteria laid down in Chapter 8 with regards to test type VIII shall also be applicable for the functional on-board diagnostic requirements set out in this chapter.

5.4 **OBD threshold limits**

The requirements of OBD threshold limits are set out in the notification.

5.5. **PROPULSION FAMILY DEFINITION WITH REGARD TO OBD AND IN PARTICULAR TO TEST TYPE VIII**

5.5.1. A representative parent vehicle shall be selected to test and demonstrate to the test agencies the functional on-board diagnostic requirements set out in Appendix 2 and to verify the test type VIII requirements laid down in Appendix 4 based on the propulsion family definition laid down in Chapter 8.

All members of the family shall comply with the applicable requirements set out in this chapter.

5.6. **DOCUMENTATION**

The vehicle manufacturer shall complete the information document in accordance with the items listed in Appendix 5 of this chapter or AIS 007, as amended from time to time, and submit it to the test agency.

**22.0 Page 192/244, Chapter 7, Appendix 1**

Substitute the following Appendices 1, 2, 3, 4 and 5 to chapter 7:

**APPNEDIX 1 TO CHAPTER 7**

**FUNCTIONAL ASPECTS OF OBD SYSTEM-OBD STAGE II**

**1.0. OBD II system**

The technical requirements of this appendix shall be mandatory for vehicles in the scope of AIS-137 (Part-2) equipped with OBD II systems.

**1.1. Functional OBD Requirements**

- 1.1.1. OBD Monitoring
- a) The OBD system shall monitor and report any electric circuit and electronics failure of the emission control system, which is triggered when the OBD threshold limits as notified are being exceeded. Also, the OBD system shall monitor and report emission control system failures and degradations which result in the OBD threshold limits, as notified being exceeded.
  - b) If fitted, manufacturer shall monitor and report any electric circuit and electronics failure of the emission control system, which may result in any operating mode leading to the significantly reduced engine propulsion torque.

Note: All functional safety related / torque reduction clauses in this Chapter are applicable only if vehicle is fitted with significant torque reduction strategies

- 1.1.2. Vehicles in the scope of this appendix shall be equipped with an OBD system so designed, constructed and installed in a vehicle as to continue monitoring to identify types of deterioration or malfunction over the entire life of the vehicle. In achieving this objective, vehicles which have travelled distances in excess of the Type V durability mileage / distance as notified may show some deterioration in OBD system performance such that the OBD emission thresholds, given in the notification, may be exceeded before the OBD system signals a failure to the driver of the vehicle.

- 1.1.2.1. Access to the OBD system required for the inspection, diagnosis, servicing or repair of the vehicle shall be unrestricted and standardized. All OBD relevant diagnostic trouble codes shall be consistent with Clause 3.11. of Appendix 2. of this Chapter.

- 1.1.2.2. At the manufacturer's discretion, to aid technicians in the efficient repair of vehicles, the OBD system may be extended to monitor and report on any other on-board system. Extended diagnostic systems shall not be considered as falling under the scope of approval/certification requirements.

1.1.3. **Monitoring requirements of electric circuit and electronics failure**

For the purposes of clauses 1.1.1., 1.1.7. and 1.1.8., the electric circuit and electronic failure diagnostics with regard to OBD shall at a minimum contain the sensor and actuator diagnostics as well as the internal diagnostics of the electronic control units required in Table 1 of Appendix 3. of this chapter.

1.1.4. **Monitoring requirements for vehicles equipped with positive-ignition engines**

The OBD system shall indicate the failure of an emission-related component or system when that failure results in emissions exceeding the OBD threshold limits referred to in the notification. In satisfying the requirements of clause 1.1.1. the OBD system shall, at a minimum, monitor for:



#### 1.1.4.1. Catalytic converter deterioration and performance

The reduction in the efficiency of the catalytic converter with respect to emissions of NO<sub>x</sub> shall be monitored. Manufacturers may monitor the front catalyst alone or in combination with the next catalyst(s) downstream. Each monitored catalyst or catalyst combination shall be considered to be malfunctioning if the emissions exceed the NO<sub>x</sub> thresholds identified in the notification.

#### 1.1.4.2. Engine Misfire

The presence of engine misfire in the engine operating region bounded by the following lines:

- (a) Low speed limit: A minimum speed of 2500 min<sup>-1</sup> or normal idle speed +1000 min<sup>-1</sup>, whichever is the lower
- (b) High speed limit: A maximum speed of 8000 min<sup>-1</sup> or 1000 min<sup>-1</sup> greater than the highest speed occurring during a type I test cycle or maximum design engine speed minus 500 min<sup>-1</sup>, whichever is lower
- (c) A line joining the following engine operating points:
  - (i) A point on the low speed limit defined in (a) with the absolute value of engine intake pressure at 3.3 kPa higher than the absolute value of pressure at the positive torque line;
  - (ii) A point on the high-speed limit defined in (b) with the absolute value of engine intake pressure at 13.3 kPa higher than the absolute value of pressure at the positive torque line.

The engine operation region for misfire detection is reflected in below Figure.

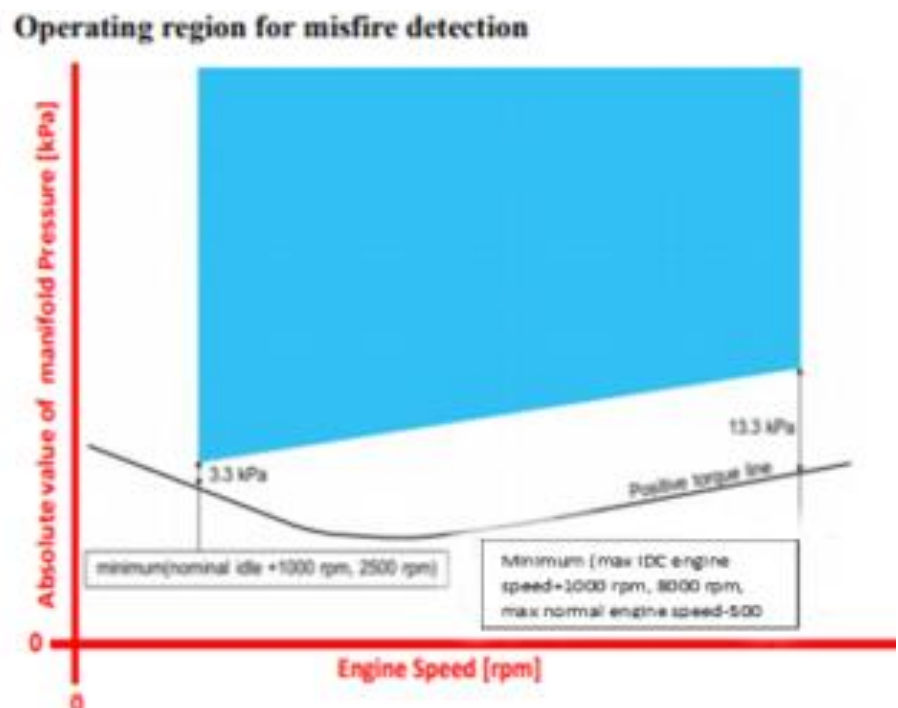

- 1.1.4.3. Oxygen sensor deterioration  
This clause shall mean that the deterioration of all oxygen sensors fitted and used for monitoring malfunctions of the catalytic converter in accordance with the requirements of this appendix shall be monitored.
- 1.1.4.4. The electronic evaporative emission purge control shall, at a minimum, be monitored for circuit continuity.
- 1.1.4.5. Reserved
- 1.1.5. **Monitoring requirements for vehicles equipped with compression ignition engines**  
The OBD system shall indicate the failure of an emission-related component or system when that failure results in emissions exceeding the OBD threshold limits referred to in the notification.  
In satisfying the requirements of clause 1.1.1., the OBD system shall, at a minimum, monitor for:
- 1.1.5.1. Catalytic converter deterioration and performance.  
Reduction in the efficiency of the catalytic converter, where fitted;
- 1.1.5.2. The functionality and integrity of the particulate trap, where fitted.
- 1.1.5.3. The fuel-injection system electronic fuel quantity and timing actuator(s) is/are monitored for circuit continuity and total functional failure.
- 1.1.5.4. Malfunctions and the reduction in efficiency of the EGR system, shall be monitored.
- 1.1.5.5. Malfunctions and the reduction in efficiency of a NOx after-treatment system using a reagent and the reagent dosing subsystem shall be monitored.
- 1.1.5.6. Malfunctions and the reduction in efficiency of NOx after-treatment not using a reagent shall be monitored.
- 1.1.6. If active, the emission control system components or systems, or emission related powertrain components or systems, which are connected to a computer shall be monitored, the failure of which may result in tailpipe emissions exceeding the OBD threshold limits given in the notification.
- 1.1.7. (a) Unless otherwise monitored, any other electronic powertrain component connected to a computer relevant for environmental performance, including any relevant sensors to enable monitoring functions to be carried out, shall be monitored for electric/electronic circuit failures. In particular, these electronic components shall be continuously monitored for any electric circuit continuity failure, shorted electric circuits. electric range/performance and stuck signal of the emissions control system.  
(b) In addition, any other electronic powertrain component connected to a computer relevant for functional safety, including any relevant

sensors to enable monitoring functions to be carried out, shall be monitored for electric/electronic circuit failures.

- 1.1.8. (a) Unless otherwise monitored, for any other powertrain component connected to a computer relevant for the environmental performance, without prejudice to the Table 1 of Appendix 3 , the relevant diagnostic trouble code shall be stored.
- (b) In addition, for any other powertrain component connected to a computer relevant for the functional safety and/or triggering of any programmed ‘limp-home’ operating mode which significantly reduces engine torque, e.g. to safeguard powertrain components, without prejudice to the Table 1 of Appendix 3 , the relevant diagnostic trouble code shall be stored.
- 1.1.9. Manufacturers may demonstrate to the test agencies that certain components or systems need not be monitored if, in the event of their total failure or removal, emissions do not exceed the OBD threshold limits given in the notification.
- 1.1.10. A sequence of diagnostic checks shall be initiated at each engine start and completed at least once provided that the correct test conditions are met. The test conditions shall be selected in such a way that they all occur in the course of normal driving as represented by the type I test of Chapter 2. If the failure cannot be reliably detected under the type I test of Chapter 2 test conditions, the manufacturer may propose supplemental test conditions that do allow robust detection of the failure to be agreed with the test agency.
- 1.1.11. The OBD system shall be so designed, constructed and installed in a vehicle as to enable it to comply with the requirements of this appendix during conditions of normal use.
- 1.1.11.1. Temporary disablement of the OBD system
- 1.1.11.1.1 A manufacturer may disable the OBD system if its ability to monitor is affected by low fuel levels or below the minimum state of charge of the electric system batteries (maximum discharge of capacity). Disablement shall not occur when the fuel tank level is above 20 per cent of the nominal capacity of the fuel tank.
- 1.1.11.1.2. A manufacturer may disable the OBD system at ambient engine starting temperatures below 266.2K (-7°C) or at elevations over 2440 metres above sea level or an ambient pressure of less than 75.7kPa, provided it submits data and/or an engineering evaluation which adequately demonstrate that monitoring would be unreliable in such conditions. It may also request disablement of the OBD system at other conditions if it demonstrates to the test agencies with data and/or an engineering evaluation that misdiagnosis would occur under such conditions. It is not necessary to illuminate the malfunction indicator (MI) if the OBD threshold limits are exceeded during regeneration, provided no defect is present.
- 1.1.11.1.3. For vehicles designed to accommodate the installation of power take-off units, disablement of affected monitoring systems is permitted

provided disablement occurs only when the power take-off unit is active.

1.1.11.1.4. The manufacturer may temporarily disable the OBD system in the following conditions:

- (a) For flex-fuel or mono/bi-fuel gas vehicles for one minute after refuelling to allow for the recognition of fuel quality and composition by the Powertrain Control Unit(s) (PCU);
- (b) For bi-fuel vehicles for five seconds after fuel switching to allow for engine parameters to be readjusted;
- (c) The manufacturer may deviate from these time limits if it can be demonstrated that stabilisation of the fuelling system after refuelling or fuel switching takes longer for justified technical reasons. In any case, the OBD system shall be re-enabled as soon as either the fuel quality or composition is recognised or the engine parameters are readjusted.

1.1.11.2. Engine misfire in vehicles equipped with positive-ignition engines.

1.1.11.2.1. Manufacturers may adopt higher misfire percentage malfunction criteria than those declared to the test agency, under specific engine speed and load conditions where it can be demonstrated to the test agency that the detection of lower levels of misfire would be unreliable. In terms of OBD monitoring, it is that percentage of misfires out of a total number of firing events (as declared by the manufacturer) that would result in emissions exceeding the OBD thresholds set out in the notification, or that percentage that could lead to an exhaust catalyst(s) overheating, causing irreversible damage.;

1.1.11.2.2. When a manufacturer can demonstrate to the test agency that the detection of higher levels of misfire percentages is still not feasible, or that misfire cannot be distinguished from other effects (e.g. rough roads, transmission shifts, after engine starting, etc.), the misfire monitoring system may be disabled when such conditions exist.

1.1.11.3. Identification of deterioration or malfunctions may also be done outside a driving cycle (e.g. after engine shutdown).

1.1.12. **Activation of the Malfunction Indicator (MI)**

1.1.12.1. The OBD system shall incorporate a malfunction indicator readily perceivable to the vehicle operator. The MI shall not be used for any purposes other than to indicate emergency start-up or limp-home routines to the driver. The MI shall be visible in all reasonable lighting conditions. When activated, it shall display a symbol in conformity with ISO 2575:2010, symbol F.01. A vehicle shall not be equipped with more than one general purpose MI for emission-related problems or powertrain faults leading to significantly reduced torque. Separate specific purpose tell-tales (e. g. brake system, fasten seat belt, oil pressure, etc.) are permitted. The use of red colour for an MI is prohibited.

- 1.1.12.2. For strategies requiring more than two preconditioning cycles for MI activation, the manufacturer shall provide data and/or an engineering evaluation which adequately demonstrate that the monitoring system is equally effective and timely in detecting component deterioration. Strategies requiring on average more than ten driving cycles for MI activation are not accepted.
- (a) The MI shall also activate whenever the powertrain control enters a permanent emission default mode of operation if the OBD threshold limits in the notification are exceeded or if the OBD system is unable to fulfil the basic monitoring requirements laid down in clauses 1.1.4. or 1.1.5. of this Appendix.
- (b) In addition, the MI shall activate whenever the powertrain control enters a limp home mode.
- 1.1.12.3. The MI shall operate in a distinct warning mode, e.g. a flashing light, during any period in which engine misfire occurs at a level likely to cause catalyst damage, as specified by the manufacturer.
- 1.1.12.4. The MI shall also activate when the vehicle's ignition is in the "key on" position before engine starting or cranking and deactivate if no malfunction has been detected. For vehicles not equipped with a battery, the MI shall illuminate immediately after engine starting and shall subsequently be deactivated after 5 seconds, if no malfunction has previously been detected.
- 1.1.13. The OBD system shall record fault code(s) indicating the status of the emission control system or of the functional safety system leading to an operation mode with significantly reduced torque in comparison to normal operation mode. Separate status codes shall be used to identify correctly functioning emission control systems and those emission control systems which need further vehicle operation to be fully evaluated. If the MI is activated due to deterioration or malfunction or permanent emission default modes of operation, a fault code shall be stored that identifies the type of malfunction. A fault code shall also be stored in the cases referred to in Clauses 1.1.7. and 1.1.8.
- 1.1.13.1. The distance travelled by the vehicle while the MI is activated shall be available at any moment through the serial port on the standardised diagnostic connector. By means of derogation for vehicles equipped with a mechanically operating odometer that does not allow input to the electronic control unit, including such vehicles equipped with a CVT that does not allow for an accurate input to electronic control unit, "distance travelled" may be replaced with "engine operation time" and shall be made available at any moment through the serial port on the standardised diagnostic connector. Engine operation time in this context means the total accumulated time in which the propulsion unit(s) provide(s) mechanical output (e.g. the crankshaft of a combustion engine) and/or the engine is shut-down by the control system triggering the MI activation.

- 1.1.13.2. In the case of vehicles equipped with positive-ignition engines, misfiring cylinders need not be uniquely identified if a distinct single or multiple cylinder misfire fault code is stored.
- 1.1.13.3. The MI may be activated at levels of emissions below the OBD threshold limits set out in the notification.
- 1.1.13.4. The MI may be activated if a default mode is active without significant reduction of propulsion torque.
- 1.1.14. Extinguishing the MI
  - 1.1.14.1. If misfire at levels likely to cause catalyst damage (as specified by the manufacturer) is no longer taking place, or if the engine is operated after changes to speed and load conditions where the level of misfire will not cause catalyst damage, the MI may be switched back to the previous state of activation during the first driving cycle on which the misfire level was detected and to the normal activated mode on subsequent driving cycles. If the MI is switched back to the previous state of activation, the corresponding fault codes and stored freeze-frame conditions may be erased.
  - 1.1.14.2. For all other malfunctions, the MI may be deactivated after three subsequent sequential driving cycles during which the monitoring system responsible for activating the MI ceases to detect the malfunction and if no other malfunction has been identified that would independently activate the MI.
- 1.1.15. Erasing a diagnostic trouble code
  - 1.1.15.1. The OBD system may erase a diagnostic trouble code and the distance travelled and freeze-frame information if the same fault is not re-registered in at least 40 engine warm-up cycles.
  - 1.1.15.2. Stored faults shall not be erased by disconnection of the on-board computer from the vehicle power supply or by disconnection or failure of the vehicle battery or batteries.
- 1.1.16. Additional provisions for vehicles employing engine shut-off strategies
  - 1.1.16.1. Driving cycle
    - 1.1.16.1.1. Autonomous engine restarts commanded by the engine control system following an engine stall may be considered a new driving cycle or a continuation of the existing driving cycle.

## **APPENDIX 2 TO CHAPTER 7**

### **FUNCTIONAL ASPECTS OF ON-BOARD DIAGNOSTIC (OBD) SYSTEMS**

#### **1.0 Introduction**

The on-board diagnostic systems fitted on vehicles in the scope of appendix 1 shall comply with the detailed information and functional requirements and verification test procedures of this appendix and verify if the systems are capable of meeting the functional part of the on-board diagnostic requirements.

- 2.0 On-board diagnostic functional verification testing
- 2.1. The on-board diagnostic environmental system performance and the functional OBD capabilities may be verified and demonstrated to the test agency by performing the type VIII test procedure referred to in Appendix 4 of this Chapter.
- 3.0 Diagnostic signals
- 3.1. Upon determination of the first malfunction of any component or system, "freeze-frame" engine conditions present at the time shall be stored in computer memory in accordance with the specifications in Clause 3.10. of this appendix. Stored engine conditions shall include, but are not limited to, calculated load value, engine speed, fuel trim value(s) (if available), fuel pressure (if available), vehicle speed (if available), coolant temperature (if available), intake manifold pressure (if available), closed- or open-loop operation (if available) and the diagnostic trouble code which caused the data to be stored.
- 3.1.1. The manufacturer shall choose the most appropriate set of conditions facilitating effective and efficient repairs in freeze-frame storage. Only one frame of data is required. Manufacturers may choose to store additional frames provided that at least the required frame can be read by a generic scan tool meeting the specifications of Clause 3.9 of this Appendix. If the diagnostic trouble code causing the conditions to be stored is erased in accordance with Clause 1.1.15. of Appendix 1 of Chapter 7 , the stored engine conditions may also be erased.
- 3.1.2. Should a subsequent fuel system or misfire malfunction occur, any previously stored freeze-frame conditions shall be replaced by the fuel system or misfire conditions (whichever occurs first).
- 3.1.3. Calculated load value shall be calculated as to indicate percent of peak available torque during normal, fault-free conditions. In case of PI engines, calculated load value may be calculated as follows:  
Equation 1:
- $$CLV = \frac{\text{Current\_airflow}}{\text{Peak\_airflow(at\_sea\_level)}} \cdot \frac{\text{Atmospheric\_pressure\_ (at\_sea\_level)}}{\text{Barometric\_pressure}}$$
- 3.1.4. Alternatively, the manufacturer may choose another appropriate load variable of the propulsion unit (such as throttle position, intake manifold pressure, etc.) and shall demonstrate that the alternative load variable correlates well with calculated load variable set out in Clause 3.1.3. of this appendix and is in accordance with the specifications in Clause 3.10. of this appendix.
- 3.2. If available, the following signals in addition to the required freeze-frame information, shall be made available on demand through the serial port on the standardised diagnostic connector, if the information is available to the on-board computer or can be determined using information available to the on-board computer: diagnostic trouble codes, engine coolant temperature, fuel control system status (closed-

loop, open-loop, other), fuel trim, ignition timing advance, intake air temperature, manifold air pressure, air flow rate, engine speed, throttle position sensor output value, secondary air status (upstream, downstream or atmosphere), calculated load value, vehicle speed and fuel pressure.

- (a) The signals shall be provided in standard units based on the specifications in Clause 3.10. of this Appendix. Actual signals shall be clearly identified separately from default value

A manufacturer may require in addition that actual signals shall be clearly identified separately from limp-home signals.

- 3.3. For all control systems for which specific on-board evaluation tests are conducted (catalyst, oxygen sensor etc.) except, if applicable, misfire detection, fuel system monitoring and comprehensive component monitoring, the results of the most recent test performed by the vehicle and the limits to which the system is compared, shall be made available through the serial data port on the standardised diagnostic connector according to the specifications in Clause 3.12. of this Appendix. For the monitored components and systems excepted above, a pass/fail indication for the most recent test results shall be available through the standardised diagnostic connector.
- 3.4. The OBD requirements to which the vehicle is certified and the major control systems monitored by the OBD system in accordance with the specifications in Clause 3.10. of this appendix, shall be made available through the serial data port on the standardised diagnostic data link connector according to the specifications in Clause 3.8 of this Appendix.
- 3.5. The software identification number (Cal ID) and calibration verification numbers (CVN) shall be made available through the serial port on the standardized diagnostic data link connector. Both numbers shall be provided in a standardized format in accordance with the specifications in clause 3.10. of this Appendix.
- 3.6. The diagnostic system is not required to evaluate components during malfunction if such evaluation would result in a risk to safety or component failure.
- 3.7. The diagnostic system shall provide for standardised and unrestricted access to OBD and conform to the following ISO standards or SAE specification. Later versions may be used at the manufacturers' discretion.
- 3.8. One of the following standards with the restrictions described shall be used as the on-board to off-board communications link:
  - (a) ISO 9141-2:1994/Amd 1:1996: "Road Vehicles — Diagnostic Systems — Part 2: CARB requirements for interchange of digital information";
  - (b) SAE J1850: March 1998 "Class B Data Communication Network Interface. Emission related messages shall use the cyclic



redundancy check and the three-byte header and not use inter byte separation or checksums";

- (c) ISO 14229-3:2012: "Road vehicles — Unified Diagnostic Services (UDS) — Part 3: Unified diagnostic services on CAN implementation";
- (d) ISO 14229-4:2012: "Road vehicles — Unified Diagnostic Services (UDS) — Part 4: Unified diagnostic services on FlexRay implementation";
- (e) ISO 14230-4:2000: "Road Vehicles — Keyword protocol 2000 for diagnostic systems — Part 4: Requirements for emission-related systems";
- (f) ISO 15765-4:2011: "Road vehicles — Diagnostics on Controller Area Network (CAN) — Part 4: Requirements for emissions-related systems", dated 1 November 2001;
- (g) ISO 22901-2:2011: "Road vehicles — Open diagnostic data exchange (ODX) — Part 2: Emissions-related diagnostic data".

- 3.9. Test equipment and generic scan tool needed to communicate with OBD systems shall meet or exceed the functional specification in ISO 15031-4:2005: "Road vehicles — Communication between vehicle and external test equipment for emissions-related diagnostics — Part 4: External test equipment".
- 3.10. Basic diagnostic data (as specified in Clause 3 of this Appendix) and bi-directional control information shall be provided using the format and units described in ISO 15031-5:2011 "Road vehicles — Communication between vehicles and external test equipment for emissions-related diagnostics — Part 5: Emissions-related diagnostic services", dated 1 April 2011 or SAE J1979 dated 23 February 2012, and shall be available using a generic scan tool meeting the requirements of ISO 15031-4:2005.
  - 3.10.1. The vehicle manufacturer shall provide the test agency with details of any diagnostic data, e.g. PIDs, OBD monitor IDs, Test IDs not specified in ISO 15031-5:2011 but relating to this chapter
- 3.11. When a fault is registered, the manufacturer shall identify the fault using an appropriate diagnostic trouble code consistent with those in ISO 15031-6:2010 "Road vehicles — Communication between vehicle and external test equipment for emissions-related diagnostics -Part 6: Diagnostic trouble code definitions" dated 13 August 2010 or SAE J2012 dated 07 March 2013; relating to "emission-related system diagnostic trouble codes". If this is not possible, the manufacturer may use the diagnostic trouble codes of ISO DIS 15031-6:2010. Alternatively, fault codes may be compiled and reported in accordance with ISO 14229:2006. The fault codes shall be fully accessible by standardised diagnostic equipment complying with Clause 3.9. of this appendix.

- 3.12. The connection interface between the vehicle and the diagnostic tester shall be standardised and meet all the requirements of ISO 19689:2016 "Motorcycles and Mopeds — Communication between vehicle and external equipment for diagnostics — Diagnostic connector and related electrical circuits, specification and use" or ISO 15031-3:2004 "Road vehicles — Communication between vehicle and external test equipment for emissions-related diagnostics — Part 3: Diagnostic connector and related electric circuits: specification and use". The preferred installation position is under the seating position. Any other position of the diagnostic connector shall be subject to the test agency's agreement and be readily accessible by service personnel but protected from tampering by non-qualified personnel. The position of the connection interface shall be clearly indicated in the user manual.
- 3.13. The vehicle manufacturer may use an alternative connection interface upon request. Where an alternative connection interface is used, the vehicle manufacturer shall provide an adapter enabling connection to a generic scan tool. Such an adapter shall be provided in a non-discriminating manner to all independent operators.
- 4.0 Reserved
- 5.0 Access to OBD information
- 5.1. Applications for approval/certification or its amendments shall be accompanied by the repair information concerning the vehicle OBD system. This information shall enable manufacturers of replacement or retrofit components to make the parts they manufacture compatible with the vehicle OBD system, with a view to fault-free operation assuring the vehicle user against malfunctions. Similarly, such repair information shall enable the manufacturers of diagnostic tools and test equipment to make tools and equipment that provide for the effective and accurate diagnosis of vehicle control systems.
- 5.2. Upon request, the test agency shall make the repair information on the OBD system available to any interested components, diagnostic tools or test equipment manufacturer on a non-discriminatory basis:
- 5.2.1. A description of the type and number of preconditioning cycles used for the original approval/certification of the vehicle;
- 5.2.2. A description of the type of the OBD demonstration cycle used for the original approval/certification of the vehicle for the component monitored by the OBD system;
- 5.2.3. A comprehensive document describing all sensed components with the strategy for fault detection and MI activation (fixed number of driving cycles or statistical method), including a list of relevant secondary sensed parameters for each component monitored by the OBD system and a list of all OBD output codes and format used (with an explanation of each) associated with individual emission related powertrain components and individual non-emission related components, where monitoring of the component is used to determine MI activation.

5.2.4.

This information may be provided in the form of a table, as follows:

		<p style="text-align: center;">Table 1: Template OBD information list</p> <table border="1" style="margin-left: auto; margin-right: auto;"> <thead> <tr> <th style="writing-mode: vertical-rl; transform: rotate(180deg);">Component</th> <th style="writing-mode: vertical-rl; transform: rotate(180deg);">Diagnostic trouble code</th> <th style="writing-mode: vertical-rl; transform: rotate(180deg);">Monitoring strategy</th> <th style="writing-mode: vertical-rl; transform: rotate(180deg);">Fault detection criteria</th> <th style="writing-mode: vertical-rl; transform: rotate(180deg);">MI activation criteria</th> <th style="writing-mode: vertical-rl; transform: rotate(180deg);">Secondary parameters</th> <th style="writing-mode: vertical-rl; transform: rotate(180deg);">Preconditioning</th> <th style="writing-mode: vertical-rl; transform: rotate(180deg);">Demonstration test</th> <th style="writing-mode: vertical-rl; transform: rotate(180deg);">Default mode</th> </tr> </thead> <tbody> <tr> <td>Catalyst</td> <td>P0420</td> <td>Oxygen sensor 1 and 2 signals</td> <td>Difference between sensor 1 and sensor 2 signals</td> <td>3rd cycle</td> <td>Engine speed, engine load, A/F mode, catalyst temperature</td> <td>Two type I cycles</td> <td>Type I</td> <td>None</td> </tr> </tbody> </table>							Component	Diagnostic trouble code	Monitoring strategy	Fault detection criteria	MI activation criteria	Secondary parameters	Preconditioning	Demonstration test	Default mode	Catalyst	P0420	Oxygen sensor 1 and 2 signals	Difference between sensor 1 and sensor 2 signals	3rd cycle	Engine speed, engine load, A/F mode, catalyst temperature	Two type I cycles	Type I	None
Component	Diagnostic trouble code	Monitoring strategy	Fault detection criteria	MI activation criteria	Secondary parameters	Preconditioning	Demonstration test	Default mode																		
Catalyst	P0420	Oxygen sensor 1 and 2 signals	Difference between sensor 1 and sensor 2 signals	3rd cycle	Engine speed, engine load, A/F mode, catalyst temperature	Two type I cycles	Type I	None																		
5.2.5.	<p>If the test agency receives a request from any interested components, diagnostic tools or test equipment manufacturer for information on the OBD system of a vehicle that has been certified by that test agency to a previous version of this Regulation (if any),</p> <p>(a) That test agency shall, within 30 days, ask the manufacturer of the vehicle in question to make available the information required in Clauses 5.1. and 5.2 of this Appendix;</p> <p>(b) The vehicle manufacturer shall submit this information to that test agency within two months of the request;</p> <p>(c) That test agency shall transmit this information and shall attach this information to the vehicle approval/certification information.</p>																									
5.2.6.	<p>Information can be requested only for replacement or service components that are subject to approval/certification or for components that form part of a system subject to approval/certification.</p>																									
5.2.7.	<p>The request for repair information shall identify the exact specification of the vehicle model for which the information is required. It shall confirm that the information is required for the development of replacement or retrofit parts or components or diagnostic tools or test equipment.</p>																									
5.2.8.	<p>Access to vehicle security features used by authorised dealers and repair shops shall be made available to independent operators under protection of security technology according to the following requirements:</p>																									

		<ul style="list-style-type: none"> <li>(a) Data shall be exchanged ensuring confidentiality, integrity and protection against replay;</li> <li>(b) The standard https//ssl-tls (RFC4346) shall be used;</li> <li>(c) Security certificates in accordance with ISO 20828 shall be used for mutual authentication of independent operators and manufacturers;</li> <li>(d) The independent operator’s private key shall be protected by secure hardware.</li> </ul>
	5.2.8.1.	Reserved
	5.2.8.2.	The independent operator shall be approved and authorized for this purpose on the basis of documents demonstrating that they pursue a legitimate business activity and have not been convicted of relevant criminal activity.
<b>APPENDIX 3 TO CHAPTER 7</b>		
<b>MINIMUM MONITORING REQUIREMENTS FOR ELECTRIC CIRCUIT DIAGNOSTICS OF AN ON-BOARD DIAGNOSTIC (OBD) SYSTEM STAGE II</b>		
	<b>1.0</b>	<b>INTRODUCTION</b> The following minimum monitoring requirements shall apply for OBD systems regarding electric circuit diagnostics.
	<b>2.0</b>	<b>Scope and monitoring requirements</b>
		<ul style="list-style-type: none"> <li>(a) If fitted, the following listed sensors and actuators shall be monitored for electric circuit malfunctions which may cause emissions to exceed the designated OBD threshold limits As notified.</li> <li>(b) If fitted, a manufacturer may require in addition that the following listed sensors and actuators shall be monitored for electric circuit malfunctions which may lead to activation of a default mode that results in a significant reduction of propulsion torque.</li> </ul>
	2.1.	At a minimum the monitored devices with mandatory circuit diagnostics shall be the following

**Table 1**  
**Overview of devices (if fitted) to be monitored in OBD stage II**

No.	Device circuits	Level, refer to 2.3.	Circuit continuity			Circuit rationality <sup>6</sup>			Basic monitoring requirement	Comment No.
			Circuit High	Circuit Low	Open Circuit	Out of Range	Performance Plausibility	Signal stuck		
1	Control module (EUC/PUC) intimate error	3							Yes	(1)
<b>Senor (input to control units)</b>										
1	Accelerator (pedal/handle) position sensor	1	Yes	Yes	Yes	Yes	Yes	Yes		(2)
2	Barometric pressure sensor	1	Yes	Yes	Yes		Yes			
3	Camshaft position sensor	3							Yes	
4	Crankshaft position sensor	3							Yes	
5	Engine coolant temperature sensor	1	Yes	Yes	Yes	Yes	Yes	Yes		(3)
6	Exhaust control valve angle sensor	1	Yes	Yes	Yes	Yes	Yes	Yes		(3)
7	Exhaust gas recirculation sensor	1	Yes	Yes	Yes	Yes	Yes	Yes		(3)
8	Fuel rail pressure sensor	1	Yes	Yes	Yes	Yes	Yes	Yes		(3)
9	Fuel rail temperature sensor	1	Yes	Yes	Yes	Yes	Yes	Yes		(3)
10	Gear shift position sensor (potentiometer type)	1	Yes	Yes	Yes	Yes	Yes	Yes		(3) (4)
11	Gear shift position sensor (switch type)	3					Yes		Yes	(4)
12	Intake air temperature sensor	1	Yes	Yes	Yes	Yes	Yes	Yes		(3)

13	Knock sensor (Non-resonance type)	3							Yes	
14	Knock sensor (Resonance type)	3					Yes			
15	Manifold absolute pressure sensor	1	Yes	Yes	Yes	Yes	Yes	Yes		(3)
16	Mass air flow sensor	1	Yes	Yes	Yes	Yes	Yes	Yes		(3)
17	Engine oil temperature sensor	1	Yes	Yes	Yes	Yes	Yes	Yes		(3)
18	O <sub>2</sub> exhaust sensor (binary / linear) signals	1	Yes	Yes	Yes	Yes	Yes	Yes		(3)
19	Fuel (high) pressure sensor	1	Yes	Yes	Yes	Yes	Yes	Yes		(3)
20	Fuel storage temperature sensor	1	Yes	Yes	Yes	Yes	Yes	Yes		(3)
21	Throttle position sensor	1	Yes	Yes	Yes	Yes	Yes	Yes		(2)
22	Vehicle speed sensor	3					Yes		Yes	(4)
23	Wheel speed sensor	3					Yes		Yes	(4)
<b>Actuators (output control units)</b>										
1	Evaporative emission system purge control valve	2	Yes	Yes	Yes				Yes	(5)
2	Exhaust control valve actuator (motor driven)	3					Yes		Yes	
3	Exhaust gas recirculation control	3					Yes			
4	Fuel injector	2		Yes					Yes	(5)
5	Idle air control system	1	Yes	Yes	Yes		Yes		Yes	(5)
6	Ignition coil primary control circuits	2		Yes					Yes	(5)
7	O <sub>2</sub> exhaust sensor heater	1	Yes	Yes	Yes		Yes		Yes	(5)
8	Secondary air injection system	2	Yes	Yes	Yes				Yes	(5)
9	Throttle by wire actuator	3		Yes					Yes	(5)

		<p>Comments:</p> <p>(1) In case ECU/PCU is operating at reduced functionality and when it generates internal fault/error due to malfunction of hardware or software, then:</p> <p>(a) Monitoring applicable in case of a throttle by wire system being fitted.</p> <p>(b) In addition, a manufacturer may require monitoring in case of an activated default mode leading to a significantly reduced propulsion torque.</p> <p>(2) If redundant APS or redundant TPS are fitted, signal cross check(s) shall meet all circuit rationality requirements. If there is only one APS or TPS fitted, APS or TPS circuit rationality monitoring is not mandatory.</p> <p>(3) Two out of three of the circuit rationality malfunctions shall be monitored in addition to circuit continuity monitoring.</p> <p>(4) Only if used as input to ECU/PCU with relevance to environmental or functional safety performance.</p> <p>(5) Derogation allowed if manufacturer requests, level 3 instead, actuator signal present only without indication of symptom.</p> <p>(6) Provisions related to Circuit rationality will be implemented after being mandated by notification under CMVR.</p>
	2.2.	If there are more of the same device types fitted on the vehicle listed in Table 1 of this Appendix, those devices shall be separately monitored and reported in case of malfunctions.
	2.3.	Sensors and actuators shall be associated with a specific diagnostic level that defines which type of diagnostic monitoring shall be performed as follows:
	2.3.1.	Level 1: sensor/actuator of which at least two circuit continuity symptoms can be detected and reported (i.e. short circuit to ground, short circuit to power and open circuit).
	2.3.2.	Level 2: sensor/actuator of which at least one circuit continuity symptom can be detected and reported (i.e. short circuit to ground, short circuit to power and open circuit).
	2.3.3.	Level 3: sensor/actuator of which at least one symptom can be detected, but not reported separately.
	2.4.	<p>Two out of three symptoms in circuit continuity as well as in circuit rationality monitoring diagnostic may be combined, e.g.</p> <p>(a) Circuit high or open and low circuit;</p> <p>(b) High and low or open circuit;</p> <p>(c) Signal out of range or circuit performance and signal stuck;</p> <p>Circuit high and out of range high or circuit low and out of range low.</p>

2.5.	Exemptions regarding detection Exemption from detecting certain electric circuit monitoring symptoms may be granted in the following cases if the manufacturer can demonstrate to the satisfaction of the test agency that:
2.5.1.	A listed malfunction will not cause emissions to exceed the designated OBD -threshold limits set out in the notification; or
2.5.2.	A listed malfunction will not cause a significant torque loss; or
2.5.3.	the only feasible monitoring strategy would negatively affect vehicle safety or driveability in a significant way.
2.6.	Exemption regarding OBD emission verification tests (test type VIII) At the request of the manufacturer and based on a technical justification to the satisfaction of the test agency, certain OBD monitors listed in Table 1 of this Appendix may be exempted from test type VIII emission verification tests referred to in Appendix 4 of this chapter under the condition that the manufacturer can demonstrate to the test agency that:
2.6.1	The malfunction indicator fitted to the vehicle is activated when the malfunction listed in Table 1 of Appendix 3 occurs:
2.6.1.1.	During the same key cycle and;
2.6.1.2.	Immediately after expiration of a limited time delay (300 s or less) in that same key cycle; or
2.6.2.	Monitoring of some of the items listed in Table 1 of this Appendix is physically not possible and a deficiency has been granted for this incomplete monitor. The comprehensive, technical justification why such an OBD monitor cannot run shall be added to the application document and Agreed to the satisfaction of the test agency.
<b>APPENDIX 4 TO CHAPTER 7</b>	
<b>TEST TYPE VIII REQUIREMENTS: OBD ENVIRONMENTAL TESTS</b>	
<b>1.0</b>	<b>Introduction</b>
1.1.	This Appendix describes the procedure for type VIII testing on environmental onboard diagnostics (OBD). The procedure describes methods for checking the function of the OBD system on the vehicle by simulating failure of emission-relevant components in the powertrain management system and emission-control system.
1.2.	The manufacturer shall make available the defective components or electrical devices to be used to simulate failures. When measured over the test type I cycle, such defective components or devices shall not cause the vehicle emissions to exceed by more than 20 percent the OBD threshold limits set out in the notification. For failures (circuit continuity/circuit rationality/basic monitoring requirement), the emissions may exceed the OBD threshold limits by more than 20 percent.
1.3.	When the vehicle is tested with the defective component or device fitted, the OBD system shall be certified if the malfunction indicator is activated.



		The system shall also be certified if the malfunction indicator is activated below the OBD threshold limits.
	2.0	The test procedures in this Appendix shall be mandatory for vehicles equipped with an OBD system. This obligation concerns compliance with all provisions of this Appendix.
	3.0	Description of tests
	3.1.	Test vehicle
	3.1.1.	The environmental OBD verification and demonstration tests shall be carried out on a test vehicle, that shall be properly maintained and used, dependent on the chosen durability test method using the test procedures set-out in this Appendix and in the applicable Indian Driving Cycle (IDC) set out in Chapter 2.
	3.1.2.	In case of applying the durability test procedure, the test vehicles shall be equipped with the aged emission components used for durability tests as well as for the purposes of this Appendix and the OBD environmental tests shall be finally verified and reported at the conclusion of the durability testing. At the request of the manufacturer, a suitable aged and representative vehicle may be used for these OBD demonstration tests.
	3.1.3.	In case the OBD demonstration test requires emission measurements, the type VIII test shall be carried out on the test vehicles used for the durability test. Type VIII tests shall be finally verified and reported at the conclusion of the durability testing.
	3.1.4.	In case of applying the fixed deterioration factors (DF) set out in the notification, the applicable deterioration factors shall be multiplied with the emission test results. If the test agency allows, in case of misfire demonstration, alternatively experimentally determined deterioration factors from the durability test may be used. This demo method may be used to avoid damage during misfire testing to the deteriorated catalyst created by durability testing and may be used on request of the manufacturer if it submits data and/or an engineering evaluation which adequately demonstrates to the test agency the risk of damage to the deteriorated catalyst.
	3.1.5.	Reserved
	3.2.	(a) The OBD system shall indicate the failure of an emission-related component or system when that failure results in emissions exceeding the OBD threshold limits in the notification.  (b) A manufacturer may require in addition that the OBD system shall indicate the failure of any powertrain fault that triggers an operation mode that significantly reduces torque in comparison with normal operation
	3.3.	Reserved
	3.4.	Reserved
	3.4.1.	Reserved

	3.4.2.	Reserved
	4.0	OBD environmental test procedure
	4.1.	The testing of OBD systems consists of the following phases:
	4.1.1.	Simulation of malfunction of a component of the powertrain management or emission-control system;
	4.1.2.	Preconditioning of the vehicle (in addition to the preconditioning specified in Chapter 2) with a simulated malfunction that will lead to the OBD threshold limits being exceeded.
	4.1.3.	Driving the vehicle with a simulated malfunction over the applicable type I test cycle and measuring the tailpipe emissions of the vehicle ;
	4.1.3.1.	For OVC vehicles, the pollutant emissions shall be measured under the same conditions as specified for Condition B of the type I test
	4.1.3.2.	For NOVC vehicles, the pollutant emissions shall be measured under the same conditions as in the type I test;
	4.1.4.	Determining whether the OBD system reacts to the simulated malfunction and alerts the vehicle driver to it in an appropriate manner.
	4.2.	Alternatively, at the request of the manufacturer, malfunction of one or more components may be electronically simulated in accordance with the requirements laid down in Clause 8 of this Appendix.
	4.3.	Manufacturers may request that monitoring take place outside the type I test cycle if it can be demonstrated to the test agency that the monitoring conditions of the type I test cycle would be restrictive when the vehicle is used in service.
	4.4.	For all demonstration testing, the Malfunction Indicator (MI) shall be activated before the end of the test cycle.
	5.0	Test Vehicle and Test Fuel
	5.1.	Test Vehicle The test vehicles shall meet the requirements of Chapter 2. The manufacturer shall set the system or component for which detection is to be demonstrated at or beyond the criteria limit prior to operating the vehicle over the emissions test cycle appropriate for the classification of the vehicle. To determine correct functionality of the diagnostic system, the test vehicle shall then be operated over the type I test cycle.
	5.2.	Test fuel The reference fuel to test the vehicle shall be as specified in the notification and be of the same specification as the reference fuel used to conduct the type I tailpipe emissions after cold start. The selected fuel type shall not be changed during any of the test phases.
	6.0	Test temperature and pressure
	6.1.	The test temperature and ambient pressure shall meet the requirements of the type I test as set out in Chapter 2.

	7.0	Test equipment
	7.1.	Chassis dynamometer The chassis dynamometer shall meet the requirements of Chapter 2.
	8.0	OBD environmental verification test procedures
	8.1.	The operating test cycle on the chassis dynamometer shall meet the requirements of Chapter 2.
	8.1.1.	The Type I test need not be performed for the demonstration of electrical failures (short/open circuit). The manufacturer may demonstrate these failure modes using driving conditions in which the component is used and the monitoring conditions are encountered. Those conditions shall be documented in the certification documentation.
	8.2.	Vehicle preconditioning
	8.2.1.	According to the propulsion type and after introduction of one of the failure modes referred to in Clause 8.3. of this Appendix, the vehicle shall be preconditioned by driving at least two consecutive type I tests. For vehicles equipped with a compression ignition engine, additional preconditioning of two type I test cycles is permitted.
	8.2.2.	At the request of the manufacturer, alternative preconditioning methods may be used.
	8.2.3.	The use of additional preconditioning cycles or alternative preconditioning methods shall be documented in the certification documentation.
	8.3.	Failure modes to be tested.
	8.3.1.	For positive-ignition propelled vehicles:
	8.3.1.1.	Replacement of the catalytic converter type with a deteriorated or defective catalytic converter or electronic simulation of such a failure,
	8.3.1.2.	An induced misfire condition (i.e. by faulty component(s) or electronic simulation of such a failure) in line with those for misfire monitoring referred to in clause 1.1.4.2. of Appendix 1 <del>7</del> to this chapter that result in emission of any components exceeding any of the applicable OBD threshold limits given in the notification;
	8.3.1.3.	Replacement of the oxygen sensor with a deteriorated or defective sensor or electronic simulation of such a failure;
	8.3.1.4.	Electrical disconnection of any other emission-related component connected to a powertrain control unit / engine control unit (if active on the selected fuel type) in the scope of Appendix 3 of this Chapter;
	8.3.1.5.	Electrical disconnection of the electronic evaporative purge control device (if equipped and if active on the selected fuel type). For this specific failure mode, the type I test need not be performed.
	8.3.2.	For vehicles equipped with a compression-ignition (CI) engine:

	8.3.2.1.	Replacement of the catalytic converter type, where fitted, with a deteriorated or defective catalytic converter or electronic simulation of such a failure.
	8.3.2.2.	Total removal of the particulate filter, where fitted, or, where sensors are an integral part of the filter, a defective filter assembly;
	8.3.2.3.	Electrical disconnection or shorted circuit of any electronic fuel quantity and timing actuator in the fuelling system;
	8.3.2.4.	(a) Electrical disconnection of any other emission-related component connected to any control unit of the powertrain, the propulsion units or the drive train;  (b) A manufacturer may require in addition that electrical disconnection of any other functional safety-relevant component connected to any control unit of the powertrain, the propulsion units or the drive train;
	8.3.2.5.	The manufacturer shall take appropriate steps to demonstrate that the OBD system will indicate a fault when one or more of the faults occur listed in Appendix 3;
	8.3.3.	The manufacturer shall demonstrate that malfunctions of the EGR flow and cooler, where fitted, are detected by the OBD system during its approval test.
	8.3.4.	A manufacturer may require that any powertrain malfunction that triggers any operating mode which significantly reduces engine torque (i.e. by 10 % or more in normal operation) shall be detected and reported by the powertrain / engine control system.
	8.4.	OBD system environmental verification tests
	8.4.1.	Vehicles fitted with Positive Ignition (PI) engines:
	8.4.1.1.	After vehicle preconditioning in accordance with Clause 8.2. of this Appendix, the test vehicle is driven over the Type I test.  The malfunction indicator shall activate before the end of this test under any of the conditions given in clauses 8.4.1.2. to 8.4.1.6. The MI may also be activated during preconditioning. The test agency may substitute those conditions with others in accordance with clause 8.4.1.6. However, the total number of failures simulated shall not exceed four for the purpose of certification.  For bi-fuelled gas vehicles, both fuel types shall be used within the maximum of four simulated failures at the discretion of the test agency.
	8.4.1.2.	Replacement of a catalytic converter type with a deteriorated or defective catalytic converter or electronic simulation of a deteriorated or defective catalytic converter that results in emissions exceeding the NO <sub>x</sub> OBD threshold limit, in the notification
	8.4.1.3.	An induced misfire condition in line with those for misfire monitoring referred to in clause 1.1.4.3. of Appendix 1 to this chapter that results in emissions of any components exceeding any of the applicable OBD threshold limits given in the notification;

8.4.1.4.	Replacement of an oxygen sensor with a deteriorated or defective oxygen sensor or electronic simulation of a deteriorated or defective oxygen sensor that results in emissions exceeding any of OBD threshold limits in the notification;
8.4.1.5.	Electrical disconnection of the electronic evaporative purge control device (if equipped and if active on the selected fuel type);
8.4.1.6.	(a) Electrical disconnection of any other emission-related powertrain component connected to a powertrain control unit / engine control unit / drive train control unit that results in emissions exceeding any of the OBD threshold limits in the notification. (b) A manufacturer may require in addition that triggers an operation mode with significantly reduced torque as compared with normal operation.
8.4.2.	Vehicles fitted with compression-ignition (CI) engines:
8.4.2.1.	After vehicle preconditioning in accordance with Clause 8.2. of this Appendix, the test vehicle is driven in the applicable type I test.  The malfunction indicator shall activate before the end of this test under any of the conditions in clauses 8.4.2.2. to 8.4.2.5. The test agency may substitute those conditions by others in accordance with clause 8.4.2.5. However, the total number of failures simulated shall not exceed four for the purposes of certification.
8.4.2.2.	Replacement of a catalytic converter type, where fitted, with a deteriorated or defective catalytic converter or electronic simulation of a deteriorated or defective catalytic converter that results in emissions exceeding NOx OBD threshold limits in the notification.
8.4.2.3.	Total removal of the particulate filter, where fitted, or replacement of the particulate filter with a defective particulate filter meeting the conditions laid down in clause 8.4.2.2. that results in emissions exceeding any of the OBD threshold limits in the notification;
8.4.2.4.	With reference to clause 8.3.2.5., disconnection of any electronic fuel quantity and timing actuator in the fuelling system that results in emissions of any components exceeding any of the applicable OBD threshold limits in the notification;
8.4.2.5.	(a) With reference to clause 8.3.2.4., disconnection of any other powertrain component connected to a powertrain control unit / engine control / drive train control unit that results in emissions of any components exceeding any of the applicable OBD threshold limits in the notification. (b) A manufacturer may require in addition that disconnection of any other powertrain component connected to a powertrain control unit / engine control / drive train control unit that results in triggering of an operation mode with a significantly reduced torque as compared with normal operation.
8.4.3.	Replacement of the NOx after-treatment system, where fitted, with a deteriorated or defective system or electronic simulation of such a failure.

	8.4.4.	Replacement of the particulate matter monitoring system, where fitted, with a deteriorated or defective system or electronic simulation of such a failure.
<b>APPENDIX 5 TO CHAPTER 7</b>		
<b>ADMINISTRATIVE PROVISIONS</b>		
	<b>1.0</b>	The vehicle manufacturer shall fill out the information and submit to the test agency with regard to functional on-board diagnostics and test Type VIII according to the following template.
	<b>2.0</b>	Where documents, diagrams or long descriptions are required the vehicle manufacturer shall attach those as a separate file, appropriately marked in a clear and understandably system and the marking shall be written / typed for all sheets in the space provided.  The following data shall be provided by the vehicle manufacturer.
	2.1.	On-board diagnostics (OBD) functional requirements
	2.1.1.	<b>OBD system general information</b>
	2.1.1.1.	Written description or drawing of the Malfunction Indicator (MI);
	2.1.2.	<b>List and purpose of all components monitored by the OBD system:</b>
	2.1.2.1.	Written description (general working principles) for all OBD stage II circuit (open circuit, shorted low and high, rationality) and electronics (PCU / ECU internal and communication) diagnostics which triggers a default mode in case of fault detection;
	2.1.2.2.	Written description (general working principles) for all OBD stage II diagnostic functionality triggering any operating mode which triggers a limp home mode in case of fault detection;
	2.1.2.3.	Written description of the communication protocol(s) supported;
	2.1.2.4.	Physical location of diagnostic-connector (add drawings and photographs);
	2.1.2.5.	Other components than the ones listed in Table 1 of Appendix 3 of this chapter monitored by the OBD system;
	2.1.2.6.	Criteria for MI activation (fixed number of driving cycles or statistical method);
	2.1.2.7.	List of all OBD output codes and formats used (with explanation of each);
	2.1.2.8.	OBD compatibility for repair information  The following additional information shall be provided by the vehicle manufacturer to enable the manufacturer of OBD-compatible replacement or service parts, diagnostic tools and test equipment;
	2.1.2.9.	A description of the type and number of the pre-conditioning cycles used for the original approval//certification of the vehicle.
	2.1.2.10.	A comprehensive document describing all sensed components concerned with the strategy for fault detection and MI activation (fixed number of driving cycles or statistical method). This shall, include a list of relevant secondary sensed parameters for each component monitored by the OBD system. The document shall also list all OBD output codes and formats

		(with an explanation of each) used in association with individual emission-related powertrain components and individual non-emission-related components, where monitoring the component is used to determine MI activation.																
2.1.2.11.		<p>The information required in Clauses 2.1.2.1. to 2.1.2.10. of this Appendix may be provided in table form as described in the following table;</p> <p style="text-align: center;"><b>Example OBD fault-code overview list</b></p> <p style="text-align: center;"><b>Table 1</b></p> <table border="1" style="margin-left: auto; margin-right: auto;"> <thead> <tr> <th style="writing-mode: vertical-rl; transform: rotate(180deg);">component</th> <th style="writing-mode: vertical-rl; transform: rotate(180deg);">Diagnostic trouble code</th> <th style="writing-mode: vertical-rl; transform: rotate(180deg);">Monitoring strategy</th> <th style="writing-mode: vertical-rl; transform: rotate(180deg);">Fault detection criteria</th> <th style="writing-mode: vertical-rl; transform: rotate(180deg);">MI activation criteria</th> <th style="writing-mode: vertical-rl; transform: rotate(180deg);">Secondary parameters</th> <th style="writing-mode: vertical-rl; transform: rotate(180deg);">Preconditioning</th> <th style="writing-mode: vertical-rl; transform: rotate(180deg);">Demonstration test</th> </tr> </thead> <tbody> <tr> <td>Intake air temp. sensor open circuit</td> <td>P0xx xxxx</td> <td>Comparison with temperature model after cold start</td> <td>&gt; 20 degrees difference between measured and modelled intake air temperature</td> <td>3<sup>rd</sup> cycle</td> <td>Coolant and intake air temperature sensor signals</td> <td>Two type I cycles</td> <td>Type I</td> </tr> </tbody> </table>	component	Diagnostic trouble code	Monitoring strategy	Fault detection criteria	MI activation criteria	Secondary parameters	Preconditioning	Demonstration test	Intake air temp. sensor open circuit	P0xx xxxx	Comparison with temperature model after cold start	> 20 degrees difference between measured and modelled intake air temperature	3 <sup>rd</sup> cycle	Coolant and intake air temperature sensor signals	Two type I cycles	Type I
component	Diagnostic trouble code	Monitoring strategy	Fault detection criteria	MI activation criteria	Secondary parameters	Preconditioning	Demonstration test											
Intake air temp. sensor open circuit	P0xx xxxx	Comparison with temperature model after cold start	> 20 degrees difference between measured and modelled intake air temperature	3 <sup>rd</sup> cycle	Coolant and intake air temperature sensor signals	Two type I cycles	Type I											
2.1.2.12.		Description of Electronic Throttle Control (ETC) diagnostic trouble codes;																
2.1.2.13.		Description of default modes and strategies in case of ETC failure;																
2.1.2.14.		<p>Communication protocol information</p> <p>The following information shall be referenced to a specific vehicle make, model and variant, or identified using other workable definitions such as the Vehicle Identification Number (VIN) or vehicle and systems identification:</p>																
2.1.2.14.1.		Any protocol information system needed to enable complete diagnostics in addition to the standards prescribed in Clause 3.8. of Appendix 2 of this Chapter, such as additional hardware or software protocol information, parameter identification, transfer functions, "keep alive" requirements, or error conditions;																
2.1.2.14.2.		Details of how to obtain and interpret all diagnostic trouble codes not in accordance with the standards prescribed in Clause 3.11. of Appendix 2 of this Chapter;																
2.1.2.14.3.		A list of all available live data parameters including scaling and access information;																
2.1.2.14.4.		A list of all available functional tests including device activation or control and the means to implement them;																
2.1.2.14.5.		Details of how to obtain all component and status information, time stamps, pending DTC and freeze frames;																

	2.1.2.14.6.	Resetting adaptive learning parameters, variant coding and replacement component setup, and customer preferences;	
	2.1.2.14.7.	PCU / ECU identification and variant coding;	
	2.1.2.14.8.	Details of how to reset service lights;	
	2.1.2.15.	Location of diagnostic connector and connector details;	
	2.1.2.16.	Engine code identification;	
	2.1.2.17.	Test and diagnosis of OBD monitored components:	
	2.1.2.17.1.	A description of tests to confirm its functionality, at the component or in the harness;	
	2.1.2.17.2.	Test procedure including test parameters and component information;	
	2.1.2.17.3.	Connection details including minimum and maximum input and output and driving and loading values;	
	2.1.2.17.4.	Values expected under certain driving conditions including idling;	
	2.1.2.17.5.	Electrical values for the component in its static and dynamic states;	
	2.1.2.17.6.	Failure mode values for each of the above scenarios;	
	2.1.2.17.7.	Failure mode diagnostic sequences including fault trees and guided diagnostics elimination.	
	2.1.3.	On-board diagnostics environmental test Type VIII requirements	
	2.1.3.1.	Details of test vehicle(s), its powertrain and pollution-control devices explicitly documented and listed, emission test laboratory equipment and settings.	
23.0	<b>Page No. 207/244 to 210/244, Chapter 8, Table for “Classification criteria description for Test Type VIII”</b>		
	Insert the following text (for Stage II) :		
	<b>Classification criteria propulsion family with regard to on-board diagnostics</b>		
	1.0	A vehicle in the scope of this standard may continue to be regarded as belonging to the same vehicle propulsion family with regard to on-board diagnostics provided that the vehicle parameters in Table of Chapter 7 (Type test VIII – Stage II) and vehicle parameters referred in clause no. 2.3 & 2.4 of Appendix 2.7 are identical and remain within the prescribed and declared tolerances.	
	2.0	A representative parent vehicle shall be selected within the boundaries set by the classification criteria laid down in Table of Chapter 7 (Type test VIII – Stage II) and vehicle parameters referred in clause no. 2.3 & 2.4 of Appendix 2.7.	
	#	<b>Classification criteria description</b>	<b>Stage II</b>
	<b>1.0</b>	<b>VEHICLE</b>	
	1.1	Category	X



	1.2	Sub-category	X
	1.3	The inertia of a vehicle variant(s) or version(s) within two inertia categories above or below the nominal inertia category;	X
	1.4	Overall gear ratios (+/- 8 %);	X
	<b>2.0</b>	<b>PROPULSION FAMILY CHARACTERISTICS</b>	
	2.1	Number of engines	X
	2.2	Number of cylinders of the combustion engine;	X
	2.3	Engine capacity (+/- 30 %) of the combustion engine	X
	2.4	Number and control (variable cam phasing or lift) of combustion engine valves;	X
	2.5	Fuel system (carburettor / scavenging port / port fuel injection / direct fuel injection / common rail / pump-injector / other);	X
	2.6	Type of cooling system of combustion engine;	X
	2.7	Combustion cycle (PI / CI / two-stroke / four-stroke / other);	X
	2.8	Intake air system (naturally aspirated / charged (turbocharger / super-charger) / intercooler / boost control) and air induction control (mechanical throttle / electronic throttle control / no throttle);	X
	3.0	<b>Pollution Control System Characteristic</b>	
	3.1.	Operation principle of cold start or starting aid device(s);	X
	3.2.	Activation time of cold start or starting aid device(s); and / or duty cycle (only limited time activated after cold start / continuous operation)	X
	3.3.	Propulsion unit (not) equipped with O2 sensor for fuel control;	X
	3.4.	O <sub>2</sub> exhaust sensor types;	X

	3.5.	Operation principle of O <sub>2</sub> exhaust sensor (binary / wide range / other);	X
	3.6.	O <sub>2</sub> exhaust sensor interaction with closed-loop fuelling system (stoichiometry / lean or rich operation);	X
<p>Note: In a vehicle model, which is previously approved for OBD parameter, if there is any change in OBD parameter, then the testing for the changed OBD parameter only needs to be conducted as mutually agreed between the test agency and vehicle manufacturer if manufacturer can prove that changed OBD parameter don't have any interaction with other OBD parameters.</p>			

PRINTED BY  
 THE AUTOMOTIVE RESEARCH ASSOCIATION OF INDIA  
 P.B. NO. 832, PUNE 411 004  
 ON BEHALF OF  
 AUTOMOTIVE INDUSTRY STANDARDS COMMITTEE  
 UNDER  
 CENTRAL MOTOR VEHICLE RULES – TECHNICAL STANDING COMMITTEE  
 SET-UP BY  
 MINISTRY OF ROAD TRANSPORT & HIGHWAYS  
 (DEPARTMENT OF ROAD TRANSPORT & HIGHWAYS)  
 GOVERNMENT OF INDIA  
 12<sup>th</sup> April 2022

**AUTOMOTIVE INDUSTRY STANDARD**

**Test Method,  
Testing Equipment and Related Procedures  
for Type Approval and Conformity of  
Production (COP) Testing of L5 Category  
Vehicles for Bharat Stage VI (BS VI)  
Emission Norms as per  
CMV Rules 115, 116 and 126**

PRINTED BY  
THE AUTOMOTIVE RESEARCH ASSOCIATION OF INDIA  
P.B. NO. 832, PUNE 411 004

ON BEHALF OF  
AUTOMOTIVE INDUSTRY STANDARDS COMMITTEE

UNDER  
CENTRAL MOTOR VEHICLE RULES – TECHNICAL STANDING COMMITTEE

SET-UP BY  
MINISTRY OF ROAD TRANSPORT & HIGHWAYS  
(DEPARTMENT OF ROAD TRANSPORT & HIGHWAYS)  
GOVERNMENT OF INDIA

February 2019

**Status chart of the Standard to be used by the purchaser for updating the record**

Sr. No.	Corrigenda	Amendment	Revision	Date	Remark	Misc.
<b>General Remarks:</b>						

## **INTRODUCTION**

In India, the mass emission norms based on Indian Driving Cycle (IDC) were notified under CMVR in 1989. The first mass emission norms for vehicles were enforced from 1<sup>st</sup> April 1991 for Gasoline vehicles and from 1<sup>st</sup> April 1992 for Diesel vehicles. Since then, progressively emission norms have been tightened.

Government of India has notified migration to Bharat Stage VI (BS VI) emissions norms for 2, 3 and 4 wheeled vehicles from 1<sup>st</sup> April 2020. For Agricultural Tractors, Construction Equipment Vehicles and Combine Harvesters (vehicles having power exceeding 37 kW) next stage emission norms Bharat Stage (CEV/TREM) – IV) are notified from 1<sup>st</sup> October 2020 and Bharat Stage (CEV/TREM) – V) from 1st April 2024. Test procedure for Type Approval and CoP for above emission norms shall be as per various parts of AIS-137, as applicable.

This Part 2 of AIS-137 prescribes Test Method, Testing Equipment and related procedures for Type Approval and Conformity of Production (COP) Testing of Vehicles of Category L5 as defined in AIS-053: / IS 14272 for BS VI emission norms as per CMV Rules 115, 116 and 126

While preparing this standard, considerable assistance has been taken from following regulations/documents:

While preparing this part, considerable assistance has been taken from the following,

- Commission delegated regulation (EU) No 134/2014 of 16 December 2013 supplementing Regulation (EU) No 168/2013 of the European Parliament and of the Council with regard to environmental and propulsion unit
- Regulation (EU) No 168/2013 of the European parliament and of the council of 15 January 2013 on the approval and market surveillance of two- or three-wheel vehicles and quadricycles
- Commission delegated regulation (EU) No 44/2014 of 21 November 2013 supplementing Regulation (EU) No 168/2013 of the European Parliament and of the Council with regard to the vehicle construction and general requirements for the approval of two- or three- wheel vehicles and Quadricycles
- Commission implementing regulation (EU) No 901/2014 of 18 July 2014 implementing Regulation (EU) No 168/2013 of the European Parliament and of the Council with regard to the administrative requirements for the approval and market surveillance of two- or three-wheel vehicles and Quadricycles

- Commission delegated regulation (EU) 2018/295 of 15 December 2017 amending Delegated Regulation (EU) No 44/2014, as regards vehicle construction and general requirements, and Delegated Regulation (EU) No 134/2014, as regards environmental and propulsion unit performance requirements for the approval of two- or three-wheel vehicles and Quadricycles
- AIS-007 - Information on Technical Specifications to be submitted by the Vehicle Manufacturer
- UN GTR No. 17 - Crankcase and evaporative emissions of L-category vehicles (ECE/TRANS/180/Add.17)
- Part XVIII : Details of Standards for Tailpipe Emissions from spark ignition engines (Petrol, CNG and LPG) and compression ignition engines (Diesel) vehicles and Test Procedures for Mass Emission Standards (Bharat Stage IV) for Three Wheeled Vehicles
- Government of India, Gazette Notification G.S.R. 889 (E) dated 16<sup>th</sup> September, 2016 regarding implementation of Bharat Stage VI (BS VI) emission norms for 2, 3 and 4 wheeled vehicles.

The Committee Composition for formulation of this standard is given in ANNEXURE II

After approval of the standard by SCOE, The Automotive Research Association of India, (ARAI), Pune, being the Secretariat of the AIS Committee, has published this standard. For better dissemination of this information ARAI may publish this standard on their web site.

\*\*\*\*\*

<b>TABLE OF CONTENTS</b>		
<b>CHAPTER &amp; APPENDIX NO.</b>	<b>DESCRIPTION</b>	<b>PAGE NO</b>
<b>CHAPTER 1</b>	<b>Overall requirements</b>	1/244
<b>CHAPTER 2</b>	<b>Type I tests - tailpipe emissions after cold start</b>	16/244
APPENDIX 1	Symbols and acronyms	58/244
APPENDIX 2	Technical specification of reference fuels	63/244
APPENDIX 3	Chassis dynamometer system	64/244
APPENDIX 4	Exhaust dilution system	72/244
APPENDIX 5	Classification equivalent inertia mass and running resistance.	84/244
APPENDIX 6	Driving cycles & gearshift procedure for type I tests.	86/244
APPENDIX 7	Road tests on vehicles equipped with two or more wheels on the powered axles for the determination of test bench settings.	88/244
APPENDIX 8	Type I test procedure for vehicles fueled with LPG, NG/bio methane, flex fuel H <sub>2</sub> NG vehicles	95/244
APPENDIX 9	Type I test procedure for vehicles equipped with periodically regenerating system.	99/244
APPENDIX 10	Cop procedure – technical requirements.	107/244
APPENDIX 11	Type I test procedure for hybrid category vehicles	114/244
<b>CHAPTER 3</b>	<b>Type II tests - tailpipe emissions at idle (for PI engines) and at free acceleration (for CI engines).</b>	125/244
<b>CHAPTER 4</b>	<b>Type III tests- emissions of crankcase gases and type IV tests – evaporative emissions.</b>	130/244
APPENDIX 1	Sealed housing for evaporation determination (SHED) test procedure	132/244
APPENDIX 1.1	Preconditioning requirements for a hybrid application before start of the shed test	142/244
APPENDIX 2	(A) Ageing test procedures for evaporative emission control devices	144/244
	(B) Alternate ageing test procedures for evaporative emission control devices	146/244
APPENDIX 3	Calibration of equipment for evaporative emission testing	149/244
APPENDIX 4	CoP for vehicles with evaporative emission control system	153/244

<b>CHAPTER 5</b>	<b>Type V tests – durability of pollution control devices.</b>	155/244
APPENDIX 1	Mileage accumulation test cycle	169/244
<b>CHAPTER 6</b>	<b>Test procedure for ON BOARD DIAGNOSTICS –I (OBD –I)</b>	172/244
APPENDIX 1	OBD specification table format -OBD I	177/244
APPENDIX 2	OBD flow chart application table format- OBD I	178/244
APPENDIX 3	Essential characteristics of the vehicle family-OBD I	179/244
APPENDIX 4	Minimum monitoring requirements for an On-Board Diagnostic (OBD) system Stage I	180/244
<b>CHAPTER 7</b>	<b>Test procedure for ON BOARD DIAGNOSTICS –II (OBD –II)</b>	184/244
APPENDIX 1	Functional aspects of OBD system-OBD II	192/244
APPENDIX 2	Essential characteristics of the vehicle family-OBD II	198/244
APPENDIX 3	Minimum monitoring requirements for an On-Board Diagnostic (OBD) system Stage II	199/244
<b>CHAPTER 8</b>	<b>Vehicle propulsion family with regard to environmental performance demonstration tests.</b>	204/244
<b>CHAPTER 9</b>	<b>Test type VII requirements: CO<sub>2</sub> emissions, fuel consumption, electric energy consumption and electric range</b>	211/244
APPENDIX 1	Method of measuring the carbon dioxide emissions, fuel consumption, electric energy consumption and driving range of vehicles powered by a hybrid electric powertrain	213/244
APPENDIX 1.1	Electrical energy device/RESSES state of charge (SOC) profile for an externally chargeable hybrid electric vehicle (OVC HEV) in a type vii test	236/244
APPENDIX 1.2	Method for measuring the electricity balance of the battery of OVC and NOVC HEV	237/244
APPENDIX 1.3	Method of measuring the electric range of vehicles powered by an electric powertrain only or by a hybrid electric powertrain and the OVC range of vehicles powered by a hybrid electric powertrain	239/244
<b>LIST OF ANNEXURES</b>		
ANNEXURE I	COMPOSITION OF AISC PANEL*	243/244
ANNEXURE II	COMMITTEE COMPOSITION*	244/244



## CHAPTER 1 OVERALL REQUIREMENTS

### 1.0 SCOPE

- 1.1 This part of the standard is applicable for three wheeled motor vehicles of category L5 as defined in AIS-053 / IS 14272 as amended from time to time, equipped with positive ignition engines, compression ignition engines including hybrids electric vehicles for Bharat Stage VI.
- 1.2 This part shall be read in conjunction with Govt. Gazette Notification G.S.R. 889 (E) dated 16<sup>th</sup> September, 2016 for BS VI and as amended from time to time. Unless otherwise specified in this Part, wherever words “the notification” have been used, shall mean this final gazette notification.

### 2.0 REFERENCE STANDARDS:

Following standards and documents as amended from time to time are necessary adjuncts to this standard.

- 2.1 AIS-053 – Automotive Vehicles – Types – Terminology.  
IS 14272 – Automotive vehicles – Types – Terminology.
- 2.2 AIS-000 - Administrative Procedure to deal with Corrigendum, Amendments or Revisions to AIS, TAP 115 /116, CMVR Notifications, IS and ISO standards, which are notified under CMVR.
- 2.3 AIS-017 -Procedure for Type Approval and Certification of Vehicles for Compliance to Central Motor Vehicles Rules.
- 2.4 IS 2 – Rules for rounding off numerical values.
- 2.5 IS 9211 - Specification for Terms and Definitions of Weights of Road Vehicles.
- 2.6 IS 14785 - Automotive Vehicles - Determination of Road-load Constants by Coast down Test Method.
- 2.7 AIS-102 (Part 1) -CMVR Type Approval for Hybrid Electric Vehicles.

### 3.0 DEFINITIONS

For the purposes of this Part the following definitions shall apply:

- 3.1.1 ‘**Actuator**’ means a converter of an output signal from a control unit into motion, heat or other physical state in order to control the powertrain, engine(s) or drive train;
- 3.1.2 ‘**Air intake system**’ means a system composed of components allowing the fresh air charge or air-fuel mixture to enter the engine and includes, if fitted, the air filter, intake pipes, resonator(s), the throttle body and the intake manifold of an engine;
- 3.1.3 ‘**Alternative fuel vehicle**’ means a vehicle designed to run on at least one type of fuel that is either gaseous at atmospheric temperature and pressure, or substantially non- mineral oil derived;

- 3.1.4 **‘Access’** means the availability of all emission-related OBD data including all fault codes required for the inspection, diagnosis, servicing or repair of emissions related parts of the vehicle, via the serial interface for the standard diagnostic connection;
- 3.2.1 **‘Bi-fuel vehicle’** means a vehicle with two separate fuel storage systems that is designed to run on only one fuel at a time. The simultaneous use of both fuels is limited in amount and duration;
- 3.2.2 **‘Bi-fuel gas vehicle’** means a bi fuel vehicle that can run on petrol and also on either LPG, NG/bio methane or hydrogen (gas mode);
- 3.2.3 **‘Boost control’** means a device to control the boost level produced in the induction system of a turbocharged or supercharged engine;
- 3.3.1 **‘Calculated load value’** means referring to an indication of the current airflow divided by peak airflow, where peak airflow is corrected for altitude, if available. This definition provides a dimensionless number that is not engine specific and provides the service technician with an indication of the proportion of engine capacity being used (with wide open throttle as 100 %);
- 3.3.2 **‘Carburettor’** means a device that blends fuel and air into a mixture that can be combusted in a combustion engine;
- 3.3.3 **‘Catalytic converter’** means an emission pollution control device which converts toxic by-products of combustion in the exhaust of an engine to less toxic substances by means of catalyzed chemical reactions;
- 3.3.4 **‘Catalytic converter type’** means a category of catalytic converters that do not differ as regards the following:
- number of coated substrates, structure and material;
  - type of catalytic activity (oxidizing, three-way, or of another type of catalytic activity);
  - volume, ratio of frontal area and substrate length;
  - catalytic converter material content;
  - catalytic converter material ratio;
  - cell density;
  - dimensions and shape;
  - thermal protection;
  - an inseparable exhaust manifold, catalytic converter and muffler integrated in the exhaust system of a vehicle or separable exhaust system units that can be replaced;
- 3.3.5 **‘Compression Ignition engine’ or ‘CI engine’** means a combustion engine working according to the principles of the ‘Diesel’ cycle;
- 3.3.6 **‘Conformity of Production’ (CoP)** means the ability to ensure that each series of products produced is in conformity with the specification, performance and marking requirements in the type-approval;

- 3.3.7 **‘Circuit discontinuity’** means disconnection of only those components (sensors/actuators) which are monitored by EMS / ECU / Computer, by physically removing corresponding connector or cutting / separating wire(s) of corresponding sensor or actuator;
- 3.3.8 **‘Cold-start device’** means a device that temporarily enriches the air/fuel mixture of the engine, thus assisting the engine to start;
- 3.3.9 **‘Communication protocol’** means a system of digital message formats and rules for messages exchanged in or between computing systems or units;
- 3.3.10 **‘Common rail’** means a fuel supply system to the engine in which a common high pressure is maintained;
- 3.3.11 **‘Crankcase emissions’** means emissions from spaces in or external to an engine which are connected to the oil sump crankcase by internal or external ducts through which gases and vapour can escape;
- 3.3.12 **‘Calibration’** of the powertrain / engine or drive train control unit means the application of specific set of data maps and parameters used by the control unit’s software to tune the vehicle’s powertrain / engine or drive train;
- 3.4.1 **‘Driving cycle’** consists of engine start-up, driving mode where a malfunction would be detected if present, and engine shut-off;
- 3.4.2 **‘Defeat device’** means any element of design which senses temperature, vehicle speed, engine speed and/or load, transmission gear, manifold vacuum or any other parameter for the purpose of activating, modulating, delaying or deactivating the operation of any part of the emission control and exhaust after-treatment system and which reduces the effectiveness of the emission control system under conditions which may reasonably be expected to be encountered in normal vehicle operation and use. Such an element of design may not be considered a defeat device if:
- a) The need for the device is justified in terms of protecting the engine against damage or accident and for safe operation of the vehicle; or
  - b) The device does not function beyond the requirements of engine starting; or
  - c) Conditions are substantially included in the Type I test procedures;
- 3.4.3 **‘Deficiency’** means, in respect of vehicle OBD systems, that up to two separate components or systems that are monitored contain temporary or permanent operating characteristics that impair the otherwise efficient OBD monitoring of those components or systems or do not meet all of the other detailed requirements for OBD. Vehicles may be type-approved, registered and sold with such deficiencies according to the requirements of Clause 4 of Chapter-7 (OBD II);

- 3.4.4 **‘Default mode’** refers to a case where the engine management controller switches to a setting that does not require an input from a failed component or system;
- 3.4.5 **‘Drive train’** means the part of the powertrain downstream of the output of the propulsion unit(s) that consists if applicable of the torque converter clutches, the transmission and its control, either a drive shaft or belt drive or chain drive, the differentials, the final drive and the driven wheel tyre (radius);
- 3.4.6 **‘Drive train control unit’** means the on-board computer that partly or entirely controls the drive train of the vehicle;
- 3.4.7 **‘Durability’** means the ability of components and systems to last so that the environmental performance as laid down in the notification for type I tests can still be met after a mileage as defined in Chapter-5, if the vehicle is used under normal or intended circumstances and serviced in accordance with the manufacturer’s recommendations;
- 3.5.1 **‘Electric range’** means the distance that vehicles powered by an electric powertrain only or by a hybrid electric powertrain with off-vehicle charging can drive electrically on one fully charged battery or other electric energy storage device as measured in accordance with the procedure set out in Appendix 3.3. to Chapter -9;
- 3.5.2 **‘Emission control system’** means the electronic engine management controller and any emission-related component in the exhaust or evaporative system which supplies an input to or receives an output from this controller;
- 3.5.3 **‘Engine capacity’ means’**
- (a) for reciprocating piston engines, the nominal engine swept volume;
  - (b) for rotary-piston (Wankel) engines, double the nominal engine swept volume;
- 3.5.4 **‘Engine control unit’** means the on-board computer that partly or entirely controls the engine or engines of the vehicle;
- 3.5.5 **‘Engine misfire’** means a lack of combustion in the cylinder of a positive-ignition engine due to the absence of spark, poor fuel metering, poor compression or any other cause;
- In terms of OBD monitoring, it is that percentage of misfires out of a total number of firing events (as declared by the manufacturer) that would result in emissions exceeding the limits given in the applicable Gazette Notification under CMVR or that percentage that could lead to an exhaust catalyst, or catalysts, overheating causing irreversible damage;
- 3.5.6 **‘Exhaust gas recirculation (EGR) system’** means part of the exhaust gas flow led back to or remaining in the combustion chamber of an engine in order to lower the combustion temperature;

- 3.5.7 **‘Engine crankcase’** means the spaces in or external to an engine which are connected to the oil sump by internal or external ducts through which gases and vapour can escape;
- 3.5.8 **‘Evaporative emissions’** means the hydrocarbon vapours lost from the fuel system of a vehicle other than those from exhaust emissions meaning the hydrocarbon vapours lost from the fuel tank and fuel supply system of a motor vehicle and not those from tailpipe emissions;
- 3.5.9 **‘Electronic throttle control’ (ETC)** means the control system consisting of sensing of rider input via the accelerator pedal or handle, data processing by the control unit(s), resulting actuation of the throttle and throttle position feedback to the control unit in order to control the air charge to the combustion engine;
- 3.5.10 **‘Exhaust emissions’** means tailpipe emissions of gaseous pollutants and particulate matter;
- 3.5.11 **‘Exhaust system’** means the combination of the exhaust pipe, the expansion box, the exhaust silencer and pollution control device(s), as applicable;
- 3.6.1 **‘Fuel trim’** refers to feedback adjustments to the base fuel schedule;
- 3.6.2 **‘Flex fuel H2NG’ vehicle’** means a flex fuel vehicle designed to run on different mixtures of hydrogen and natural gas or bio-methane;
- 3.6.3 **‘Fuel cell’** means a converter of chemical energy from hydrogen into electric energy for propulsion of the vehicle;
- 3.6.4 **‘Fuel feed system’** means the set of components including and between fuel storage and air-fuel blending or injecting device(s);
- 3.6.5 **‘Fuel tank breathing losses’** means hydrocarbon emissions caused by temperature changes in the fuel tank;
- 3.6.6 **‘Fuel tank’** means a type of energy storage system that stores the fuel;
- 3.6.7 **‘Flex fuel vehicle’** means a vehicle with one fuel storage system that can run on different mixtures of two or more fuels;
- 3.6.8 **‘Flex fuel biodiesel vehicle’** means a flex fuel vehicle that can run on mineral diesel or a mixture of mineral diesel and biodiesel;
- 3.6.9 **‘Free acceleration test’** means the test conducted by abruptly but not violently, accelerating the vehicle from idle to full speed with the vehicle stationary in neutral gear;
- 3.6.10 **‘Flex fuel ethanol vehicle’** means a flex fuel vehicle that can run on petrol or a mixture of petrol and ethanol up to an 85/100 per cent ethanol blend (E85/E100);
- 3.7.1 **‘Gross vehicle weight (GVW)’** Means the technically permissible maximum weight declared by the vehicle manufacturer. In case of the 3 wheeled vehicles designed to be coupled to a semi-trailer, the mass GVW to be taken into consideration when classifying that vehicle, shall be the maximum weight of the tractor in running order, plus the weight transferred to the tractor by the laden semi-trailer in static condition;

- 3.7.2 **‘Gaseous pollutant’** means the exhaust gas emissions of carbon monoxide (CO), oxides of nitrogen (NO<sub>x</sub>) expressed in nitrogen dioxide (NO<sub>2</sub>) equivalent, and hydrocarbons (HC);
- 3.8.1 **‘Hybrid vehicle (HV)’** means a vehicle with at least two different energy converters and two different energy storage systems (on vehicle) for the purpose of vehicle propulsion;
- 3.8.2 **‘Hybrid Electric Vehicle (HEV)’** means a vehicle that, including vehicles which draw energy from a consumable fuel only for the purpose of recharging the electrical energy /power storage device that, for the purpose of mechanical propulsion, draws energy from both of the following on-vehicle sources of stored energy/power:
- a) A consumable fuel;
  - b) A battery, capacitor, flywheel/generator or other electrical energy /power storage device ;
- 3.8.3 **‘Hot Soak losses’** means hydrocarbon emissions arising from the fuel system of a stationary vehicle after a period of driving (assuming a ratio of C<sub>1</sub>H<sub>2.20</sub>);
- 3.9.1 **‘Intercooler’** means a heat exchanger that removes waste heat from the compressed air by a charger before entering into the engine, thereby improving volumetric efficiency by increasing intake air charge density;
- 3.9.2 **‘Inlet conduit’** means the combination of the inlet passage and the intake pipe;
- 3.9.3 **‘Inlet passage’** means the passage for the intake of air within the cylinder, cylinder-head or crankcase;
- 3.9.4 **‘Intake pipe’** means a part connecting the carburettor or air-control system and the cylinder, cylinder-head or crankcase;
- 3.9.5 **‘Intake system’** means the combination of the inlet conduit and the intake silencer;
- 3.10.1 **‘Long-term fuel trim’** refers to much more gradual adjustments to the fuel calibration schedule which compensate for vehicle differences and gradual changes that occur over time;
- 3.10.2 **‘Lean NOX absorber’** means a storage of NO<sub>x</sub> fitted into the exhaust system of a vehicle which is purged by the release of a reactant in the exhaust flow;
- 3.10.3 **‘Limp-home’** means an operation mode triggered by the control system that restricts fuel quantity, intake air quantity, spark delivery or other powertrain control variables resulting in significant reduction of output torque or engine revolution or vehicle speed;
- 3.11.1 **‘Mass of the optional equipment’** means the mass of the equipment which may be fitted to the vehicle in addition to the standard equipment, in accordance with the manufacturer’s specifications;

- 3.11.2 **‘Maximum net power’** means the maximum output for that power measured under full engine load;
- 3.11.3 **‘Maximum torque’** means the maximum torque value measured under full engine load;
- 3.11.4 **‘Mesh size’** means the number of openings per (linear) inch of mesh;
- 3.11.5 **‘Mode switch’** means a mechanical switch which enables the user to select one of the operating modes available in the vehicle for example “economic mode”, “Power mode”, “EV mode”, “Engine Mode” etc;
- 3.11.6 **‘Mileage accumulation’** means a representative test vehicle or a fleet of representative test vehicles driving a predefined distance as set out in the notification in accordance with the test requirements of Chapter-5 to this standard;
- 3.11.7 **‘Mono-fuel vehicle’** means a vehicle that is designed to run primarily on one type of fuel;
- 3.11.8 **‘Mono-fuel gas vehicle’** means a vehicle that is designed primarily for permanent running on LPG or NG/bio methane or hydrogen, but may also have a petrol system for emergency purposes or starting only, where the petrol tank does not contain more than 3 (three) litres of petrol;
- 3.11.9 **‘Malfunction indicator (MI)’** means a visible that clearly informs the driver of the vehicle in the event of a malfunction
- 3.11.10 **‘Malfunction’** means the failure of an electric /electronic circuit referred to in Chapter 6;
- 3.12.1 **‘Non-exposed type of fuel tank’** means that the fuel tank, except the fuel tank cap, is not directly exposed to radiation of sunlight;
- 3.12.2 **‘Net power’** means the power obtained on the test bench at the end of the crankshaft or its equivalent at the speed laid down by the manufacturer, together with the accessories listed in AIS-137 Part 5. If the power can be measured only when a gearbox is attached to the engine, the efficiency of the gearbox shall be taken into account;
- 3.13.1 **‘Optional equipment’** means features that are not included in the standard equipment and may be fitted to a vehicle under the responsibility of the manufacturer;
- 3.13.2 **‘On-board diagnostic system (OBD)’** means an electronic system fitted on-board of a vehicle that has the capability of identifying the likely area of malfunction by means of fault codes stored in a computer memory which can be accessed by means of a generic scan tool;
- 3.13.3 **‘OVC range’** means the total distance covered during complete combined cycles run until the energy imparted by external charging of the battery (or other electric energy storage device) is depleted, as measured in accordance with the procedure described in Appendix 1.3. to Chapter -9;
- 3.13.4 **‘Opacity meter’** means an Instrument for continuous measurement of the light absorption coefficient of the exhaust gases emitted by vehicles;

- 3.14.1 **‘Parent vehicle’** means a vehicle that is representative of a propulsion family set out in Chapter-8;
- 3.14.2 **‘Particulate filter’** means a filtering device fitted in the exhaust system of a vehicle to reduce particulate matter from the exhaust flow;
- 3.14.3 **‘Particulate matter’** means components of the exhaust gas which are removed from the diluted exhaust gas at a maximum temperature of 52°C by means of the filters described in the test procedure for verifying average tailpipe emissions;
- 3.14.4 **‘Periodically regenerating system’** means a pollution control device such as a catalytic converter, particulate filter or any other pollution control device that requires a periodical regeneration process in less than 4000 km of normal vehicle operation;
- 3.14.5 **‘Pollution control device’** means those components of a vehicle that control or reduce tailpipe and/or evaporative emissions;
- 3.14.6 **‘Pollution control device type’** means a category of pollution-control devices that are used to control pollutant emissions and that do not differ in their essential environmental performance and design characteristics;
- 3.14.7 **‘Positive ignition engine’ or ‘PI engine’** means a combustion engine working according to the principles of the ‘Otto’ cycle;
- 3.14.8 **‘Powertrain control unit’** means a combined control unit of combustion engine(s), electric traction motors or drive train unit systems including the transmission or the clutch;
- 3.14.9 **‘Permanent emission default mode’** refers to a case where the engine management controller permanently switches to a setting that does not require an input from a failed component or system where such a failed component or system would result in an increase in emissions from the vehicle to a level above the limits given in the applicable Gazette Notification under CMVR, 1989;
- 3.14.10 **‘Propulsion unit performance type-approval’** of a vehicle means the approval of a vehicle type, variant or version with regard to the performance of the propulsion units as regards the following conditions:
- the maximum design vehicle speed(s);
  - the maximum continuous rated torque or maximum net torque;
  - the maximum continuous rated power or the maximum net power;
  - the maximum total torque and power in the case of a hybrid application;
- 3.14.11 **‘Permanent default mode’** refers to a case where the engine management controller permanently switches to a setting that does not require an input from a failed component or system;



- 3.14.12 **‘Properly maintained and used’** means that when selecting a test vehicle it satisfies the criteria with regard to a good level of maintenance and normal use according to the recommendations of the vehicle manufacturer for acceptance of such a test vehicle;
- 3.14.13 **‘Propulsion’** means a combustion engine, an electric motor, any hybrid application or a combination of those engine types or any other engine type;
- 3.14.14 **‘Power take-off unit’** means an engine-driven output provision for the purposes of powering auxiliary, vehicle mounted and equipment;
- 3.15.1 **‘Rechargeable energy storage system (REESS)’** means the rechargeable energy storage system that provides electric energy for electrical propulsion. The REESS may include subsystem(s) together with the necessary ancillary systems for physical support, thermal management, electronic control and enclosures;
- 3.15.2 **‘Reference mass’** means the kerb mass determined in accordance with IS 9211 : 2003 increased by a uniform figure of 150 kg and if applicable, plus the mass of the propulsion battery;
- 3.15.3 **‘Repair information’** means all information required for diagnosis, servicing, inspection, periodic monitoring or repair of the vehicle and which the manufacturers provide for their authorized dealers/repair shops or for manufacturers of replacement or retrofit components which are compatible with the vehicle OBD system. Where necessary, such information shall include service handbooks, technical manuals, diagnosis information (e.g. minimum and maximum theoretical values for measurements), wiring diagrams, the software calibration identification number applicable to a vehicle type, instructions for individual and special cases, information provided concerning tools and equipment, data record information and bi-directional conformity and test data. The manufacturer shall also make accessible, where appropriate on payment, the technical information required for the repair or maintenance of motor vehicles unless that information is covered by an intellectual property right or constitutes essential, secret know-how which is identified in an appropriate form; in such case, the necessary technical information shall not be withheld improperly;
- 3.16.1 **‘Secondary air’** means air introduced into the exhaust system by means of a pump or aspirator valve or other means intended to aid in the oxidation of HC and CO contained in the exhaust gas flow;
- 3.16.2 **‘Sensor’** means a converter that measures a physical quantity or state and converts it into an electric signal that is used as input to a control unit;
- 3.16.3 **‘Series mounted equipment’** means all equipment intended by the manufacturer for a specific application;
- 3.16.4 **‘Short-term fuel trim’** refers to dynamic or instantaneous adjustments to the base fuel schedule;

- 3.16.5 **‘Scavenging port’** means a connector between crankcase and combustion chamber of a two-stroke engine through which the fresh charge of air, fuel and lubrication oil mixture enters the combustion chamber;
- 3.16.6 **‘Spark delivery of the ignition system’** means all the characteristics of the spark generated in the ignition system of a positive ignition ‘(PI)’ engine used to ignite the air-fuel mixture, such including timing, level and positioning;
- 3.16.7 **‘Standardised data’** means that all data stream information, including all fault codes used, shall be produced only in accordance with industry standards which, by virtue of the fact that their format and their permitted options are clearly defined, provide for a maximum level of harmonization in the motor vehicle industry, and whose use is expressly permitted in this part;
- 3.16.8 **‘Standard equipment’** means the basic configuration of a vehicle equipped with all the features required under the regulatory acts referred to in CMVR, including all features that are fitted without giving rise to any further specifications on configuration or equipment level;
- 3.16.9 **‘Stop-start system’** means automatic stop and start of the propulsion unit to reduce the amount of idling, thereby reducing fuel consumption, pollutant and CO<sub>2</sub> emissions of the vehicle;
- 3.16.10 **‘Super-charger’** means an intake air compressor used for forced induction of a combustion engine, thereby increasing propulsion unit performance;
- 3.16.11 **‘SCR system’** means a system capable of converting gaseous pollutants into harmless or inert gases by injecting a consumable reagent, which is a reactive substance to reduce tailpipe emissions and which is adsorbed onto a catalytic converter;
- 3.16.12 **‘SHED test’** means a vehicle test in a sealed house for evaporation determination, in which a special evaporative emission test is conducted;
- 3.16.13 **‘Starting aid’** means a device which assists engine start up without enrichment of the air/fuel mixture such as glow plugs, injection timing and spark delivery adaptations;
- 3.16.14 **‘Smoke density’** means the light absorption coefficient of the exhaust gases emitted by the vehicle expressed in terms of m<sup>-1</sup> or in other units such as Bosch, Hartridge, percent opacity etc.;
- 3.16.15 **‘Software’** of the powertrain / engine or drive train control units means a set of algorithms concerned with the operation of powertrain, engine or drive train data processing systems, containing an ordered sequence of instructions that change the state of the powertrain, engine or drive train control unit;
- ‘Software Identification Number’** refers to Calibration identification number;

- 3.16.16 **‘Significant reduction of propulsion torque’** means a propulsion torque less than or equal to 90 percent of torque in normal operation mode;
- 3.17.1 **‘Tailpipe emissions’** means the emission of gaseous pollutants and particulate matter at the tailpipe of the vehicle;
- 3.17.2 **‘Torque’** means the torque measured under the conditions specified in AIS-137 Part 5;
- 3.17.3 **‘Turbocharger’** means an exhaust gas turbine-powered centrifugal compressor boosting the amount of air charge into the combustion engine, thereby increasing propulsion unit performance;
- 3.18.1 **‘Useful life for evaporative system’** means the relevant period of distance and/or time over which compliance with the evaporative total hydrocarbon emission limits has to be assured;
- 3.18.2 **‘Useful life for OBD’** means the relevant period of distance and/or time over which compliance with the OBD system has to be assured;
- 3.18.3 **‘Unrestricted access to the OBD system’** means:
- (a) Access not dependent on an access code obtainable only from the manufacturer, or a similar device; or
  - (b) Access allowing evaluation of the data produced without the need for any unique decoding information, unless that information itself is standardized information;
- 3.18.4 **‘Unladen mass (kerb mass)’** means the mass of the vehicle in running order without crew, passengers or load, but with the fuel tank 90 percent full and the usual set of tools and spare wheel on board where applicable. In the case of 3 wheeled tractors, designed for coupling to a semi-trailer, the unladen mass will be that of the drawing vehicle;
- 3.19.1 **‘Vehicle propulsion unit family’** for the purpose of this part of the standard means a manufacturers grouping of vehicles which, through their design as defined in Chapter-8 of this standard, have similar Environmental and Propulsion Unit Performance characteristics;
- 3.19.2 **‘Vehicle type for OBD’** means a category of power-driven vehicles, which do not differ in such essential engine and OBD system characteristics as defined in Appendix 2 of Chapter-6 and 7;
- 3.19.3 **‘Vehicle family’** means a manufacturer's grouping of vehicles, which through their design, are expected to have similar exhaust emission and OBD system characteristics. Each engine of this family must have complied with the requirements of this part;
- 3.19.4 **‘Variable cam phasing or lift’** means allowing the lift, the opening and closing duration or timing of the intake or exhaust valves to be modified while the engine is in operation;

3.19.5 **‘Warm-up cycle’** means vehicle operation whereby the coolant temperature rises by at least 22°C from engine start-up to at least 70°C; If this condition is insufficient to determine the warm up cycle, with the permission of the approval authority, alternative criteria and/or alternative signal(s) or information (e.g. spark plug seat temperature, engine oil temperature, vehicle operation time, accumulative engine revolution, travel distance, etc.) may be adopted. In any case, all signal(s) and information used for determination need to be monitored by the ECU and shall be made available by data stream;

3.20 For definitions related to Type Approval terminologies i.e. base vehicle, vehicle type, variant(s) etc. the definitions given in AIS-017 as amended from time to time shall apply.

#### **4.0 REQUIREMENTS**

This part of the standard establishes the administrative and technical requirements for the type-approval of new types of vehicles, systems, components and separate technical units referred to in above clause 1 of this Chapter.

4.1 However, the test requirements are not applicable in petrol mode for a vehicle in the scope of this part that is designed primarily for permanent running on gaseous fuel, having a petrol system, with a petrol fuel tank capacity not exceeding three liters in the case of vehicles of L5 category, intended for emergency purposes or starting only or limp home mode.

4.2 The vehicles shall be manufactured to comply with the requirements specified in BSVI emission norms throughout the useful life specified therein when maintained as per the recommendations of the vehicle manufacturer. This requirement shall be deemed to be satisfied when the vehicles are tested for specified tests as per the procedures mentioned in Chapters to this Part.

4.3 For CNG and LPG vehicles, the provisions of CMV Rule 115(B) and CMV Rule 115(C), as amended from time to time shall apply respectively.

THC will be measured wherever NMHC/ RHC appear in this Part for BS VI.

4.4 AIS-137 (Part 5) specifies the method for measurement of performance such as net power at the end of the crankshaft or its equivalent at the corresponding engine or motor speed with the auxiliaries.

This method can be used to verify specific performance parameter against that claimed by manufacturers, as required for statutory purposes as part of type approval.

#### **5.0 APPLICATION FOR TYPE APPROVAL**

Application for Type Approval shall be submitted to the test agency along with following:-

5.1 Information to be submitted at the time of applying for type approval shall be as given in AIS-007 as amended from time to time.

In addition, the manufacturer shall submit the following information:

- (a) In the case of vehicles equipped with positive-ignition engines, a declaration by the manufacturer of the minimum percentage of misfires out of a total number of firing events that would either result in emissions exceeding the limits given in applicable Gazette Notification, if that percentage of misfire had been present from the start of a Type I test as described in Chapter 2 of this Part, or that could lead to an exhaust catalyst or catalysts, overheating prior to causing irreversible damage;
- (b) Detailed written information fully describing the functional operation characteristics of the OBD system, including a listing of all relevant parts of the emission control system of the vehicle that are monitored by the OBD system;
- (c) A description of the malfunction indicator used by the OBD system to signal the presence of a fault to a driver of the vehicle;
- (d) A description of the provisions taken to prevent tampering with and modification of the emission control computer;
- (e) If applicable, the particulars of the vehicle family as referred to in Chapter 8 of this Part;
- (f) Where appropriate, copies of other type approvals with the relevant data to enable extension of approvals and establishment of deterioration factors.

**Note:** If the above information is submitted in a consolidated form for type approval of the whole vehicle as per AIS-007 as amended from time to time, it is not necessary to submit this information again.

5.2 Number of vehicles to be submitted for Type approval shall be worked out by the manufacturer based on the family definition mentioned in Chapter-8 of this part.

5.3 This may also necessitate submission of vehicles of different variant (s) / for each test.

5.4 A copy of Owner's manual and service station manual shall be submitted to the test agency. Any changes to this document shall be communicated to the test agency from time to time.

**Note:** In case these publications are not available at the time of submitting the prototype vehicle, they shall be submitted by the manufacturer as and when they are ready but before first CoP. In case these publications are not available at the time of prototype testing, the relevant information required by the Testing Agency, shall be provided by the manufacturer.

## **6.0 TYPE APPROVAL**

6.1 If the vehicle submitted for approval pursuant to this part of the standard meets all the specified requirements, approval of that vehicle type shall be granted in the form as mentioned in AIS-017.

**7.0 EXTENSION OF TYPE APPROVAL**

7.1 Every functional modification in technical specifications pertaining to Environmental and Propulsion performance of vehicle declared as per AIS-007 (Rev. 5), as amended from time to time, for BS VI provisions shall be intimated to the test agency.

Test agency may then consider, whether,

7.1.1 Vehicle with modifications complies with specified requirements;

7.1.2 any testing is required.

7.2 For considering whether testing is required or not, guidelines given in Chapter 8 of this part shall be followed.

7.3 In case of 7.1.2, above checks for those parameters which are affected by the modifications only need to be carried out.

7.4 In the event of 7.1.1 or 7.1.2, above after successful compliance to requirements, the certificate of compliance shall be extended for the modified version.

7.5 In case these changes necessitate amendments in the Owners' manual and Service station manual, the amended copies shall be submitted to test agency.

7.6 Any changes to the procedure of PDI and running in concerning emission shall also be intimated to the test agency by the vehicle manufacturer, whenever such changes are carried out.

**8.0 TRANSITORY PROVISIONS (Refer AIS-000)**

8.1 At the request of the applicant, type approvals for compliance to BS VI norms as per CMVR no 115 (20) shall be granted by test agencies from date of the Notification. Such type approvals shall be deemed to be compliance to BS IV norms as per CMVR no 115 (17).

8.1.1 However, in such cases the extension of approval for design changes and Conformity of Production, if applicable, shall be as per BS VI norms as per CMVR no 115 (20).

8.2 At the request of applicant, type approval to BS IV norms as per CMVR no 115 (17) shall be granted up to the notified date of implementation of BS VI norms as per CMVR no 115 (20) of the notification.

8.3 Type approvals issued for compliance to BS IV norms as per CMVR No 115 (17) shall be extended for design changes till implementation date of BS VI norms as per CMVR no 115 (20) subject to satisfactory compliance.

8.4 Type approvals granted to OBD stage I as per CMVR no 115 (20) shall be extended for design changes till implementation date of OBD stage II.

**9.0 ESSENTIAL CHARACTERISTICS OF THE VEHICLE AND ENGINE AND INFORMATION CONCERNING THE CONDUCT OF TESTS:**

9.1 Information applicable to the vehicle category shall be provided as per respective Tables in AIS-007, as amended from time to time.

**Table 1**  
**Application of Test Requirements for Type-Approval : BS-VI**

	Vehicle with PI engines including hybrids						Vehicles with CI engines including hybrids					
	Mono-fuel					Bi-fuel <sup>(3)</sup>		Flex- fuel	Flex-fuel	Mono fuel	Dual Fuel	
	Gasoline (E5)	LPG	CNG/ Bio methane/ Bio-Gas/ LNG	H <sub>2</sub>	HCNG (Hydrogen + CNG)	Gasoline (E5)	Gasoline (E5)	Gasoline (E5)	Diesel (B7)	Diesel (B7)	Diesel + CNG	
LPG						CNG/Bio methane	Ethanol (E85)/	Bio-diesel up to 100% <sup>(1)</sup>				
<b>Gaseous pollutant (Type I test)</b>	Yes	Yes	Yes	Yes	Yes	Yes (both fuels)	Yes (both fuels)	Yes (both fuels)	Yes (both fuels)	Yes	Yes	
<sup>(2)</sup> <b>Type I test Particulate mass</b>	No	No	No	No	No	No	No	No	Yes (both fuels)	Yes	Yes	
<b>Idle emission (Type II Test)</b>	Yes	Yes	Yes	Yes	Yes	Yes (both fuels)	Yes (both fuels)	Yes (both fuels)	Yes (both fuels)	Yes	Yes	
<b>Crankcase emission (Type III test )</b>	Yes	Yes	Yes	Yes	Yes	Yes	Yes	Yes	Yes	Yes	Yes	
<b>Evaporative emission (Type IV test )</b>	Yes	No	No	Yes	Yes	Yes (gasoline only)	Yes (gasoline only)	Yes (gasoline only)	No	No	No	
<b>Durability (Type V test )</b>	Yes	Yes	Yes	Yes	Yes	Yes (gasoline only)	Yes (gasoline only)	Yes (gasoline only)	Yes (B7 only)	Yes	Yes	
<sup>(4)</sup> <b>CO<sub>2</sub> &amp; Fuel consumption</b>	Yes	Yes	Yes	No	No	Yes (both fuels)	Yes (both fuels)	Yes (both fuels)	Yes (both fuels)	Yes	Yes	
<b>OBD Stage II</b>	Yes	Yes	Yes			Yes (gasoline only)	Yes (gasoline only)	Yes (gasoline only)	Yes (B7 only)	Yes	Yes	
<b>Smoke Opacity</b>	No	No	No	No	No	No	No	No	Yes (B7 only)	No	No	

(1) Vehicles fuelled with bio diesel blends up to 7% (percent) shall be tested with reference diesel (B7) and vehicles fuelled with Bio diesel blends above 7 (percent) will be tested with respective blends.

(2) In case of PI engines, applicable only to vehicles with direct Injection engines.

(3) Vehicles models and variants having option for Bi-fuel operation and fitted with limp-home gasoline tank of capacity not exceeding three litres on three wheelers shall be exempted from test in gasoline mode.

(4) CO<sub>2</sub> emission and fuel consumption shall be measured as per procedure laid down in AIS-137 and as amended time to time.

When bi-fuel vehicle is combined with a flex fuel vehicle, both test requirements are applicable. Vehicle tested with E100 need not to be tested with E85.

## CHAPTER 2 TYPE I TESTS-TAILPIPE EMISSIONS AFTER COLD START

### 1.0 INTRODUCTION

- 1.1 This Chapter sets out the procedure for Type I testing of L5 Category vehicles as defined in AIS-053 / IS 14272 as amended from time to time, for verifying compliance to tailpipe emission norms for BS VI.

### 2.0 GENERAL REQUIREMENTS:

- 2.1 The components liable to affect the emission of gaseous pollutants, carbon dioxide emissions and fuel consumption shall be so designed, constructed and assembled so as to enable the vehicle in normal use, despite the vibration to which it may be subjected, to comply with the provisions of this Chapter.
- 2.2 Any hidden strategy that ‘optimizes’ the powertrain of the vehicle running the relevant emission laboratory test cycle in an advantageous way, reducing tailpipe emissions and running significantly differently under real-world conditions, is considered a defeat strategy and is prohibited, unless the manufacturer has documented and declared it to the satisfaction of the test agency.

### 3.0 PERFORMANCE REQUIREMENTS

- 3.1 The vehicle shall comply with the applicable limits as specified in the notification.

### 4.0 TEST CONDITIONS

#### 4.1 Test room and soak area

##### 4.1.1 Test room

The test room with the chassis dynamometer and the gas sample collection device shall have a temperature of  $25 \pm 5^{\circ}\text{C}$ . The room temperature shall be measured in the vicinity of the vehicle cooling blower (fan) before and after the type I test. The absolute humidity (H) of either the air in the test cell or the intake air of the engine shall be such that  $5.5 < H < 12.2$  g of  $\text{H}_2\text{O}/\text{kg}$  dry air.

##### 4.1.2 Soak area

The soak area shall have a temperature of  $25 \pm 5^{\circ}\text{C}$  and be such that the test vehicle to be preconditioned can be parked in accordance with following sub clauses.

#### 4.2 Test vehicle

##### 4.2.1 General

All components of the test vehicle shall conform to those of the production series or, if the vehicle is different from the production series, a full description shall be given in the test report. In selecting the test vehicle, the manufacturer and the test agency shall agree to which vehicle test model representative of vehicle propulsion family as laid down in Chapter 8 of this part.



#### 4.2.2 **Run-in**

The vehicle shall be presented in good mechanical condition, properly maintained and used. It shall have been run in and driven at least 1000 km before the test. The engine, drive train and vehicle shall be properly run in, in accordance with the manufacturer's requirements.

**Note:** If the manufacturer has carried out the run-in on a chassis dynamometer where the odometer does not get operated, a declaration by the manufacturer will be sufficient for the compliance to this clause. However, the test agency may seek for log data by the manufacturer.

#### 4.2.3 **Adjustments**

The test vehicle shall be adjusted in accordance with the manufacturer's requirements, e.g. as regards the viscosity of the oils or, if the test vehicle is different from the production series, a full description shall be given in the test report.

#### 4.2.4 **Test mass and load distribution**

The test mass, including the masses of the driver and the instruments, shall be measured before the beginning of the tests. The load shall be distributed across the wheels as specified by the manufacturer.

#### 4.2.5 **Tyres**

The tyres shall be of a type specified as original equipment by the vehicle manufacturer. The tyre pressures shall be adjusted to the specifications of the manufacturer or to those where the speed of the vehicle during the road test and the vehicle speed obtained on the chassis dynamometer are equalized.

The tyre pressure shall be indicated in the test report.

#### 4.3 **Specification of the reference fuel**

The reference fuel as prescribed in the notification shall be used. If the engine is lubricated by a fuel oil mixture, the oil added to reference fuel shall comply with the grade and quantity as per the manufacturer's recommendation. The same shall be reported and indicated in test report.

##### 4.3.1 **Test vehicle preconditioning**

###### 4.3.1.1 The test vehicle shall be moved to the test area and the following operations performed:

The fuel tanks shall be drained through the drains of the fuel tanks provided and charged with the test fuel as specified in the notification to half the capacity of the tanks.

The test vehicle shall be placed, either by being driven or pushed, on a dynamometer and operated through the applicable test cycle as specified in Appendix 6 of this chapter. The vehicle need not be cold, and may be used to set dynamometer power.

- 4.3.1.2 Practice runs over the prescribed driving schedule may be performed at test points, provided an emission sample is not taken, for the purpose of finding the minimum throttle action to maintain the proper speed-time relationship, or to permit sampling system adjustments.
- 4.3.1.3 Within five minutes of completion of preconditioning, the test vehicle shall be removed from the dynamometer and may be driven or pushed to the soak area to be parked. The vehicle shall be stored for between 6 and 36 hours prior to the cold start type I test or until the engine oil temperature ( $T_O$ ) or the coolant temperature ( $T_C$ ) or the sparkplug seat/gasket temperature ( $T_P$ ) (only for air-cooled engine) equals the air temperature of the soak area within  $\pm 2K$ .
- 4.3.1.4 For the purpose of measuring particulates, between 6 and 36 hours before testing, the applicable test cycle as per notification shall be conducted. The technical details of the test cycle are laid down in Appendix 6 of this chapter and the test cycle shall also be used for vehicle pre-conditioning. 6 consecutive cycles shall be driven. The dynamometer setting shall be indicated as in clause 4.4.5. or 5.2.2 of this chapter as applicable.
- In a test facility where a test on a low particulate emitting vehicle could be contaminated by residue from a previous test on a high particulate emitting vehicle, it is recommended that, in order to pre-condition the sampling equipment, the low particulate emitting vehicle undergo a 20 minute 120 km/h steady state drive cycle or at 70% of the maximum design speed for vehicles not capable of attaining 120 km/h followed by 6 consecutive cycles, if feasible.
- 4.3.1.5 After this preconditioning, and before testing, vehicles shall be kept in a room in which the temperature remains relatively constant between (293.20 K and 303.20 K) 20°C and 30°C. This conditioning shall be carried out for at least 6 hours and continue until the engine oil temperature and coolant, if any, are within  $\pm 2K$  of the temperature of the room.
- If the manufacturer so requests, the test shall be carried out not later than 30 hours after the vehicle has been run at its normal temperature.
- 4.3.1.6 Vehicles equipped with a positive-ignition engine, fueled with LPG, NG/biomethane, H<sub>2</sub>NG, hydrogen or so equipped that they can be fueled with either petrol, LPG, NG/biomethane, H<sub>2</sub>NG or hydrogen between the tests on the first gaseous reference fuel and the second gaseous reference fuel, shall be preconditioned before the test on the second reference fuel. At the manufacturer's request and with the agreement of the test agency, this preconditioning may be extended. The dynamometer setting shall be as indicated in clause 4.4.5 or 5.2.2 of this chapter.

#### 4.4 **Type I test**

##### 4.4.1 **Following types of Specifications and settings.**

##### 4.4.2 **Test bench specifications and settings**

- 4.4.2.1 The chassis dynamometer may have single roller or two rollers. In case of a single roller, the roller diameter of at least 400 mm.
- The dynamometer setting shall be as indicated in clause 4.4.5 or clause 5.2.2 of this Chapter.
- 4.4.2.2 The dynamometer shall be equipped with a roller revolution counter for measuring actual distance travelled.
- 4.4.2.3 It shall be equipped with means to simulate inertia and load. These simulators shall be connected to the front roller, in the case of a two roller dynamometer.
- 4.4.2.4 The dynamometer rollers shall be clean, dry and free from anything which might cause the tyres to slip.
- 4.4.2.5. The dynamometer shall be capable of simulating road load with adjustable load curve, i.e. a dynamometer with at least two road load parameters that can be adjusted to shape the load curve.
- 4.4.2.6. The setting of the dynamometer shall not be affected by the lapse of time. It shall not produce any vibrations perceptible to the vehicle and likely to impair the vehicle's normal operations.
- 4.4.2.7 Cooling fan specifications as follows
- 4.4.2.7.1 Throughout the test, a variable-speed cooling blower (fan) shall be positioned in front of the vehicle so as to direct the cooling air onto it in a manner that simulates actual operating conditions. The blower speed shall be such that, within the operating range of 10 to 50 km/h, the linear velocity of the air at the blower outlet is within  $\pm 5$  km/h of the corresponding roller speed. At the range of over 50 km/h, the linear velocity of the air shall be within  $\pm 10$  percent. At roller speeds of less than 10 km/h, air velocity may be zero.
- 4.4.2.7.2 The air velocity referred to in clause 4.4.2.7.1 of this Chapter shall be determined as an averaged value of nine measuring points which are located at the center of each rectangle dividing the whole of the blower outlet into nine areas (dividing both horizontal and vertical sides of the blower outlet into three equal parts). The value at each of the 9 points shall be within 10 percent of the average of the nine values.
- 4.4.2.7.3 The blower outlet shall have a cross-section area of at least  $0.4 \text{ m}^2$  and the bottom of the blower outlet shall be between 15 cm and 20 cm above floor level. The blower outlet shall be perpendicular to the longitudinal axis of the vehicle, between 30 cm and 45 cm in front of its front wheel. The device used to measure the linear velocity of the air shall be located in the middle of the stream at 20 cm from the air outlet.
- 4.4.2.8 The detailed requirements regarding test bench specifications are listed in Appendix 3 of this Chapter.
- 4.4.3 **Exhaust gas measurement system**
- 4.4.3.1 The gas-collection device shall be closed-type devices that can collect all exhaust gases at the vehicle exhaust outlets on condition that it satisfies the backpressure condition of  $\pm 125$  mm of  $\text{H}_2\text{O}$ . An open system may be used if it is confirmed that all the exhaust gases are

collected. The gas collection shall be such that there is no condensation which could appreciably modify the nature of exhaust gases at the test temperature. An example of a gas-collection device is illustrated in Figure 1 and Figure 2 of this chapter:

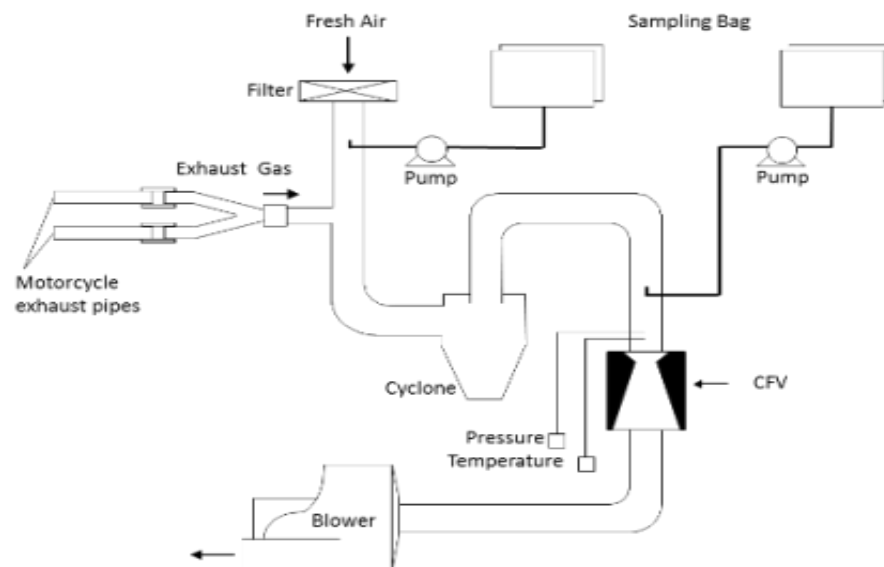

**Figure 1**

**closed-type system for sampling gases and measuring their volume**

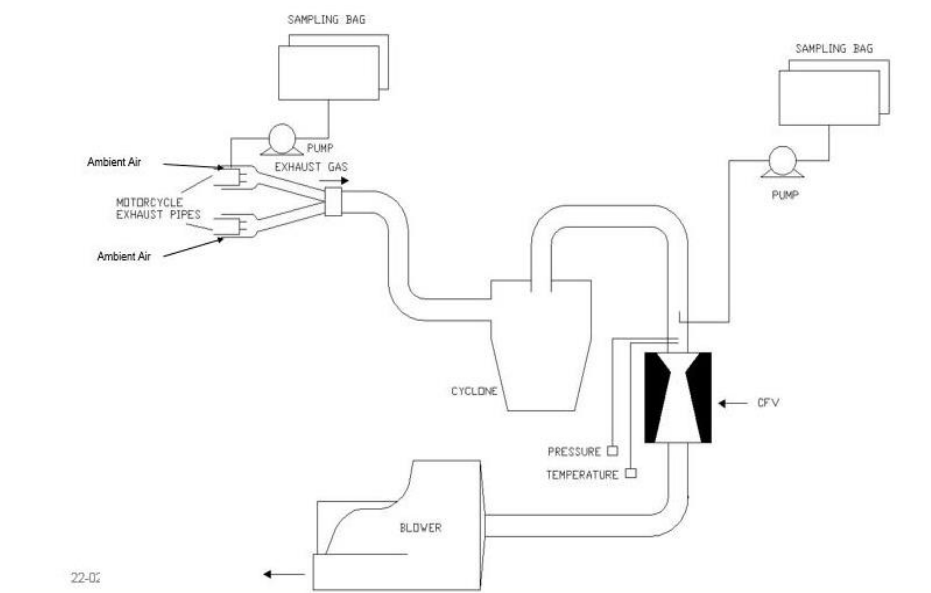

**Figure 2**

**open-type system for sampling gases and measuring their volume.**

- 4.4.3.2. A connecting tube shall be placed between the device and the exhaust gas sampling system. This tube and the device shall be made of stainless steel, or of some other material which does not affect the composition of the gases collected and which withstands the temperature of these gases.

- 4.4.3.3. A heat exchanger capable of limiting the temperature variation of the diluted gases in the pump intake to  $\pm 5^{\circ}\text{C}$  shall be in operation throughout the test. This exchanger shall be equipped with a preheating system capable of bringing the exchanger to its operating temperature (with the tolerance of  $\pm 5^{\circ}\text{C}$ ) before the test begins.
- 4.4.3.4. A positive displacement pump shall be used to draw in the diluted exhaust mixture. This pump shall be equipped with a motor with several strictly controlled uniform speeds. The pump capacity shall be large enough to ensure the intake of the exhaust gases. A device using a critical-flow venturi (CFV) may also be used.
- 4.4.3.5. A device (T) shall be used for the continuous recording of the temperature of the diluted exhaust mixture entering the pump.
- 4.4.3.6. Two gauges shall be used, the first to ensure the pressure depression of the dilute exhaust mixture entering the pump relative to atmospheric pressure, and the second to measure the dynamic pressure variation of the positive displacement pump.
- 4.4.3.7. A probe shall be located near to, but outside, the gas-collecting device, to collect samples of the dilution air stream through a pump, a filter and a flow meter at constant flow rates throughout the test.
- 4.4.3.8. A sample probe pointed upstream into the dilute exhaust mixture flow, upstream of the positive displacement pump, shall be used to collect samples of the dilute exhaust mixture through a pump, a filter and a flow meter at constant flow rates throughout the test. The minimum sample flow rate in the sampling devices shown in Figure 2 of this chapter and in clause 4.4.3.7 shall be at least 150 liter/hour.
- 4.4.3.9. Three-way valves shall be used on the sampling system described in clauses 4.4.3.7 and 4.4.3.8 of this chapter to direct the samples either to their respective bags or to the outside throughout the test.
- 4.4.3.10. Gas-tight collection bags
- 4.4.3.10.1. For dilution air and dilute exhaust mixture the collection bags shall be of sufficient capacity not to impede normal sample flow and shall not change the nature of the pollutants concerned.
- 4.4.3.10.2. The bags shall have an automatic self-locking device and shall be easily and tightly fastened either to the sampling system or the analyzing system at the end of the test.
- 4.4.3.11. A revolution counter shall be used to count the revolutions of the positive displacement pump throughout the test.
- Note:** Attention shall be paid to the connecting method and the material or configuration of the connecting parts, because each section (e.g. the adapter and the coupler) of the sampling system can become very hot. If the measurement cannot be performed normally due to heat damage to the sampling system, an auxiliary cooling device may be used as long as the exhaust gases are not affected.

**Note:** With open type devices, there is a risk of incomplete gas collection and gas leakage into the test cell. There shall be no leakage throughout the sampling period.

**Note:** If a constant volume sampler (CVS) flow rate is used throughout the test cycle that includes low and high speeds all in one (i.e. part 1, 2 and 3 cycles), special attention shall be paid to the higher risk of water condensation in the high speed range.

- 4.4.3.12. Particular requirements for compression ignition engines
- 4.4.3.12.1. A heated sample line for a continuous HC-analysis with the heated flame ionization detector (HFID), including recorder (R) shall be used.
- 4.4.3.12.2. The average concentration of the measured hydrocarbons shall be determined by integration. Throughout the test, the temperature of the heated sample line shall be controlled at  $(190^{\circ}\text{C} \pm 10^{\circ}\text{C})$   $463\text{K} \pm 10\text{K}$ . The heated sampling line shall be fitted with a heated filter (Fh) 99 % (percent) efficient with particle  $\geq 0.3 \mu\text{m}$  to extract any solid particles from the continuous flow of gas required for analysis.
- 4.4.3.12.3. The sampling system response time (from the probe to the analyser inlet) shall be not more than 4 s.
- 4.4.3.12.4. The HFID shall be used with a constant flow (heat exchanger) system to ensure a representative sample, unless compensation for varying CFV or CFO flow is made.
- 4.4.3.12.5. The particulate sampling unit consists of a dilution tunnel, a sampling probe, a filter unit, a partial flow pump, and a flow rate regulator and measuring unit. The particulate sampling part flow is drawn through two series mounted filters.

The sampling probe for the test gas flow for particulates shall be so arranged within the dilution tract that a representative sample gas flow can be taken from the homogenous air / exhaust mixture and an air / exhaust gas mixture temperature of  $52^{\circ}\text{C}$  shall not exceed immediately before the particulate filter.

The temperature of the gas flow in the flow meter shall not fluctuate more than  $\pm 3\text{K}$  ( $\pm 3^{\circ}\text{C}$ ), nor shall the mass flow rate fluctuate more than  $\pm 5$  percent.

If the volume of flow changes unexpectedly as a result of excessive filter loading, the test should be stopped. When it is repeated, the rate of flow shall be decreased and / or larger filter shall be used. The filters shall be removed from the chamber not earlier than an hour before the test begins.

- 4.4.3.12.6. The necessary particulate filters should be conditioned (as regards temperature and humidity) in an open dish which shall be protected against dust ingress for at least 8 hours and not more than 56 hours before the test in an air conditioned chamber. After this conditioning, the uncontaminated filters shall be weighed/read and stored until they are used in a dust free and vibration proof chamber.

The temperature of the chamber (or room) in which particulate filters are conditioned and weighed shall be maintained to within  $295\text{K} \pm 3\text{K}$  ( $22^{\circ}\text{C} \pm 3^{\circ}\text{C}$ ) during all filters conditioning and weighing. The humidity shall be maintained to a dew point of  $282.3\text{K} \pm 3\text{K}$  ( $9.5^{\circ}\text{C} \pm 3^{\circ}\text{C}$ ) and a relative humidity of 45 percent  $\pm$  8 percent.

4.4.3.12.7. If the filters are not used within 1 hour of their removal from the weighing chamber, then they shall be re-weighed. The 1hour limit shall be replaced by an 8-hour limit if one or both of the following conditions are met:

- i) A stabilized filter is placed and kept in a sealed filter holder assembly with the ends plugged, or
- ii) A stabilized filter is placed in a sealed filter holder assembly which is then immediately placed in a sample line through which there is no flow.

4.4.3.13. Additional sampling unit for the testing of vehicles equipped with a compression ignition engine.

4.4.3.13.1. The particulate sampling system consists of a sampling probe in the dilution tunnel and two series-mounted filters. Quick-acting are located both up and downstream of the two filters in the direction of flow.

The configuration of the sample probe shall be as indicated in Figure 6 of this Chapter.

4.4.3.13.2. Particulate matter (PM) sampling probe

4.4.3.13.2.1. The sample probe shall deliver the particle-size classification performance described in clause 4.4.3.13.2.4. of this chapter. It is recommended that this performance be achieved by the use of a sharp-edged, open-ended probe facing directly in the direction of flow, plus a pre-classifier (cyclone impactor etc.). An appropriate sampling probe, such as that indicated in Figure 6 of this chapter, may alternatively be used provided it achieves the pre-classification performance described in clause 4.4.3.13.2.4. of this Chapter .

4.4.3.13.2.2. The sample probe shall be installed near the tunnel centre line between 10 and 20 tunnel diameters downstream of the exhaust gas inlet to the tunnel and have an internal diameter of at least 12 mm.

If more than one simultaneous sample is drawn from a single sample probe, the flow drawn from that probe shall be split into identical sub-flows to avoid sampling artefacts.

If multiple probes are used, each probe shall be sharp-edged, open-ended and facing directly into the direction of flow. Probes shall be equally spaced at least 5 cm apart around the central longitudinal axis of the dilution tunnel.

- 4.4.3.13.2.3. The distance from the sampling tip to the filter mount shall be at least 5 probe diameters, but shall not exceed 1020 mm.
- 4.4.3.13.2.4. The pre-classifier (e.g. cyclone, impactor etc.) shall be located upstream of the filter holder assembly. The pre-classifier 50 percent cut point particle diameter shall be between 2.5  $\mu\text{m}$  and 10  $\mu\text{m}$  at the volumetric flow rate selected for sampling particulate mass emissions. The pre-classifier shall allow at least 99 percent of the mass concentration of 1  $\mu\text{m}$  particles entering the pre-classifier to pass through the exit of the pre-classifier at the volumetric flow rate selected for sampling particulate mass emissions. However, a sampling probe, used as an appropriate size-classification device, such as that shown in Figure 6 of this Chapter, is acceptable as an alternative to a separate pre-classifier.
- 4.4.3.13.3. Sample and flow meter
- The sample gas flow measurement unit shall consist of pumps, gas flow regulators and flow measuring units.
- 4.4.3.13.4. The hydrocarbon sampling system consists of a heated sampling probe, line, filter and pump. The sampling probe shall be installed in such a way, at the same distance from the exhaust gas inlet as the particulate sampling probe that neither interferes with samples taken by the other. It shall have a minimum internal diameter of 4 mm.
- 4.4.3.13.5. All heated parts shall be maintained at a temperature of 463K (190°C)  $\pm$  10K by heating system.
- 4.4.3.13.6. If it is not possible to compensate for variations in the flow rate, there shall be a heat exchanger and a temperature control device shall be used, so as to ensure that the flow rate in the system is constant and the sampling rate is accordingly proportional.
- 4.4.3.13.7. The temperature of the gas flow in the flow meter may not fluctuate by more than  $\pm$  3°C, except during regeneration tests on vehicles equipped with periodically regenerating after-treatment devices. In addition, the sample mass flow rate shall remain proportional to the total flow of diluted exhaust gas to within a tolerance of  $\pm$  5% of the particulate sample mass flow rate. Should the volume of flow change unacceptably as a result of excessive filter loading, the test shall be stopped. When the test is repeated, the rate of flow shall be decreased.
- 4.4.3.13.8. Filter and filter holder
- 4.4.3.13.8.1. A valve shall be located downstream of the filter in the direction of flow. The valve shall be responsive enough to open and close within one second of the start and end of the test.
- 4.4.3.13.8.2. It is recommended that the mass collected on the 47 mm diameter filter ( $P_e$ ) is  $\geq$  20  $\mu\text{g}$  and that the filter loading is maximized in line with the requirements of clause 4.4.3.12.6, 4.4.3.12.7 and 4.4.3.13.8 of this Chapter.



- 4.4.3.13.8.3 For a given test, the gas filter face velocity shall be set to a single value within the range 20 cm/s to 80 cm/s, unless the dilution system is being operated with sampling flow proportional to CVS flow rate.
- 4.4.3.13.8.4 Fluorocarbon coated glass fibre filters or fluorocarbon membrane filters are required. All filter types shall have a 0.3 µm DOP (dioctylphthalate) or PAO (poly-alpha-olefin) CS 68649-12-7 or CS 68037- 01-4 collection efficiency of at least 99 percent at a gas filter face velocity of 5.33 cm/s.
- 4.4.3.13.8.5 The filter holder assembly shall be of a design that provides an even flow distribution across the filter stain area. The filter stain area shall be at least 1075 mm<sup>2</sup>.
- 4.4.3.13.9 Filter weighing chamber and balance
- 4.4.3.13.9.1 The microgram balance used to determine the weight of a filter shall have a precision standard deviation of 2 µg and resolution of 1 µg or better.

It is recommended that the microbalance be checked at the start of each weighing session by weighing one reference weight of 50 mg. This weight shall be weighed three times and the average result recorded. The weighing session and balance are considered valid if the average result of the weighing is within ± 5 µg of the result from the previous weighing session.

The weighing chamber (or room) shall meet the following conditions during all filter conditioning and weighing operations:

- Temperature maintained at  $295.2 \pm 3$  K ( $22 \pm 3^\circ\text{C}$ );
- Relative humidity maintained at  $45 \pm 8$  percent;
- Dew point maintained at  $282.7 \pm 3$  K ( $9.5 \pm 3^\circ\text{C}$ ).

It is recommended that temperature and humidity conditions be recorded along with sample and reference filter weights.

- 4.4.3.13.9.2 Buoyancy correction

All filter weights shall be corrected for filter buoyancy in air.

The buoyancy correction depends on the density of the sample filter medium, the density of air, and the density of the calibration weight used to calibrate the balance. The density of the air is dependent on the pressure, temperature and humidity. It is recommended that the temperature and dew point of the weighing environment be controlled to  $295.2\text{K} \pm 1\text{K}$  ( $22 \pm 1^\circ\text{C}$ ) and  $282.7\text{K} \pm 1\text{K}$  ( $9.5 \pm 1^\circ\text{C}$ ) respectively.

However, the minimum requirements stated in clause 4.4.3.13.9.1. of this Chapter will also result in an acceptable correction for buoyancy effects. The correction for buoyancy shall be applied as follows:

Equation 1

$$m_{corr} = \frac{m_{uncorr} \left( 1 - \left( \frac{\rho_{air}}{\rho_{weight}} \right) \right)}{\left( 1 - \left( \frac{\rho_{air}}{\rho_{media}} \right) \right)}$$

$m_{corr}$  = PM mass corrected for buoyancy

$m_{uncorr}$  = PM mass uncorrected for buoyancy

$\rho_{air}$  = density of air in balance environment

$\rho_{weight}$  = density of calibration weight used to span balance

$\rho_{media}$  = density of PM sample medium (filter) with filter medium  
 Teflon coated glass fibre (e.g.TX40): $\rho_{media}=2.300\text{kg/m}^3$   
 $\rho_{air}$  can be calculated as follows:

Equation 2

$$\rho_{air} = \frac{P_{abs} * M_{mix}}{R * T_{amb}}$$

where:

$P_{abs}$  = absolute pressure in balance environment

$M_{mix}$  = molar mass of air in balance environment (28.836 gmol<sup>-1</sup>)

$R$  = molar gas constant (8.314 Jmol<sup>-1</sup>K<sup>-1</sup>)

$T_{amb}$  = absolute ambient temperature of balance environment

The chamber (or room) environment shall be free of any ambient contaminants (such as dust) that would settle on the particulate filters during their stabilization.

Limited deviations from weighing room temperature and humidity specifications shall be allowed provided their total duration does not exceed 30 minutes in any one filter conditioning period. The weighing room shall meet the required specifications prior to personal entrance into the weighing room. No deviations from the specified conditions are permitted during the weighing operation.

The effects of static electricity shall be nullified. This may be achieved by grounding the balance through placement on an antistatic mat and neutralization of the particulate filters prior to weighing using a Polonium neutralizer or a device of similar effect. Alternatively, nullification of static effects may be achieved through equalization of the static charge.

4.4.3.13.9.3 A test filter shall be removed from the chamber no earlier than an hour before the test begins.

4.4.3.14. Recommended system description Figure 3 of this chapter is a schematic drawing of the recommended particulate sampling system. Since various configurations can produce equivalent results, exact conformity with this figure is not required. Additional components such as instruments, valves, solenoids, pumps and switches may be used to provide additional information and coordinate the functions of component systems. Further components that are not needed to maintain accuracy with other system configurations may be excluded if their exclusion is based on good engineering judgment.

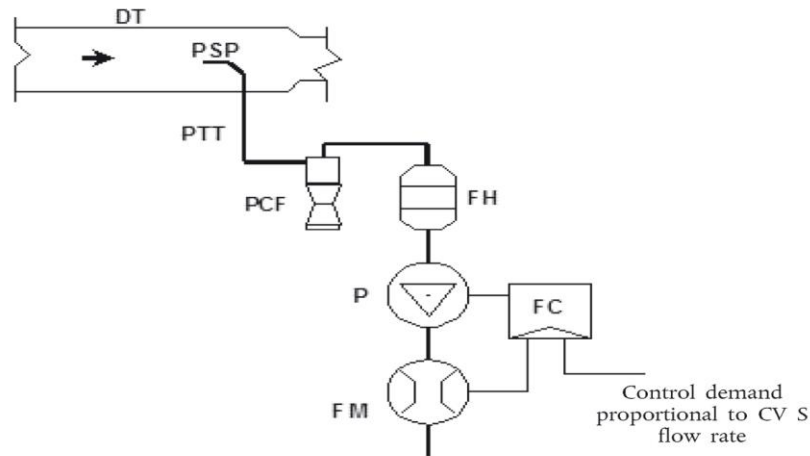

**Figure 3**  
**Recommended particulate sampling system**

A sample of the diluted exhaust gas is taken from the full flow dilution tunnel (DT) through the particulate sampling probe (PSP) and the particulate transfer tube (PTT) by means of the pump (P). The sample is passed through the particle size pre-classifier (PCF) and the filter holders (FH) that contain the particulate sampling filters. The flow rate for sampling is set by the flow controller (FC).

#### 4.4.4. Driving schedules

##### 4.4.4.1. Test cycles

Test cycle for the type I test is described in Appendix 6 of this chapter.

General Conditions under which the cycle is carried out: preliminary testing cycles should be carried out if necessary to determine how best to actuate the accelerator and brake controls so as to achieve a cycle approximately to the theoretical cycle within the prescribed limits

##### 4.4.4.2. Vehicle speed and time tolerances

4.4.4.2.1. A tolerance of  $\pm 1$  km/h shall be allowed between the indicated speed and the theoretical speed during acceleration, during steady speed and during deceleration, when the vehicle's brakes are used. If the vehicle decelerates more rapidly without the use of the brakes, then the timing of the theoretical cycle shall be restored by constant speed or idling period merging into the following operation. Speed tolerances greater than those prescribed shall be accepted, during phase changes provided that the tolerances are never exceeded for more than 0.5 second on any one occasion.

4.4.4.2.2. Time tolerances of  $\pm 0.5$  second shall be allowed. The above tolerances shall apply equally at the beginning and at the end of each gear changing period. The speed and time tolerances shall be combined as indicated in Figure 4 of this chapter.

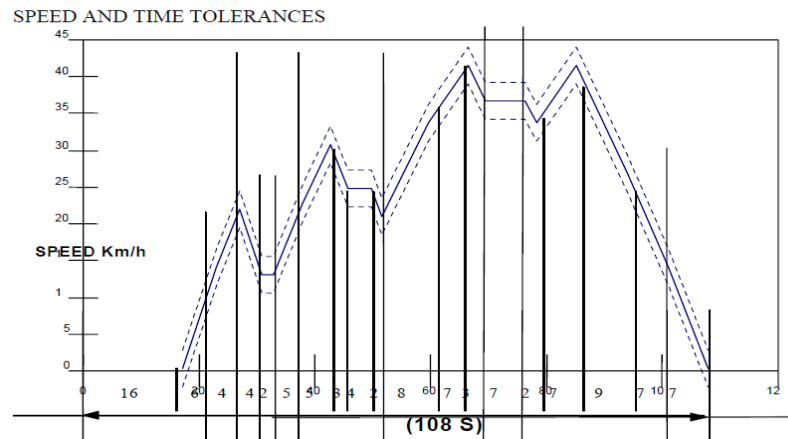

**Figure 4**  
**Operating cycle with speed and time tolerances**

#### 4.4.4.2.3 Use of the gear box:

The use of the gearbox in case of testing on chassis dynamometer shall be in accordance with Clause 4.4.4.2.3.1 of this Chapter

4.4.4.2.3.1 Vehicles which do not attain the acceleration and maximum speed values required in the operating cycle shall be operated with the accelerator control fully depressed until they once again reach the required operating curve. Deviations from the operating cycle shall be recorded in the test report. The use of the gear box shall be as specified by the manufacturer. However, in the absence of such instructions, the following points shall be taken into account:

##### 4.4.4.2.3.1.1 Manual Change Gear Box:

4.4.4.2.3.1.1.1. During each phase at constant speed, the rotating speed of the engine shall be, if possible, between 50 percent and 90 percent of the speed corresponding to the maximum power of the engine. When this speed can be reached in two or more gears, the vehicle shall be tested with the higher gear engaged.

4.4.4.2.3.1.1.2. During acceleration, the vehicle shall be tested in whichever gear is appropriate to the acceleration imposed by the cycle. A higher gear shall be engaged at the latest when the rotating speed is equal to 110percent of the speed corresponding to the maximum power of the engine.

4.4.4.2.3.1.1.3 During deceleration, a lower gear shall be engaged before the engine starts to idle roughly, at the latest when the engine revolutions are equal to 30 percent of the speed corresponding to the maximum power of the engine. No change down to first gear shall be effected during deceleration.

4.4.4.2.3.1.1.4 Vehicles equipped with an overdrive arrangement if fitted, which the driver can actuate shall be tested with the overdrive out of action.

4.4.4.2.3.1.1.5. When it is not possible to adhere to the cycle, the operating cycle will be modified for gear change points, allowing 2 seconds time interval at constant speed for each gear change keeping the total time constant. Figure 1 of Appendix 6 of this Chapter shows the operating cycle with recommended gear positions.

4.4.4.2.3.1.2 Automatic gear box:

Vehicles equipped with automatic shift gear boxes shall be tested with the highest gear (drive) engaged. The accelerator shall be used in such a way as to obtain the steadiest acceleration possible, enabling the various gears to be engaged in the normal order.

**4.4.5. Dynamometer settings**

A full description of the chassis dynamometer and instruments shall be provided in accordance with Appendix 3 of this chapter. Measurements shall be taken to the accuracies specified in clause 4.4.6 of this chapter. The running resistance force for the chassis dynamometer settings can be derived either from on-road coast-down measurements or from a running resistance table, with reference to Appendix 5 and 7 of this chapter.

4.4.5.1. Chassis dynamometer setting derived from on-road coast-down measurements

To use this alternative, on-road coast-down measurements shall be carried out as specified in Appendix 7 of this chapter.

4.4.5.1.1 Requirements for the equipment

The instrumentation for the speed and time measurement shall have the accuracies specified in clause 4.4.6 of this chapter.

4.4.5.1.2 Inertia mass setting

4.4.5.1.2.1. The equivalent inertia mass  $m_i$  for the chassis dynamometer shall be the flywheel equivalent inertia mass,  $m_{fi}$ , closest to the sum of the kerb mass of the vehicle and uniform increase of 150 kg. Alternatively, the equivalent inertia mass  $m_i$  can be derived from Appendix 5 of this Chapter.

4.4.5.1.2.2. If the reference mass  $m_{ref}$  cannot be equalized to the flywheel equivalent inertia mass  $m_i$ , to make the target running resistance force  $F^*$  equal to the running resistance force  $F_E$  (which is to be set to the chassis dynamometer), the corrected coast-down time  $\Delta T_E$  may be adjusted in accordance with the total mass ratio of the target coast-down time  $\Delta T_{road}$  in the following sequence:

Equation 3

$$\Delta T_{road} = \frac{1}{3.6} (m_a + m_{r1}) \frac{2\Delta v}{F^*}$$

Equation 4

$$\Delta T_E = \frac{1}{3.6} (m_i + m_{r1}) \frac{2\Delta v}{F_E}$$

Equation 5

$$F_E = F^*$$

Equation 6

$$\Delta T_E = \Delta T_{road} * \frac{m_i + m_{r1}}{m_a + m_{r1}}$$

with

$$0.95 < \frac{m_i + m_{r1}}{m_a + m_{r1}} < 1.05$$

where

$m_{r1}$  may be measured or calculated, in kilograms, as appropriate. As an alternative,  $m_{r1}$  may be estimated as 4% of  $m$ .

4.4.5.2. Running resistance force derived from a running resistance table

4.4.5.2.1. The chassis dynamometer may be set by the use of the running resistance table instead of the running resistance force obtained by the coast-down method. In this table method, the chassis dynamometer shall be set by the reference mass regardless of particular vehicle characteristics.

**Note:** Care shall be taken when applying this method to vehicles with extraordinary characteristics

4.4.5.2.2. The flywheel equivalent inertia mass  $m_{fi}$  shall be the equivalent inertia mass  $m_i$  specified in Appendix 5 and 7 of this chapter where applicable. The chassis dynamometer shall be set by the rolling resistance of the non-driven wheels:

- (a) and the aero drag coefficient
- (b) specified in Appendix 5 of this chapter or determined in accordance with the procedures set out in Appendix 7 of this chapter respectively.

4.4.5.2.3. The running resistance force on the chassis dynamometer  $F_E$  shall be determined using the following equation:

Equation 7:

$$F_E = F_T = a + b * V^2$$

4.4.5.2.4. The target running resistance force  $F^*$  shall be equal to the running resistance force obtained from the running resistance table  $F_T$ , because the correction for the standard ambient conditions is not necessary.

4.4.6. **Measurement accuracies**

Measurements shall be taken using equipment that fulfills the accuracy requirements in Table 1 of this Chapter:

Measurement items	At measured value	Resolution
(a) Running resistance force, F	+ 2 percent	—
(b) Vehicle speed (v1, v2)	± 1 percent	0.2 km/h
(c) Coast-down speed interval ( $2\Delta v = v1 - v2$ )	± 1 percent	0.1 km/h
(d) Coast-down time ( $\Delta t$ )	± 0.5 percent	0.01 s
(e) Total vehicle mass ( $m_{ref}$ )	± 0.5 percent	1.0 kg
(f) Wind speed	± 10 percent	0.1 m/s
(g) Wind direction	—	5 deg.
(h) Temperatures	± 1 K	1 K
(i) Barometric pressure	—	0.2 kPa
(j) Distance	± 0.1 percent	1 m
(k) Time	± 0.1 s	0.1 s

## 5.0 TEST PROCEDURES

### 5.1. Description of the Type I Test

The test vehicle shall be subjected to test type I requirements as specified in the following sub-clauses.

5.1.1 Type I test (verifying the average emission of gaseous pollutants, CO<sub>2</sub> emissions and fuel consumption in a characteristic driving cycle)

5.1.1.1. The test shall be carried out by the method described in clause 5.2 of this chapter. The gases shall be collected and analyzed by the prescribed methods. During the test the exhaust gases shall be diluted with air and a proportional sample collected in one or more bags. The contents of the bags will be analyzed at the end of the test.

The total volume of the diluted exhaust shall be measured. Carbon monoxide (CO), hydrocarbon (HC) and nitrogen oxide emissions (NO<sub>x</sub>), and in addition particulate matter (PM) in the case of vehicles equipped with compression ignition engines shall be recorded. Carbon dioxide (CO<sub>2</sub>) shall also be recorded for the purpose of calculation of fuel consumption.

5.1.1.2. Number of tests

5.1.1.2.1. A test lasting a total of 648 seconds and comprising of 6 cycles as described in Appendix 6 of this Chapter shall be carried out, without interruption, with a modification that the exhaust gas sampling should start at initiation (T=0) as per test cycle mentioned in Appendix 6. Vehicles that are fueled with LPG or NG/biomethane, flex fuel H<sub>2</sub>NG or hydrogen shall be tested for the type I test as per procedure set out in Appendix 8 of this chapter.

5.1.1.2.2. The number of tests shall be determined as shown in Figure 5 of this chapter.  $R_{i1}$  to  $R_{i3}$  describe the final measurement results for the first (No 1) test to the third (No 3) test. Nevertheless, for each of the pollutants one of the three results obtained may exceed by not more than 10percent of the applicable limits prescribed for the vehicle concerned, provided the arithmetical mean of the three results is not exceeding the prescribed limit. Where the prescribed limits are exceeded for more than one pollutant, it shall be immaterial whether this occurs in the same test or in different tests. Refer Figure 5 of this chapter flow chart for the number of Type I

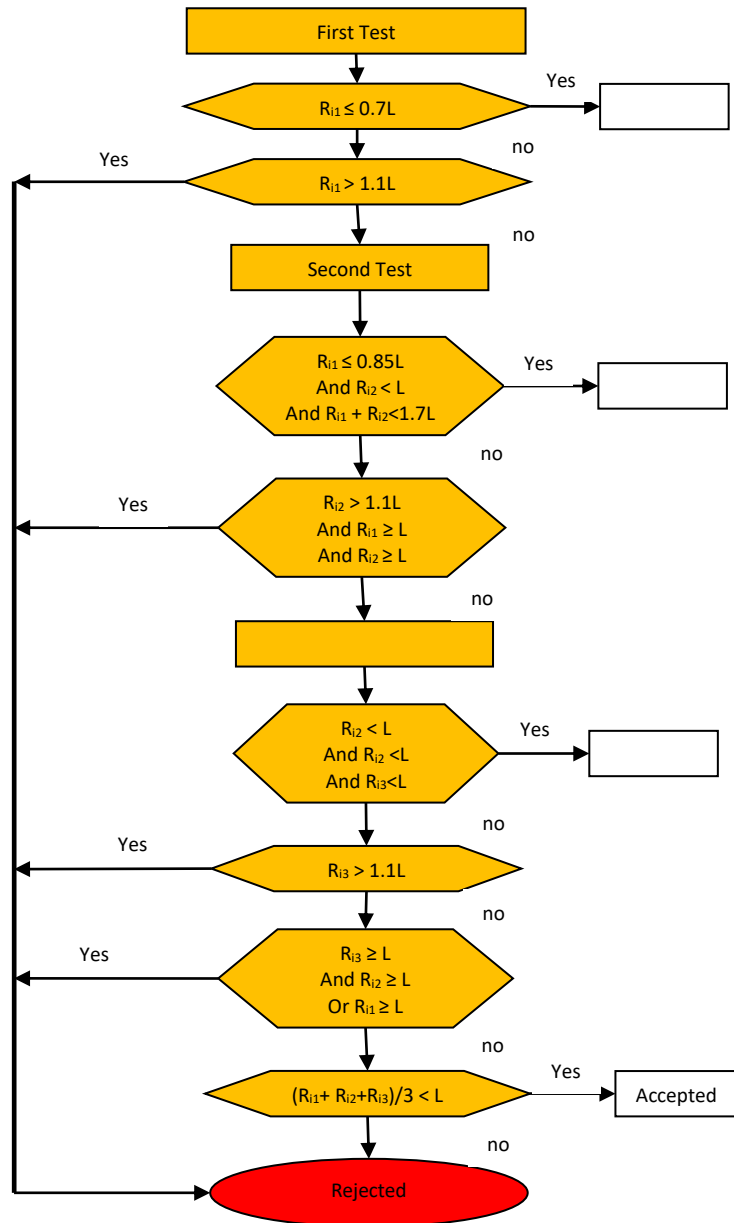

**Figure 5**  
**Flow chart for the number of Type I test**



- 5.1.1.2.3. The number of tests prescribed in Clause 5.1.1.2.2 of this chapter above shall be reduced in the conditions hereinafter defined, where  $R_{i1}$  is the result of the first test and  $R_{i2}$  is the result of the second test for each of the pollutants referred to in Clause 5.1.1.1 above.
- 5.1.1.2.3.1. Only one test shall be performed if the result obtained for each pollutant is less than or equal to 0.7 L i.e.  $R_{i1} \leq 0.70$  L.
- 5.1.1.2.3.2. If the requirements of 5.1.1.2.3.1 is not satisfied, only two tests are performed if for each pollutant in case of the limit is so specified, the following requirements are met.  
 $R_{i1} \leq 0.85$  L and  $R_{i1} + R_{i2} < 1.70$  L and  $R_{i2} < L$ .  
 Subject to the provisions of the clause 5.1.1.2.2 & 5.1.1.2.3, of this Chapter the test shall be repeated three times, the test results shall be multiplied by appropriate deterioration factors as notified in CMVR/notification.  
 $(R_{i1} + R_{i2} + R_{i3})/3 < L$ .  
 The resulting masses of gaseous emission and, in the case of vehicles equipped with compression-ignition engines, the mass of particulates obtained in each test shall not exceed the applicable limits.
- 5.1.1.2.4. Manufacturers shall ensure that type-approval requirements for verifying durability requirements for CO, NO<sub>x</sub>, HC+NO<sub>x</sub> and if applicable, PM are met. At the choice of the manufacturer, one of the following durability test procedures shall be used to provide evidence to the test agency that the environmental performance of a type-approved parent vehicle is durable. The final results shall be rounded off to nearest (mg) as per IS 2 as amended from time to time.
- 5.1.1.2.4.1. Fixed DF (Mathematical Durability Procedure) :  
 For each emission constituent, the product of the deterioration factor set out in notification and the environmental test result of Type I test shall be lower than the emission limits set out in notification.
- 5.1.1.2.4.2. Actual Durability Test with Full Mileage Accumulation:  
 The test vehicles shall physically accumulate the full distance set out in notification and shall be tested in accordance with the procedure laid down in test type V. The emission test results up to and including the full distance shall be lower than the emission limits set out in notification.
- 5.1.1.2.4.3. Actual Durability Test with Partial Mileage Accumulation:  
 The test vehicles shall physically accumulate a minimum of 50 percent of the full distance set out in notification and shall be tested in accordance with the procedure laid down in test type V. As specified in the procedure, the test results shall be extrapolated up to the full distance set out in notification.  
 Both the test results and the extrapolated results shall be lower than the emission limits set out in notification.

- 5.1.1.2.4.4 DF requirements for Type Approval of New Variant/Vehicle of same family of Type V test:  
The test shall be carried out on a run-in vehicle. At the choice of the manufacturer, one of the following durability test procedures shall be used to provide evidence to the test agency that the environmental performance of a type-approved family vehicle is durable.
- 5.1.1.2.4.4.1 Fixed DF (Mathematical Durability Procedure):  
For each emission constituent, the product of the deterioration factor set out in notification and the environmental test result of Type I test shall be lower than the emission limits set out in notification.
- 5.1.1.2.4.4.2 Actual Durability Test with Full Mileage Accumulation done for parent vehicle:  
In case the manufacturer has followed durability test procedure as per Clause 5.1.1.2.4.3 of this chapter for parent vehicle, then:
- a) The exhaust emission values with applying multiplicative or additive DF value calculated as per Clause 3.2.4.6 of Chapter 5 and the environmental test result of Type I test shall be lower than the emission limits set out in notification; or
  - b) If fully aged Golden component shall be used, then environmental test result of Type I test shall be lower than the emission limits set out in notification. Deterioration factor to be calculated as per Clause 3.2.4.6 of Chapter 5
- 5.1.1.2.4.4.3 Actual Durability Test with Partial Mileage Accumulation done for parent vehicle:  
In case the manufacturer has followed durability test procedure as per Clause 5.1.1.2.4.3 of this chapter for parent vehicle, then:
- a) The exhaust emission values with applying multiplicative or additive DF value calculated Clause as per 3.2.4.7 of Chapter 5 and the result of Type I test shall be lower than the emission limits set out in notification; or
  - b) If partially aged Golden component shall be used, then the exhaust emission values with applying multiplicative or additive DF for remaining portion of durability distance shall be calculated as per Clause 3.2.4.8 of Chapter 5 and environmental test result of Type I test shall be lower than the emission limits set out in notification.
  - c) Using the Emission results of Parent vehicle and the emission result of test vehicle (fitted with partial aged golden pollution control devices) at partial mileage, the test results shall be extrapolated up to the full distance set out in the notification. Both the test results and the extrapolated results shall be lower than the emission limits set out in the notification.
- 5.1.1.2.4.5 DF requirements for COP test shall be as follows:  
DF for COP of a variant/parent model shall be the DF being used for type approval of the variant/parent model. If the type approval test has been done by actual mileage accumulation, then applicable

DF referred in 5.1.1.2.4.4.2 (a) and 5.1.1.2.4.4.3 (a), (b) of this Chapter shall be used.

For 5.1.1.2.4.4.2 (b) of this Chapter, DF for COP shall be the DF calculated as per clause 3.2.4.6 of Chapter-5,

For 5.1.1.2.4.4.3 (c) of this Chapter DF for COP shall be the DF calculated as per clause 3.2.4.7 of Chapter-5 using Parent vehicle results.

For each emission constituent, the product of the deterioration factor and the environmental test result of Type I test shall be lower than the emission limits set out in notification.

5.1.1.2.4.6 At the choice of the manufacturer one of the following durability test procedures as described in below table shall be used for type approval:

The emission test results multiplied by applicable D.F shall be lower than emission limits set out in notification.

If the actual mileage accumulation (full) has been carried out, none of the emission values shall exceed these limits.

<b>Table No 2</b>					
<b>Option No.</b>	<b>Option</b>		<b>D.F to be applied</b>		<b>Relative Clause</b>
	<b>Condition of Vehicle for Type-I test.</b>	<b>Condition of Pollution control devices.</b>	<b>Applicable D.F. for Type Approval</b>	<b>D.F. Calculation</b>	
1	New vehicle, run-in	Degreened by Running-In	Fixed D.F	As per the Notification	5.1.1.2.4.1, 5.1.1.2.4.4.1
2 <sup>(1)</sup>	Aged	Full mileage accumulation done as per Chapter-5	No D.F to be applied	3.2.4.6 of Chapter-5 [Only calculation]	5.1.1.2.4.2
3 <sup>(1)</sup>	Partially aged	Partial mileage accumulation done as per Chapter 5	No D.F to be applied	i. 3.2.4.7 and ii. 3.2.4.8 of Chapter 5 [Only calculation]	5.1.1.2.4.3
4	New vehicle, run-in	Degreened by Running-In	D.F. calculated in Option No. 2 of table	--	5.1.1.2.4.4.2 (a)
			D.F. calculated in Option No. 3 i. of table	--	5.1.1.2.4.4.3 (a)
5	New vehicle, run-in	Using fully aged golden pollution control devices	No D.F to be applied		5.1.1.2.4.4.2 (b)
6	New Vehicle, run-in	Using partially aged golden pollution control devices	D.F. calculated in Option No. 3 i. of table	--	5.1.1.2.4.4.3 (b)
			No D.F to be applied	--	5.1.1.2.4.4.3 (c)
<sup>(1)</sup> Test vehicle is the parent vehicle for options 4, 5 and 6.					

## 5.2. Type I tests

### 5.2.1. Overview

5.2.1.1. The Type I test consists of prescribed sequences of dynamometer preparation, fueling, parking, and driving cycle as described in Appendix 6 of this Chapter.

5.2.1.2. The test is designed to determine combined hydrocarbon, + carbon monoxide, oxides of nitrogen, carbon dioxide, particulate matter mass emissions if applicable and fuel/energy consumption while simulating real-world operation. The test consists of engine start-ups and L5-category vehicle operation on a chassis dynamometer, through a specified driving cycle. A proportional part of the diluted exhaust emissions is collected continuously for subsequent analysis, using a constant volume (variable dilution) sampler (CVS).

5.2.1.3. Except in cases of component malfunction or failure, all emission-control systems installed on or incorporated in a tested vehicle shall be functioning during all procedures.

5.2.1.4. Background concentrations are measured for all emission constituents for which emissions measurements are taken. For exhaust testing, this requires sampling and analysis of the dilution air.

5.2.1.5. Background particulate mass measurement:

The particulate background level of the dilution air may be determined by passing filtered dilution air through the particulate filter. This shall be drawn from the same point as the particulate matter sample, if a particulate mass measurement is applicable. One measurement may be performed prior to or after the test. Particulate mass measurements may be corrected by subtracting the background contribution from the dilution system. The permissible background contribution shall be  $\leq 1$  mg/km (or equivalent mass on the filter). If the background contribution exceeds this level, the default figure of 1 mg/km (or equivalent mass on the filter) shall be used. Where subtraction of the background contribution gives a negative result, the particulate mass result shall be considered to be zero.

### 5.2.2. Dynamometer load and inertia setting:

Dynamometer with fixed load curve: the load simulator shall be adjusted to absorb the power exerted on the driving wheels at a steady speed of 80 km/h and the absorbed power at 50 km/h shall be noted. The means by which this load is determined.

5.2.2.1. Dynamometer with adjustable load curve: the load simulator shall be adjusted in order to absorb the power exerted on the driving wheels at various steady speeds of 50, 40, 30 and 20 km/h.

5.2.2.2. The means by which these loads are determined and set are described in Appendix 7 of this Chapter.

- 5.2.2.2.1. Load and inertia setting load determined with vehicle road test
- The dynamometer shall be adjusted so that the total inertia of the rotating masses will simulate the inertia and other road load forces acting on the vehicle when driving on the road. The means by which this load is determined is described in clause 4. Load and Inertia adjustment to be carried out with vehicle mounting on the chassis dynamometer with proper vehicle warm up as per manufacturer recommendation before vehicle preconditioning cycle. Derived load set values to be used for vehicle preconditioning and for mass emission test.
- At the end of the test, road load verification to be carried out with vehicle and shall lie within  $\pm 5$  percent.
- 5.2.2.3. Chassis Dynamometers with electrical inertia simulation shall be demonstrated to be equivalent to mechanical inertia systems. The means by which equivalence is established is described in Appendix 3 of this Chapter.
- 5.2.2.4 **Chassis Dynamometer Calibration**
- The chassis dynamometer system shall comply with the calibration and verification methods laid down in Appendix 3 of this chapter.
- 5.2.2.4.1. The dynamometer should be calibrated periodically as recommended by the manufacturer of the chassis dynamometer and then calibrated as required. The calibration shall consist of the manufacturers' recommended procedure and a determination of the dynamometer frictional power absorption at 40 km/h when being used for testing of L5 Category vehicles. One method for determining this is given in Appendix 3 of this chapter. Other methods may be used if they are proven to yield equivalent results.
- 5.2.2.4.2. The performance check consists of conducting dynamometer coast down time at one or more inertia power setting and comparing the coast down time to that recorded during the last calibration. If the coast down time differs by more than 1 second, a new calibration is required.
- 5.2.3. **Calibration of gas analysis system**
- 5.2.3.1. **Establishment of Calibration Curve**
- 5.2.3.1.1. The analyzer calibration curve shall be established by at least five calibration points, spaced as uniformly as possible. The nominal concentration of the calibration gas of the highest concentration shall be at least equal to 80percent of the full scale.
- 5.2.3.1.2. The calibration curve is calculated by the least square method. If the degree of the polynomial resulting from the curve is greater than 3, the number of calibration points shall be at least equal to this polynomial degree plus 2.
- 5.2.3.1.3. The calibration curve shall not differ by more than 2percent from the nominal value of calibration gas of each calibration point.

- 5.2.3.1.4. The different characteristic parameters of the analyzer, particularly, the scale, the sensitivity, the zero point and the date of carrying out the calibration should be indicated on the calibration curve.
- 5.2.3.1.5. It can be shown to the satisfaction of the test agency, that alternative technology e.g. computer, electronically controlled range switch etc., can give equivalent accuracy, then these alternatives may be used.
- 5.2.3.2 **Verification of calibration**
  - 5.2.3.2.1. The calibration procedure shall be carried out as often as necessary and in any case within one month preceding the type approval emission test and once in six months for verifying conformity of production.
  - 5.2.3.2.2. The verification should be carried out using standard gases. The same gas flow rates shall be used as when sampling exhaust.
  - 5.2.3.2.3. A minimum of two hours shall be allowed for warming up the analyzers.
  - 5.2.3.2.4. The NDIR analyzer shall be tuned, where appropriate, and the flame combustion of the FID analyzer optimized.
  - 5.2.3.2.5. Using purified dry air (or nitrogen), the CO and NO<sub>x</sub> analyzers' shall be set at zero; dry air shall be purified for the HC analyzer. Using appropriate calibrating gases mentioned in 5.2.5.3 of this Chapter, the analyzers shall be reset.
  - 5.2.3.2.6. The zero setting shall be rechecked and the procedure described in Clause 5.2.3.2.4 and 5.2.3.2.5 above repeated, if necessary.
  - 5.2.3.2.7. The calibration curves of the analyzers should be verified by checking at least at five calibration points, spaced as uniformly as possible. The nominal concentration of the calibration gas of the highest concentration shall be at least equal to 80percent of the full scale. It should meet the requirement of clause 5.2.3.1.3 above.
  - 5.2.3.2.8. If it does not meet, the system should be checked, fault, if any, corrected and a new calibration curve should be obtained.
- 5.2.3.3. **Pre & Post-test Checks**
  - 5.2.3.3.1. Pre- test Checks
    - 5.2.3.3.1.1. A minimum of two hours shall be allowed for warming up the infra-red NDIR analyzer, but it is preferable that power be left on continuously in the analyzers. The chopper motors may be turned off when not in use.
    - 5.2.3.3.1.2. Each normally used operating range shall be checked prior to each analysis.
    - 5.2.3.3.1.3. Using purified dry air (or nitrogen), the CO and NO<sub>x</sub> analyzer's shall be set at zero; dry air shall be purified for the HC analyzer.

- 5.2.3.3.1.4. Span gas having a concentration of the constituent that will give a 75-95 percent full-scale deflection shall be introduced and the gain set to match the calibration curve. The same flow rate shall be used for calibration, span and exhaust sampling to avoid correction for sample cell pressure.
- 5.2.3.3.1.5. The nominal value of the span calibration gas used shall remain within  $\pm 2$  percent of the calibration curve.
- 5.2.3.3.1.6. If it does not, but it remains within  $\pm 5$  percent of the calibration curve, the system parameters such as gain of the amplifier, tuning of NDIR analyzers, optimization of FID analyzers etc. may be adjusted to bring within  $\pm 2$  percent.
- 5.2.3.3.1.7. If the system does not meet the requirement of 5.2.3.3.1.5 and 5.2.3.3.1.6 of this Chapter above, the system should be checked, fault, if any corrected and a new calibration curve should be obtained.
- 5.2.3.3.1.8. Zero shall be checked and the procedures described in clause 5.2.3.3.1.4 of this Chapter above repeated, if required.

#### 5.2.3.3.2. Post-test Checks

After testing, zero gas and the span gas shall be used for re-checking. The analysis is considered acceptable if the difference between two measuring results is less than 2 percent.

#### 5.2.3.4. **Check for fid hydrocarbon response**

##### 5.2.3.4.1. Detector response optimization

The FID shall be adjusted according to the manufacturer's specifications. To optimize the response, propane in air shall be used on the most common operating range.

##### 5.2.3.4.2. Response factors of different hydrocarbons and recommended limits

The response factor ( $R_f$ ) for a particular hydrocarbon species is the ratio of the FID  $C_1$  reading to the gas cylinder concentration, expressed as ppm  $C_1$ .

The concentration of the test gas shall be at a level to give a response of approximately 80 percent of full-scale deflection for the operating range. The concentration shall be known to an accuracy of  $\pm 2$  percent in reference to a gravimetric standard expressed in volume. In addition, the gas cylinder shall be pre-conditioned for 24 hours at a temperature of between 20°C and 30°C.

Response factors shall be determined when introducing an analyzer into service and thereafter at major service intervals. The test gases to be used and the recommended response factors are:

Methane and purified air:  $1.00 < R_f < 1.15$

or  $1.00 < R_f < 1.05$  for NG/biomethane fueled vehicles

Propylene and purified air:  $0.90 < R_f < 1.00$

Toluene and purified air:  $0.90 < R_f < 1.00$

These are relative to a response factor ( $R_f$ ) of 1.00 for propane and purified air.

## 5.2.3.4.3. Oxygen interference check and recommended limits

The response factor shall be determined as described in 5.2.3.4.2. The test gas to be used and recommended response factor range are:

Propane and nitrogen  $0.95 \leq R_f \leq 1.05$ ,

5.2.3.5. **Efficiency test of the NO<sub>x</sub> converter**

5.2.3.5.1 The efficiency of the converter used for the conversion of NO<sub>2</sub> into NO is tested as follows :

5.2.3.5.1.1. Using the test set up shown in Figure 5 of this chapter and the procedure described below, the efficiency of converters can be tested by means of an ozonator.

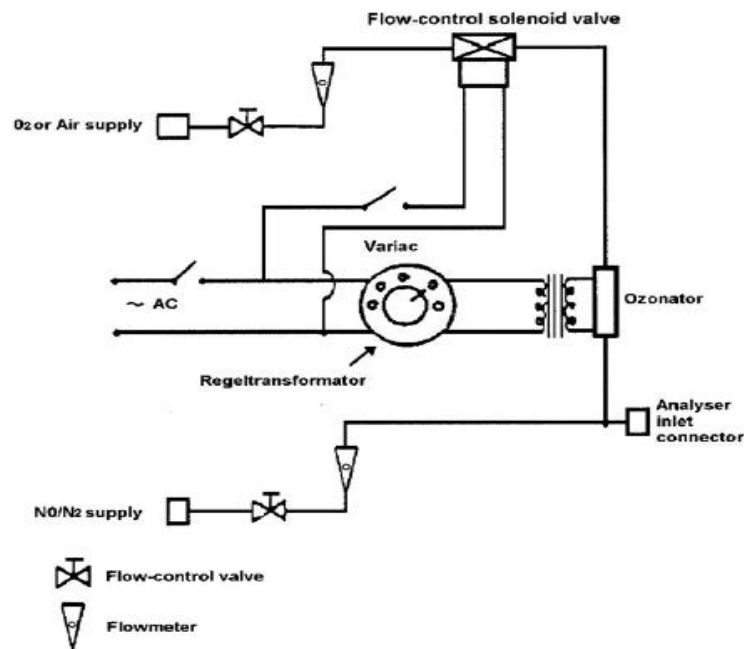

**Figure 6**  
**Schematic of Set-up for checking the efficiency of NO<sub>x</sub> converter**

5.2.3.5.2. Calibrate the CLA analyses in the most common operating range following the manufacturer's specifications using zero and span gas (the NO content of which should amount to about 80 percent of the operating range and the NO<sub>2</sub> concentration of the gas mixture shall be less than 5 percent of the NO concentration). The NO<sub>x</sub> analyzer shall be in the NO mode so that span gas does not pass through the converter. Record the indicated concentration.

5.2.3.5.3. Via a T-fitting, oxygen or synthetic air is added continuously to the gas flow until the concentration indicated is about 10 percent less than the indicated calibration concentration given in Clause 5.2.3.4.2 of this Chapter above. Record the indicated concentration (c). The ozonator is kept deactivated throughout this process.

5.2.3.5.4. The ozonator is now activated to generate enough ozone to bring the NO concentration down to 20 percent (minimum 10 percent) of the calibration concentration given in 5.2.3.5.2. of this Chapter Record the indicated concentration (d).



- 5.2.3.5.5. The NO<sub>x</sub> analyzer is then switched to the NO<sub>x</sub> mode which means that the gas mixture (consisting of NO, NO<sub>2</sub>, O<sub>2</sub> and N<sub>2</sub>) now passes through the converter. Record the indicated concentration (a).
- 5.2.3.5.6. The ozonator is now deactivated. The mixture of gases described in Clause 5.2.3.5.3 of this Chapter above passes through the converter into the detector. Record the indicated concentration (b).
- 5.2.3.5.7. With the ozonator deactivated, the flow of oxygen or synthetic air is also shut off. The NO<sub>x</sub> reading of the analyser shall then be no more than 5 percent above the figure in Clause 5.2.3.5.2 of this Chapter
- 5.2.3.5.8. The efficiency of the NO<sub>x</sub> converter is calculated as follows:

$$\text{Efficiency (\%)} = \left( 1 + \frac{(a - b)}{(c - d)} \right) * 100$$

- 5.2.3.5.9. The efficiency of the converter shall not be less than 95percent.
- 5.2.3.5.10 The efficiency of the converter shall be tested at least once a week.

5.2.3.6. **System leak test :**

A system leakage test shall be performed. The probe shall be disconnected from the exhaust system and the end plugged. The analyser pump shall be switched on. After an initial stabilization period all flow meters and pressure gauges should read zero. If not, the sampling line(s) shall be checked and the fault corrected.

- 5.2.3.7. Calibration and verification procedures of the particulate mass emissions measurement equipment

5.2.3.7.1. Flow meter calibration

The test agency shall check that a calibration certificate has been issued for the flow meter demonstrating compliance with a traceable standard within a 12-month period prior to the test, or since any repair or change which could influence calibration.

5.2.3.7.2. Microbalance calibration

The test agency shall check that a calibration certificate has been issued for the microbalance demonstrating compliance with a traceable standard within a 12-month period prior to the test.

5.2.3.7.3 Reference filter weighing

To determine the specific reference filter weights, at least two unused reference filters shall be weighed within eight hours of, but preferably at the same time as, the sample filter weighing. Reference filters shall be of the same size and material as the sample filter.

If the specific weight of any reference filters changes by more than ± 5 µg between sample filter weighing, the sample filter and reference filters shall be reconditioned in the weighing room and then reweighed.

This shall be based on a comparison of the specific weight of the reference filter and the rolling average of that filter's specific weights.

The rolling average shall be calculated from the specific weights collected in the period since the reference filters were placed in the weighing room. The averaging period shall be between one day and 30 days.

Multiple reconditioning and re-weighing of the sample and reference filters are permitted up to 80 hours after the measurement of gases from the emissions test.

If, within this period, more than half the reference filters meet the  $\pm 5 \mu\text{g}$  criterion, the sample filter weighing can be considered valid.

If, at the end of this period, two reference filters are used and one filter fails to meet the  $\pm 5 \mu\text{g}$  criterion, the sample filter weighing may be considered valid provided that the sum of the absolute differences between specific and rolling averages from the two reference filters is no more than  $10 \mu\text{g}$ .

If fewer than half of the reference filters meet the  $\pm 5 \mu\text{g}$  criterion, the sample filter shall be discarded and the emissions test repeated. All reference filters shall be discarded and replaced within 48 hours.

In all other cases, reference filters shall be replaced at least every 30 days and in such a manner that no sample filter is weighed without comparison with a reference filters that has been in the weighing room for at least one day.

If the weighing room stability criteria outlined in clause 4.4.3.13.9.1 of this Chapter are not met but the reference filter weighing meet the criteria listed in clause 5.2.3.7.3 of this Chapter the vehicle manufacturer has the option of accepting the sample filter weights or voiding the tests, fixing the weighing room control system and re-running the test.

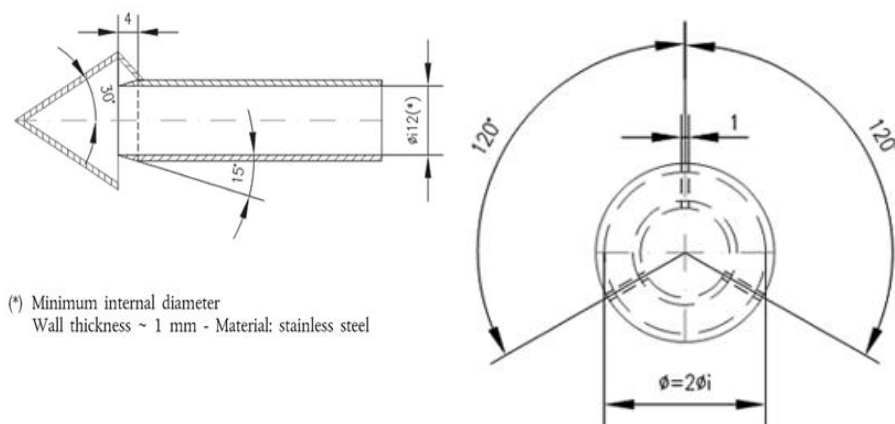

**Figure 7**  
**Particulate sampling probe configuration**

5.2.4. **Analytical equipment**

5.2.4.1. **Pollutant gases shall be analyzed with the following instruments :**

5.2.4.1.1. Carbon monoxide (CO) and carbon dioxide (CO<sub>2</sub>) analysis:

The carbon monoxide and carbon dioxide analysers shall be of the Non-Dispersive Infra-Red (NDIR) absorption type.

5.2.4.1.2. Hydrocarbon (HC) analysis:

Gasoline Vehicles: The hydrocarbons analyser shall be of the Flame ionization (FID) type calibrated with propane gas expressed equivalent to carbon atoms.

5.2.4.1.3. Hydrocarbons (HC) analysis:

Diesel Vehicles: The hydrocarbon analyser shall be of the Flame ionization type Detector with valves, pipe work etc. heated to 190 °C ± 10 °C (HFID). It shall be calibrated with propane gas expressed equivalent to carbon atoms (C<sub>1</sub>).

5.2.4.1.4. Nitrogen oxide (NO<sub>x</sub>) analysis:

The nitrogen oxide analyser shall be of the Chemiluminescent (CLA) type with a NO<sub>x</sub>-NO converter or by NDUVR (non-dispersive ultraviolet resonance absorption) type analyser.

5.2.4.1.5. Particulates:

Gravimetric determination of the particulates collected. These particulates are in each case collected by mounted filters in the sample gas flow. The quantity of particulates collected by each pair of filters shall be as follows:

Equation 8

$$M = \frac{(V_{mix} * m)}{(V_{ep} * d)} \quad \text{or}$$

Equation 9

$$m = \frac{(M * d * V_{ep})}{V_{mix}}$$

Where

V<sub>ep</sub> : Flow through filters.

V<sub>mix</sub> : Flow through tunnel.

M : Particulate mass (g/km)

M<sub>limit</sub> : Limit mass of particulates (limit mass in force, g/km)

m : Mass of particulates collected by filters (g)

d : Actual distance corresponding to the operating cycle (km)

The particulate sample rate (V<sub>ep</sub> / V<sub>mix</sub>) will be adjusted so that for M = M<sub>limit</sub> 1 ≤ m ≤ 5 mg (when 47mm diameter filters are used).

The filter surface consists of a material that is hydrophobic and inert towards the components of exhaust gas (fluorocarbon coated glass fibre filters or equivalent)

## 5.2.4.1.6. Accuracy

The analysers shall have a measuring range compatible with the accuracy required to measure the concentrations of the exhaust gas sample pollutants. Measurements error shall not exceed  $\pm 2$  percent (intrinsic error of analyser) disregarding the true value for the calibration gases. For concentration of less than 100 ppm the measurement error shall not exceed  $\pm 2$  ppm. The ambient air sample shall be measured on the same analyser with an appropriate range. The microgram balance used to determine the weight of all filters shall have an accuracy of 5  $\mu\text{g}$  and readability of 1  $\mu\text{g}$ .

## 5.2.4.1.7. Ice-trap

No gas-drying device shall be used before the analysis unless it is shown that it has no effect on the pollutant content of the gas stream.

5.2.4.2. **Calibration**

5.2.4.2.1. Each analyzer shall be calibrated as often as necessary and in any case in the month before type approval testing and at least once every six months for verifying conformity of production.

5.2.4.2.2. The calibration method that shall be used is described in 5.2.3 of this Chapter for the analyzers indicated in clause 5.2.4.1 of this Chapter above.

5.2.5. **Volume measurement**

5.2.5.1. The method of measuring total dilute exhaust volume incorporated in the constant Volume sampler shall be such that measurement is accurate to within  $\pm 2$  per cent.

5.2.5.2. **Constant volume sampler calibration**

5.2.5.2.1. The Constant Volume Sampler system volume measurement device shall be Calibrated by a suitable method to ensure the prescribed accuracy and at a frequency sufficient to maintain such accuracy.

5.2.5.2.2. An example of a calibration procedure which will give the required accuracy is given in Appendix 4 of this Chapter. The method shall utilize a flow-metering device Which is dynamic and suitable for the high flow rate encountered in Constant Volume Sampler testing. The devices shall be of certified accuracy traceable to an approved national or international standard.

5.2.5.3. **Reference gases**

## 5.2.5.3.1 Pure gases

The following pure gases shall be available, if necessary, for calibration and operation:

Purified nitrogen: (purity:  $\leq 1$  ppm C1,  $\leq 1$  ppm CO,  $\leq 400$  ppm CO<sub>2</sub>,  $\leq 0.1$  ppm NO);

Purified synthetic air: (purity:  $\leq 1$  ppm C1,  $\leq 1$  ppm CO,  $\leq 400$  ppm CO<sub>2</sub>,  $\leq 0.1$  ppm NO); oxygen content between 18 and 21 percent by volume;

Purified oxygen: (purity > 99.5 percent vol. O<sub>2</sub>);

Purified hydrogen (and mixture containing helium): (purity ≤ 1 ppm C1, ≤400 ppm CO<sub>2</sub>); Carbon monoxide: (minimum purity 99.5 percent)

Propane: (minimum purity 99.5 percent.)

5.2.5.3.2 Calibration and span gases

Mixtures of gases with the following chemical compositions shall be available:

C<sub>3</sub>H<sub>8</sub> and purified synthetic air,

CO and purified nitrogen;

CO<sub>2</sub> and purified nitrogen;

NO and purified nitrogen (the amount of NO<sub>2</sub> contained in this calibration gas shall not exceed 5 percent of the NO content).

The true concentration of a calibration gas shall be within ± 2 percent of the stated figure.

5.2.5.3.3. Calibration and verification of the dilution system

The dilution system shall be calibrated and verified and shall comply with the requirements of Appendix 4 of this chapter.

5.2.6 **Emissions tests**

5.2.6.1. **Engine starting and restarting**

5.2.6.1.1. The engine shall be started up by means of the devices provided for this purpose according to the manufacturer's instructions, as incorporated in the owner's manual of production vehicles.

5.2.6.1.1.1 A test lasting a total of 648 seconds and comprising of 6 cycles as described in Appendix 6 of this Chapter shall be carried out, without interruption, with a modification that the exhaust gas sampling should start at initiation (T=0) as per test cycle mentioned in Appendix 6

5.2.6.1.2. If, during the cold start, the test vehicle does not start after 10 seconds of cranking or 10 cycles of the manual starting mechanism, cranking shall cease and the reason for failure to start shall be determined. The revolution counter on the constant volume sampler shall be turned off and the sample solenoid valves placed in the 'standby' position during this diagnostic period. In addition, either the CVS blower shall be turned off or the exhaust tube disconnected from the tailpipe during the diagnostic period.

5.2.6.1.3. If failure to start is caused by vehicle malfunction, corrective action (following the unscheduled maintenance provisions) lasting less than 30 minutes may be taken and the test continued (During the corrective action sampling system shall be deactivated). The sampling system shall be reactivated at the same time cranking is started. The driving schedule timing sequence shall begin when the engine starts. If failure to start is caused by vehicle malfunction and the vehicle cannot be started, the test shall be avoided, the vehicle

removed from the dynamometer, corrective action taken (following the unscheduled maintenance provisions) and the vehicle rescheduled for test from a cold start. The reason for the malfunction (if determined) and the corrective action taken shall be reported.

If failure to start is an operational error, the test vehicle shall be rescheduled for testing from a cold start.

5.2.6.1.4. If the engine ‘false starts’, the operator shall repeat the recommended starting procedure (such as resetting the choke, etc.)

5.2.6.2. **Stalling: Reserved**

5.2.6.3. **Idling**

5.2.6.3.1 Manual-Shift or Semi-Automatic Gear-Box

5.2.6.3.1.1. During periods of idling, the clutch shall be engaged and gears in neutral.

5.2.6.3.1.2. To enable the accelerations to be performed according to normal cycle the vehicle shall be placed in first gear, with clutch disengaged, 5 seconds before the Acceleration following the idling period considered of the driving cycle as per Appendix 6 of this chapter.

5.2.6.3.1.3. The first idling period at the beginning of the cycle shall consist of 11 seconds of idling in neutral with the clutch engaged and 5 seconds in first gear with the clutch disengaged.

5.2.6.3.2. Automatic-shift gear-box: After initial engagement, the selector shall not be operated at any time during the test except in accordance with Clause 5.2.6.4.3 of this Chapter below.

5.2.6.4. **Accelerations**

5.2.6.4.1. Manual Shift Gear Box : Accelerations shall be so performed that the rate of acceleration shall be as constant as possible throughout the phase.

5.2.6.4.2. If acceleration cannot be carried out in the prescribed time, the extra time required is, if possible, deducted from the time allowed for changing gear, but otherwise from the subsequent steady speed period.

5.2.6.4.3. Automatic-shift gear-boxes: If acceleration cannot be carried out in the prescribed time the gear selector shall be operated in accordance with requirements for manual shift gear-boxes.

5.2.6.5. **Decelerations:**

5.2.6.5.1. All decelerations shall be effected by closing the throttle completely. The clutch shall be disengaged, at around a speed of 8 km/hr.

If the period of deceleration is longer than that prescribed for the corresponding phase, the vehicle's brakes shall be used to enable the timing of the cycle to be abided by.

5.2.6.5.2. If the period of deceleration is shorter than that prescribed for the corresponding phase, the timing of theoretical cycle shall be restored by constant speed or idling period merging into the following operation

5.2.6.6. **Steady Speeds:**

5.2.6.6.1. "Pumping" or the closing of the throttle shall be avoided when passing from acceleration to the following steady speed.

5.2.6.6.2. Periods of constant speed shall be achieved by keeping the accelerator position fixed.

5.2.7. **Drive instructions**

5.2.7.1. The test vehicle shall be driven with minimum throttle movement to maintain the desired speed. No simultaneous use of brake and throttle shall be permitted.

5.2.7.2. If the test vehicle cannot accelerate at the specified rate, it shall be operated with the throttle fully opened until the roller speed reaches the value prescribed for that time in the driving schedule

5.2.8. **Dynamometer test runs**

5.2.8.1. The complete dynamometer test consists of test cycle as described in Appendix 6 of this chapter.

5.2.8.2. During the test, the speed can be recorded against time so that the correctness of the cycle performed can be assessed.

**6.0 ANALYSIS OF RESULTS**

6.1. **Type I Test**

6.1.1. **Exhaust emission analysis**

6.1.1.1. **Procedure for Sampling and Analysis :**

6.1.1.1.1 Sampling:

Sampling for all vehicles shall begin at start of the driving cycle ( $T_0$ ) defined in Appendix 6 of this chapter.

6.1.1.1.2. Analysis :

6.1.1.1.2.1. The exhaust gases contained in the bag shall be analyzed as soon as possible and in any event not later than 20 minutes after the end of the test cycles. The spent particulate filters shall be taken to the chamber no later than 1 hour after conclusion of the test on the exhaust gases and shall be conditioned for between 2 and 36 hours and then be weighed.

6.1.1.1.2.2. Prior to each sample analysis the analyser range to be used for each pollutant shall be set to zero with the appropriate zero gas.

6.1.1.1.2.3. The analysers shall then be set to the calibration curves by means of span gases of nominal concentrations of 70 to 100 percent of the range.

- 6.1.1.1.2.4. The analyzers' zeros shall then be re-checked. If the reading differs by more than 2 percent of range from that set in clause 6.1.1.1.2.2 of this Chapter above, the procedure shall be repeated.
- 6.1.1.1.2.5. The samples shall then be analyzed.
- 6.1.1.1.2.6. After the analysis zero and span points shall be re-checked using the same gases. If these re-checks are within 2 percent those in clause 6.1.1.1.2.3 of this Chapter then the analysis shall be considered acceptable.
- 6.1.1.1.2.7. For all the points in this section, the flow rates and pressure of the various gases shall be the same as those used during calibration of the analysers.
- 6.1.1.1.2.8. The figure adopted for the content of the gases in each of the pollutants measured shall be that read off after stabilization of the measuring device. Diesel hydrocarbon mass emissions shall be calculated from the integrated HFID reading corrected for varying flow, if necessary as shown in this part.

**6.1.1.2. Measuring the distance covered.**

The distance (S) actually covered for a test cycle shall be calculated by multiplying the number of revolutions read from the cumulative counter by the circumference of the roller. This distance shall be expressed in km.

**6.1.1.3. Determination of the Quantity of Gaseous Pollutants Emitted**

The results of all emission tests shall be rounded, using the 'rounding-off method' in IS 2: 1960 to the number of decimal places indicated by expressing the applicable standard to three significant figures.

**6.1.1.3.1. The volume considered:**

The volume to be considered shall be corrected to conform to the conditions of 101.3 kPa and (20°C) 293K.

**6.1.1.3.2. Total Mass of Gaseous Pollutants Emitted:**

The mass, M, of each pollutant emitted by the vehicle during the test shall be determined by obtaining the product of the voluminal concentration and the volume of the gas in question, with due regard for the following densities at the above mentioned reference condition.

$$= \frac{9,104 \cdot A + 136}{1524,152 - 0,583 \cdot A} \cdot 10^6 \text{ mg/m}^3 \text{ for H}_2\text{NG (with A = NG/biomethane quantity within the H}_2\text{NG mixture in (volume \%)).}$$



In the case of carbon monoxide (CO)	d = 1.164 kg/m <sup>3</sup>
In the case of hydrocarbons:	
For petrol (E5) (C <sub>1</sub> H <sub>1,89</sub> O <sub>0,016</sub> )	d = 0.588 kg/m <sup>3</sup>
For petrol (E10) (C <sub>1</sub> H <sub>1,93</sub> O <sub>0,033</sub> )	d = 0.601 kg/m <sup>3</sup>
For diesel (B5) (C <sub>1</sub> H <sub>1,86</sub> O <sub>0,005</sub> )	d = 0.580 kg/m <sup>3</sup>
For diesel (B7) (C <sub>1</sub> H <sub>1,86</sub> O <sub>0,007</sub> )	d = 0.581 kg/m <sup>3</sup>
For LPG (C <sub>1</sub> H <sub>2,525</sub> )	d = 0.605 kg/m <sup>3</sup>
For NG/biomethane (C <sub>1</sub> H <sub>4</sub> )	d = 0.665 kg/m <sup>3</sup>
For ethanol (E85) (C <sub>1</sub> H <sub>2,74</sub> O <sub>0,385</sub> )	d = 0.869 kg/m <sup>3</sup>
In the case of Nitrogen Oxides (NO <sub>x</sub> )	d = 1.913 kg/m <sup>3</sup>
In the case of Carbon Dioxide (CO <sub>2</sub> )	d = 1.830 kg/m <sup>3</sup>

The mass ‘m’ of particulate pollutant emissions from the vehicle during the test is defined by weighing the mass of particulates collected by two filters, ‘m1’ by the first filter, ‘m2’ by the second filter.

- if  $0.95 (m1 + m2) \leq m1$ ,  $m = m1$ ,
- if  $0.95 (m1 + m2) > m1$ ,  $m = m1 + m2$ ,
- if  $m2 > m1$ , the test shall be cancelled.

6.1.1.4. **The mass emission of pollutants are calculated by means of the following formula:**

Equation 10

$$M_i = \frac{V_{mix} * Q_i * k_H * C_i * 10^{-6}}{d}$$

Where,

$M_i$  = Mass emission of the pollutant i in g/km

$V_{mix}$  = Volume of the diluted exhaust gas expressed in m<sup>3</sup>/test and corrected to standard conditions (20 °C) 293K and 101.3 kPa

$Q_i$  = Density of the pollutant i in g/m<sup>3</sup> at temperature and pressure (293K and 101.3 kPa)

$K_H$  = Humidity correction factor used for the calculation of the mass emissions of oxides of nitrogen. There is no humidity correction for HC and CO.

$C_i$  = Concentration of the pollutant i in the diluted exhaust gas expressed in ppm and corrected by the amount of the pollutant i contained in the dilution air.

d = distance covered in km

6.1.1.5. **Volume determination**

6.1.1.5.1. Calculation of the volume when a variable dilution device with constant flow control by orifice or venturi is used.

Record continuously the parameters showing the volumetric flow, and calculate the total volume for the duration of the test.

6.1.1.5.2. Calculation of volume when a positive displacement pump is used.

The volume of diluted exhaust gas in systems comprising a positive displacement pump is calculated with the following formula:

Equation 11

$$V = V_o * N$$

where,

V = Volume of diluted exhaust gas expressed in m<sup>3</sup>/test (prior to correction)

V<sub>o</sub> = Volume of gas delivered by the positive displacement pump on testing conditions, in m<sup>3</sup>/rev.

N = Number of revolutions per test.

6.1.1.5.3. Correction of the diluted exhaust gas volume to standard conditions. The diluted exhaust gas volume is corrected by means of the following formula :

Equation 12

$$V_{mix} = V * K_1 * \frac{P_B - P_1}{T_P}$$

In which

$$K_1 = \frac{293K}{101.3kPa} = 2.8924(K * kPa^{-1})$$

Where

P<sub>B</sub> = Barometric pressure in the test room in kPa

P<sub>1</sub> = Vacuum at the inlet to the positive displacement pump in kPa relative to the ambient barometric pressure.

T<sub>P</sub> = Average temperature of the diluted exhaust gas entering the positive displacement pump during the test (K).

6.1.1.6. Calculation of the Corrected Concentration of Pollutants in the Sampling Bag

Equation 13

$$C_i = C_e - C_d \left( 1 - \frac{1}{DiF} \right)$$

where:

C<sub>i</sub> = Concentration of the pollutant i in the diluted exhaust gas, expressed in ppm and corrected by the amount of i contained in the dilution air.

$C_e$  = Measured concentration of pollutant  $i$  in the diluted exhaust gas, expressed in ppm.

$C_d$  = Measured concentration of pollutant  $i$  in the air used for dilution, expressed in ppm.

DiF = Dilution factor

The dilution factor is calculated as follows:

Equation 14

$$\text{DiF} = \frac{X}{C_{\text{CO}_2} + (C_{\text{HC}} + C_{\text{CO}}) \times 10^{-4}}$$

(For each reference fuel, except hydrogen)

For a fuel of composition  $C_xH_yO_z$ , the general formula is:

Equation 15

$$X = 100 * \frac{x}{x + \frac{y}{2} + 3.76 * \left( x + \frac{y}{4} + \frac{z}{2} \right)}$$

Equation 16

For hydrogen, the dilution factor is calculated as follows:

$$\text{DiF} = \frac{X}{C_{\text{H}_2\text{O}} - C_{\text{H}_2\text{O-DA}} + C_{\text{H}_2} \times 10^{-4}}$$

Equation 17

For  $\text{H}_2\text{NG}$  the formula is:

$$X = \frac{65.4 * A}{4.922 * A + 195.84}$$

For the reference fuels contained in Appendix 2, the values of 'X' are as follows:

**Table 3**  
**Factor 'X' in formulae to calculate DF**

Fuel	X
Petrol (E5)	13.4
Diesel B7)	13.5
LPG	11.9
NG/biomethane	9.5
Ethanol (E85)	12.5
Hydrogen	35.03
CNG	9.5

In these equations:

$C_{CO_2}$	=	concentration of CO <sub>2</sub> in the diluted exhaust gas contained in the sampling bag, expressed in percent by volume,
$C_{HC}$	=	concentration of HC in the diluted exhaust gas contained in the sampling bag, expressed in ppm carbon equivalent,
$C_{CO}$	=	concentration of CO in the diluted exhaust gas contained in the sampling bag, expressed in ppm
$C_{H_2O}$	=	concentration of H <sub>2</sub> O in the diluted exhaust gas contained in the sampling bag, expressed in percent by volume,
$C_{H_2O-DA}$	=	concentration of H <sub>2</sub> O in the air used for dilution, expressed in percent by volume,
$C_{H_2}$	=	concentration of hydrogen in the diluted exhaust gas contained in the sampling bag, expressed in ppm,
A	=	quantity of NG/biomethane in the H <sub>2</sub> NG mixture, expressed in percent by volume.

6.1.1.7. **Determination of the NO<sub>x</sub> Humidity Correction Factor**

In order to correct the influence of humidity on the results of oxides of nitrogen, the following calculations are applied.

Equation 18

$$k_H = \frac{1}{1 - 0.0329(H - 10.71)}$$

in which :

$$H = \frac{6.211 * R_a * P_d}{P_B - P_d * R_a * 10^{-2}}$$

where:

H = Absolute humidity expressed in grams of water per kg of dry air

R<sub>a</sub> = Relative humidity of the ambient air expressed in percentage

P<sub>d</sub> = Saturation vapour pressure at ambient temperature expressed in kPa

P<sub>B</sub> = Atmospheric pressure in the room, expressed in kPa

6.1.1.8. **Special provision relating to vehicles equipped with compression-ignition engines**

6.1.1.8.1. HC measurement for compression-ignition engines

The average HC concentration used in determining the HC mass emissions from compression-ignition engines is calculated with the aid of the following formula:

Equation 19

$$C_e = \frac{\int_{t_1}^{t_2} C_{HC} \cdot dt}{t_2 - t_1}$$

Where

$\int_{t_1}^{t_2} C_{HC} \cdot dt$  = Integral of the recording of the heated FID over the test ( $t_2 - t_1$ )

$C_e$  = concentration of HC measured in the diluted exhaust in ppm of  $C_i$

$C_1$  is substituted directly for  $C_{HC}$  in all relevant equations.

6.1.1.8.2.

Determination of particulates matter mass:

Particulate emission  $M_p$  (mg/km) is calculated by means of the following equation:

Equation 20

$$M_p = \frac{(V_{mix} + V_{ep}) * P_e}{V_{ep} * d}$$

Where exhaust gases are vented outside tunnel;

Equation 21

$$M_p = \frac{V_{mix} * P_e}{V_{ep} * d}$$

Where exhaust gases are returned to the tunnel.

where:

$V_{mix}$  : volume of diluted exhaust gases (see Equation 12) under standard conditions.

$V_{ep}$  : volume of exhaust gas flowing through particulate filter under standard conditions.

$P_e$  : particulate mass collected by filters.

$D$  : actual distance corresponding to the operating cycle in km.

$M_p$  : particulate emission in mg/km

Where correction for the particulate background level from the dilution system has been used, this shall be determined in accordance with clause 5.2.1.5 of this Chapter. In this case, the particulate mass (mg/km) shall be calculated as follows:

Equation 22

$$M_p = \left[ \frac{P_e}{V_{ep}} - \left( \frac{P_a}{V_{ap}} * \left( 1 - \frac{1}{DiF} \right) \right) \right] * \frac{(V_{mix} + V_{ep})}{S}$$

where exhaust gases are vented outside the tunnel;

Equation 23

$$M_p = \left[ \frac{P_e}{V_{ep}} - \left( \frac{P_a}{V_{ap}} * \left( 1 - \frac{1}{DiF} \right) \right) \right] * \frac{V_{mix}}{S}$$

where exhaust gases are returned to the tunnel;

where:

$V_{ap}$  = volume of tunnel air flowing through the background particulate filter under standard conditions;

$P_a$  = particulate mass collected by background filter;  
 $DiF$  = dilution factor defined in clause 6.1.1.4.7 of this Chapter.

Where application of a background correction results in a negative particulate mass (in mg/km), the result shall be considered to be zero mg/km particulate mass.

6.1.2. **Fuel Consumption Analysis**

6.1.2.1. **Calculation of fuel consumption**

6.1.2.1.1. The fuel consumption, expressed in litres per 100 km (in the case of gasoline (E5/E10), LPG, ethanol (E85/E100) and diesel (B7)), in m<sup>3</sup> per 100 km (in the case of NG/biomethane and H<sub>2</sub>NG) or in kg per 100km (in the case of hydrogen) is calculated by means of the following formulae:

a) For vehicles with a positive ignition engine fuelled with gasoline (E5):

$$FC = (0.118/D) \times [(0.848 \times HC) + (0.429 \times CO) + (0.273 \times CO_2)];$$

b) For vehicles with a positive ignition engine fuelled with gasoline (E10):

$$FC = (0.120/D) \times [(0.830 \times HC) + (0.429 \times CO) + (0.273 \times CO_2)]$$

c) For vehicles with a positive ignition engine fuelled with LPG:

$$FC_{norm} = (0.1212/0.538) \times [(0.825 \times HC) + (0.429 \times CO) + (0.273 \times CO_2)]$$

If the composition of the fuel used for the test differs from the composition that is assumed for the calculation of the normalized consumption, on the manufacturer's request a correction factor cf may be applied, as follows:

$$FC_{norm} = (0.1212/0.538) \times (cf) \times [(0.825 \times HC) + (0.429 \times CO) + (0.273 \times CO_2)]$$

The correction factor cf, which may be applied, is determined as follows:

$$cf = 0.825 + 0.0693 \times n_{actual}$$

Where:

$n_{actual}$  = the actual H/C ratio of the fuel used;

d) For vehicles with a positive ignition engine fuelled with NG/biomethane:

$$FC_{norm} = (0.1336/0.654) \times [(0.749 \times HC) + (0.429 \times CO) + (0.273 \times CO_2)]$$

e) For vehicles with a compression ignition engine fuelled with diesel (B5):

$$FC = (0.116/D) \times [(0.861 \times HC) + (0.429 \times CO) + (0.273 \times CO_2)]$$

f) For vehicles with a compression ignition engine fuelled with diesel (B7):

$$FC = (0.116/D) \times [(0.859 \times HC) + (0.429 \times CO) + (0.273 \times CO_2)]$$

g) For vehicles with a positive ignition engine fuelled with ethanol (E85):

$$FC = (0.1742/D) \times [(0.574 \times HC) + (0.429 \times CO) + (0.273 \times CO_2)]$$

h) For vehicles with a positive ignition engine fuelled by H2NG:

$$FC = \left( \frac{910.4 * A + 13.600}{44.655 * A^2 + 667.08 * A} \right) * \left( \frac{7.848 * A}{9.104 * A + 136} * HC + 0.429 * CO + 0.273 * CO_2 \right)$$

i) For vehicles fuelled by gaseous hydrogen

$$FC = 0.024 \frac{V}{d} \left[ \frac{1}{Z_1} \frac{p_1}{T_1} - \frac{1}{Z_2} \frac{p_2}{T_2} \right]$$

Under previous agreement with the Test Agency, and for vehicles fuelled either by gaseous or liquid hydrogen, the manufacturer may choose as alternative to the method above, either the formula

$$FC = 0.1 \times (0.1119 \times H_2O + H_2)$$

For vehicles powered by internal combustion engine only, or a method according to standard protocols such as SAE J2572 or ISO 23828.

In these formulae:

FC = the fuel consumption in litre per 100km (in the case of gasoline (E5/E10), ethanol, LPG, diesel (B7) or biodiesel) or in m<sup>3</sup> per 100km (in the case of natural gas and H<sub>2</sub>NG) or in kg per 100km in the case of hydrogen.

HC = The measured emission of hydrocarbons in g/km;

CO = The measured emission of carbon monoxide in g/km;

CO<sub>2</sub> = The measured emission of carbon dioxide in g/km;

H<sub>2</sub>O = The measured emission of H<sub>2</sub>O in g/km

H<sub>2</sub> = The measured emission of H<sub>2</sub> in g/km

A = Quantity of NG/biomethane within the H<sub>2</sub>NG mixture, expressed in per cent Volume

D = The density of the test fuel. In the case of gaseous fuels this is the density at 15°C

D = The theoretical distance covered by a vehicle tested under the Type I test in km.

p<sub>1</sub> = Pressure in gaseous fuel tank before the operating cycle in Pa;

p<sub>2</sub> = Pressure in gaseous fuel tank after the operating cycle in Pa;

T<sub>1</sub> = Temperature in gaseous fuel tank before the operating cycle in K.

T<sub>2</sub> = Temperature in gaseous fuel tank after the operating cycle in K.

Z<sub>1</sub> = Compressibility factor of the gaseous fuel at p<sub>1</sub> and T<sub>1</sub>

Z<sub>2</sub> = compressibility factor of the gaseous fuel at p<sub>2</sub> and T<sub>2</sub>

V = Inner volume of the gaseous fuel tank in m<sup>3</sup>

The compressibility factor shall be obtained from the following Table 4 of this Chapter:

**Table 4**  
**compressibility factor**

		T (K)									
		5	100	200	300	400	500	600	700	800	900
p(bar)	33	0.859	1.051	1.885	2.648	3.365	4.051	4.712	5.352	5.973	6.576
	53	0.965	0.922	1.416	1.891	2.338	2.765	3.174	3.57	3.954	4.329
	73	0.989	0.991	1.278	1.604	1.923	2.229	2.525	2.81	3.088	3.358
	93	0.997	1.042	1.233	1.47	1.711	1.947	2.177	2.4	2.617	2.829
	113	1	1.066	1.213	1.395	1.586	1.776	1.963	2.146	2.324	2.498
	133	1.002	1.076	1.199	1.347	1.504	1.662	1.819	1.973	2.124	2.271
	153	1.003	1.079	1.187	1.312	1.445	1.58	1.715	1.848	1.979	2.107
	173	1.003	1.079	1.176	1.285	1.401	1.518	1.636	1.753	1.868	1.981
	193	1.003	1.077	1.165	1.263	1.365	1.469	1.574	1.678	1.781	1.882
	213	1.003	1.071	1.147	1.228	1.311	1.396	1.482	1.567	1.652	1.735
	233	1.004	1.071	1.148	1.228	1.312	1.397	1.482	1.568	1.652	1.736
	248	1.003	1.069	1.141	1.217	1.296	1.375	1.455	1.535	1.614	1.693
	263	1.003	1.066	1.136	1.207	1.281	1.356	1.431	1.506	1.581	1.655
	278	1.003	1.064	1.13	1.198	1.268	1.339	1.409	1.48	1.551	1.621
	293	1.003	1.062	1.125	1.19	1.256	1.323	1.39	1.457	1.524	1.59
	308	1.003	1.06	1.12	1.182	1.245	1.308	1.372	1.436	1.499	1.562
	323	1.003	1.057	1.116	1.175	1.235	1.295	1.356	1.417	1.477	1.537
	338	1.003	1.055	1.111	1.168	1.225	1.283	1.341	1.399	1.457	1.514
	353	1.003	1.054	1.107	1.162	1.217	1.272	1.327	1.383	1.438	1.493

In the case that the needed input values for p and T are not indicated in the Table, the compressibility factor shall be obtained by linear interpolation between the compressibility factors indicated in the Table, choosing the ones that are the closest to the sought value.

## 7.0 RECORDS REQUIRED

The following information shall be recorded with respect to each test:

- Test number,
- System or device tested (brief description),
- Date and time of day for each part of the test schedule,
- Instrument operator,
- Rider or operator,



- f) Test vehicle: make, vehicle identification number, model year, transmission type, odometer reading at initiation of preconditioning, engine displacement, engine family, emission control system, recommended engine speed at idle, nominal fuel tank capacity, inertial loading, actual curb mass recorded at 0 kilometre, and drive wheel tyre pressure.
- g) Dynamometer serial number: as an alternative to recording the dynamometer serial number, a reference to a vehicle test cell number may be used, with the advance approval of the Administration, provided the test cell records show the pertinent instrument information.
- h) All pertinent instrument information such as tuning-gain-serial number- detector number-range. As an alternative, a reference to a vehicle test cell number may be used, with the advance approval of the Administration, provided test cell calibration records show the pertinent instrument information.
- i) Recorder charts: Identify zero, span, exhaust gas, and dilution air sample traces.
- j) Test cell barometric pressure, ambient temperature and humidity.  
**Note:** A central laboratory barometer may be used; provided, that individual test cell barometric pressures are shown to be within  $\pm 0.1$  per cent of the barometric pressure at the central barometer location.
- k) Pressure of the mixture of exhaust and dilution air entering the CVS metering device, the pressure increase across the device, and the temperature at the inlet. The temperature shall be recorded continuously or digitally to determine temperature variations.
- l) The number of revolutions of the positive displacement pump accumulated during each test phase while exhaust samples are being collected. The number of standard cubic meters metered by a critical flow venturi (CFV) during each test phase would be the equivalent record for a CFV-CVS.
- m) The humidity of the dilution air.  
**Note:** If conditioning columns are not used this measurement can be deleted. If the conditioning columns are used and the dilution air is taken from the test cell, the ambient humidity can be used for this measurement.
- n) The driving distance for the test, calculated from the measured roll or shaft revolutions.
- o) The actual roller speed pattern of the test.
- p) The gear use schedule of the test.
- q) The emissions result of the Type I test.
- r) The emissions result of the Type II test.

**APPENDIX 1 TO CHAPTER 2**  
**Symbols and Acronyms**

**Table 1**

<b>Symbol</b>	<b>Definition</b>	<b>Unit</b>
A	Coefficient of polygonal function	—
$a_T$	Rolling resistance force of front wheel	N
B	Coefficient of polygonal function	—
$b_T$	Coefficient of aerodynamic function	$N/(km/h)^2$
C	Coefficient of polygonal function	—
$C_{CO}$	Concentration of carbon monoxide	% vol.
$C_{CO_{corr}}$	Corrected concentration of carbon monoxide	% vol.
$CO_{2c}$	Carbon dioxide concentration of diluted gas, corrected to take account of diluent air	%
$CO_{2d}$	Carbon dioxide concentration in the sample of diluent air collected in bag B	%
$CO_{2e}$	Carbon dioxide concentration in the sample of diluent air collected in bag A	%
$CO_{2m}$	Mass of carbon dioxide emitted during the test part	g/km
$CO_c$	Carbon monoxide concentration of diluted gas, corrected to take account of diluent air	ppm
$CO_d$	Carbon monoxide concentration in the sample of diluent air, collected in bag B	ppm
$CO_e$	Carbon monoxide concentration in the sample of diluent air, collected in bag A	ppm
$CO_m$	Mass of carbon monoxide emitted during the test part	mg/km
$d_0$	Standard ambient relative air density	—
$d_{CO}$	Density of carbon monoxide	$mg/m^3$
$d_{CO_2}$	Density of carbon dioxide	$mg/m^3$
DiF	Dilution factor	—
$d_{HC}$	Density of hydrocarbon	$mg/m^3$
S / d	Distance driven in a cycle part	km
$d_{NOX}$	Density of nitrogen oxide	$mg/m^3$
$d_T$	Relative air density under test condition	—
$\Delta t$	Coast-down time	s
$\Delta t_{ai}$	Coast-down time measured in the first road test	s
$\Delta t_{bi}$	Coast-down time measured in the second road test	s
$\Delta T_E$	Coast-down time corrected for the inertia mass	s
$\Delta t_E$	Mean coast-down time on the chassis dynamometer at the reference speed	s

Symbol	Definition	Unit
$\Delta T_i$	Average coast-down time at specified speed	s
$\Delta t_i$	Coast-down time at corresponding speed	s
$\Delta T_j$	Average coast-down time at specified speed	s
$\Delta T_{road}$	Target coast-down time	s
$\bar{\Delta t}$	Mean coast-down time on the chassis dynamometer without absorption	s
$\Delta v$	Coast-down speed interval ( $2\Delta v = v_1 - v_2$ )	km/h
E	Chassis dynamometer setting error	%
F	Running resistance force	N
F*	Target running resistance force	N
F* <sub>(v0)</sub>	Target running resistance force at reference speed on chassis dynamometer	N
F* <sub>(vi)</sub>	Target running resistance force at specified speed on chassis dynamometer	N
f* <sub>0</sub>	Corrected rolling resistance in the standard ambient condition	N
f* <sub>2</sub>	Corrected coefficient of aerodynamic drag in the standard ambient condition	N/(km/h) <sup>2</sup>
F* <sub>j</sub>	Target running resistance force at specified speed	N
f <sub>0</sub>	Rolling resistance	N
f <sub>2</sub>	Coefficient of aerodynamic drag	N/(km/h) <sup>2</sup>
F <sub>E</sub>	Set running resistance force on the chassis dynamometer	N
F <sub>E (v0)</sub>	Set running resistance force at the reference speed on the chassis dynamometer	N
F <sub>E (v2)</sub>	Set running resistance force at the specified speed on the chassis dynamometer	N
F <sub>f</sub>	Total friction loss	N
F <sub>f (v0)</sub>	Total friction loss at the reference speed	N
F <sub>j</sub>	Running resistance force	N
F <sub>j(v0)</sub>	Running resistance force at the reference speed	N
F <sub>pau</sub>	Braking force of the power absorbing unit	N
F <sub>pau(v0)</sub>	Braking force of the power absorbing unit at the reference speed	N
F <sub>pau(vj)</sub>	Braking force of the power absorbing unit at the specified speed	N
F <sub>T</sub>	Running resistance force obtained from the running resistance table	N

Symbol	Definition	Unit
H	Absolute humidity	mg/km
HC <sub>c</sub>	Concentration of diluted gases expressed in the carbon equivalent, corrected to take account of diluent air	ppm
HC <sub>d</sub>	Concentration of hydrocarbons expressed in the carbon equivalent, in the sample of diluent air collected in bag B	ppm
HC <sub>e</sub>	Concentration of hydrocarbons expressed in the carbon equivalent, in the sample of diluent air collected in bag A	ppm
HC <sub>m</sub>	Mass of hydrocarbon emitted during the test part	mg/km
K <sub>0</sub>	Temperature correction factor for rolling resistance	—
K <sub>h</sub>	Humidity correction factor	—
L	Limit values of gaseous emission	mg/km
M	Test L5 -category vehicle mass	kg
m <sub>fi</sub>	Flywheel equivalent inertia mass	kg
m <sub>i</sub>	Equivalent inertia mass	kg
m <sub>k</sub>	Kerb mass (L5-category vehicle)	kg
m <sub>r</sub>	Equivalent inertia mass of all the wheels	kg
m <sub>ri</sub>	Equivalent inertia mass of all the rear wheel and L5-category vehicle parts rotating with wheel	kg
m <sub>ref</sub>	Reference mass of the L5-category vehicle plus uniform mass of 150 kg	kg
m <sub>rf</sub>	Rotating mass of the front wheel	kg
m <sub>rid</sub>	Rider mass	kg
N	Engine speed	min <sup>-1</sup>
N	Number of data regarding the emission or the test	—
N	Number of revolution made by pump P	—
Ng	Number of forward gears	—
n <sub>idle</sub>	Idling speed	min <sup>-1</sup>
NO <sub>xc</sub>	Nitrogen oxide concentration of diluted gases, corrected to take account of diluent air	ppm
NO <sub>xd</sub>	Nitrogen oxide concentration in the sample of diluent air collected in bag B	ppm
NO <sub>xe</sub>	Nitrogen oxide concentration in the sample of diluent air collected in bag A	ppm
NO <sub>xm</sub>	Mass of nitrogen oxides emitted during the test part	mg/km
P <sub>0</sub>	Standard ambient pressure	kPa

Symbol	Definition	Unit
$P_a$	Ambient/atmospheric pressure	kPa
$P_d$	Saturated pressure of water at the test temperature	kPa
$P_i$	Average under-pressure during the test part in the section of pump P	kPa
$P_n$	Rated engine power	kW
$P_T$	Mean ambient pressure during the test	kPa
$\rho_0$	Standard relative ambient air volumetric mass	kg/m <sup>3</sup>
$r(i)$	Gear ratio in gear i	—
R	Final test result of pollutant emissions, carbon dioxide emission or fuel consumption	mg/km,g/km, 1/100 km
$R_{i1}$	First Type I test results of pollutant emissions	mg/km
$R_{i2}$	Second Type I test results of pollutant emissions	mg/km
$R_{i3}$	Third Type I test results of pollutant emissions	mg/km
S	Rated engine speed	min <sup>-1</sup>
$T_c$	Temperature of the coolant	K
$T_o$	Temperature of the engine oil	K
$T_p$	Temperature of the spark-plug seat/gasket	K
$T_0$	Standard ambient temperature	K
$T_p$	Temperature of the diluted gases during the test part, measured in the intake section of pump P	K
$T_T$	Mean ambient temperature during the test	K
U	Humidity	%
V	Specified speed	
V	Total volume of diluted gas	m <sup>3</sup>
$v_{max}$	Maximum design speed of test vehicle (L-category vehicle)	km/h
$v_0$	Reference vehicle speed	km/h
$V_0$	Volume of gas displaced by pump P during one revolution	m <sup>3</sup> /rev.
$v_1$	Vehicle speed at which the measurement of the coast-down time begins	km/h
$v_2$	Vehicle speed at which the measurement of the coast-down time ends	km/h
$V_i$	Specified vehicle speed selected for the coast-down time measurement	km/h

<b>Table 2</b>		
<b>List of acronyms and symbols</b>		
<b>Item</b>	<b>Unit</b>	<b>Term</b>
LPG	-	liquefied petroleum gas
NG	-	natural gas
H <sub>2</sub> CNG	-	hydrogen-natural gas mixtures
CO	Ppm	carbon monoxide
NO	Ppm	nitric oxide
CO <sub>2</sub>	Ppm	carbon dioxide
C <sub>3</sub> H <sub>8</sub>	Ppm	propane
T <sub>f</sub>	°C	temperature of fuel
T <sub>v</sub>	°C	temperature of fuel vapour
t	minutes	time from start of the fuel tank heat build
m <sub>HC</sub>	grams	mass of hydrocarbon emitted over the test phase
C <sub>HC</sub>	ppm C1	hydrocarbon concentration measured in the enclosure
T	K or °C	ambient chamber temperature
DF	mg/test	deterioration factor for SHED test
V	m <sup>3</sup>	net enclosure volume corrected for the volume of the vehicle
p	kPa	barometric pressure
H/C	-	hydrogen to carbon ratio
m <sub>total</sub>	grams	overall evaporative mass emissions of the vehicle
m <sub>TH</sub>	grams	evaporative hydrocarbon mass emission for the fuel tank heat build
m <sub>HS</sub>	grams	evaporative hydrocarbon mass emission for the hot soak
V <sub>max</sub>	km/h	maximum vehicle speed
R <sub>f</sub>	-	response factor for a particular hydrocarbon species
FID	-	flame ionisation detector
SHED	-	Sealed Housing for Evaporation Determination
r <sup>2</sup>	-	regression correlation coefficient
HC	-	Hydrocarbon

**APPENDIX 2 TO CHAPTER 2**

**TECHNICAL SPECIFICATION OF REFERENCE FUELS**

**1.0 TECHNICAL SPECIFICATION OF REFERENCE FUELS**

- 1.1 Technical Specification of reference fuels shall be as per GSR 889(E) dated 26<sup>th</sup> September 2016 as amended from time to time.

**APPENDIX 3 TO CHAPTER 2  
CHASSIS DYNAMOMETER SYSTEM**

**1.0 SPECIFICATION**

**1.1 General requirements**

1.1.1 The dynamometer shall be capable of simulating road load within one of the following classifications:

- a) Dynamometer with fixed load curve, i.e. a dynamometer whose physical characteristics provide a fixed load curve shape;
- b) Dynamometer with adjustable load curve, i.e. a dynamometer with at least two road load parameters that can be adjusted to shape the load curve.

1.1.2 Dynamometers with electric inertia simulation shall be demonstrated to be equivalent to mechanical inertia systems. The means by which equivalence is established are described in clause 4 of this Appendix

1.1.3 Where the total resistance to progress on the road cannot be reproduced on the chassis dynamometer between speeds of 10 km/h and 120 km/h, it is recommended that a chassis dynamometer with the characteristics defined in clause 1.2 shall be used.

1.1.3.1 The load absorbed by the brake and the chassis dynamometer (internal frictional effects) between the speeds of 0 and 120 km/h is as follows:

Equation 1:

$$F = (a + b * v^2) \pm 0.1 * F_{80} \text{ (without being negative)}$$

where:

F = total load absorbed by the chassis dynamometer (N);

A = value equivalent to rolling resistance (N);

b = value equivalent to coefficient of air resistance (N/(km/h)<sup>2</sup>);

v = vehicle speed (km/h);

F<sub>80</sub> = load at 80 km/h (N). Alternatively, for vehicles that cannot attain 80 km/h the load at the reference vehicle speeds v<sub>j</sub> in Table 1 of this Appendix shall be determined.

**Table 1**

Category v <sub>max</sub> (km/h)	Applicable reference speed, v <sub>j</sub> (km/h)
70-80	50
45-70	40
25-45	30
<25	15



## 1.2 SPECIFIC REQUIREMENTS

- 1.2.1 The setting of the dynamometer shall not be affected by the lapse of time. It shall not produce any vibrations perceptible to the vehicle and likely to impair the vehicles' normal operations.
- 1.2.2 The chassis dynamometer may have one roller or two rollers. In the case of a single roller, the roller diameter shall not be less than 400 mm.
- 1.2.3 It shall be possible to measure and read the indicated load to an accuracy of  $\pm 5$  percent.
- 1.2.4 In the case of a dynamometer with a fixed load curve, the accuracy of the load setting at 80 km/h or of the load setting at the reference vehicle speeds (30 km/h, respectively 15 km/h) referred to in clause 1.1.3.1 for vehicles that cannot attain 80 km/h, shall be  $\pm 5$  percent. In the case of a dynamometer with adjustable load curve, the accuracy of matching dynamometer load to road load shall be  $\pm 5$  percent for vehicle speeds  $> 20$  km/h and  $\pm 10$  percent for vehicle speeds  $\leq 20$  km/h. Below this vehicle speed, dynamometer absorption shall be positive.
- 1.2.5 The total inertia of the rotating parts (including the simulated inertia where applicable) shall be known and shall be within  $\pm 10$  kg of the inertia class for the test.
- 1.2.6 The speed of the vehicle shall be measured by the speed of rotation of the roller (the front roller in the case of a two-roller dynamometer). It shall be measured with an accuracy of  $\pm 1$  km/h at vehicle speeds over 10 km/h. The distance actually driven by the vehicle shall be measured by the movement of rotation of the roller (the front roller in the case of a two-roller dynamometer).

## 2.0 DYANAMOMETER CALIBRATIN PROCEDURE

### 2.1 Introduction

This section describes the method to be used to determine the load absorbed by a dynamometer brake. The load absorbed comprises the load absorbed by frictional effects and the load absorbed by the power-absorption device. The chassis dynamometer is brought into operation beyond the range of test speeds. The device used for starting up the chassis dynamometer is then disconnected; the rotational speed of the driven rollers decreases. The kinetic energy of rollers is dissipated by the power absorption unit and by the frictional effects. This method disregards variations in the roller's internal frictional effects caused by rollers with or without the vehicle. The frictional effects of the rear roller shall be disregarded when this is free.

- 2.2 Calibration of the load indicator at 80 km/h or of the Power indicator referred to in clause 1.1.3.1 of this Appendix for vehicles that cannot attain 80 km/h.

The following procedure shall be used for calibration of the Power indicator to 80 km/h or the applicable Power indicator referred to in clause 1.1.3.1 of this Appendix for vehicles that cannot attain 80 km/h, as a function of the Power absorbed (see also Figure 1 of this Appendix ):

- 2.2.1 Measure the rotational speed of the roller if this has not already been done. A fifth wheel, a revolution counter or some other method may be used.
- 2.2.2 Place the vehicle on the dynamometer or devise some other method for starting up the dynamometer.
- 2.2.3 Use the flywheel or any other system of inertia simulation for the particular inertia class to be used.

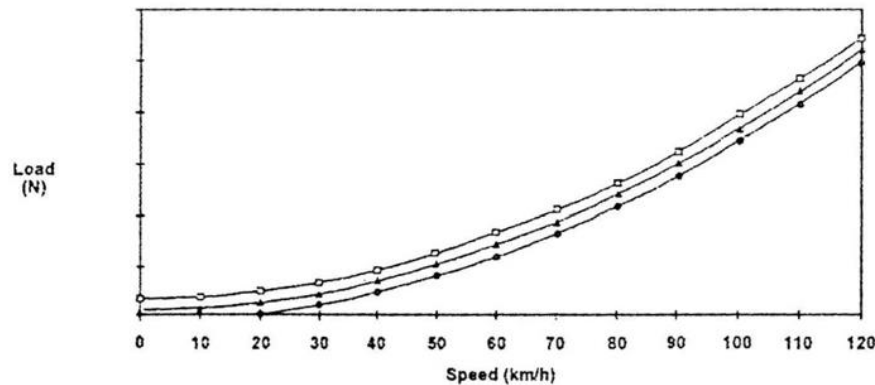

**Figure 1**  
**Power absorbed by the chassis dynamometer**

Legend:

$$\blacktriangle = F = a + b \cdot v^2 \quad \bullet = (a + b \cdot v^2) - 0.1 \cdot F_{80}$$

$$\square = (a + b \cdot v^2) + 0.1 \cdot F_{80}$$

- 2.2.4 Bring the dynamometer to a vehicle speed of 80 km/h or to the reference vehicle speed referred to in clause 1.1.3.1 of this Appendix for vehicles that cannot attain 80 km/h.
- 2.2.5 Note the power indicated ( $P_i$ ).
- 2.2.6 Bring the dynamometer to a speed of 90 km/h or to the respective reference vehicle speed referred to in to in clause 1.1.3.1 of this Appendix plus 5 km/h for vehicles that cannot attain 80 km/h
- 2.2.7 Disconnect the device used to start up the dynamometer.
- 2.2.8 Note the time taken by the dynamometer to pass from a vehicle speed of 85 to 75 km/h, or for vehicles that cannot attain 80 km/h referred to in Table 1 of Appendix 7 of this Chapter note the time between  $v_j + 5$  km/h to  $v_j - 5$  km/h.
- 2.2.9 Set the power-absorption device at a different level.
- 2.2.10 The requirements of clauses 2.2.4 to 2.2.9 of this Appendix shall be repeated sufficiently often to cover the range of road power used.

2.2.11 Calculate the Power absorbed using the formula:

Equation 2

$$P_a = M_i * \frac{V_1^2 - V_2^2}{2000t}$$

where:

Pa = Power absorbed in kW;

M<sub>i</sub>= equivalent inertia in kg (excluding the inertial effects of the free rear roller);

V<sub>1</sub> = initial speed in m/s

V<sub>2</sub> = final speed in m/s

T = time taken by the roller to pass from 85 km/h to 75 km/h in s, or for vehicles that cannot attain 80 km/h, time taken by the roller to pass from 55km/h-45 km/h, 45-35 km/h, 35 – 25 km/h, respectively from 20 – 10 km/h referred to in Table 1 of Appendix 7 of chapter 2.

2.2.12 Figure 2 of this Appendix shows the load indicated at 80 km/h in terms of load absorbed at 80 km/h.

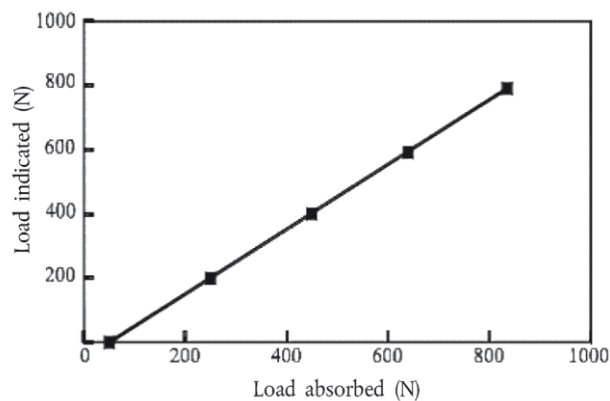

**Figure 2**

**Load indicated at 80 km/h in terms of load absorbed at 80 km/h**

2.2.13 The requirements laid down in clauses 2.2.3 to 2.2.11 of this Appendix shall be repeated for all inertia classes to be used.

**2.3 Calibration of the Power indicator at other speeds**

The procedures described in clause 2.2 of this Appendix shall be repeated as often as necessary for the chosen vehicle speeds.

**2.4 Calibration of force or torque**

The same procedure shall be used for force or torque calibration.

**3.0 VERIFICATION OF THE POWER ABSORPTION CURVE**

**3.1 Procedure**

The Power absorption curve of the dynamometer from a reference setting at a speed of 80 km/h or for vehicles that cannot attain 80 km/h at the respective reference vehicle speeds referred to in clause 1.1.3.1 of this Appendix shall be verified as follows:

- 3.1.1 Place the vehicle on the dynamometer or devise some other method for starting up the dynamometer.
- 3.1.2 Adjust the dynamometer to the absorbed Power  $P_a$  at 80 km/h, or for vehicles that cannot attain 80 km/h to the absorbed power  $F_{v_j}$  at the respective target vehicle speed  $v_j$  referred to in clause 1.1.3.1 of this Appendix
- 3.1.3 Note the Power absorbed at 120, 100, 80, 60, 40 and 20 km/h or for vehicles that cannot attain 80 km/h absorbed at the target vehicles speeds  $v_j$  referred to in clause 1.1.3.1 of this Appendix
- 3.1.4 Draw the curve  $P_a$  versus  $V$  and verify that it corresponds to the requirements of clause 1.1.3.1 of this Appendix
- 3.1.5 Repeat the procedure set out in clauses 3.1.1 to 3.1.4 of this Appendix for other values of Power  $P_a$  at 80 km/h and for other values of inertia.

#### **4.0 VERIFICATION OF SIMULATED INERTIA**

##### **4.1 Object**

The method described in this Appendix makes it possible to check that the simulated total inertia of the dynamometer is carried out satisfactorily in the running phase of the operating cycle. The manufacturer of the chassis dynamometer shall specify a method for verifying the specifications according to clause 4.3 of this Appendix

##### **4.2 Principle**

###### **4.2.1 Drawing-up working equations**

Since the dynamometer is subjected to variations in the rotating speed of the roller(s), the force at the surface of the roller(s) can be expressed by:

Equation 3:

$$F = I * \gamma = I_M * \gamma + F_1$$

where:

$F$  is the force at the surface of the roller(s) in N;

$I$  is the total inertia of the dynamometer (equivalent inertia of the vehicle);

$I_M$  is the inertia of the mechanical masses of the dynamometer;

$\gamma$  is the tangential acceleration at roller surface;

$F_1$  is the inertia force.

Thus, total inertia is expressed as follows:

Equation 4:

$$I = I_m + F_1 / \gamma$$

where:

$I_m$  can be calculated or measured by traditional methods;

$F_1$  can be measured on the dynamometer;

$\gamma$  can be calculated from the peripheral speed of the rollers.

The total inertia (I) will be determined during an acceleration or deceleration test with values no lower than those obtained on an operating cycle.

4.2.2 **Specification for the calculation of total inertia**

The test and calculation methods shall make it possible to determine the total inertia I with a relative error ( $\Delta I/I$ ) of less than  $\pm 2$  percent.

4.3 **Specification**

4.3.1 The mass of the simulated total inertia I shall remain the same as the theoretical value of the equivalent inertia (see Appendix 5 of this chapter) within the following limits:

4.3.1.1  $\pm 5$  percent of the theoretical value for each instantaneous value;

4.3.1.2  $\pm 2$  percent of the theoretical value for the average value calculated for each sequence of the cycle.

The limit specified in clause 4.3.1.1 of this Appendix is brought to  $\pm 50$  percent for one second when starting and, for vehicles with manual transmission, for two seconds during gear change

4.4 **Verification procedure**

4.4.1 Verification is carried out during each test throughout the test cycles defined in Appendix 6 of this chapter.

4.4.2 However, if the requirements laid clown in clause 4.3 of this Appendix are met with instantaneous accelerations which are at least three times greater or smaller than the values obtained in the sequences of the theoretical cycle, the verification described in clause 4.4.1 of this Appendix will not be necessary.

**5.0 TECHNICAL NOTE:**

5.1 **Explanation of drawing up working equations:**

5.1.1. Equilibrium of the forces on the road,

Equation 5:

$$CR = k_1 J r_1 \frac{d\theta_1}{dt} + k_2 J r_2 \frac{d\theta_2}{dt} + k_3 M \gamma_1 + k_3 F_s r_1$$

5.1.2. Equilibrium of the forces on dynamometer with mechanical simulated inertias

Equation 6:

$$\begin{aligned} C_m &= k_1 J r_1 \frac{d\theta_1}{dt} + k_3 \frac{J R_m}{R_m} \frac{dW_m}{dt} r_1 + k_3 F_s r_1 \\ &= k_1 J r_1 \frac{d\theta_1}{dt} + k_3 I \gamma_1 + k_3 F_s r_1 \end{aligned}$$

5.1.3. Equilibrium of the forces of dynamometer with non-mechanically simulated inertias

Equation 7:

$$C_e = k_1 J r_1 \frac{d\theta_1}{dt} + \left( k_3 \frac{J R_e \frac{dW_e}{dt}}{R_e} r_1 + \frac{C_1}{R_e} r_1 \right) + k_3 F_s r_1$$

$$= k_1 J r_1 \frac{d\theta_1}{dt} + k_3 (I_M \gamma + F_1) r_1 + k_3 F_s r_1$$

Where:

- CR = engine torque on the road
- C<sub>m</sub> = engine torque on the chassis dynamometer with mechanically simulated inertias
- C<sub>e</sub> = engine torque on the chassis dynamometer with electrically simulated inertias
- J<sub>r1</sub> = Moment of inertia of the vehicle transmission brought back to the driving wheels
- J<sub>r2</sub> = Moment of inertia of the non-driving wheels
- JR<sub>m</sub> = Moment of inertia of the bench with mechanically simulated inertias
- JR<sub>e</sub> = Moment of mechanical inertia of the chassis dynamometer with electrically simulated inertias
- M = Mass of the vehicle on the road
- I = Equivalent inertia of the chassis dynamometer with electrically simulated inertias
- IM = Mechanical Inertia of the chassis dynamometer with electrically simulated inertia.
- F<sub>s</sub> = Resultant force at stabilized speed.
- C<sub>1</sub> = Resultant torque from electrically simulated inertias
- F<sub>1</sub> = Resultant force from electrically simulated inertias
- dθ<sub>1</sub> / dt = Angular acceleration of the driving wheels
- dθ<sub>2</sub> / dt = Angular acceleration of the non-driving wheels
- dW<sub>m</sub> / dt = Angular acceleration of the mechanical chassis dynamometer
- dW<sub>e</sub> / dt = Angular acceleration of the electrical chassis dynamometer
- γ = Linear acceleration
- r<sub>1</sub> = Radius under load of the driving wheels

$r_2$	=	Radius under load of the non-driving wheels
$R_m$	=	Radius of the rollers of the mechanical chassis dynamometer
$R_e$	=	Radius of the rollers of the electrical chassis dynamometer
$k_1$	=	Coefficient dependent on the gear reduction ratio and the various inertias of transmission and "efficiency"
$k_2$	=	Ratio transmission * $(r_1/r_2)$ * "efficiency"
$k_3$	=	Ratio transmission * "efficiency"

5.1.4 Supposing the two types of bench (Clauses 5.1.2 and 5.1.3 above of this Appendix) are made equal and simplified, one obtains:

Equation 8:

$$k_3 * (IM * \gamma + F_1) * r_1 = k_3 * I * \gamma * r_1$$

where –

$$I = IM + (F_1 / \gamma).$$

## APPENDIX 4 TO CHAPTER 2 EXHAUST DILUTIONS SYSTEM

### 1.0 SYSTEM SPECIFICATION

#### 1.1 System overview

A full-flow exhaust dilution system shall be used. This requires that the vehicle exhaust be continuously diluted with ambient air under controlled conditions. The total volume of the mixture of exhaust and dilution air shall be measured and a continuously proportional sample of the volume shall be collected for analysis. The quantities of pollutants are determined from the sample concentrations, corrected for the pollutant content of the ambient air and the totalized flow over the test period. The exhaust dilution system shall consist of a transfer tube, a mixing chamber and dilution tunnel, a dilution air conditioning, a suction device and a flow measurement device. Sampling probes shall be fitted in the dilution tunnel as specified in this appendices 3, 4 & 5. The mixing chamber described in this point shall be a vessel, such as those illustrated in Figures 1 Appendix and figure 2 of this Appendix, in which vehicle exhaust gases and the dilution air are combined so as to produce a homogeneous mixture at the chamber outlet.

#### 1.2 General requirements

- 1.2.1 The vehicle exhaust gases shall be diluted with a sufficient amount of ambient air to prevent any water condensation in the sampling and measuring system under any conditions which may occur during a test.
- 1.2.2 The mixture of air and exhaust gases shall be homogeneous at the point where the sampling probe is located (see clause 1.3.3 of this Appendix). The sampling probe shall extract a representative sample of the diluted exhaust gas.
- 1.2.3 The system shall enable the total volume of the diluted exhaust gases to be measured.
- 1.2.4 The sampling system shall be gas-tight. The design of the variable dilution sampling system and the materials that go to make it up shall be such that they do not affect the pollutant concentration in the diluted exhaust gases. Should any component in the system (heat exchanger, cyclone separator, blower, etc.) change the concentration of any of the pollutants in the diluted exhaust gases and the fault cannot be corrected, sampling for that pollutant shall be carried out upstream from that component.
- 1.2.5 All parts of the dilution system that are in contact with raw and diluted exhaust gas shall be designed to minimize deposition or alteration of the particulates or particles. All parts shall be made of electrically conductive materials that do not react with exhaust gas components and shall be electrically grounded to prevent electrostatic effects.
- 1.2.6 If the vehicle being tested is equipped with an exhaust pipe comprising several branches, the connecting tubes shall be connected as near as possible to the vehicle without adversely affecting its operation.



1.2.7 The variable-dilution system shall be designed so as to enable the exhaust gases to be sampled without appreciably changing the back-pressure at the exhaust pipe outlet.

1.2.8 The connecting tube between the vehicle and dilution system shall be so designed as to minimize heat loss.

### 1.3 Specific requirements

#### 1.3.1 Connection to vehicle exhaust

The connecting tube between the vehicle exhaust outlets and the dilution system shall be as short as possible and satisfy the following requirements:

- a) the tube shall be less than 3.6 m long, or less than 6.1 m long if heat insulated. Its internal diameter may not exceed 105 mm;
- b) it shall not cause the static pressure at the exhaust outlets on the test vehicle to differ by more than  $\pm 0.75$  kPa at 50 km/h, or more than  $\pm 1.25$  kPa for the whole duration of the test, from the static pressures recorded when nothing is connected to the vehicle exhaust outlets. The pressure shall be measured in the exhaust outlet or in an extension having the same diameter, as near as possible to the end of the pipe. Sampling systems capable of maintaining the static pressure to within  $\pm 0.25$  kPa may be used if a written request from a manufacturer to the test agency substantiates the need for the closer tolerance;
- c) it shall not change the nature of the exhaust gas;
- d) any elastomeric connectors employed shall be as thermally stable as possible and have minimum exposure to the exhaust gases.

#### 1.3.2 Dilution air conditioning

The dilution air used for the primary dilution of the exhaust in the CVS tunnel shall be passed through a medium capable of reducing particles in the most penetrating particle size of the filter material by  $\geq 99.95$  percent, or through a filter of at least class H13 of EN 1822:1998. This represents the specification of High Efficiency Particulate Air (HEPA) filters. The dilution air may be charcoal scrubbed before being passed to the HEPA filter. It is recommended that an additional coarse particle filter is situated before the HEPA filter and after the charcoal scrubber, if used. At the vehicle manufacturer's request, the dilution air may be sampled according to good engineering practice to determine the tunnel contribution to background particulate mass levels, which can then be subtracted from the values measured in the diluted exhaust.

#### 1.3.3 Dilution tunnel

Provision shall be made for the vehicle exhaust gases and the dilution air to be mixed. A mixing orifice may be used. In order to minimize the effects on the conditions at the exhaust outlet and to limit the drop in pressure inside the dilution-air conditioning device, if any, the pressure at the mixing point shall not differ by more than  $\pm 0.25$  kPa from atmospheric pressure. The homogeneity of the mixture in any cross-section at the location of the sampling probe shall not vary by

more than  $\pm 2$  percent from the average of the values obtained for at least five points located at equal intervals on the diameter of the gas stream. For particulate and particle emissions sampling, a dilution tunnel shall be used which:

- a) shall consist of a straight tube of electrically-conductive material, which shall be earthed;
- b) shall be small enough in diameter to cause turbulent flow (Reynolds number  $\geq 4000$ ) and of sufficient length to cause complete mixing of the exhaust and dilution air;
- c) shall be at least 200 mm in diameter;
- d) may be insulated.

#### 1.3.4 **Suction device**

This device may have a range of fixed speeds to ensure sufficient flow to prevent any water condensation. This result is generally obtained if the flow is either:

- a) twice the maximum flow of exhaust gas produced by accelerations of the driving cycle; or
- b) sufficient to ensure that the CO<sub>2</sub> concentration in the dilute exhaust sample bag is less than 3 percent by volume for petrol and diesel, less than 2.2 percent by volume for LPG and less than 1.5 percent by volume for NG/biomethane.

#### 1.3.5 **Volume measurement in the primary dilution system**

The method for measuring total dilute exhaust volume incorporated in the constant volume sampler shall be such that measurement is accurate to  $\pm 2$  percent under all operating conditions. If the device cannot compensate for variations in the temperature of the mixture of exhaust gases and dilution air at the measuring point, a heat exchanger shall be used to maintain the temperature to within  $\pm 6$  K ( $\pm 6^{\circ}\text{C}$ ) of the specified operating temperature. If necessary, some form of protection for the volume measuring device may be used, e.g. a cyclone separator, bulk stream filter, etc. A temperature sensor shall be installed immediately before the volume measuring device. This sensor shall have an accuracy and a precision of  $\pm 1\text{K}$  ( $\pm 1^{\circ}\text{C}$ ) and a response time of 0.1s at 62 percent of a given temperature variation (value measured in silicone oil). The difference from atmospheric pressure shall be measured upstream and, if necessary, downstream from the volume measuring device. The pressure measurements shall have a precision and an accuracy of  $\pm 0.4\text{kPa}$  during the test.

#### 1.3.6. **Gas sampling**

##### 1.3.6.1. **Dilute exhaust gases**

1.3.6.1.1. The sample of dilute exhaust gases is taken before the suction devices but after the conditioning devices (if any).

1.3.6.1.2. The flow-rate shall not deviate by more than  $\pm 2$  percent from the average.

1.3.6.1.3 The sampling rate shall not fall below 5litres per minute and shall not exceed 0.2 percent of the flow-rate of the dilute exhaust gases

1.3.6.1.4 An equivalent limit applies to constant-mass sampling systems.

1.3.6.2. **Dilution air**

1.3.6.2.1 A sample of the dilution air is taken at a constant flow-rate near the ambient air inlet (after the filter if one is fitted).

1.3.6.2.2 The air shall not be contaminated by exhaust gases from the mixing area.

1.3.6.2.3 The sampling rate for the dilution air shall be comparable to that used in the case of the dilute exhaust gases.

1.3.6.3. **Sampling operations**

1.3.6.3.1 The materials used for the sampling operations shall be such that they do not change the pollutant concentration.

1.3.6.3.2 Filters may be used in order to extract the solid particles from the sample.

1.3.6.3.3 Pumps are required in order to convey the sample to the sampling bag(s).

1.3.6.3.4 Flow control valves and flow-meters are needed in order to obtain the flow-rates required for sampling.

1.3.6.3.5 Quick fastening gas-tight connections may be used between the three-way valves and the sampling bags, the connections sealing themselves automatically on the bag side. Other systems may be used for conveying the samples to the analyzer (three-way stop valves, for example).

1.3.6.3.6 The various valves used for directing the sampling gases shall be of the quick-adjusting and quick-acting type.

1.3.6.4 **Storage of the sample**

The gas samples are collected in sampling bags of adequate capacity so as not to reduce the sampling rate. The bags shall be made of such a material as will not change the concentration of synthetic pollutant gases by more than  $\pm 2$  percent after 20 minutes.

1.4 **Recommended system descriptions**

Figure 1 and Figure 2 of this Appendix are schematic drawings of two types of recommended exhaust dilution systems that meet the requirements of this Chapter. Since various configurations can produce accurate results, exact conformity with these figures is not essential. Additional components such as instruments, valves, solenoids and switches may be used to provide additional information and coordinate the functions of the component system.

## 1.4.1 Full-flow dilution system with positive displacement pump

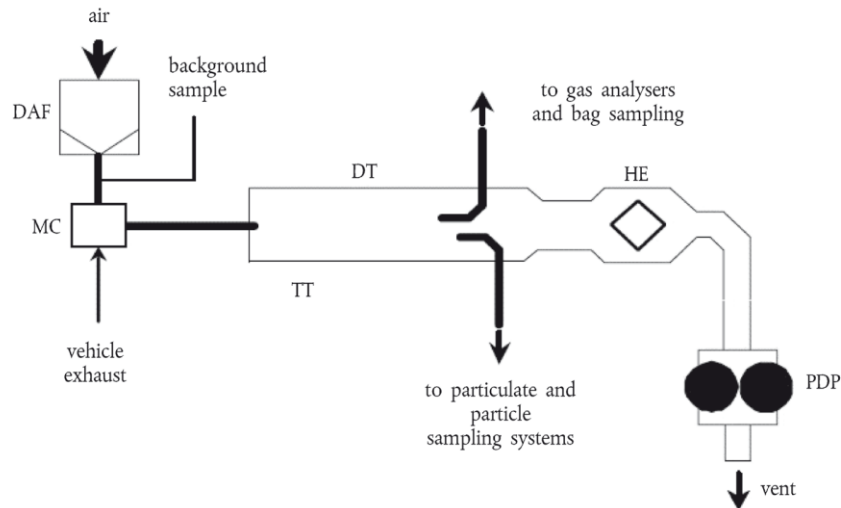
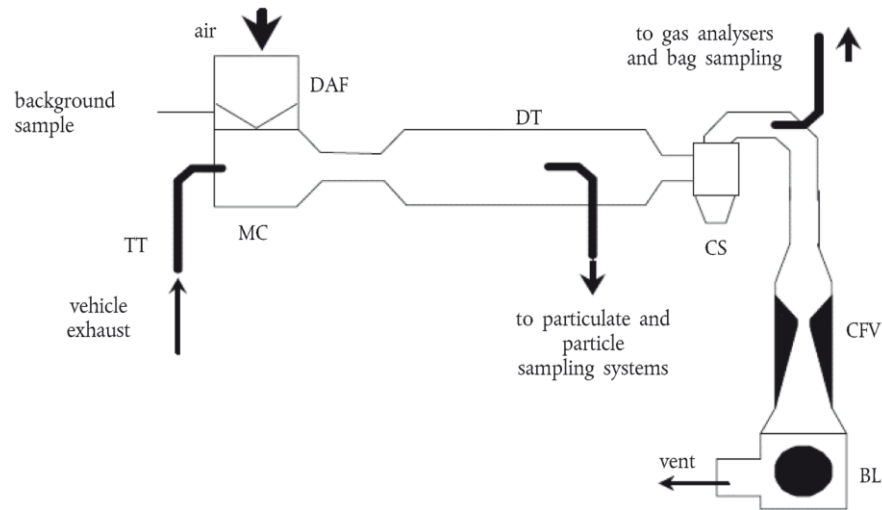

**Figure 1**  
**Positive displacement pump dilution system**

The positive displacement pump (PDP) full-flow dilution system satisfies the requirements of this Chapter by metering the flow of gas through the pump at constant temperature and pressure. The total volume is measured by counting the revolutions of the calibrated positive displacement pump. The proportional sample is achieved by sampling with pump, flow meter and flow control valve at a constant flow rate. The collecting equipment consists of:

- 1.4.1.1 A filter (refer to DAF in Figure 1 of this Appendix) for the dilution air shall be installed, which can be preheated if necessary.
- This filter shall consist of the following filters in sequence: an optional activated charcoal filter (inlet side) and a high efficiency particulate air (HEPA) filter (outlet side). It is recommended that an additional coarse particle filter is situated before the HEPA filter and after the charcoal filter, if used. The purpose of the charcoal filter is to reduce and stabilize the hydrocarbon concentrations of ambient emissions in the dilution air.
- 1.4.1.2 A transfer tube (TT) by which vehicle exhaust is admitted into a dilution tunnel (DT) in which the exhaust gas and dilution air are mixed homogeneously.
- 1.4.1.3 The positive displacement pump (PDP), producing a constant-volume flow of the air/exhaust-gas mixture. The PDP revolutions, together with associated temperature and pressure measurement, are used to determine the flow rate;
- 1.4.1.4 A heat exchanger (HE) of a capacity sufficient to ensure that throughout the test the temperature of the air/exhaust-gas mixture measured at a point immediately upstream of the positive displacement pump is within 6K (6 °C) of the average operating temperature during the test. This device shall not affect the pollutant concentrations of diluted gases taken off afterwards for analysis.

- 1.4.1.5 A mixing chamber (MC) in which exhaust gas and air are mixed homogeneously and which may be located close to the vehicle so that the length of the transfer tube (TT) is minimized.
- 1.4.2 **Full-flow dilution system with critical-flow venturi**



**Figure 2**  
**Critical-flow venturi dilution system**

The use of a critical-flow venturi (CFV) for the full-flow dilution system is based on the principles of flow mechanics for critical flow. The variable mixture flow rate of dilution and exhaust gas is maintained at sonic velocity which is directly proportional to the square root of the gas temperature. Flow is continually monitored, computed and integrated throughout the test. The use of an additional critical-flow sampling venturi ensures the proportionality of the gas samples taken from the dilution tunnel. As pressure and temperature are both equal at the two venturi inlets, the volume of the gas flow diverted for sampling is proportional to the total volume of diluted exhaust-gas mixture produced and thus the requirements of this Chapter are met. The collecting equipment consists of:

- 1.4.2.1 A filter (DAF) for the dilution air which can be preheated if necessary. This filter shall consist of the following filters in sequence: an optional activated charcoal filter (inlet side) and a high efficiency particulate air (HEPA) filter (outlet side). It is recommended that an additional coarse particle filter is situated before the HEPA filter and after the charcoal filter, if used. The purpose of the charcoal filter is to reduce and stabilize the hydrocarbon concentrations of ambient emissions in the dilution air;
- 1.4.2.2 A mixing chamber (MC) in which exhaust gas and air are mixed homogeneously and which may be located close to the vehicle so that the length of the transfer tube (TT) is minimized;
- 1.4.2.3 A dilution tunnel (DT) from which particulates and particles are sampled;

- 1.4.2.4 Some form of protection for the measurement system may be used, e.g. a cyclone separator, bulk stream filter, etc.;
- 1.4.2.5 A measuring critical-flow venturi tube (CFV) to measure the flow volume of the diluted exhaust gas;
- 1.4.2.6 A blower (BL) of sufficient capacity to handle the total volume of diluted exhaust gas.

## **2.0 CVS CALIBRATION PROCEDURE**

### **2.1 General requirements**

The CVS system shall be calibrated by using an accurate flow-meter and a restricting device. The flow through the system shall be measured at various pressure readings and the control parameters of the system measured and related to the flows. The flow-meter shall be dynamic and suitable for the high flow-rate encountered in CVS testing. The device shall be of certified accuracy traceable to an approved national or international standard.

- 2.1.1 Various types of flow-meter may be used, e.g. calibrated venturi, laminar flow-meter, calibrated turbine-meter, provided that they are dynamic measurement systems and can meet the requirements of clause 1.3.5 of this Appendix.
- 2.1.2 The following points give details of methods of calibrating PDP and CFV units, using a laminar flow-meter which gives the required accuracy, together with a statistical check on the calibration validity.

### **2.2 Calibration of the Positive Displacement Pump (PDP)**

- 2.2.1 The following calibration procedure outlines the equipment, the test configuration and the various parameters that are measured to establish the flow-rate of the CVS pump. All the parameters relating to the pump are simultaneously measured with the parameters relating to the flow-meter which is connected in series with the pump. The calculated flow rate (given in m<sup>3</sup>/min at pump inlet, absolute pressure and temperature) can then be plotted against a correlation function that is the value of a specific combination of pump parameters. The linear equation that relates the pump flow and the correlation function is then determined. If a CVS has a multiple speed drive, a calibration shall be performed for each range used.
- 2.2.2 This calibration procedure is based on the measurement of the absolute values of the pump and flow-meter parameters that relate to the flow rate at each point. Three conditions shall be maintained to ensure the accuracy and integrity of the calibration curve:
  - 2.2.2.1 The pump pressures shall be measured at tappings on the pump rather than at the external piping on the pump inlet and outlet. Pressure taps that are mounted at the top centre and bottom centre of the pump drive head plate are exposed to the actual pump cavity pressures and therefore reflect the absolute pressure differentials;





- 2.2.5 After the system has been connected as shown in Figure 3 of this Appendix, set the variable restrictor in the wide-open position and run the CVS pump for 20 minutes before starting the calibration.
- 2.2.6 Reset the restrictor valve to a more restricted condition in an increment of pump inlet depression (about 1 kPa) that will yield a minimum of 6 data points for the total calibration. Allow the system to stabilise for three minutes and repeat the data acquisition.
- 2.2.7 The air flow rate ( $Q_s$ ) at each test point is calculated in standard m<sup>3</sup>/min from the flow-meter data using the manufacturer's prescribed method.
- 2.2.8 The air flow-rate is then converted to pump flow ( $V_0$ ) in m<sup>3</sup>/rev at absolute pump inlet temperature and pressure.

Equation 1:

$$V_0 = \frac{Q_s}{n} * \frac{T_p}{273.2} * \frac{101.33}{P_p}$$

where:

$V_0$  = pump flow rate at  $T_p$  and  $P_p$  (m<sup>3</sup>/rev);

$Q_s$  = air flow at 101.33 kPa and 20K (20°C) (m<sup>3</sup>/min);

$T_p$  = pump inlet temperature (K);

$P_p$  = absolute pump inlet pressure (kPa);

$n$  = pump speed (min<sup>-1</sup>).

- 2.2.9 To compensate for the interaction of pump speed pressure variations at the pump and the pump slip rate, the correlation function ( $x_0$ ) between the pump speed ( $n$ ), the pressure differential from pump inlet to pump outlet, and the absolute pump outlet pressure is calculated as follows:

Equation 2:

$$x_0 = \frac{1}{n} \sqrt{\frac{\Delta P_p}{P_e}}$$

where:

$x_0$  = correlation function;

$\Delta P_p$  = pressure differential from pump inlet to pump outlet (kPa);

$P_e$  = absolute outlet pressure (PPO +  $P_b$ ) (kPa).

- 2.2.9.1 A linear least-square fit is performed to generate the calibration equations which have the formula:

Equation 3:

$$V_0 = D_0 - M * (x_0)$$

$$n = A - B * (\Delta P_p)$$

$D_0$ ,  $M$ ,  $A$  and  $B$  are the slope-intercept constants describing the lines



- 2.2.10. A CVS system that has multiple speeds shall be calibrated on each speed used. The calibration curves generated for the ranges shall be approximately parallel and the intercept values ( $D_0$ ) shall increase as the pump flow range decreases.
- 2.2.11 If the calibration has been performed carefully, the calculated values from the equation will be within 0.5 percent of the measured value of  $V_0$ . Values of  $M$  will vary from one pump to another. Calibration is performed at pump start-up and after major maintenance.

2.3 **Calibration of the Critical-Flow Venturi (CFV)**

- 2.3.1 Calibration of the CFV is based on the flow equation for a critical-flow venturi:

Equation 4:

$$Q_s = \frac{K_v P}{\sqrt{T}}$$

where:

$Q_s$  = flow;

$K_v$  = calibration coefficient;

$P$  = absolute pressure (kPa);

$T$  = absolute temperature (K).

Gas flow is a function of inlet pressure and temperature. The calibration procedure described in clauses 2.3.2 to 2.3.7 of this Appendix shall establish the value of the calibration coefficient at measured values of pressure, temperature and air flow.

- 2.3.2 The manufacturer's recommended procedure shall be followed for calibrating electronic portions of the CFV.
- 2.3.3 Measurements for flow calibration of the critical-flow venturi are required and the following data shall be found within the limits of precision given:

Barometric pressure (corrected) ( $P_b$ )  $\pm 0.03$  kPa

LFE air temperature, flow-meter (ETI)  $\pm 0.15$  °K ( $\pm 0.15$  °C)

Pressure depression upstream of LFE (EPI)  $\pm 0.01$  kPa

Pressure drop across (EDP) LFE matrix  $\pm 0.0015$  kPa

Air flow ( $Q_s$ )  $\pm 0.5$  percent

CFV inlet depression (PPI)  $\pm 0.02$  kPa

Temperature at venturi inlet ( $T_v$ )  $\pm 0.2$  K ( $\pm 0.2$  °C).

- 2.3.4 The equipment shall be set up as shown in Figure 4 of this Appendix and checked for leaks. Any leaks between the flow- measuring device and the critical-flow venturi will seriously affect the accuracy of the calibration.

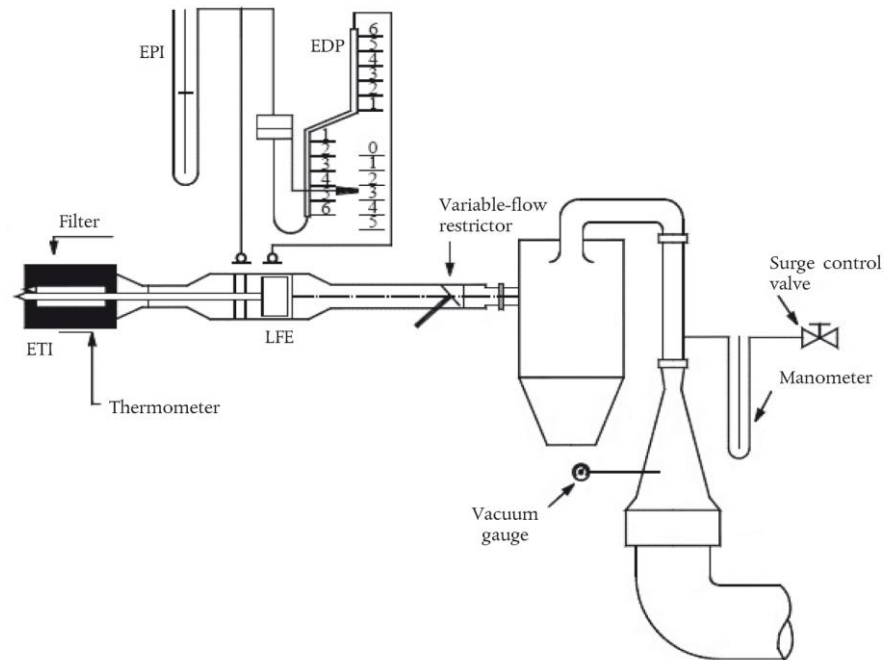

**Figure 4**  
**CFV calibration configuration**

- 2.3.5 The variable-flow restrictor shall be set to the open position, the blower shall be started and the system stabilized. Data from all instruments shall be recorded.
- 2.3.6 The flow restrictor shall be varied and at least 8 readings shall be taken across the critical flow range of the venturi.
- 2.3.7 The data recorded during the calibration shall be used in the following calculations. The air flow-rate ( $Q_s$ ) at each test point is calculated from the flow-meter data using the manufacturer's prescribed method. Calculate values of the calibration coefficient ( $K_v$ ) for each test point:

Equation 5:

$$K_v = \frac{Q_s \sqrt{T_v}}{P_v}$$

$Q_s$  = flow-rate in  $\text{m}^3/\text{min}$  at 20K ( $20^\circ\text{C}$ ) and 101.3 kPa

$T_v$  = temperature at the venturi inlet (K);

$P_v$  = absolute pressure at the venturi inlet (kPa).

Plot  $K_v$  as a function of venturi inlet pressure. For sonic flow,  $K_v$  will have a relatively constant value. As pressure decreases (vacuum increases), the venturi becomes unchoked and  $K_v$  decreases. The resultant  $K_v$  changes are not permissible. For a minimum of 8 points in the critical region, calculate an average  $K_v$  and the standard deviation. If the standard deviation exceeds 0.3 percent of the average  $K_v$ , take corrective action.

### **3.0 SYSTEM VERIFICATION PROCEDURE**

#### **3.1 General requirements**

The total accuracy of the CVS sampling system and analytical system shall be determined by introducing a known mass of a pollutant gas into the system while it is being operated as if during a normal test and then analyzing and calculating the pollutant mass according to the formula in clause 4, except that the density of propane shall be taken as 1.967 grams per litre at standard conditions. The two techniques described in clauses 3.2 and 3.3 are known to give sufficient accuracy. The maximum permissible deviation between the quantity of gas introduced and the quantity of gas measured is 5 percent.

#### **3.2 CFO method**

3.2.1 Metering a constant flow of pure gas (CO or C<sub>3</sub>H<sub>8</sub>) using a critical-flow orifice device

3.2.2 A known quantity of pure gas (CO or C<sub>3</sub>H<sub>8</sub>) is fed into the CVS system through the calibrated critical orifice. If the inlet pressure is high enough, the flow-rate (q), which is adjusted by means of the critical-flow orifice, is independent of orifice outlet pressure (critical flow). If deviations exceeding 5 percent occur, the cause of the malfunction shall be determined and corrected. The CVS system is operated as in an exhaust emission test for about five to ten minutes. The gas collected in the sampling bag is analysed by the usual equipment and the results compared to the concentration of the gas samples which was known beforehand.

#### **3.3 Gravimetric method**

3.3.1 Metering a limited quantity of pure gas (CO or C<sub>3</sub>H<sub>8</sub>) by means of a gravimetric technique

3.3.2 The following gravimetric procedure may be used to verify the CVS system. The weight of a small cylinder filled with either carbon monoxide or propane is determined with a precision of  $\pm 0.01$  g. For about five to ten minutes, the CVS system is operated as in a normal exhaust emission test, while CO or propane is injected into the system. The quantity of pure gas involved is determined by means of differential weighing. The gas accumulated in the bag is analysed using the equipment normally used for exhaust-gas analysis. The results are then compared to the concentration figures computed previously

## APPENDIX 5 TO CHAPTER 2

## CLASSIFICATION OF EQUIVALENT INERTIA MASS AND RUNNING RESISTANCE

- 1.0** The chassis dynamometer can be set using the running resistance table instead of the running resistance force obtained by the coast-down methods set out in Appendix 7 of chapter 2.
- 2.0** The flywheel equivalent inertia mass  $m_{fi}$  shall be the equivalent inertia mass  $m_i$  specified in clause 4.4.5.1.2 of Chapter 2. The chassis dynamometer shall be set by the rolling resistance of front wheel 'a' and the aerodynamic drag coefficient 'b' specified in the following table.

Reference mass $m_{ref}$ (kg)	Equivalent inertia mass $M_i$ (kg)	Rolling resistance of front wheel a (N)	Aero drag coefficient b (N/(km/h) <sup>2</sup> )
295 < $m_{ref}$ ≤ 305	300	26.4	0.0245
305 < $m_{ref}$ ≤ 315	310	27.3	0.0247
315 < $m_{ref}$ ≤ 325	320	28.2	0.0248
325 < $m_{ref}$ ≤ 335	330	29.0	0.0250
335 < $m_{ref}$ ≤ 345	340	29.9	0.0251
345 < $m_{ref}$ ≤ 355	350	30.8	0.0253
355 < $m_{ref}$ ≤ 365	360	31.7	0.0254
365 < $m_{ref}$ ≤ 375	370	32.6	0.0256
375 < $m_{ref}$ ≤ 385	380	33.4	0.0257
385 < $m_{ref}$ ≤ 395	390	34.3	0.0259
395 < $m_{ref}$ ≤ 405	400	35.2	0.0260
405 < $m_{ref}$ ≤ 415	410	36.1	0.0262
415 < $m_{ref}$ ≤ 425	420	37.0	0.0263
425 < $m_{ref}$ ≤ 435	430	37.8	0.0265
435 < $m_{ref}$ ≤ 445	440	38.7	0.0266
445 < $m_{ref}$ ≤ 455	450	39.6	0.0268
455 < $m_{ref}$ ≤ 465	460	40.5	0.0269
465 < $m_{ref}$ ≤ 475	470	41.4	0.0271
475 < $m_{ref}$ ≤ 485	480	42.2	0.0272
485 < $m_{ref}$ ≤ 495	490	43.1	0.0274
495 < $m_{ref}$ ≤ 505	500	44.0	0.0275
505 < $m_{ref}$ ≤ 515	510	44.9	0.0277
515 < $m_{ref}$ ≤ 525	520	45.8	0.0278
525 < $m_{ref}$ ≤ 535	530	46.6	0.0280
535 < $m_{ref}$ ≤ 545	540	47.5	0.0281
545 < $m_{ref}$ ≤ 555	550	48.4	0.0283
555 < $m_{ref}$ ≤ 565	560	49.3	0.0284
565 < $m_{ref}$ ≤ 575	570	50.2	0.0286
575 < $m_{ref}$ ≤ 585	580	51.0	0.0287
585 < $m_{ref}$ ≤ 595	590	51.9	0.0289
595 < $m_{ref}$ ≤ 605	600	52.8	0.0290
605 < $m_{ref}$ ≤ 615	610	53.7	0.0292

**AIS-137 (Part 2)**

615 < m <sub>ref</sub> ≤ 625	620	54.6	0.0293
625 < m <sub>ref</sub> ≤ 635	630	55.4	0.0295
635 < m <sub>ref</sub> ≤ 645	640	56.3	0.0296
645 < m <sub>ref</sub> ≤ 655	650	57.2	0.0298
655 < m <sub>ref</sub> ≤ 665	660	58.1	0.0299
665 < m <sub>ref</sub> ≤ 675	670	59.0	0.0301
675 < m <sub>ref</sub> ≤ 685	680	59.8	0.0302
685 < m <sub>ref</sub> ≤ 695	690	60.7	0.0304
695 < m <sub>ref</sub> ≤ 705	700	61.6	0.0305
705 < m <sub>ref</sub> ≤ 715	710	62.5	0.0307
715 < m <sub>ref</sub> ≤ 725	720	63.4	0.0308
725 < m <sub>ref</sub> ≤ 735	730	64.2	0.0310
735 < m <sub>ref</sub> ≤ 745	740	65.1	0.0311
745 < m <sub>ref</sub> ≤ 755	750	66.0	0.0313
755 < m <sub>ref</sub> ≤ 765	760	66.9	0.0314
765 < m <sub>ref</sub> ≤ 775	770	67.8	0.0316
775 < m <sub>ref</sub> ≤ 785	780	68.6	0.0317
785 < m <sub>ref</sub> ≤ 795	790	69.5	0.0319
795 < m <sub>ref</sub> ≤ 805	800	70.4	0.0320
805 < m <sub>ref</sub> ≤ 815	810	71.3	0.0322
815 < m <sub>ref</sub> ≤ 825	820	72.2	0.0323
825 < m <sub>ref</sub> ≤ 835	830	73.0	0.0325
835 < m <sub>ref</sub> ≤ 845	840	73.9	0.0326
845 < m <sub>ref</sub> ≤ 855	850	74.8	0.0328
855 < m <sub>ref</sub> ≤ 865	860	75.7	0.0329
865 < m <sub>ref</sub> ≤ 875	870	76.6	0.0331
875 < m <sub>ref</sub> ≤ 885	880	77.4	0.0332
885 < m <sub>ref</sub> ≤ 895	890	78.3	0.0334
895 < m <sub>ref</sub> ≤ 905	900	79.2	0.0335
905 < m <sub>ref</sub> ≤ 915	910	80.1	0.0337
915 < m <sub>ref</sub> ≤ 925	920	81.0	0.0338
925 < m <sub>ref</sub> ≤ 935	930	81.8	0.0340
935 < m <sub>ref</sub> ≤ 945	940	82.7	0.0341
945 < m <sub>ref</sub> ≤ 955	950	83.6	0.0343
955 < m <sub>ref</sub> ≤ 965	960	84.5	0.0344
965 < m <sub>ref</sub> ≤ 975	970	85.4	0.0346
975 < m <sub>ref</sub> ≤ 985	980	86.2	0.0347
At every 10 kg	At every 10 kg	a = 0.088 × mi (*)	b= 0.000015× mi+0.02(**)
(*) The value shall be rounded to one decimal place. (**) The value shall be rounded to four decimal place			

**APPENDIX 6 TO CHAPTER 2**  
**DRIVING CYCLES & GEAR SHIFT PROCEDURE FOR TYPE I TEST**

**1.0 INTRODUCTION**

1.1 This Appendix describe the Driving cycle and gear shifting procedure need to be followed for Type I test as per procedure laid down in in this part of Chapter 2.

**2.0 DRIVING CYCLE**

2.1 Break down of the operating cycle used for the Type I test is mentioned in following Table 1 of this Appendix

**3.0 GEAR SHIFTING PROCEDURE**

Operating cycle with recommended gear position is mentioned in Figure 1 of this Appendix and as per clause 4.4.4.2.3.1, 4.4.4.2.3.1.1 and 4.4.4.2.3.1.2. of Chapter 2

**Table 1**  
**Operating cycle on the chassis dynamometer (Indian driving cycle)**

No. of operation		Acceleration (m/sec <sup>2</sup> )	Speed (km/h)	Duration of each operation (S)	Cumulative time(s)
01.	Idling	--	—	16	16
02.	Acceleration	0.65	0-14	6	22
03.	Acceleration	0.56	14-22	4	26
04.	Deceleration	-0.63	22-13	4	30
05.	Steady speed	-	13	2	32
06.	Acceleration	0.56	13-23	5	37
07.	Acceleration	0.44	23-31	5	42
08.	Deceleration	-0.56	31-25	3	45
09.	Steady speed	-	25	4	49
10.	Deceleration	-0.56	25-21	2	51
11.	Acceleration	0.45	21-34	8	59
12.	Acceleration	0.32	34-42	7	66
13.	Deceleration	-0.46	42-37	3	69
14.	Steady speed	-	37	7	76
15.	Deceleration	-0.42	37-34	2	78
16.	Acceleration	0.32	34-42	7	85
17.	Deceleration	-0.46	42-27	9	94
18.	Deceleration	-0.52	27-14	7	101
19.	Deceleration	-0.56	14-00	7	108

Type II A: BREAK DOWN BY PHASES			
1	Idling	1-6	14.81
2	Steady speed periods	13	12.04
3	Accelerations	42	38.89
4	Deceleration's	37	34.26
		108	100

B. AVERAGE SPEED DURING TEST: 21.93 km/h;

C. THEORETICAL DISTANCE COVERED PER CYCLE: 0.658 km;

D. EQUIVALENT DISTANCE FOR THE TEST (6 cycles): 3.948 km.

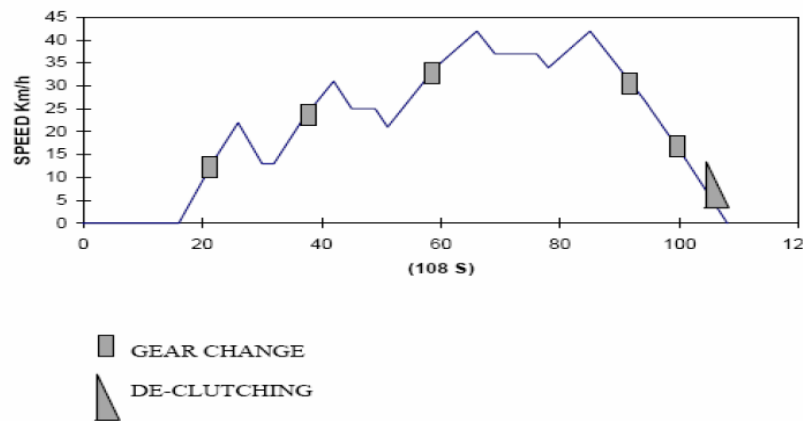

**Figure 1**  
**Operating cycle with recommended gear position**

Acceleration		Deceleration	
Gear	Speed (kmph)	Gear	Speed (kmph)
1 <sup>st</sup> to 2 <sup>nd</sup>	14	4 <sup>th</sup> to 3 <sup>rd</sup>	27
2 <sup>nd</sup> to 3 <sup>rd</sup>	23	3 <sup>rd</sup> to 2 <sup>nd</sup>	14
3 <sup>rd</sup> to 4 <sup>th</sup>	34	Declutch at	8

## APPENDIX 7 TO CHAPTER 2

**RESISTANCE TO PROGRESS OF A VEHICLE MEASUREMENT  
METHOD ON THE ROAD-SIMULATION ON A CHASSIS  
DYNAMOMETER**

**1.0 SCOPE**

- 1.1 This Chapter describes the methods to measure the resistance to the progress of a vehicle at stabilized speeds on the road and to simulate this resistance on a chassis dynamometer with adjustable load curves.

**2.0 DEFINITION OF THE ROAD**

- 2.1 The road shall be level and sufficiently long to enable the measurements specified below to be made. The longitudinal slope shall not exceed 1.5 percent and shall be constant within  $\pm 0.1$  percent over the measuring strip.

**2.2 Atmospheric conditions**

- 2.2.1 **Wind:** Testing shall be limited to wind speeds averaging less than 3 m/s with peak speeds less than 5 m/s. In addition, the vector component of the wind speed across the test road shall be less than 2 m/s. Wind velocity should be measured 0.7 m above the road surface.

- 2.2.2 **Humidity:** The road shall be dry.

- 2.2.3 **Pressure - Temperature:** Air density at the time of the test shall not deviate by more than  $\pm 7.5$  percent from the reference conditions:

$$P = 100 \text{ kPa} \ \& \ T = 293.2 \text{ K} \ (20^{\circ}\text{C})$$

**3.0 VEHICLE PREPARATION:**

- 3.1. **Verifications:** The following verifications shall be made in accordance with the manufacturer's specifications for the use considered:

- a. wheel, wheel rims, tyres (make, type, pressure),
- b. front axle geometry,
- c. brake adjustment (elimination of parasitic drag)
- d. lubrication of front and rear axles,
- e. adjustment of the suspension and vehicle level, etc.

- 3.1.1 **Running in:** refer clause 4.2.2 of Chapter 2 of this part.

- 3.2. Preparation for the test: The vehicle shall be loaded to its reference mass. The level of the vehicle shall be that obtained when the centre of gravity of the load is situated midway between the "R" points of the front outer seats and on a straight line passing through those points.

- 3.2.1 In case of road tests, the windows of the vehicle shall be closed. Any covers of air acclimatization systems, headlamps, etc., shall be in the non-operating position.

- 3.2.2 The vehicle shall be clean.

- 3.2.3 Immediately prior to the test the vehicle shall be brought to normal running temperature in an appropriate manner.



**4.0 METHODS FOR CHASSIS DYNAMOMETER WITH ADJUSTABLE LOAD CURVE**

**4.1 Energy variation during coast-down method :**

4.1.1. On the road

4.1.1.1. Accuracies of test equipment Time shall be measured accurate to within 0.1 second. Speed shall be measured accurate to within 2 percent.

4.1.1.2. Test procedure

4.1.1.2.1 Accelerate the vehicle to a speed of 10 km/h greater than the chosen test speed, V.

4.1.1.2.2 Place the gear box in "neutral" position.

4.1.1.3. Measure the time taken (t1)for the vehicle to decelerate from  $V_2 = V + \Delta V$  km/h to  $V_1 = V - \Delta V$  km/h : with  $3 \leq V \leq 5$  km/h

4.1.1.4. Perform the same test in the opposite direction : t<sub>2</sub>

4.1.1.5. Take the arithmetic mean T, of the two times t<sub>1</sub> and t<sub>2</sub>.

Refer Equation 1 of this Appendix for Average T.

4.1.1.6. Repeat these tests several times such that the statistical accuracy (p) of the arithmetic mean

$$T = \frac{1}{n} \sum_{i=1}^n t_i \text{ is not more than 2 percent ( } p \leq 2\text{percent)}$$

The statistical accuracy (p) is defined by:

$$P = \frac{t*s}{\sqrt{n}} * \frac{100}{T}$$

where,

t = coefficient given by the table below

$$s = \text{standard deviation} = \sqrt{\frac{\sum (T_i - T)^2}{n-1}}$$

n = number of tests

n	4	5	6	7	8	9	10	11	12	13	14	15
T	3.2	2.8	2.6	2.5	2.4	2.3	2.2	2.2	2.2	2.2	2.2	2.2
$\frac{t}{\sqrt{n}}$	1.6	1.25	1.06	0.94	0.85	0.77	0.73	0.66	0.64	0.61	0.59	0.57

4.1.1.7 Calculate the power by the formula:

$$P = \frac{m*V*\Delta V}{500*T}$$

where,

P is expressed in kW

V = speed of the test in m/s

ΔV = speed deviation from speed V, in m/s

m = reference mass in kg

T = time in seconds

#### 4.1.2 **On the chassis dynamometer :**

- 4.1.2.1 Measurement equipment and accuracy: The equipment shall be identical to that used on the road.
- 4.1.2.2 Test procedure:
- 4.1.2.2.1 Install the vehicle on the test dynamometer.
- 4.1.2.2.2 Adjust the tyre pressure (cold) of the driving wheels as required by the chassis dynamometer.
- 4.1.2.2.3 Adjust the equivalent inertia of the chassis dynamometer.
- 4.1.2.2.4 Bring the vehicle and chassis dynamometer to operating temperature in a suitable manner.
- 4.1.2.2.5 Carry out the following operations specified in clause 4.1.1.2 of this Appendix with the exception of clauses 4.1.1.2.4 and 4.1.1.2.5 of the Appendix and with changing  $m$  by  $I$  in the formula of clause 4.1.1.2.7 of this Appendix above.
- 4.1.2.2.6 Adjust the chassis dynamometer such that It shall be possible to measure and read the indicated load to an accuracy of  $\pm 5$  percent.

#### 4.2 **Torque measurements method at constant speed**

##### 4.2.1. **On the road :**

- 4.2.1.1 Measurement equipment and error
- Torque measurement shall be carried out with an appropriate measuring device, accurate to within 2 percent. Speed measurement shall be accurate to within 2 percent.
- 4.2.1.2 Test procedure
- 4.2.1.2.1 Bring the vehicle to the chosen stabilized speed,  $V$ .
- 4.2.1.2.2 Record the torque  $C(t)$  and speed over a period  $t$  (of at least 10 s) by means of class 1000 instrumentation meeting [ISO standard No. 970], over small intervals of time  $t$ .
- 4.2.1.2.3 Differences in torque  $C(t)$ , and speed relative to time shall not exceed 5percent for each second of the measurement period. The torque  $C$  is the average torque derived from the following formula:

$$C_{t1} = \frac{1}{\Delta t} \int_t^{t+\Delta t} C(t) dt$$

- 4.2.1.2.4 Carry out the test in the opposite direction and find out the average torque i.e.  $C_t$ .
- 4.2.1.2.5 Determine the average of these torques  $C_{t1}$  and  $C_{t2}$  i.e.  $C_t$ .

##### 4.2.2 **On the chassis dynamometer**

- 4.2.2.1 Measurement equipment and error: The equipment shall be identical to that used on the road.

- 4.2.2.2 Test procedure
- 4.2.2.2.1 Perform the operations specified in clauses 4.1.2.2.1 to 4.1.2.2.4 of this Appendix above.
- 4.2.2.2.2 Adjust the chassis dynamometer such that It shall be possible to measure and read the indicated load to an accuracy of  $\pm 5$  percent.

4.3 **Integrated torque over vehicle driving pattern:**

- 4.3.1 This method is a non-obligatory complement to the constant speed method described in clause 4.2 above.
- 4.3.2 In this dynamic procedure the mean torque value  $M$  is determined. This is accomplished by integrating the actual torque values,  $M(t)$ , with respect to time during operation of the test vehicle with a defined driving cycle. The integrated torque is then divided by the time difference  $t_2 - t_1$ ,

The result is:

$$\bar{M} = \frac{1}{t_2 - t_1} \int_{t_1}^{t_2} M(t) dt \quad \text{----- (with } M(t) > 0 \text{)}$$

$M$  is calculated from 6 sets of results.

It is recommended that the sampling rate of  $\bar{M}$  be not less than two samples per second.

- 4.3.3 **Dynamometer setting:** The dynamometer load is set by the method described in clause 4.2 above. If  $M$  (dynamometer) does not match  $M$  (road) then the inertia setting shall be adjusted until the values are equal within  $\pm 5$  percent.

**Note:** This method can only be used for dynamometers with electrical inertia simulation or fine adjustment.

- 4.3.3.1 Acceptance criteria:  
Standard deviation of 6 measurements shall be less than or equal to 2 percent of the mean value.

4.4 **Method by deceleration measurement by gyroscopic platform :**

- 4.4.1 On the road :
  - 4.4.1.1 Measurement equipment and accuracy:
    - Speed shall be measured with accuracy better than 2 percent.
    - Deceleration shall be measured with accuracy better than 1 percent.
    - The slope of the road shall be measured with accuracy better than 1percent.
    - Time shall be measured with accuracy better than 0.1 s.
    - The level of the vehicle is measured on a reference horizontal ground: as an alternative, it is possible to correct for the slope of the road ( $a_1$ ).

- 4.4.1.2 Test procedure :
- 4.4.1.2.1 Accelerate the vehicle to a speed 5 km/h greater than the chosen test speed V.
- 4.4.1.2.2 Record the deceleration between V + 0.5 km/h and V - 0.5 km/h.
- 4.4.1.2.3 Calculate the average deceleration attributed to the speed V by the formula:

$$\bar{\gamma}_1 = \frac{1}{t} \int_0^t \gamma_1(t) dt - (g \cdot \sin \alpha_1)$$

where:

$\gamma_1$  = average deceleration value at the speed V in one direction of the road

t = time between V + 0.5 km/h and V - 0.5 km/h

$\gamma_1(t)$  = deceleration recorded with the time

g = 9.81 m/s<sup>2</sup>.

- 4.4.1.2.4 Perform the same test in the other direction  $\gamma_2$
- 4.4.1.2.5 Calculate the average deceleration i.e.

$$\gamma_1 = \frac{\gamma_1 - \gamma_2}{2} \text{ -----for test I}$$

- 4.4.1.2.6. Perform a sufficient number of tests as specified in clause 4.1.1.2.6 of this Appendix replacing T by  $\gamma$  where

$$\gamma = \frac{1}{n} \sum_{i=1}^n \gamma_t$$

- 4.4.1.2.7 Calculate the average force absorbed

$F = m * \gamma$ ,

Where

m = vehicle reference mass in kg.

$\gamma$  = average deceleration calculated as above.

#### 4.4.2. **On the chassis dynamometer**

- 4.4.2.1. Measuring equipment and accuracy The measurement instrumentation of the chassis dynamometer itself shall be used as defined in clause 4.1.2.1 of this Appendix.
- 4.4.2.2. Test procedure Adjustment of the force on the rim under steady speed. On chassis dynamometer, the total resistance is of the type:

$F_{total} = F_{indicated} + F_{driving\ axle\ rolling}$  with

$F_{total} = F_{road}$

$F_{indicated} = F_{road} - F_{driving\ axle\ rolling}$

Where:

F indicated is the force indicated on the force indicating device of the chassis dynamometer. F (road) is known.

33F driving axle rolling can be measured on chassis dynamometer driving axle rolling able to work as generator. The test vehicle, gear box in neutral position, is driven by the dynamometer at the test speed; the rolling resistance,  $R_R$ , of the driving axle is then measured on the force indicating device of the chassis dynamometer.

Determination on chassis dynamometer unable to work as a generator.

For the two-roller chassis dynamometer, the  $R_R$  value is the one which is determined before on the road.

For the single-roller chassis dynamometer, the  $R_R$  value is the one which is determined on the road multiplied by a coefficient R which is equal to the ratio between the driving axle mass and the vehicle total mass.

**Note:**  $R_R$  is obtained from the curve  $F = f(V)$ .

- 4.4.2.2.1. Calibrate the force indicator for the chosen speed of the roller bench as defined in Appendix 3 of this chapter.
- 4.4.2.2.2. Perform the same operation as in clauses 4.1.2.2.1 to 4.1.2.2.4 of this Appendix above.
- 4.4.2.2.3. Set the force,  $F_A = F - F_R$  on the indicator for the speed chosen.
- 4.4.2.2.4. Carry out a sufficient number of tests as indicated in clause 4.1.1.2.6 of this Appendix above, replacing T by  $F_A$ .

#### **4.5. Deceleration method applying coast-down techniques**

##### **4.5.1. On the Road**

- 4.5.1.1. Accuracies of the test instrument shall be the same as specified in 4.1.1.1 of this Appendix.
- 4.5.1.2. Drive the vehicle at a constant speed of about 10 km/h more than the chosen test speed, V km/h, along a straight line.
- 4.5.1.3. After this speed is held steady for a distance of at-least 100 m, disconnect the engine from the drive line by bringing the gear to neutral or by other means in the case of vehicle where manual shifting to neutral is not possible.
- 4.5.1.4. Measure the time taken ( $t_1$  sec) for the speed to drop from  $V + \Delta V$  km/h to  $V - \Delta V$  km/h.

The value of  $\Delta V$  shall not be less than 1 km/h or more than 5 km/h. However, same value of  $\Delta V$  shall be used for all the tests.

- 4.5.1.5. Repeat the test in the opposite direction and record the time (12 sec.).
- 4.5.1.6. Repeat the test 10 times such that the statistical error of the time  $t_i$  (arithmetic average of  $t_1$  and 12) is equal to or less than 2 percent.
- 4.5.1.7. The statistical error 'p' is calculated as –

Equation 9

$$p = \frac{24.24 * (t_i - t_m)^2}{t_m}$$

Where

t = average time for each consecutive set of reading,  $(t_1 + t_2)/2$

$t_m$  = Arithmetic average of 10 such  $t_i$ .

- 4.5.1.8. The basic equation of motion to calculate the road load resistance force, F, is

Equation 10

$$F = \frac{(W + W_2) * V}{(3.6 * t_m * g)}$$

where,

F - in N

W - the weight of the test vehicle in N

$W_2$  - equivalent inertia weight of rotating axle  $(0.035 \times \text{mass of the test vehicle})$  in N

V - vehicle speed difference during the coast down, in km/h

$t_m$  - coast down time, in seconds

g - Acceleration due to gravity,  $9.81 \text{ m/s}^2$ .

- 4.5.1.9. Using least square curve fitting method and values of F and V, the coefficient of rolling and aerodynamic resistance of the vehicle viz. a and b respectively are found from the following equation:

$$F = a + b * V^2$$

- 4.5.2. Chassis Dynamometer Setting: The values of a and b are set on the dynamometer.

4.5.3 **Validity of the equation**

- 4.5.3.1 The above road-load equation can be extrapolated up to speeds 20 percent -above the highest speed at which test has been conducted.

- 4.5.3.2 If the value of ‘a’ so obtained can be extrapolated for load conditions other than the test load, this can be done for loads up to + 10 percent of the test load with following correction:

$$a_{\text{desired}} = a_{\text{tested}} \times \frac{\text{Test Load}_{\text{desired}}}{\text{Test Load}_{\text{tested}}}$$

- 4.6. **Alternative method:** With the manufacturer's agreement, Power absorption table method provided in Appendix 5 of this chapter may be used. The brake is adjusted so as to absorb the load exerted at the driving wheels at constant speed of 50 km/h in accordance with table I of Appendix 5 of this chapter.

## APPENDIX 8 TO CHAPTER 2

### TYPE I TEST PROCEDURE FOR VEHICLES FUELED WITH LPG/NG/BIOMETHANE, H<sub>2</sub>NG OR HYDROGEN

#### 1.0 INTRODUCTION

- 1.1. This Appendix describes the special requirements as regards the testing of LPG, NG/biomethane, H<sub>2</sub>NG or hydrogen gas for the approval of alternative fuel vehicles that run on those fuels or can run on petrol, LPG, NG/biomethane, H<sub>2</sub>NG or hydrogen.
- 1.2. The composition of these gaseous fuels, as sold on the market, can vary greatly and fueling systems shall adapt their fuelling rates accordingly. To demonstrate this adaptability, the parent vehicle equipped with a representative LPG, NG/biomethane or H<sub>2</sub>NG fuel system shall be tested in Type I tests on two extreme reference fuels.
- 1.3. The requirements of this Appendix as regards hydrogen shall apply only to vehicles using hydrogen as a combustion fuel and not to those equipped with a fuel cell operating on hydrogen.
- 1.4. For CNG and LPG vehicles, the provisions of CMV Rule 115(B) and CMV Rule 115(C) as amended from time to time, shall apply.
- 1.5. Vehicles models and variants having option for Bi-fuel operation and fitted with limp-home gasoline tank of capacity not exceeding three litres on three wheelers shall be exempted from test in gasoline mode.

#### 2.0 GRANTING IF THE APPROVAL FOR AN L5-CATEGORY VEHICLE EQUIPPED WITH A GASEOUS FUEL SYSTEM

**Type approval is granted subject to the following requirements:**

##### 2.1. Exhaust emissions approval of a vehicle equipped with a gaseous fuel system

It shall be demonstrated that the parent vehicle equipped with a representative LPG, NG/biomethane, H<sub>2</sub>NG or hydrogen fuel system can adapt to any fuel composition that may appear on the market and comply with the following:

- 2.1.1. In the case of LPG there are variations in C<sub>3</sub>/C<sub>4</sub> composition (test fuel requirement A and B) and therefore the parent vehicle shall be tested on reference fuels A and B referred to in the notification.

Reference Fuel shall be used for Type Approval and Conformity of Production two year after the same is available to the test agencies. Till then, Commercial LPG fuel shall be used as per applicable Gazette Notification under CMVR.

2.1.2. In the case of NG/biomethane there are generally two types of fuel, high calorific fuel (G20) and low calorific fuel (G25), but with a significant spread within both ranges; They differ significantly in Wobbe index. These variations are reflected in the reference fuels. The parent vehicle shall be tested on both reference fuels referred to in the notification.

Reference Fuel shall be used for Type Approval and Conformity of Production two year after the same is available to the test agencies. Till then, Commercial CNG fuel shall be used as per applicable Gazette Notification under CMVR.

2.1.3. In the case of a flex fuel H<sub>2</sub>NG vehicle, the composition range may vary from 0 percent hydrogen (L-gas) to a maximum percentage of hydrogen within the mixture (H-gas), as specified by the manufacturer. It shall be demonstrated that the parent vehicle can adapt to any percentage within the range specified by the manufacturer and the vehicle shall be tested in the Type I test on 100 percent H-gas and 100 percent L-gas. It shall also be demonstrated that it can adapt to any NG/biomethane composition that may appear on the market, regardless of the percentage of hydrogen in the mixture.

2.1.4. For vehicles equipped with hydrogen fuel systems, compliance shall be tested on the single hydrogen reference fuel referred to in notification.

2.1.5. If the transition from one fuel to another is in practice aided through the use of a switch, this switch shall not be used during Type approval. In such cases, at the manufacturer’s request and with the agreement of the test agency, the pre-conditioning cycle referred in clause 4.1.2.1 of Chapter 2 may be extended.

2.1.6. The ratio of emission results ‘r’ shall be determined for each pollutant as shown in Table 1 of this Appendix for LPG, NG/biomethane and H<sub>2</sub>NG vehicles.

2.1.6.1. In the case of LPG and NG/biomethane vehicles, the ratios of emission results ‘r’ shall be determined for each pollutant as follows:

**Table 1**  
**Calculation ratio ‘r’ for LPG and NG/biomethane vehicles**

Type(s) of fuel	Reference fuels	Calculation of ‘r’
LPG and petrol	Fuel A	$r = \frac{A}{B}$
or LPG only	Fuel B	
NG/biomethane	fuel G20	$r = \frac{G25}{G20}$
	fuel G25	

2.1.6.2. In the case of flex fuel H<sub>2</sub>NG vehicles, two ratios of emission results ‘r1’ and ‘r2’ shall be determined for each pollutant as follows:



**Table 2**  
**Look-up table ratio ‘r’ for NG/biomethane or H<sub>2</sub>NG gaseous fuels**

Type(s) of fuel	Reference fuels	Calculation of ‘r’
NG/biomethane	fuel G20	$r_1 = \frac{G25}{G20}$
	fuel G25	
H <sub>2</sub> NG	Mixture of hydrogen and G20 with the maximum percentage of hydrogen specified by the manufacturer	$r_2 = \frac{H_2G25}{H_2G20}$
	Mixture of hydrogen and G25 with the maximum percentage of hydrogen specified by the manufacturer	

## 2.2 Exhaust emissions approval of a member of the propulsion family

For the Type approval of mono-fuel gas vehicles and bi-fuel vehicles operating in gas mode, fuelled by LPG, NG/biomethane, H<sub>2</sub>NG or hydrogen, as a member of the propulsion family in Chapter 8, a Type I test shall be performed with one gaseous reference fuel. For LPG, NG/biomethane and H<sub>2</sub>NG vehicles, this reference fuel may be either of the reference fuels in Appendix 2. The gas-fuelled vehicle is considered to comply if the following requirements are met:

- 2.2.1. The test vehicle shall be selected based on definition of a propulsion family member in Chapter 8.
- 2.2.2. If the test fuel requirement is reference fuel A for LPG or G20 for NG/biomethane, the emission result shall be multiplied by the relevant factor ‘r’ if  $r > 1$ ; if  $r < 1$ , no correction is needed.
- 2.2.3. If the test fuel requirement is reference fuel B for LPG or G25 for NG/biomethane, the emission result shall be divided by the relevant factor ‘r’ if  $r < 1$ ; if  $r > 1$ , no correction is needed.
- 2.2.4. At the manufacturer’s request, the Type I test may be performed on both reference fuels, so that no correction is needed.
- 2.2.5. The parent vehicle shall comply with the emission limits for relevant category set out in BS VI emission norms and for both measured and calculated emissions.
- 2.2.6. If repeated tests are conducted on the same engine, an average shall first be taken of the results on reference fuel G20, or A, and those on reference fuel G25, or B; the ‘r’ factor shall then be calculated from these averages.

- 2.2.7. For the Type approval of a flex fuel H<sub>2</sub>NG vehicle as a member of a family, two Type I tests shall be performed, the first test with 100 percent of either G20 or G25, and the second test with the mixture of hydrogen and the same NG/biomethane fuel used during the first test, with the maximum hydrogen percentage specified by the manufacturer.
- 2.2.7.1. If the NG/biomethane fuel is the reference fuel G20, the emission result for each pollutant shall be multiplied by the relevant factors (r1 for the first test and r2 for the second test) in clause 2.1.6. of the Appendix if the relevant factor > 1; if the correspondent relevant factor < 1, no correction is needed.
- 2.2.7.2. If the NG/biomethane fuel is the reference fuel G25, the emission result for each pollutant shall be divided by the corresponding relevant factor (r1 for the first test and r2 for the second test) calculated in accordance with clause 2.1.6 of this Appendix if this is < 1; if the corresponding relevant factor is > 1, no correction is needed.
- 2.2.7.3. At the manufacturer's request, the Type I test shall be conducted with the four (4) possible combinations of reference fuels, in accordance with clause 2.1.6 of this Appendix so that no correction is needed.
- 2.2.7.4. If repeated tests are carried out on the same engine, an average shall first be taken of the results on reference fuel G20, or H<sub>2</sub>G20, and those on reference fuel G25, or H<sub>2</sub>G25 with the maximum hydrogen percentage specified by the manufacturer; The 'r1' and 'r2' factors shall then be calculated from these averages.
- 2.2.8. During the Type I test, the vehicle shall use only petrol for a maximum of 60 consecutive seconds directly after engine crank and start when operating in gas fuelling mode. In the case of the use of LPG or CNG as a fuel, it is permissible that the engine is started on petrol and switched to LPG or CNG after a predetermined period of time which cannot be changed by the driver.

**APPENDIX 9 TO CHAPTER 2****TYPE I TEST PROCEDURE FOR L5-CATEGORY VEHICLES  
EQUIPPED WITH A PERIODICALLY REGENERATING SYSTEM****1.0 INTRODUCTION**

This Appendix contains specific provisions regarding the Type approval of vehicles equipped with a periodically regenerating system.

**2.0 SCOPE**

Scope of the Type approval for vehicles with a periodically regenerating system as regards Type I tests

- 2.1. L5 - category vehicles that are equipped with periodically regenerating systems shall comply with the requirements in this Appendix.
- 2.2. Instead of carrying out the test procedures in the following point, a fixed  $K_i$  value of 1.05 may be used if the manufacturer sees no reason why this value could be exceeded and after approval of testing agency
- 2.3. During cycles where regeneration occurs, emission standards can be exceeded. If a regeneration of an anti- pollution device occurs at least once per Type I test and that has already regenerated at least once during the vehicle preparation cycle, it will be considered as a continuously regenerating system which does not require a special test procedure.
- 2.4. **"Periodically regenerating system"** means an anti-pollution device (e.g. catalytic converter, particulate trap) that requires a periodical regeneration process in less than 4,000 km of normal vehicle operation. During cycles where regeneration occurs, emission standards can be exceeded. If a regeneration of an anti-pollution device occurs at least once per Type I test and that has already regenerated at least once during vehicle preparation cycle, it will be considered as a continuously regenerating system which does not require a special test procedure. This Appendix does not apply to continuously regenerating systems.

At the request of the manufacturer, the test procedure specific to periodically regenerating systems will not apply to a regenerative device if the manufacturer provides data to the Type Test Agency that, during cycles where regeneration occurs, emissions remain below the standards given in the notification for the concerned vehicle category after agreement of the test agency.

**3.0 TEST PROCEDURE**

The vehicle may be equipped with a switch capable of preventing or permitting the regeneration process provided that its operation has no effect on original engine calibration. This switch shall be used for the purpose of preventing regeneration only during loading of the regeneration system and during the pre-conditioning cycles. However, it shall not be used during the measurement of emissions in the regeneration phase; rather the emission test shall be carried out with the unchanged original equipment manufacturers powertrain control unit / engine control unit / drive train control unit if applicable and powertrain software.

- 3.1. Measurement of carbon dioxide emission / fuel consumption and mass emissions between two cycles where regenerative phases occur.
  - 3.1.1. The average of carbon dioxide emission / fuel consumption and mass emissions between regeneration phases and during loading of the regenerative device shall be determined from the arithmetic mean of several approximately equidistant (if more than two) Type I operating cycles.
 

Carbon dioxide emission / fuel consumption and mass emissions shall be measured for at least two Type I operating cycles: one immediately after regeneration (before new loading) and one as immediately as possible before a regeneration phase. All emissions measurements and calculations shall be carried out in accordance with Chapter 2. Average emissions for a single regenerative system shall be determined in accordance with clause 3.3 of this Appendix and for multiple regeneration systems in accordance with clause 3.4 of this Appendix.
  - 3.1.2. The loading process and  $K_i$  determination shall be carried out on a chassis dynamometer during the Type I operating cycles. These cycles may be run continuously (i.e. without the need to switch the engine off between cycles). After any number of completed cycles, the vehicle may be removed from the chassis dynamometer and the test continued at a later time.
  - 3.1.3. The number of cycles (D) between two cycles in which regeneration phases occur, the number of cycles over which emissions measurements are taken (n) and each emissions measurement ( $M'_{sij}$ ) shall be reported in test report.
- 3.2. Measurement of carbon dioxide emission / fuel consumption and mass emissions during regeneration
  - 3.2.1. If necessary, the vehicle may be prepared for the emissions test during a regeneration phase using the preparation cycles in Appendix 6 of this chapter.
  - 3.2.2. The test and vehicle conditions for the Type I test described in Chapter 2 apply before the first valid emission test is carried out.
  - 3.2.3. Regeneration shall not occur during the preparation of the vehicle. This may be ensured by one of the following methods:
    - 3.2.3.1 A 'dummy' regenerating system or partial system may be fitted for the pre-conditioning cycles;
    - 3.2.3.2 Any other method agreed between the manufacturer and the testing agency.
  - 3.2.4. A cold start exhaust emission test including a regeneration process shall be carried out in accordance with the applicable Type I operating cycle.

- 3.2.5. If the regeneration process requires more than one operating cycle, subsequent test cycle(s) shall be driven immediately, without switching the engine off, until complete regeneration has been achieved (each cycle shall be completed). The time necessary to set up a new test shall be as short as possible (e.g. as required to change a particulate matter filter on the analyzing equipment). The engine shall be switched off during this period.
- 3.2.6. The emission values, during regeneration ( $M_{ri}$ ) shall be calculated in accordance with Type I test procedure described in Chapter 2 and clause 3.3. The number of operating cycles ( $d$ ) measured for complete regeneration shall be recorded.
- 3.3. Calculation of the combined exhaust emissions of a single regenerative system:

Equation 1

$$(1) \quad M_{si} = \frac{\sum_{j=1}^n M'_{sij}}{n} \quad n \geq 2$$

Equation 2

$$(2) \quad M_{ri} = \frac{\sum_{j=1}^d M'_{rij}}{d}$$

Equation 3

$$(3) \quad M_{pi} = \left\{ \frac{M_{si} * D + M_{ri} * d}{D + d} \right\}$$

Where for each pollutant (i) considered:

- $M'_{sij}$  = mass emissions of pollutant (i), mass emissions of CO<sub>2</sub> in g/km / fuel consumption in l/100 km over one Type I operating cycle without regeneration;
- $M'_{rij}$  = mass emissions of pollutant (i), mass emissions of CO<sub>2</sub> in g/km / fuel consumption in l/100 km over one Type I operating cycle during regeneration (when  $n > 1$ , the first Type I test is run cold, and subsequent cycles are hot);
- $K_i$  =  $M_{pi} / M_{si}$  the test agency.  $K_i$  may be determined following the completion of a single sequence.
- $M_{si}$  = mean mass emissions of pollutant (i) in mg/km or mean mass emissions of CO<sub>2</sub> in g/km / fuel consumption in l/100 km over one part (i) of the operating cycle without regeneration;
- $M_{ri}$  = mean mass emissions of pollutant (i) in mg/km or mean mass emissions of CO<sub>2</sub> in g/km / fuel consumption in l/100 km over one part (i) of the operating cycle during regeneration;

- M<sub>pi</sub> = mean mass emissions of pollutant (i) in mg/km or mean mass emissions of CO<sub>2</sub> in g/km / fuel consumption in l/100 km;
- N = number of test points at which emissions measurements (Type I operating cycles) are taken between two cycles where regenerative phases occur, ≥ 2
- D = number of operating cycles required for regeneration.
- D = number of operating cycles between two cycles where regenerative phases occur.

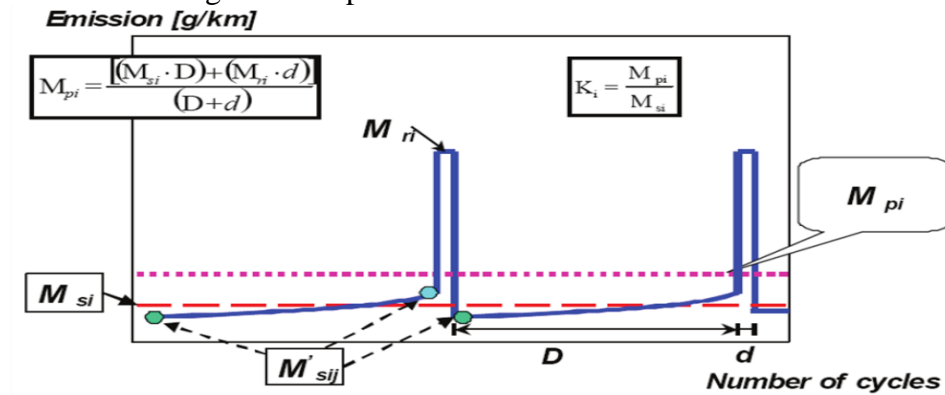

Figure 1

**Example of measurement parameters. Parameters measured during emissions or fuel consumption test during and between cycles in which regeneration occurs (schematic example – the emissions during ‘D’ may increase or decrease)**

- 3.3.1. Calculation of the regeneration factor K for each pollutant (i), carbon dioxide emission / fuel consumption considered:

Equation 4

$$K_i = M_{pi} / M_{si}$$

M<sub>si</sub>, M<sub>pi</sub> and K<sub>i</sub> results shall be recorded in the test report delivered by the test agency. K<sub>i</sub> may be determined following the completion of a single sequence.

- 3.4. Calculation of combined exhaust emissions, carbon dioxide emissions / fuel consumption of multiple periodic regenerating systems

Equation 5

$$(1) \quad M_{sik} = \frac{\sum_{j=1}^{n_k} M'_{sik,j}}{n_k} \quad n_k \geq 2$$

Equation 6

$$(2) \quad M_{rik} = \frac{\sum_{j=1}^{d_k} M'_{rik,j}}{d_j}$$

Equation 7

$$(3) \quad M_{si} = \frac{\sum_{k=1}^x M_{sik} \cdot D_k}{\sum_{k=1}^x D_k}$$

Equation 8

$$(4) \quad M_{ri} = \frac{\sum_{k=1}^x M_{rik} \cdot d_k}{\sum_{k=1}^x d_k}$$

Equation 9

$$(5) \quad M_{pi} = \frac{M_{si} \cdot \sum_{k=1}^x D_k + M_{ri} \cdot \sum_{k=1}^x d_k}{\sum_{k=1}^x (D_k + d_k)}$$

Equation 10

$$(6) \quad M_{pi} = \frac{\sum_{k=1}^x (M_{sik} \cdot D_k + M_{rik} \cdot d_k)}{\sum_{k=1}^x (D_k + d_k)}$$

Equation 11

$$(7) \quad K_i = \frac{M_{pi}}{M_{si}}$$

Where for each pollutant (i) considered:

$M'_{sik}$  = mass emissions of event k of pollutant (i) in mg/km, mass emissions of CO<sub>2</sub> in g/km / fuel consumption in l/100 km over one Type I operating cycle without regeneration;

$M'_{rik}$  = mass emissions of event k of pollutant (i) in mg/km, mass emissions of CO<sub>2</sub> in g/km / fuel consumption in l/100 km over one Type I operating cycle during regeneration (if  $d > 1$ , the first Type I test is run cold, and subsequent cycles are hot);

$M'_{sik,j}$  = mass emissions of event k of pollutant (i) in mg/km, mass emissions of CO<sub>2</sub> in g/km/fuel consumption in l/100 km over one Type I operating cycle without regeneration measured at point j;  $1 \leq j \leq n$ ;

- $M'_{rik,j}$  = mass emissions of event  $k$  of pollutant  $(i)$  in  $\text{mg}/\text{km}$ , mass emissions of  $\text{CO}_2$  in  $\text{g}/\text{km}$  / fuel consumption in  $1/100 \text{ km}$  over one Type I operating cycle during regeneration (when  $j > 1$ , the first Type I test is run cold, and subsequent cycles are hot) measured at operating cycle  $j$ ;  $1 \leq j \leq d$ ;
- $M_{si}$  = mass emission of all events  $k$  of pollutant  $(i)$  in  $\text{mg}/\text{km}$ , of  $\text{CO}_2$  in  $\text{g}/\text{km}$  / fuel consumption in  $1/100 \text{ km}$  without regeneration;
- $M_{ri}$  = mass emission of all events  $k$  of pollutant  $(i)$  in  $\text{mg}/\text{km}$ , of  $\text{CO}_2$  in  $\text{g}/\text{km}$  / fuel consumption in  $1/100 \text{ km}$  during regeneration;
- $M_{pi}$  = mass emission of all events  $k$  of pollutant  $(i)$  in  $\text{mg}/\text{km}$ , of  $\text{CO}_2$  in  $\text{g}/\text{km}$  / fuel consumption in  $1/100 \text{ km}$ ;
- $n_k$  = number of test points of event  $k$  at which emissions measurements (Type I operating cycles) are taken between two cycles in which regenerative phases occur;
- $d_k$  = number of operating cycles of event  $k$  required for regeneration;
- $D_k$  = number of operating cycles of event  $k$  between two cycles in which regenerative phases occur.

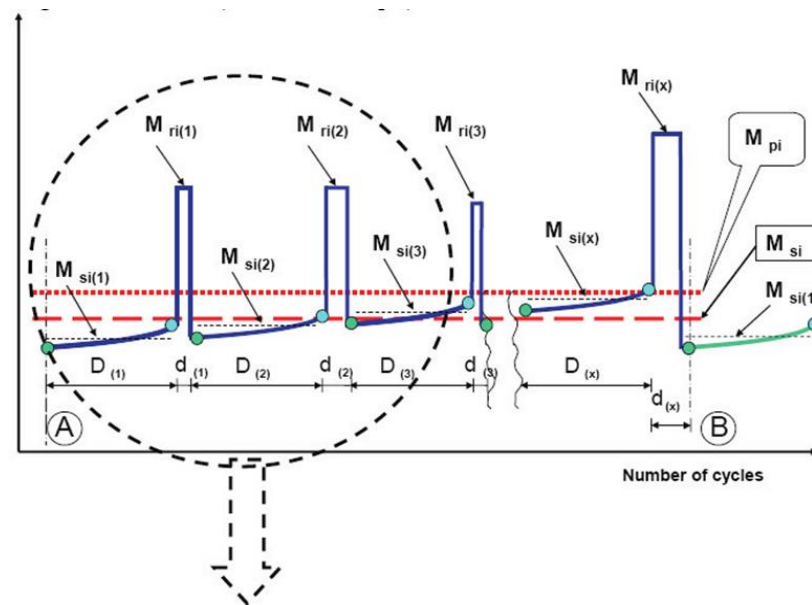

Figure 2

Parameters measured during emissions test during and between cycles in which regeneration occurs (schematic example)

For more details of the schematic process see Figure 3 of this Appendix:



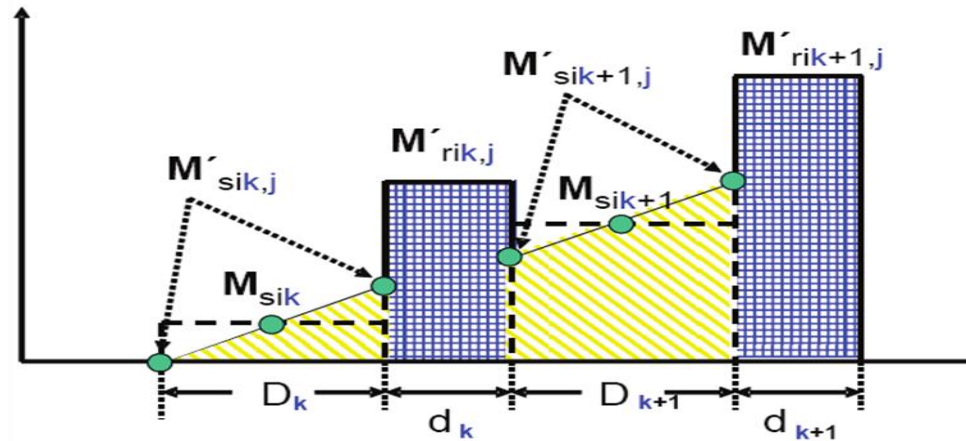

Figure 3

**Parameters measured during emissions test during and between cycles where regeneration occurs (schematic example)**

For application of a simple and realistic case, the following description gives a detailed explanation of the schematic example shown in Figure 3 of this Appendix:

‘Particulate Filter’: regenerative, equidistant events, similar emissions ( $\pm 15$  percent) from event to event

$$D_k = D_{k+1} = D_1$$

$$d_k = d_{k+1} = d_1$$

$$M_{rik} - M_{sik} = M_{rik+1} - M_{sik+1}$$

$$n_k = n$$

‘DeNOx’: the desulphurisation ( $SO_2$  removal) event is initiated before an influence of sulphur on emissions is detectable ( $\pm 15$  percent of measured emissions) and in this example, for exothermic reasons, together with the last DPF regeneration event.

$$M'_{sik,j} = 1 = \text{constant} \quad M_{sik} = M_{sik+1} = M_{si2} \quad M_{rik} = M_{rik+1} = M_{ri2}$$

$$\text{For } SO_2 \text{ removal event: } M_{ri2}, M_{si2}, d_2, D_2, n_2 = 1$$

Complete system (DPF + DeNOx):

Equation 12

$$M_{si} = \frac{n \cdot M_{si1} \cdot D_1 + M_{si2} \cdot D_2}{n \cdot D_1 + D_2}$$

Equation 13

$$M_{ri} = \frac{n \cdot M_{ri1} \cdot d_1 + M_{ri2} \cdot d_2}{n \cdot d_1 + d_2}$$

Equation 14

$$M_{pi} = \frac{M_{si} + M_{ri}}{n \cdot (D_1 + d_1) + D_2 + d_2} = \frac{n \cdot (M_{sil} \cdot D_1 + M_{ril} \cdot d_1) + M_{si2} \cdot D_2 + M_{ri2} \cdot d_2}{n \cdot (D_1 + d_1) + D_2 + d_2}$$

The calculation of the factor ( $K_i$ ) for multiple periodic regenerating systems is possible only after a certain number of regeneration phases for each system. After performing the complete procedure (A to B, see Figure 2 of this Appendix), the original starting conditions A should be reached again.

- 3.4.1. Extension of approval for a multiple periodic regeneration system
- 3.4.1.1. If the technical parameters or the regeneration strategy of a multiple regeneration system for all events within this combined system are changed, the complete procedure including all regenerative devices shall be performed by measurements to update the multiple  $K_i$  – factor.
- 3.4.1.2. If a single device of the multiple regeneration system is changed only in strategy parameters (i.e. such as ‘D’ or ‘d’ for DPF) and the manufacturer can provide the plausible technical data to the test agency and information demonstrating that:

There is no detectable interaction with the other device(s) of the system;  
and

The important parameters (i.e. construction, working principle, volume, location, etc.) are identical,

The necessary update procedure for  $k_i$  may be simplified.

In such cases, where agreed between the manufacturer and the test agency, only a single event of sampling/storage and regeneration shall be performed and the test results (‘ $M_{si}$ ’, ‘ $M_{ri}$ ’), in combination with the changed parameters (‘D’ or ‘d’), may be introduced into the relevant formula (e) to update the multiple  $K_i$  - factor mathematically by substituting the existing basic  $K_i$  - factor formula (e).

## APPENDIX 10 TO CHAPTER 2

### CONFORMITY OF PRODUCTION (COP) - TECHNICAL REQUIREMENTS

#### 1.0 INTRODUCTION

Every produced vehicle of the model approved under this CMV Rule 115 (20) shall conform, with regard to components affecting the emission of gaseous pollutants by the engine to the vehicle model Type approved. The administrative procedure for carrying out conformity of production is given in Part 6 of AIS-137.

#### 2.0 TYPE I TEST VERIFYING THE AVERAGE EMISSION OF GASEOUS POLLUTANTS:

For verifying the conformity of production in a Type I Test, the following procedure as per Option1 is adopted.

2.1 To verify the average tailpipe emissions of gaseous pollutants of low volume vehicles with Annual production less than 250 per 6 months, manufacture can choose from the Option 1 or Option 2 as listed below:

#### 2.2 Run-in

The vehicle shall be run in as per manufacturer's recommendation before the test. The engine, drive train and vehicle shall be properly run in, in accordance with the manufacturer's requirements.

#### 3.0 OPTION 1

3.1 The vehicle samples taken from the series, as described in clause 1 of this appendix is subjected to the single Type-I test described in Chapter 2. The results shall be multiplied by the deterioration factors applied at the time of Type approval. The resultant masses of gaseous emissions and where specified in the notification, the mass of particulates obtained in the test shall not exceed the applicable limits.

3.2 Procedure for Conformity of Production as per Bharat Stage-VI for 3 Wheelers vehicles

3.2.1 Conformity of production shall be verified as per Bharat Stage VI emission norms for 3 wheeler vehicles as given in notification and with the procedure given below.

3.2.2 To verify the average tailpipe emissions of gaseous pollutants following procedure shall be adopted.

3.2.3 With a minimum sample size of three, the sampling procedure is set so that the probability of a lot passing a test with 40 percent of the production defective is 0.95 (producer's risk = 5 percent), while the probability of a lot being accepted with 65 percent of the production defective is 0.1 (consumer's risk = 10 percent).

Minimum of three vehicles shall be selected randomly from the series with a sample lot size as defined in Part 6 of AIS-137.

- 3.2.4 After selection by the testing agency, the manufacturer shall not undertake any adjustments to the vehicles selected, except those permitted in Part 6 of AIS-137.
- 3.2.5 All three randomly selected vehicles shall be tested for a Type-1 test as per Chapter 2
- 3.2.6 Let  $X_{i1}$ ,  $X_{i2}$  &  $X_{i3}$  are the test results for the vehicle Sample No.1, 2 & 3.
- 3.2.7 If the natural Logarithms of the measurements in the series are  $X_1, X_2, X_3, \dots, X_j$  and  $L_i$  is the natural logarithm of the limit value for the pollutant, then define:

$$d_j = X_j - L_i$$

$$\bar{d}_n = \frac{1}{n} \sum_{j=1}^n d_j$$

$$V_n^2 = \frac{1}{n} \sum_{j=1}^n (d_j - \bar{d}_n)^2$$

- 3.2.8 Table 1 of this Appendix shows values of the pass ( $A_n$ ) and fail ( $B_n$ ) decision numbers against current sample number. The test statistic is the ratio  $\bar{d}_n/V_n$  and shall be used to determine whether the series has passed or failed as follows :

Pass the series, if  $\bar{d}_n/V_n \leq A_n$  for all the pollutants

Fail the series if  $\bar{d}_n/V_n \geq B_n$  for any one of the pollutants.

Increase the sample size by one, if  $A_n < \bar{d}_n/V_n < B_n$  for any one of the pollutants. When a pass decision is reached for one pollutant, that decision will not be changed by any additional tests carried out to reach a decision for the other pollutants.

If no pass decision is reached for all the pollutants and no fail decision is reached for one pollutant, a test shall be carried out on another randomly selected sample till a pass or fail decision is arrived at

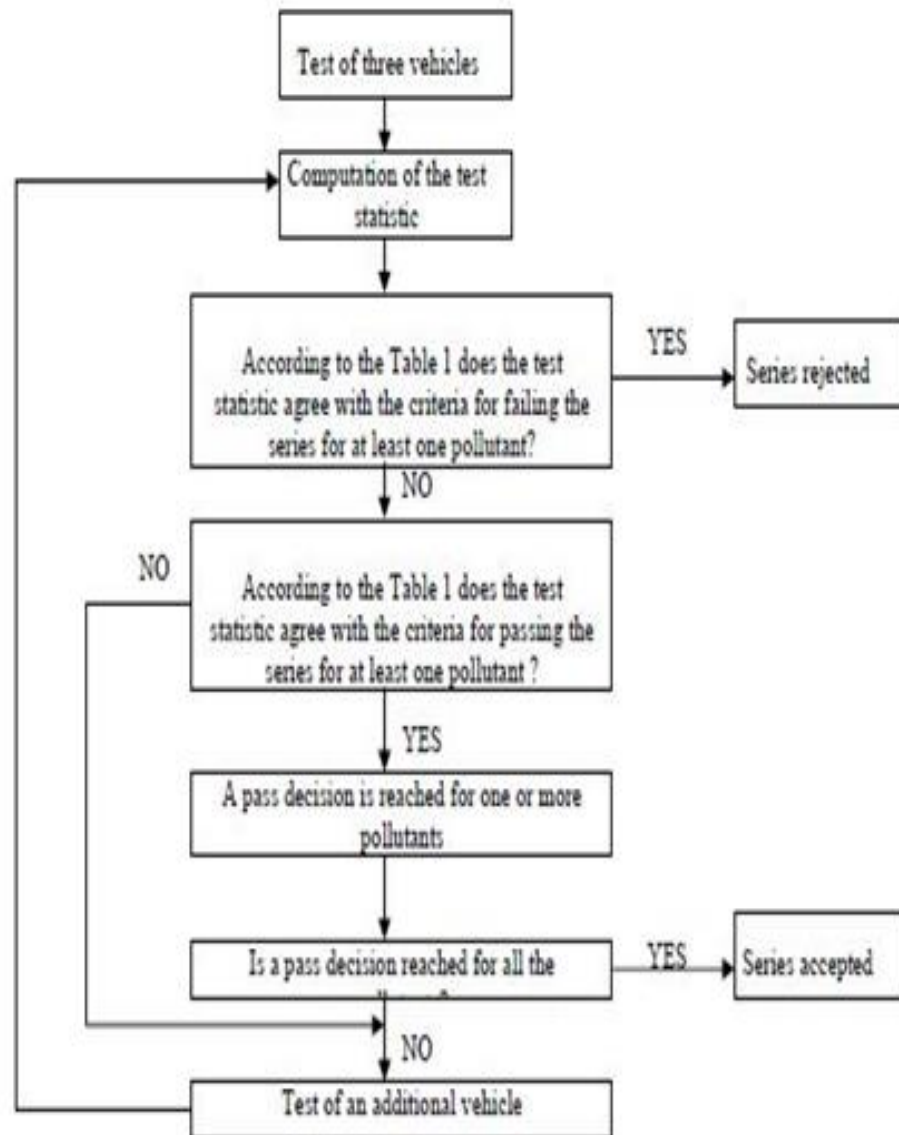

**Figure 1**

**Option I:  
COP Test Procedure as per Bharat Stage VI for 3 wheeler**

**Table 1**  
**Applicable for COP Procedure as per Bharat Stage VI for 3 Wheeler**

<b>Sample Size</b>	<b>Pass Decision threshold (A<sub>n</sub>)</b>	<b>Fail Decision threshold (B<sub>n</sub>)</b>
3	-0.80381	16.64743
4	-0.76339	7.68627
5	-0.72982	4.67136
6	-0.69962	3.25573
7	-0.67129	2.45431
8	-0.64406	1.94369
9	-0.61750	1.59105
10	-0.59135	1.33295
11	-0.56542	1.13566
12	-0.53960	0.97970
13	-0.51379	0.85307
14	-0.48791	0.74801
15	-0.46191	0.65928
16	-0.43573	0.58321
17	-0.40933	0.51718
18	-0.38266	0.45922
19	-0.35570	0.40788
20	-0.32840	0.36203
21	-0.30072	0.32078
22	-0.27263	0.28343
23	-0.24410	0.24943
24	-0.21509	0.21831
25	-0.18557	0.18970
26	-0.15550	0.16328
27	-0.12483	0.13880
28	-0.09354	0.11603
29	-0.06159	0.09480
30	-0.02892	0.07493
31	0.00449	0.05629
32	0.03876	0.03876

#### **4.0 OPTION 2**

- 4.1 Minimum of three vehicles shall be selected randomly from the series with a sample lot size.
- 4.2 After selection by the testing agency, the manufacturer shall not undertake any adjustments to the vehicles selected, except those permitted in Part 6 of AIS-137.
- 4.3 First vehicle out of three randomly selected vehicles shall be tested for Type – I test as per Chapter 2
- 4.4 Only one test (V1) shall be performed if the test results for all the pollutants meet 70 percent of their respective limit values (i.e.  $V1 \leq 0.7L$  & L being the COP Limit)

- 4.5 Only two tests shall be performed if the first test results for all the pollutants doesn't exceed 85percent of their respective COP limit values (i.e.  $V1 \leq 0.85L$ ) and at the same time one of these pollutant value exceeds 70percent of the limit (i.e.  $V1 > 0.7L$ ) In addition, to reach the pass decision for the series, combined results of V1 & V2 shall satisfy such requirement that:  $(V1 + V2) < 1.70L$  and  $V2 < L$  for all the pollutants.
- 4.6 Third Type - I (V3) test shall be performed if the clause 4.11 doesn't satisfy and if the second test results for all pollutants are within the 110percent of the prescribed COP limits, Series passes only if the arithmetical mean for all the pollutants for three Type I tests do not exceed their respective limit value i.e.  $(V1 + V2 + V3)/3 < L$ .
- 4.7 If one of the three test results obtained for any one of the pollutants exceed 10 percent of their respective limit values the test shall be continued on Sample No. 2 & 3 as given in the Figure 2 of this Appendix, as the provision for extended COP and shall be informed by the test agency to the nodal agency.
- 4.8 These randomly selected sample No.2 & 3 shall be tested for only one Type – I test as per Chapter 2
- 4.9 Let  $X_{i2}$  &  $X_{i3}$  are the test results for the Sample No.2 & 3 and  $X_{i1}$  is the test result of the Sample No.1 which is the arithmetical mean for the three Type – I tests conducted on Sample No. 1
- 4.10 If the natural Logarithms of the measurements in the series are  $X_1, X_2, X_3, \dots, X_j$  and  $L_i$  is the natural logarithm of the limit value for the pollutant, then define:

$$d_j = X_j - L_i$$

$$\bar{d}_n = \frac{1}{n} \sum_{j=1}^n d_j$$

$$V_n^2 = \frac{1}{n} \sum_{j=1}^n (d_j - \bar{d}_n)^2$$

- 4.11 Table 1 of this Appendix shows values of the pass ( $A_n$ ) and fail ( $B_n$ ) decision numbers against current sample number. The test statistic is the ratio  $\bar{d}_n / V_n$  and shall be used to determine whether the series has passed or failed as follows: -

Pass the series,  $\bar{d}_n / V_n \geq A_n$  for all the pollutants

Fail the series,  $\bar{d}_n / V_n \geq B_n$  for any one of the pollutants.

Increase the sample size by one, if  $A_n < \bar{d}_n / V_n \leq B_n$  for any one of the pollutants.

- 4.12 When a pass decision is reached for one pollutant, that decision will not be changed by any additional tests carried out to reach a decision for the other pollutants. In extended COP if earlier pass pollutants values are significantly high, then test agency will consider all pollutants for pass fail decision.
- 4.13 If no pass decision is reached for all the pollutants and no fail decision is reached for one pollutant, a test shall be carried out on another randomly selected sample till a pass or fail decision is arrived at.
- 5.0** These tests shall be conducted with the reference fuel as specified in the notification. However, at the manufacturer's request, tests may be carried out with commercial fuel.
- 6.0** **TYPE II TEST: CARBON-MONOXIDE AND HYDROCARBONS EMISSION AT IDLING SPEED:**
- When the vehicle taken from the series for the first Type I test mentioned in clause 2 above, subjected to the test described in Chapter 3 of this Part for verifying the carbon monoxide and hydrocarbon emission at idling speed shall meet the limit values specified in CMVR rule no. 115(2). If it doesn't, another 10 vehicles shall be taken from the series at random and shall be tested as per Chapter 3 of this Part. These vehicles can be same as those selected for carrying out Type I test. Additional vehicles if required shall be selected for carrying out for Type II test. At least 9 out of 10 vehicles shall meet the limit values specified in CMVR rule no. 115(2). Then the series is deemed to conform.
- 7.0** Free Acceleration Smoke Test: Test is to be carried out on vehicles equipped with Compression ignition engines, it must be conducted on all vehicles selected for Type I COP test and should meet the limit values specified in Gazette notification. Test to be carried out in accordance with Chapter 5 to Part 5 of AIS-137



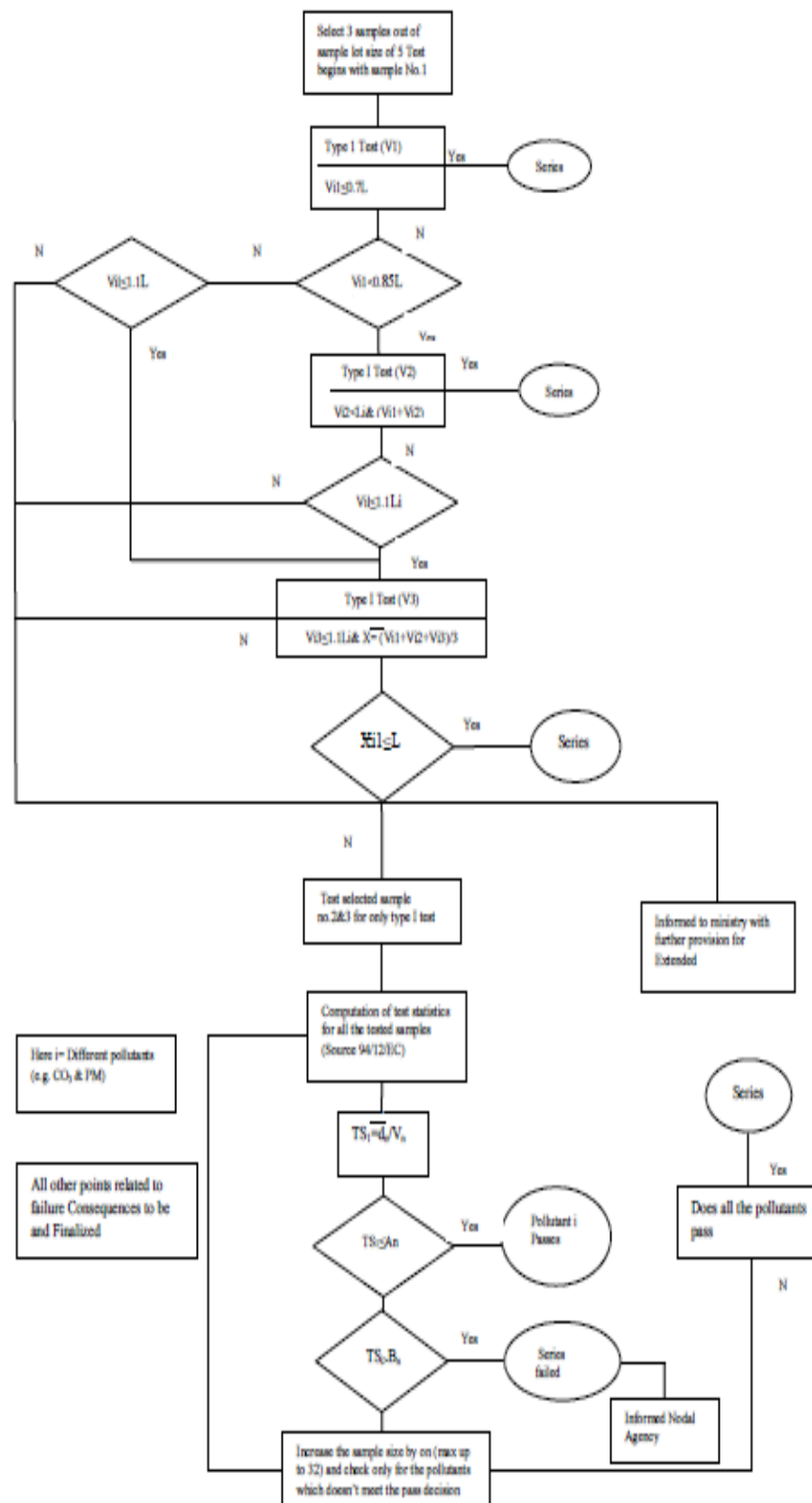

**Figure 2**  
**OPTION II: COP Test Procedure as per Bharat Stage VI for 3W**

**APPENDIX 11 TO CHAPTER 2**  
**TYPE I TEST PROCEDURE FOR HYBRID CATEGORY VEHICLES**

**1.0 INTRODUCTION**

- 1.1. This Appendix defines the specific provisions regarding Type-approval of hybrid electric L5-category vehicles (HEV).
- 1.2. In principle, for the environmental Type I to VIII test, hybrid electric vehicles shall be tested in accordance with this part, unless otherwise provided for in this Appendix.
- 1.3. For the Type I and Type VII tests, off-vehicle charging (OVC) vehicles (as categorized in clause 2 of this Appendix) shall be tested according to Conditions A and B as mentioned in clause 3.1.1 of this Appendix. Both sets of test results and the weighted values shall be reported in the test report drafted in accordance with the template referred to in Chapter 9.
- 1.4. The emissions test results shall comply with the limits set-out the notification under all test conditions specified in this part.

**2.0 CATEGORIES OF HYBRID VEHICLES**

**Table 1**  
**Hybrid vehicle categories**

Vehicle charging	Off-Vehicle Charging ( <sup>1</sup> ) (OVC)		Not-off-vehicle Charging ( <sup>2</sup> ) (NOVC)	
	Without	With	Without	With
Operating mode switch				

(<sup>1</sup>) Also known as ‘externally chargeable’.

(<sup>2</sup>) Also known as ‘not externally chargeable’.

Refer Table 2 of this Appendix

**3.0 TYPE I TEST METHODS**

For the Type I test, hybrid electric L5-category vehicles shall be tested according to the applicable procedure in this part. For each test condition, the pollutant emission test result shall comply with the limits in the notification.

**3.1. Externally chargeable vehicles (OVC HEVs) without an operating mode switch**

**3.1.1. Two tests shall be performed under the following conditions:**

- a) condition A: the test shall be carried out with a fully charged electrical energy device /REESS

- (b) Condition B: the test shall be carried out with an electrical energy device /REESS in minimum state of charge (maximum discharge of capacity).

The profile of the state of charge (SOC) of the electrical energy device / REESS during different stages of the test is given in Appendix 1.1. to Chapter 9,

**3.1.2. Condition A**

3.1.2.1. The procedure shall start with the discharge of the electrical energy device /REESS of the vehicle while driving (on the test track, on a chassis dynamometer, etc.) in any of the following conditions

- (a) at a steady speed of 50 km/h until the fuel-consuming engine starts up;
- (b) if a vehicle cannot reach a steady speed of 50 km/h without the fuel-consuming engine starting up, the speed shall be reduced until it can run at a lower steady speed at which the fuel-consuming engine does not start up for a defined time or distance (to be determined by the test agency and the manufacturer subject to the agreement of the test agency);
- (c) in accordance with the manufacturer's recommendation.

The fuel-consuming engine shall be stopped within ten seconds of being automatically started.

**3.1.2.2. Conditioning of vehicle**

The vehicle shall be conditioned by driving the applicable Type I driving cycle as set out in Appendix 6 of chapter 2.

3.1.2.3. After this preconditioning and before testing, the vehicle shall be kept in a room in which the temperature remains relatively constant between 293 K and 303 K (20 °C and 30 °C). This conditioning shall be carried out for at least six hours and continue until the temperature of the engine oil and coolant, if any, are within  $\pm 2$  K of the temperature of the room, and the electrical energy device /REESS is fully charged as a result of the charging prescribed in clause 3.1.2.4 of this Appendix

3.1.2.4. During soak, the electrical energy device /REESS shall be charged with any of the following

- (a) the on-board charger if fitted;
- (b) an external charger recommended by the manufacturer and referred to in the user manual, using the normal overnight charging procedure set out in clause 3.2.2.4. of Appendix 3 to Chapter 9.

This procedure excludes all types of special charges that could be automatically or manually initiated, e.g. equalization or servicing charges

The manufacturer shall declare that a special charge procedure has not occurred during the test;

End-of-charge criterion.

The end-of-charge criterion corresponds to a charging time of 12 hours, except where the standard instrumentation gives the driver a clear indication that the electrical energy storage device is not yet fully charged.

In this case, the maximum time is = 3 times the claimed battery capacity (Wh) / mains power supply (W).

- 3.1.2.5. Test procedure
- 3.1.2.5.1. The vehicle shall be started up by the means provided to the driver for normal use. The first test cycle starts on the initiation of the vehicle start-up procedure.
- 3.1.2.5.2. The test procedures described in clauses 3.1.2.5.2.1. or 3.1.2.5.2.2. of this Appendix shall be used in accordance with the Type I test procedure set out in Appendix 6 to Chapter 2.
- 3.1.2.5.2.1. Sampling shall begin (BS) before or at the initiation of the vehicle start-up procedure and end on conclusion of the final idling period of the applicable Type I test cycle (end of sampling (ES)).
- 3.1.2.5.2.2. Sampling shall begin (BS) before or at the initiation of the vehicle start-up procedure and continue over a number of repeat test cycles. It shall end on conclusion of the final idling period in the applicable Type I test cycle during which the battery reached the minimum state of charge in accordance with the following procedure (end of sampling (ES)):
  - 3.1.2.5.2.2.1. the electricity balance  $Q$  (Ah) is measured over each combined cycle according to the procedure in Appendix 1.2. to chapter 9 and used to determine when the battery minimum state of charge has been reached;
  - 3.1.2.5.2.2.2. the battery minimum state of charge is considered to have been reached in combined cycle  $N$  if the electricity balance  $Q$  measured during combined cycle  $N+1$  is not more than a 3 percent discharge, expressed as a percentage of the nominal capacity of the battery (in Ah) in its maximum state of charge, as declared by the manufacturer. At the manufacturer's request, additional test cycles may be run and their results included in the calculations in clauses 3.1.2.5.5. and 3.1.4.2 of this Appendix, provided that the electricity

balance Q for each additional test cycle shows less discharge of the battery than over the previous cycle;

- 3.1.2.5.2.2.3. after each cycle, a hot soak period of up to ten minutes is allowed. The power train shall be switched off during this period.
- 3.1.2.5.2.2.4 The weight of traction battery shall be ignored for the purpose of calculating the reference mass and inertia mass.
- 3.1.2.5.3. The vehicle shall be driven according to the provisions in Appendix 6 to chapter 2
- 3.1.2.5.4. The exhaust gases shall be analyzed according to the provisions in chapter 2.
- 3.1.2.5.5. The test results shall be compared with the limits set out in the notification and the average emission of each pollutant (expressed in mg per kilometer) for Condition A shall be calculated ( $M_{1i}$ ).

In the case of testing according to clause 3.1.2.5.2.1 of this Appendix ( $M_{1i}$ ) is the result of the specified driving cycle.

In the case of testing according to clause 3.1.2.5.2.2 of this Appendix the test result of each combined cycle run ( $M_{1ia}$ ), multiplied by the appropriate deterioration factor and  $K_i$  factors, shall be less than the limits in the notification. For the purposes of the calculation in clause 3.1.4 of this Appendix  $M_{1i}$  shall be defined as:

Equation 1:

$$M_{1i} = \frac{1}{N} \sum_{a=1}^N M_{1ia}$$

where:

$M_{1i}$ : Average emission of each pollutant

i: pollutant

N: Number of cycles

a: test cycle

3.1.3. **Condition B**

3.1.3.1. Conditioning of vehicle.

The vehicle shall be conditioned by driving the applicable Type I driving cycle as set out in Appendix 6 to chapter 2.

- 3.1.3.2. The electrical energy device / REESS of the vehicle shall be discharged while driving (on the test track, on a chassis dynamometer, etc.):
- (a) at a steady speed of 50 km/h until the fuel-consuming engine starts up, or
  - (b) if a vehicle cannot reach a steady speed of 50 km/h without the fuel-consuming engine starting up, the speed shall be reduced until it can run at a lower steady speed at which the engine does not start up for a defined time or distance (to be determined by the test agency and the manufacturer), or
  - (c) in accordance with the manufacturers' recommendation
- The fuel-consuming engine shall be stopped within ten seconds of being automatically started
- 3.1.3.3. After this preconditioning and before testing, the vehicle shall be kept in a room in which the temperature remains relatively constant between 293 K and 303 K (20 °C and 30 °C). This conditioning shall be carried out for at least six hours and continue until the temperature of the engine oil and coolant, if any, are within  $\pm 2\text{K}$  ( $\pm 2\text{ }^{\circ}\text{C}$ ) of the temperature of the room.
- 3.1.3.4. Test procedure
- 3.1.3.4.1. The vehicle shall be started up by the means provided to the driver for normal use. The first cycle starts on the initiation of the vehicle start-up procedure
  - 3.1.3.4.2. Sampling shall begin (BS) before or at the initiation of the vehicle start-up procedure and end on conclusion of the final idling period of the applicable Type I test cycle (end of sampling (ES)).
  - 3.1.3.4.3. The vehicle shall be driven according to the provisions of Appendix 6 to chapter 2.
  - 3.1.3.4.4. The exhaust gases shall be analyzed in accordance with Chapter 2
  - 3.1.3.5. The test results shall be compared with the in the Notification GSR 889I and the average emission of each pollutant for Condition B shall be calculated ( $M_{2i}$ ). The test results  $M_{2i}$ , multiplied by the appropriate deterioration and  $K_i$  factors, shall be less than the limits prescribed in the notification.
- 3.1.4. Test results

3.1.4.1. Testing in accordance with clause 3.1.2.5.2.1 of this Appendix  
 For reporting, the weighted values shall be calculated as follows  
 Equation 2:

$$M_i = \frac{(D_e \cdot M_{1i} + D_{av} \cdot M_{2i})}{D_e + D_{av}} \dots\dots\dots \text{mg/km}$$

where:

- $M_i$  = mass emission of the pollutant i in mg/km;
- $M_{1i}$  = average mass emission of the pollutant i in mg/km with a fully charged electrical energy device/REESS, calculated in accordance with clause 3.1.2.5.5 of this Appendix
- $M_{2i}$  = average mass emission of the pollutant i in mg/km with an electrical energy device/REESS in minimum state of charge (maximum discharge of capacity), calculated in accordance with clause 3.1.3.5 of this Appendix
- $D_e$  = electric range of the vehicle determined according to the procedure set out in Appendix 1.3. to Chapter 9, where the manufacturer shall provide the means for taking the measurement with the vehicle running in pure electric mode;
- $D_{av}$  = average distance between two battery recharges, as follows
  - 25 km for a vehicle with an engine capacity < 150 cm<sup>3</sup> ;
  - 25 km for a vehicle with an engine capacity ≥ 150 cm<sup>3</sup> and v max < 130 km/h;
  - 25 km for a vehicle with an engine capacity ≥ 150 cm<sup>3</sup> and v max ≥ 130 km/h.

3.1.4.2. Testing in accordance with clause 3.1.2.5.2.2 of this Appendix  
 For communication reporting, the weighted values shall be calculated as follows:

Equation 3:

$$M_i = \frac{D_{ovc}M_{1i} + D_{av}M_{2i}}{D_{ovc} + D_{av}} \text{ where:}$$

- $M_i$  = mass emission of the pollutant i in mg/km;
- $M_{1i}$  = average mass emission of the pollutant i in mg/km with a fully charged electrical energy device/REESS, calculated in accordance with clause 3.1.2.5.5 of this Appendix
- $M_{2i}$  = average mass emission of the pollutant i in mg/km with an electrical energy device/REESS in minimum state of charge (maximum discharge of capacity), calculated in accordance with clause 3.1.3.5 of this appendix
- $D_{ovc}$  = OVC range established in accordance with the procedure in Appendix 1.3. to Chapter 9;
- $D_{av}$  = average distance between two battery recharges, as follows:
  - 25 km for a vehicle with an engine capacity < 150 cm<sup>3</sup> ;
  - 25 km for a vehicle with an engine capacity ≥ 150 cm<sup>3</sup> and v max < 130 km/h;
  - 25 km for a vehicle with an engine capacity ≥ 150 cm<sup>3</sup> and v max ≥ 130 km/h.

- 3.2. **Externally chargeable vehicles (OVC HEVs) with an operating mode switch.**
- 3.2.1. Two tests shall be performed under the following conditions
- 3.2.1.1. Condition A: the test shall be carried out with a fully charged electrical energy device/REESS.
- 3.2.1.2. Condition B: the test shall be carried out with an electrical energy device/REESS in minimum state of charge (maximum discharge of capacity).
- 3.2.1.3. The operating mode switch shall be positioned in accordance with the table 2 of this Appendix

**Table 2**  
**Look-up table to determine Condition A or B depending on different hybrid vehicle concepts and on the hybrid mode selection switch position**

	- Pure electric  - Hybrid	-Pure fuel consuming - Hybrid	- Pure electric- -Pure fuel consuming - Hybrid	-Hybrid mode n <sup>(1)</sup> - Hybrid mode m <sup>1</sup>
<b>Battery state of charge</b>	<b>Switch in position</b>	<b>Switch in position</b>	<b>Switch in position</b>	<b>Switch in position</b>
<b>Condition A Fully charged</b>	Hybrid	Hybrid	Hybrid	Most electric hybrid mode <sup>(2)</sup>
<b>Condition B Min. state of charge</b>	Hybrid	Fuel-consuming	Fuel-consuming	Most fuel-consuming mode <sup>(3)</sup>

<sup>(1)</sup> For instance: sport, economic, urban, extra-urban position, etc.

<sup>(2)</sup> Most electric hybrid mode: the hybrid mode which can be proven to have the highest electricity consumption of all selectable hybrid modes when tested in accordance with condition A as per this appendix, to be established based on information provided by the manufacturer and in agreement with the test agency.

<sup>(3)</sup> Most fuel-consuming mode: the hybrid mode which can be proven to have the highest fuel consumption of all selectable hybrid modes when tested in accordance with condition B of this appendix, to be established based on information provided by the manufacturer and in agreement with the test agency.



3.2.2. **Condition A**

3.2.2.1. If the pure electric range of the vehicle is higher than one complete cycle, the Type I test may at the manufacturer's request be carried out in pure electric mode. On the request of the manufacturer, the Type I test for condition A may not be carried out.

In such cases, the value of  $M_{li}$  shall be taken as zero for calculation of final results.

3.2.2.2. The procedure shall start with the discharge of the electrical energy device/REESS of the vehicle while driving with the switch in pure electric position (on the test track, on a chassis dynamometer, etc.) at a steady speed of 70 percent  $\pm$  5 percent of the maximum design speed of the vehicle, as per IS 10278

Stopping the discharge occurs in any of the following conditions:

- (a) when the vehicle is not able to run at 65 percent of the maximum thirty minutes speed;
- (b) when the standard on-board instrumentation gives the driver an indication to stop the vehicle;
- (c) after 100 km.

If the vehicle is not equipped with a pure electric mode, the electrical energy device/REESS shall be discharged by driving the vehicle (on the test track, on a chassis dynamometer, etc.) in any of the following conditions:

- (a) at a steady speed of 50 km/h until the fuel-consuming engine of the HEV starts up;
- (b) if a vehicle cannot reach a steady speed of 50 km/h without the fuel-consuming engine starting up, the speed shall be reduced until it can run at a lower steady speed at which the fuel-consuming engine does not start up for a defined time or distance (to be determined by the test agency and the manufacturer);
- (c) in accordance with the manufacturers' recommendation

The fuel-consuming engine shall be stopped within ten seconds of being automatically started. By means of derogation if the manufacturer can prove to the test agency that the vehicle is physically not capable of achieving the thirty minutes speed the maximum fifteen minute speed may be used instead.

3.2.2.3. Conditioning of vehicle

3.2.2.4. After this preconditioning and before testing, the vehicle shall be kept in a room in which the temperature remains relatively constant between 293 K and 275 K (20 °C and 3 °C). This conditioning shall be carried out for at least six hours and continue until the temperature of the engine oil and coolant, if any, are within  $\pm 2$ K ( $\pm 2^{\circ}\text{C}$ ) of the temperature of the room, and the electrical energy device/REESS is fully charged as a result of the charging prescribed in clause 3.2.2.5 of this Appendix

3.2.2.5. During soak, the electrical energy device/REESS shall be charged with any of the following chargers

- (a) the on-board charger if fitted;
- (b) an external charger recommended by the manufacturer, using the normal overnight charging procedure.

This procedure excludes all types of special charges that could be automatically or manually initiated, e.g. equalization charges or servicing charges.

The manufacturer shall declare that a special charge procedure has not occurred during the test

- (a) End-of-charge criterion

The end-of-charge criterion corresponds to a charging time of 12 hours, except where the standard instrumentation gives the driver a clear indication that the electrical energy storage device is not yet fully charged

In this case, the maximum time is  $= 3 \times \text{claimed battery capacity (Wh)} / \text{mains power supply (W)}$ .

3.2.2.6. Test procedure

3.2.2.6.1. The vehicle shall be started up by the means provided to the driver for normal use. The first cycle starts on the initiation of the vehicle start-up procedure.

3.2.2.6.1.1. Sampling shall begin (BS) before or at the initiation of the vehicle start-up procedure and end on conclusion of the final idling period of the applicable Type I test cycle (end of sampling (ES))

3.2.2.6.1.2. Sampling shall begin (BS) before or at the initiation of the vehicle start-up procedure and continue over a number of repeat test cycles. It shall end on conclusion of the final idling period of the applicable Type I test cycle during which the battery has reached the minimum state of charge in accordance with the following procedure (end of sampling (ES))

3.2.2.6.1.2.1. The electricity balance  $Q$  (Ah) is measured over each combined cycle using the procedure in Appendix 1.2. to chapter 9 and used to determine when the battery minimum state of charge has been reached;

3.2.2.6.1.2.2. The battery minimum state of charge is considered to have been reached in combined cycle  $N$  if the electricity balance measured during combined cycle  $N+1$  is not more than a 3 percent discharge, expressed as a percentage of the nominal capacity of the battery (in Ah) in its maximum state of charge, as declared by the manufacturer. At the manufacturer's request, additional test cycles may be run and their results included in the calculations in clauses 3.2.2.7. and 3.2.4.3 of this Appendix provided that the electricity balance for each additional test cycle shows less discharge of the battery than over the previous cycle;

- 3.2.2.6.1.2.3. After each cycle, a hot soak period of up to 10 minutes is allowed. The powertrain shall be switched off during this period
- 3.2.2.6.2. The vehicle shall be driven according to the provisions of Appendix 6 to chapter 2.
- 3.2.2.6.3. The exhaust gases shall be analyzed according to Chapter 2.
- 3.2.2.7. The test results shall be compared to the emission limits as notified and the average emission of each pollutant (expressed in mg/km) for Condition A shall be calculated ( $M_{1i}$ ).
- The test result of each combined cycle run  $M_{1ia}$ , multiplied by the appropriate deterioration and  $K_i$  factors, shall be less than the emission limits as per notification. For the purposes of the calculation in clause 3.2.4 of this Appendix  $M_{1i}$  shall be calculated according to Equation 1 of this Appendix.
- 3.2.3. **Condition B**
- 3.2.3.1. Conditioning of vehicle.
- The vehicle shall be conditioned by driving the applicable Type I driving cycle set out in Appendix 6 to chapter 2.
- 3.2.3.2. The electrical energy device/REESS of the vehicle shall be discharged in accordance with clause 3.2.2.2 of this Appendix
- 3.2.3.3. After this preconditioning, and before testing, the vehicle shall be kept in a room in which the temperature remains relatively constant between 293.2K and 275.2K (20 °C and 30 °C). This conditioning shall be carried out for at least six hours and continue until the temperature of the engine oil and coolant, if any, are within  $\pm 2$ K ( $\pm 2$  °C) of the temperature of the room.
- 3.2.3.4. Test procedure
- 3.2.3.4.1. The vehicle shall be started up by the means provided to the driver for normal use. The first cycle starts on the initiation of the vehicle start-up procedure.
- 3.2.3.4.2. Sampling shall begin (BS) before or at the initiation of the vehicle start-up procedure and end on conclusion of the final idling period of the applicable Type I test cycle (end of sampling (ES)).
- 3.2.3.4.3. The vehicle shall be driven in accordance with the provisions of Appendix 6 to chapter 2.
- 3.2.3.4.4. The exhaust gases shall be analyzed in accordance with the provisions in Chapter 2.
- 3.2.3.5. The test results shall be compared with the pollutant limits in the notification G.S.R.889 and the average emission of each pollutant for Condition B shall be calculated ( $M_{2i}$ ). The test results  $M_{2i}$ , multiplied by the appropriate deterioration and  $K_i$  factors, shall be less than the notified limits.

- 3.2.4. **Test results**
- 3.2.4.1. Testing in accordance with clause 3.2.2.6.2.1 of this Appendix  
For reporting, the weighted values shall be calculated as in Equation 2 of this Appendix
- 3.2.4.2. Testing in accordance with clause 3.2.2.6.2.2 of this Appendix  
For reporting, the weighted values shall be calculated as in Equation 3 of this Appendix where:
- 3.3. **Not externally chargeable vehicles (not-OVC HEVs) without an operating mode switch**
- 3.3.1. These vehicles shall be tested according to Appendix 6 to chapter 2.
- 3.3.2. For preconditioning, at least two consecutive complete driving cycles are carried out without soak.
- 3.3.3. The vehicle shall be driven in accordance with to the provisions of Appendix 6 to chapter 2.
- 3.4. **Not externally chargeable vehicles (not-OVC HEVs) with an operating mode switch**
- 3.4.1. These vehicles are preconditioned and tested in hybrid mode in accordance with Chapter 2. If several hybrid modes are available, the test shall be carried out in the mode that is automatically set after the ignition key is turned (normal mode). On the basis of information provided by the manufacturer, the test agency shall ensure that the limit values are complied with in all hybrid modes
- 3.4.2. For preconditioning, at least two consecutive complete applicable driving cycles shall be carried out without soak.
- 3.4.3. The vehicle shall be driven in accordance with the provisions of Chapter 2.

**CHAPTER 3****TEST TYPE II REQUIREMENTS – TAILPIPE EMISSIONS AT IDLING  
AND FREE ACCELERATION****1.0 INTRODUCTION**

This Chapter describes the test procedure for Type II test and free acceleration smoke measurement applicable to compressed ignition engine.

**2.0 SCOPE**

2.1 Vehicles equipped with a propulsion type of which a positive ignition combustion engine forms a part shall be subject only to a Type II emission test as set out in clauses 3, 4 and 5 of this Chapter.

2.2 Vehicles equipped with a propulsion type of which a compression ignition combustion engine forms a part shall be subject only to a Type II free acceleration emission test as set out in clauses 3 and 6 of this Chapter. In this case clause 3.8 of this Chapter is not applicable.

**3.0 GENERAL CONDITIONS OF TYPE II EMISSION TESTING**

3.1 In general practice, Type II test shall be carried out immediately after Type I test, if not, A visual inspection of any emission control equipment shall be conducted prior to start of the Type II emission test in order to check that the vehicle is complete, in a satisfactory condition and that there are no leaks in the fuel, air supply or exhaust systems. If the testing is done immediately after the Type I test, these inspections may not be carried out.

3.2 The fuel used to conduct the Type II tests shall be the reference fuel, as specified in the notification. In case the engine is lubricated by mixing oil to the fuel, the quality and quantity of lubricating oil shall be as prescribed by the manufacturer.

3.3 During the test, the environmental temperature shall be between 293 K and 303 K (20 °C and 30 °C).

3.4 In the case of vehicles with manually-operated or semi-automatic-shift gearboxes, the test Type II test shall be carried out with the gear lever in the 'neutral' position and the clutch engaged.

3.5 In the case of vehicles with automatic-shift gearboxes, the idle Type II test shall be carried out with the gear selector in either the 'neutral' or the 'parking' position.

Where an automatic clutch is also fitted, the driven axle shall be lifted up to a point at which the wheels can rotate freely.

3.6 The Type II emission test shall be conducted immediately after the Type I emission test. In any event, if Type-II test is required to be conducted independent of Type-I test then the engine shall be warmed up to ensure the conditions as observed at the end of Type-I test.

- 3.7 The exhaust outlets shall be provided with an air-tight extension, so that the sample probe used to collect exhaust gases may be inserted at least 300 mm into the exhaust outlet without increasing the back pressure of more than 125 mm H<sub>2</sub>O and without disturbing operation of the vehicle. This extension shall be so shaped as to avoid any appreciable dilution of exhaust gases in the air at the location of the sample probe. Where a vehicle is equipped with an exhaust system with multiple outlets, either these shall be joined to a common pipe or the pollutants shall be collected from each of them and an arithmetical average taken.
- 3.8 The emission test equipment and analysers to perform the Type II testing shall be regularly calibrated and maintained. A flame ionisation detection or NDIR analyser may be used for measuring hydrocarbons.
- 3.9 The vehicles shall be tested with the fuel-consuming engine running.
- 3.9.1 For hybrid applications or applications equipped with a stop-start system, the manufacturer shall install on the vehicle a ‘service mode’ that makes it possible to inspect the vehicle for Type II tests on a running fuel-consuming engine, in order to determine its performance in relation to the data collected. Where this inspection requires a special procedure, this shall be detailed in the service manual (or equivalent media). That special procedure shall not require the use of special equipment other than that provided with the vehicle.

**4.0 TEST TYPE II – DESCRIPTION OF TEST PROCEDURE TO MEASURE TAILPIPE EMISSIONS AT IDLE AND FREE ACCELERATION**

The test shall be carried out with the engine at normal idling speed as specified by the manufacturer. The Type II idle test shall be considered acceptable if the values measured are within the applicable limits prescribed in notification.

- 4.1 **Components for adjusting the idling speed**
  - 4.1.1 Components for adjusting the idling speed for the purposes of this Chapter refer to controls for changing the idling conditions of the engine which may be easily operated by a mechanic using only the tools referred to in clause 4.1.2 of this Chapter. In particular, devices for calibrating fuel and air flows are not considered as adjustment components if their setting requires the removal of the set-stops, an operation which can normally be performed only by a Trained mechanic.
  - 4.1.2 The tools which may be used to adjust the idling speed are screwdrivers (ordinary or cross-headed), spanners (ring, open-end or adjustable), pliers, Allen keys and a generic scan tool.
- 4.2 **Determination of measurement points and Type II idle test pass/fail criteria**
  - 4.2.1 First, a measurement is taken at the setting in accordance with the conditions fixed by the manufacturer

- 4.2.2 For each adjustment component with a continuous variation, a sufficient number of characteristic positions shall be determined. The test shall be carried out with the engine at normal idling speed and at 'high idle' speed. The definition of the possible position of the adjustment components to a just 'Normal idling speed' is defined under clause 4.2.5 of this Chapter High idle engine speed is defined by the manufacturer but it must be higher than  $2500 \pm 200 \text{min}^{-1}$
- The high idle speed is reached and kept stable by manually operating the throttle pedal or throttle handle.
- 4.2.3 The measurement of the carbon monoxide content of exhaust gases shall be carried out for all the possible positions of the adjustment components, but for components with a continuous variation only for the positions referred to in clause 4.2.2 of this Chapter.
- 4.2.4 The Type II idle test shall be considered passed if the following condition is met:
- 4.2.4.1 The maximum pollutant content shall not exceed the notified limits.
- 4.2.5 The possible positions of the adjustment components shall be limited by any of the following:
- 4.2.5.1 the larger of the following two values:
- the lowest idling speed which the engine can reach;
  - the speed recommended by the manufacturer, minus 100 revolutions per minute;
- 4.2.5.2 the smallest of the following three values:
- the highest rotation speed which the crankshaft of the engine can attain by activation of the idling speed components;
  - the rotation speed recommended by the manufacturer, plus 250 revolutions per minute;
  - the cut-in rotation speed of automatic clutches
- 4.2.6 Settings incompatible with the correct running of the engine shall not be adopted as measurement settings. In particular, if the engine is equipped with several carburettors, all the carburettors shall have the same setting.
- 4.3 **The following parameters shall be measured and recorded at normal idling speed and high idle Speed as per notification:**
- The carbon monoxide (CO) content by volume of the exhaust gases emitted (in vol percent);
  - The carbon dioxide (CO<sub>2</sub>) content by volume of the exhaust gases emitted (in vol percent);
  - hydrocarbons (HC) in ppm(n-hexane);
  - the oxygen (O<sub>2</sub>) content by volume of the exhaust gases emitted (in vol percent) or lambda, as chosen by the manufacturer;
  - the engine speed during the test, including any tolerances;
  - the engine oil temperature at the time of the test. Alternatively, for liquid cooled engines, the coolant temperature shall be acceptable.

- 4.3.1 With respect to the parameters under clause 4.3. (d) of this Chapter (O<sub>2</sub>/lambda) the following shall apply
  - 4.3.1.1 The measurement shall only be conducted at high idle engine speed;
  - 4.3.1.2 Vehicles in the scope of this measurement are only those equipped with a closed loop fuel system
  - 4.3.1.3 Exemptions for vehicle with:
    - 4.3.1.3.1 Engines equipped with a mechanically-controlled (spring, vacuum) secondary air system;
    - 4.3.1.3.2 Two – stroke engines operated on a mix of fuel and lubrication oil.

**5.0 CO CONCENTRATION CALCULATION IN THE TYPE II IDLE TEST**

The sampling probe shall be inserted into the exhaust pipe to a depth of at least 300 mm into the pipe connecting the exhaust with the sampling bag and as close as possible to the exhaust.

- 5.1 The CO (C<sub>CO</sub>) and CO<sub>2</sub> (C<sub>CO<sub>2</sub></sub>) concentration shall be determined from the measuring instrument readings or recordings, by use of appropriate calibration curves.
- 5.2 The corrected concentration for carbon monoxide is:  
Equation 1: For four stroke engine:

$$C_{CO_{corr}} = 15 \times \frac{C_{CO}}{C_{CO} + C_{CO_2}}$$

Equation 2: For two stroke engine:

$$C_{CO_{corr}} = 10 \times \frac{C_{CO}}{C_{CO} + C_{CO_2}}$$

- 5.3 The C<sub>CO</sub> concentration (see clause 5.1. of this Chapter) shall be measured in accordance with the formulae in clause 5.2 and does not need to be corrected if the total of the concentrations measured (C<sub>CO</sub> + C<sub>CO<sub>2</sub></sub>) is at least:
  - For petrol(E5): 15 percent;
  - a. For LPG: 13.5percent;
  - b. For NG/bio methane: 11.5 percent.

**6.0 TEST TYPE II – FREE ACCELERATION TEST PROCEDURE**

- 6.1 The combustion engine and any turbocharger or supercharger, if fitted, shall be running at idle before start of each free acceleration test cycle.
- 6.2 To initiate each free acceleration cycle, the throttle pedal/accelerator shall be applied gradually but not violently to reach full throttle operating condition within 5 seconds, so as to obtain maximum delivery from the fuel pump.



- 6.3 During each free acceleration cycle, the engine shall reach cut-off speed or, for vehicles with automatic transmissions, the speed specified by the manufacturer or, if this data is not available, two-thirds of the cut-off speed, before the throttle is released. This could be checked, for instance, by monitoring engine speed or by allowing at least two seconds elapsing between initial throttle depression and release.
- 6.4 For vehicles equipped with CVT and automatic clutch, the driven wheels may be lifted from the ground. For engines with safety limits in the engine control (e.g. max 1500 rpm without running wheels or without gear engaged), this maximum engine speed shall be reached.
- 6.5 The average concentration level of the opacity (in  $\text{m}^{-1}$ ) in the exhaust flow (opacity) shall be measured during five free acceleration tests. Opacity means an optical measurement of the density of particulate matter in the exhaust flow of an engine, expressed in  $\text{m}^{-1}$ . Time duration between the two consecutive free accelerations tests shall be 5 to 20 seconds
- 7.0 TEST TYPE II – FREE ACCELERATION TEST RESULTS AND REQUIREMENTS**
- 7.1 The test value measured in accordance with clause 6.5 of this Chapter shall be in compliance with the requirements laid down in CMV Rule No. 115 (2).
- 8.0 COP PROCEDURE – TECHNICAL REQUIREMENTS**
- 8.1 COP test procedure for Type II test shall be as per clause 6.0 and 7.0 of Appendix 10 to Chapter 2.

**CHAPTER 4**  
**TYPE III TESTS – EMISSIONS OF CRANKCASE GASES AND**  
**TYPE IV TESTS – EVAPORATIVE EMISSIONS**

**1.0 PURPOSE**

This Chapter provides the test methods for the determination of crankcase gas emissions (Test Type III).

This Chapter also provides test procedures to determine evaporative emissions (Test Type IV) owing to evaporation of fuel through the vehicle's fuel tank and fuel delivery system.

**2.0 SCOPE AND APPLICATION**

2.1 Three-wheeled Vehicles of L5 category covered in the scope with regard to the propulsion unit and fuel type in accordance with notification.

3.0 For Definitions refer overall requirements.

4.0 **LIST OF ACRONYMS AND SYMBOLS:** refer Appendix 1 Chapter 2

**5.0 GENERAL REQUIREMENTS**

5.1 Vehicles, systems, and components shall be so designed, constructed and assembled by the manufacturer, so as to enable the vehicle, in normal use and maintained according to the prescriptions of the manufacturer, to comply with the provisions of this Chapter during its useful life.

**6.0 TEST TYPE III REQUIREMENTS: EMISSIONS OF CRANKCASE GASES****6.1 Introduction**

6.1.1 Test Type III shall be conducted in order to demonstrate that zero emissions from the crankcase and/or if applicable the crankcase ventilation system cannot escape directly into the atmosphere.

**6.2 General provisions**

6.2.1 Zero emissions from the crankcase and/or if applicable the crankcase ventilation system may not escape directly into the atmosphere from any vehicle throughout its useful life. For this purpose it may require:

6.2.1.1 A written declaration from the vehicle manufacturer that the propulsion unit is equipped with a closed crankcase system preventing crankcase gas to be discharged directly into the ambient atmosphere.

6.2.2 The manufacturer shall provide the test agency with technical details and drawings to prove that the engine or engines are so constructed as to prevent vapour of any fuel, lubrication oil or crankcase gases from escaping to the atmosphere from the crankcase gas ventilation system.

6.2.3 A physical verification may be conducted that the crankcase breather is not let out into atmosphere but is connected to the Intake system.

6.2.4 Type III test is not applicable for vehicles equipped with a two-stroke engine containing a scavenging port between the crank case and the cylinder(s).

**7.0 TEST TYPE IV REQUIREMENTS: EVAPORATIVE EMISSIONS**

**7.1. Introduction – evaporative emissions**

7.1.1 The procedure laid down in Appendix 1 of this chapter sets out the evaporative hydrocarbon emission determination requirements of the whole vehicle.

**7.2. Test fuel**

The appropriate test fuel, as defined in notification shall be used.

7.2.1 If the combustion engine uses a petrol-lubrication oil mixture, the lubrication oil added to the reference fuel shall comply with the grade and quantity recommended by the manufacturer.

**7.3 Documentation**

The vehicle manufacturer shall fill out the information in accordance with the evaporative emission test parameters laid down in AIS-007 and submit it to the test agency.

**APPENDIX 1 TO CHAPTER 4  
SEALED HOUSING FOR EVAPORATION DETERMINATION  
(SHED TEST PROCEDURE)**

**1.0 DESCRIPTION OF SHED TEST**

The evaporative emission SHED test (Figure 1 of this Appendix) consists of a conditioning phase and a test phase, as follows:

- (a) conditioning phase:
  - (i) driving cycle;
  - (ii) vehicle soak;
- (b) test phase:
  - (i) diurnal (breathing loss) test;
  - (ii) driving cycle;
  - (iii) hot soak loss test.

Mass emissions of hydrocarbons from the tank breathing loss and the hot soak loss phases are added together to provide an overall result for the test.

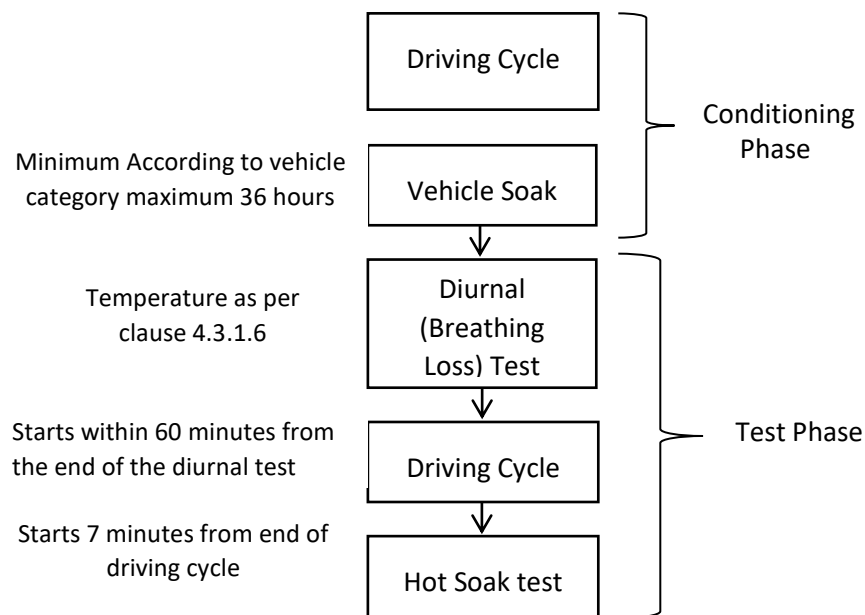

**Figure 1  
Flow Chart – SHED test procedure**

**2.0 TEST VEHICLE REQUIREMENT**

**2.1. Durability**

The SHED test shall be conducted at the choice of the manufacturer with one or more degreened test vehicle(s) equipped with

- 2.1.1 The ageing of the canister(s) has to be verified. This may be done by demonstrating that it has accumulated a minimum of 1000 km. If this demonstration is not given, Procedure prescribed in Appendix 2 of this chapter shall be used. In the case of a multiple canister system each canister must undergo the procedure separately.

2.1.2 Aged evaporative emission control devices. The ageing test procedure set-out in Appendix 2 shall apply.

**2.2. Test vehicles**

The degreened test vehicle, which shall be representative of the vehicle type with regard to environmental performance to be approved, shall be in good mechanical condition and, before the evaporative test, have been run in and driven at least 1000 km after first start on the production line. The evaporative emission control system shall be connected and functioning correctly over this period and the carbon canister<sup>1</sup> and evaporative emission control valve subjected to normal use, undergoing neither abnormal purging nor abnormal loading.

<sup>(1)</sup> Or the canister with HC absorbent material or other equivalent.

2.2.1 RESERVED

**3.0 CHASSIS DYNAMOMETER AND EVAPORATIVE EMISSIONS ENCLOSURE**

3.1. The chassis dynamometer shall meet the requirements of Appendix 3 to Chapter 2 provided that the chassis dynamometer shall be capable of accommodating three-wheeled vehicles (e.g. two rollers, long single roller)

**3.2. Evaporative emission measurement enclosure (SHED)**

The evaporative emission measurement enclosure shall be a gas-tight rectangular measuring chamber able to contain the vehicle under test. The vehicle shall be accessible from all sides when inside and the enclosure when sealed shall be gas-tight. The inner surface of the enclosure shall be impermeable to hydrocarbons. At least one of the surfaces shall incorporate a flexible impermeable material or other device to allow the equilibration of pressure changes resulting from small changes in temperature. Wall design shall be such as to promote good dissipation of heat.

**3.3. Analytical systems**

**3.3.1. Hydrocarbon analyzer**

3.3.1.1. The atmosphere within the chamber is monitored using a hydrocarbon detector of the flame ionization detector (FID) type. Sample gas shall be drawn from the midpoint of one side wall or the roof of the chamber and any bypass flow shall be returned to the enclosure, preferably to a point immediately downstream of the mixing fan.

3.3.1.2. The hydrocarbon analyzer shall have a response time to 90percent of final reading of less than 1.5 seconds. Its stability shall be better than 2 percent of full scale at zero and at 80percent  $\pm$  20percent of full scale over a 15-minute period for all operational ranges.

3.3.1.3. The repeatability of the analyzer expressed as one standard deviation shall be better than 1 percent of full scale deflection at zero and at 80percent  $\pm$  20percent of full scale on all ranges used.

- 3.3.1.4. The operational ranges of the analyzer shall be chosen to give best resolution over the measurement, calibration and leak-checking procedures.
- 3.3.2. Hydrocarbon analyzer data recording system
- 3.3.2.1. The hydrocarbon analyzer shall be fitted with a device to record electrical signal output either by strip chart recorder or other data-processing system at a frequency of at least once per minute. The recording system shall have operating characteristics at least equivalent to the signal being recorded and shall provide a permanent record of results. The record shall show a positive indication of the beginning and end of the fuel tank heating and hot soak periods together with the time elapsed between start and completion of each test.
- 3.4. **Fuel tank heating**
- 3.4.1. The fuel tank heating system shall consist of at least two separate heat sources with two temperature controllers. A typical heat source shall be a pair of heating pads. Other heat sources may be used as required by the circumstances at the request of the manufacturer to the satisfaction of the test agency. Temperature controllers may be manual, such as variable transformers, or they may be automated. Since vapour and fuel temperature are to be controlled separately, an automatic controller is recommended both for the fuel and the vapour.
- 3.4.2. The heating system shall not cause hot-spots on the wetted surface of the tank which would cause local overheating of the fuel. Heating pads, for the fuel if used, shall be located as low as practicable on the fuel tank and shall cover at least 10 percent of the wetted surface. The centre line of the fuel heating strips if used, shall be below 30percent of the fuel depth as measured from the bottom of the fuel tank, and approximately parallel to the fuel level in the tank. The centre line of the vapour heating strips, if used, shall be located at the approximate height of the centre of the vapour volume. The temperature controllers shall be capable of controlling the fuel and vapour temperatures to the heating function laid down in clause 4.3.1.6 of this Appendix
- 3.4.3. In order to ensure uniform and appropriate heating and measurement of temperature for fuel and vapour the following precautions or the manufacturer recommendations shall be followed:
- I. Separate heating pads for fuel and vapour shall cover as much area as possible;
  - II. The pasting of heating pads on either side of fuel tank shall be symmetric for fuel and vapour heating;
  - III. The position of fuel and vapour temperature sensors shall be as close to the area covered by heating pads respectively;
  - IV. No fuel heating pad shall be located above a 40 percent volume fill line from bottom. Likewise no vapour heating pad for the tank evaporative test shall be below the 60 percent volume fill line from bottom.

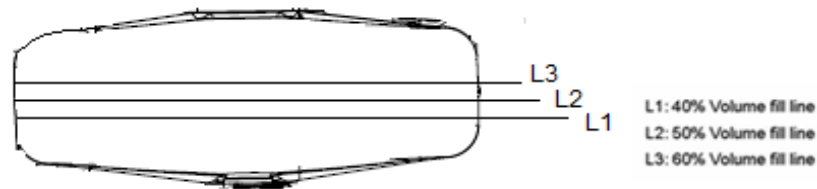

**Figure 2**

**Example fuel tank with appropriate positioning of fuel tank heating pads to control fuel and vapour temperatures.**

- 3.4.4 With temperature sensors positioned as in clause 3.5.2 of this Appendix, the fuel heating device shall make it possible to evenly heat the fuel and fuel vapour in the tank in accordance with the heating function described in 4.3.1.6 of this Appendix. The heating system shall be capable of controlling the fuel and vapour temperatures to  $\pm 1.7\text{K}$  ( $\pm 1.7\text{ }^\circ\text{C}$ ) of the required temperature during the tank heating process.
- 3.4.5 Notwithstanding the requirements of clause 3.4.2 of this Appendix if a manufacturer is unable to meet the heating requirement specified, due to use of thick-walled plastic fuel tanks for example, then the closest possible alternative heat slope shall be used. Prior to the commencement of any test, manufacturers shall submit engineering data to the test agency to support the use of an alternative heat slope.
- 3.5. **Temperature recording**
- 3.5.1. The temperature in the chamber is recorded at 2 points by temperature sensors which are connected so as to show a mean value. The measuring points are extended approximately 0.1 m into the enclosure from the vertical centre line of each side wall at a height of  $0.9 \pm 0.2$  m.
- 3.5.2. The temperatures of the fuel and fuel vapour shall be recorded by means of sensors positioned in the fuel tank so as to measure the temperature of the prescribed test fuel at the approximate mid-volume of the fuel. In addition, the vapour temperature in the fuel tank shall be measured at the approximate mid-volume of the vapour.
- 3.5.3 When the fuel or vapour temperature sensors cannot be located in the fuel tank to measure the temperature of the prescribed test fuel or vapour at the approximate mid-volume, sensors shall be located at the approximate mid-volume of each fuel or vapour containing cavity. The average of the readings from these sensors shall constitute the fuel or vapour temperature. The fuel and vapour temperature sensors shall be located at least one inch away from any heated tank surface. The test agency may approve alternate sensor locations where the specifications above cannot be met or where tank symmetry provides redundant measurements.
- 3.5.4 Throughout the evaporative emission measurements, temperatures shall be recorded or entered into a data processing system at a frequency of at least once per minute.

- 3.5.5 The accuracy of the temperature recording system shall be within  $\pm 1.7$  °C and capable of resolving temperatures to 293.8K (20.5 °C).
- 3.5.6 The recording or data processing system shall be capable of resolving time to  $\pm 15$  seconds.
- 3.6. **Fans**
- 3.6.1. It shall be possible to reduce the hydrocarbon concentration in the chamber to the ambient hydrocarbon level by using one or more fans or blowers with the SHED door(s) open.
- 3.6.2. The chamber shall have one or more fans or blowers of likely capacity 0.1 to 0.5 m<sup>3</sup>/s with which it is possible to thoroughly mix the atmosphere in the enclosure. It shall be possible to attain an even temperature and hydrocarbon concentration in the chamber during measurements. The vehicle in the enclosure shall not be subjected to a direct stream of air from the fans or blowers.
- 3.7. **Gases**
- 3.7.1. The following pure gases shall be available for calibration and operation:
- A) purified synthetic air (purity: < 1 ppm C1 equivalent <1 ppm CO, < 400 ppm CO<sub>2</sub>, 0.1 ppm NO); oxygen content between 18 and 21 percent by volume;
  - B) hydrocarbon analyzer fuel gas (40  $\pm$  2 percent hydrogen, and balance helium with less than 1 ppm C1 equivalent hydrocarbon, less than 400 ppm CO<sub>2</sub>);
  - C) propane (C<sub>3</sub>H<sub>8</sub>), 99.5 percent minimum purity.
- 3.7.2. Calibration and span gases shall be available containing mixtures of propane (C<sub>3</sub>H<sub>8</sub>) and purified synthetic air. The true concentrations of a calibration gas shall be within  $\pm 2$ percent of the stated figures. The accuracy of the diluted gases obtained when using a gas divider shall be to within  $\pm 2$ percent of the true value. The concentrations specified in clause 3.7.1 of this Appendix may also be obtained by the use of a gas divider using synthetic air as the diluting gas. The FID analyzer shall be calibrated using air/propane or air/hexane mixtures with nominal hydrocarbon concentrations equal to 50 percent and 90 percent of full scale.
- 3.8. **Additional equipment**
- 3.8.1. The relative humidity in the test area shall be measurable to within  $\pm 5$  percent.
- 3.8.2. The pressure within the test area shall be measurable to within  $\pm 0.1$  kPa.
- 3.9. **Alternative equipment**
- 3.9.1. At the request of the manufacturer and with the agreement of the test agency, the test agency may authorize the use of alternative equipment provided that it can be demonstrated that it gives equivalent results.



**4.0 TEST PROCEDURE**

**4.1. Test preparation**

- 4.1.1. The vehicle is mechanically prepared before the test as follows:
- a) the exhaust system of the vehicle shall not exhibit any leaks;
  - b) the vehicle may be steam-cleaned before the test;
  - c) the fuel tank of the vehicle shall be equipped with temperature sensors so that the temperature of the fuel and fuel vapour in the fuel tank can be measured when it is filled to 50 percent  $\pm$  2 percent of its capacity declared by the manufacturer;
  - d) additional fittings, adaptors or devices may optionally be fitted to allow a complete draining of the fuel tank. Alternatively, the fuel tank may be evacuated by means of a pump or siphon that prevents fuel spillage.

**4.2. Conditioning phase**

- 4.2.1. The vehicle shall be taken into the test area where the ambient temperature is between 293 K and 303 K (20 °C and 30 °C).
- 4.2.2. Before switching off the engine, the test vehicle is placed on a chassis dynamometer and driven a single time through the applicable Type I test cycle as specified in Appendix 6 to Chapter 2.
- 4.2.3. The vehicle is parked in the test area for the minimum period stated in Table 1 of this Appendix of this Chapter.

**Table 1  
SHED test – minimum and maximum soak periods**

<b>Engine capacity</b>	<b>Minimum (hours)</b>	<b>Maximum (hours)</b>
< 170 cm <sup>3</sup>	6	36
170 cm <sup>3</sup> $\leq$ engine capacity < 280 cm <sup>3</sup>	8	36
$\geq$ 280 cm <sup>3</sup>	12	36

**4.3. Test phases**

**4.3.1. Tank breathing (diurnal) evaporative emission test**

- 4.3.1.1. The measuring chamber shall be vented/purged for several minutes immediately before the test until a stable background is obtainable. The chamber mixing fan(s) shall be switched on at this time also.
- 4.3.1.2. The hydrocarbon analyzer shall be set to zero and spanned immediately before the test.
- 4.3.1.3. The fuel tank(s) shall be emptied as described in clause 4.1.1 and refilled with test fuel at a temperature of between 283 K and 287K (10 °C and 14 °C) to 50 percent  $\pm$  2percent of the capacity declared by the manufacturer.

- 4.3.1.4. The test vehicle shall be brought into the test enclosure with the engine switched off and parked in an upright position. The fuel tank sensors and heating device shall be connected, if necessary. Immediately begin recording the fuel temperature and the air temperature in the enclosure. If a venting/purging fan is still operating, it shall be switched off at this time.
- 4.3.1.5. The fuel and vapour may be artificially heated to the starting temperatures of 289 K (16°C) and 294 K (21°C) ± 1K (±1°C) respectively. An initial vapour temperature up to 5 °C above 21°C may be used. For this condition, the vapour shall not be heated at the beginning of the diurnal test. When the fuel temperature has been raised to 278.7K (5.5°C) below the vapour temperature by following the  $T_f$  function, the remainder of the vapour heating profile shall be followed.
- 4.3.1.6. As soon as the fuel temperature reaches 14°C:
- (1) Install the fuel filler cap(s);
  - (2) Turn off the purge blowers, if not already off at that time;
  - (3) Close and seal enclosure doors.
- 4.3.1.6.1 As soon as the fuel reaches a temperature of 16°C ± 1 °C the test procedure shall continue as follows:
- a) the hydrocarbon concentration, barometric pressure and the temperature shall be measured to give the initial readings  $C_{HC}$ ,  $i$ ,  $p_i$  and  $T_i$  for the tank heat build test;
  - b) a linear heat build of 13.8K or 20 ± 0.5 K over a period of 60 ± 2 minutes shall begin. The temperature of the fuel and fuel vapour during the heating shall conform to the function below to within ± 1.7°C, or the closest possible function as described in 3.4.3:
- 4.3.1.6.2 For exposed type fuel tanks:
- Equation 1 :
- $$T_f = 0.3333 *t + 288.5 \text{ K}$$
- $$T_v = 0.3333 *t + 294 \text{ K}$$
- 4.3.1.6.3 For non-exposed type fuel tanks:
- Equation 2:
- $$T_f = 0.2222 *t + 288.5 \text{ K}$$
- $$T_v = 0.2222 *t + 294 \text{ K}$$
- where:
- $T_f$  = required temperature of fuel (K);
- $T_v$  = required temperature of vapour (K);
- $t$  = time from start of the tank heat build in minutes.
- 4.3.1.7 The hydrocarbon analyzer is set to zero and spanned immediately before the end of the test.

- 4.3.1.8. If the heating requirements in clause 4.3.1.6 of this Appendix have been met over the  $60 \pm 2$  minute period of the test, the final hydrocarbon concentration in the enclosure is measured ( $C_{HC,f}$ ). The time or elapsed time of this measurement is recorded, together with the final temperature and barometric pressure  $T_f$  and  $p_f$ .
- 4.3.1.9. The heat source is turned off and the enclosure door unsealed and opened. The heating device and temperature sensor are disconnected from the enclosure apparatus. The vehicle is now removed from the enclosure with the engine switched off.
- 4.3.1.10. To prevent abnormal loading of the carbon canister, fuel tank caps may be removed from the vehicle during the period between the end of the diurnal test phase and the start of the driving cycle. The driving cycle shall begin within 60 minutes of the completion of the breathing loss test.
- 4.3.2. **Driving cycle**
- 4.3.2.1. Following the tank breathing losses test, the vehicle is pushed or otherwise maneuvered on to the chassis dynamometer with the engine switched off. It is then driven through the driving cycle specified in Appendix 6 to **Chapter 2**.
- 4.3.3. **Hot soak evaporative emissions test**
- The level of evaporative emissions is determined by the measurement of hydrocarbon emissions over a 60-minute hot soak period. The hot soak test shall begin within seven minutes of the completion of the driving cycle specified in clause 4.2 of this Appendix and within two minutes of engine shutdown.
- 4.3.3.1. Before the completion of the test run, the measuring chamber shall be purged for several minutes until a stable hydrocarbon background is obtained. The enclosure mixing fan(s) shall also be turned on at this time.
- 4.3.3.2. The hydrocarbon analyzer shall be set to zero and spanned immediately prior to the test.
- 4.3.3.3. The vehicle shall be pushed or otherwise moved into the measuring chamber with the engine switched off.
- 4.3.3.4. The enclosure doors are closed and sealed gas-tight within seven minutes of the end of the driving cycle.
- 4.3.3.5. A  $60 \pm 0.5$  minute hot soak period begins when the chamber is sealed. The hydrocarbon concentration, temperature and barometric pressure are measured to give the initial readings  $C_{HC, i}$ ,  $p_i$  and  $T_i$  for the hot soak test. These figures are used in the evaporative emission calculation laid down in clause 5 of this Appendix.
- 4.3.3.6. The hydrocarbon analyzer shall be zeroed and spanned immediately before the end of the  $60 \pm 0.5$  minute test period.

4.3.3.7. At the end of the  $60 \pm 0.5$  minute test period, measure the hydrocarbon concentration in the chamber. The temperature and the barometric pressure are also measured. These are the final readings  $C_{HC}$ ,  $f$ ,  $p_f$  and  $T_f$  for the hot soak test used for the calculation in clause 5 of this Appendix. This completes the evaporative emission test procedure.

4.4. **Alternative test procedures**

4.4.1. At the request of the manufacturer to the satisfaction of the test agency, alternative methods may be used to demonstrate compliance with the requirements of this Appendix. In such cases, the manufacturer shall satisfy the test agency that the results from the alternative test can be correlated with those resulting from the procedure described in this Appendix. This correlation shall be documented and added to the information folder.

**5.0 CALCULATION OF RESULTS**

5.1. The evaporative emission tests described in clause 4 allow the hydrocarbon emissions from the tank breathing and hot soak phases to be calculated. Evaporative losses from each of these phases is calculated using the initial and final hydrocarbon concentrations, temperatures and pressures in the enclosure, together with the net enclosure volume.

The formula below is used:

Equation 3:

$$m_{HC} = k * V * 10^{-4} 8 \left( \frac{C_{HCf} * p_f}{T_f} - \frac{C_{HCi} * p_f}{T_i} \right)$$

where:

$m_{HC}$  = mass of hydrocarbon emitted over the test phase (grams);

$C_{HC}$  = hydrocarbon concentration measured in the enclosure (ppm (volume) C<sub>1</sub> equivalent);

$V$  = net enclosure volume in cubic metres corrected for the volume of the vehicle. If the volume of the vehicle is not determined, a volume of 0.25 m<sup>3</sup> shall be subtracted;

$T$  = ambient chamber temperature, K;

$P$  = barometric pressure in kPa;

H/C = hydrogen to carbon ratio;

$k$  = 1.2 (12 + H/C);

where:

$i$  is the initial reading;

$f$  is the final reading;

H/C is taken to be 2.33 for tank breathing losses;

H/C is taken to be 2.20 for hot soak losses.

**5.2. Overall results of test**

The overall evaporative hydrocarbon mass emission for the vehicle is taken to be:

Equation 4:

$$m_{\text{total}} = m_{\text{TH}} + m_{\text{HS}}$$

where:

$m_{\text{total}}$  = overall evaporative mass emissions of the vehicle (grams);

$m_{\text{TH}}$  = evaporative hydrocarbon mass emission for the tank heat build (grams);

$m_{\text{HS}}$  = evaporative hydrocarbon mass emission for the hot soak (grams).

**6.0 TEST LIMIT VALUES**

When tested according to this Appendix, overall evaporative total hydrocarbon mass emission for the vehicle ( $m_{\text{total}}$ ) shall not exceed the limit values as specified in the notification.

**APPENDIX 1.1 TO CHAPTER 4**  
**PRECONDITIONING REQUIREMENTS FOR A HYBRID APPLICATION**  
**BEFORE START OF THE SHED TEST**

**1.0 SCOPE**

- 1.1. The following preconditioning requirements before starting the SHED test shall apply only to L5-category vehicles equipped with a hybrid propulsion.

**2.0 TEST METHODS**

- 2.1. Before starting the SHED test procedure, the test vehicles shall be preconditioned as follows:

## 2.1.1. OVC vehicles.

- 2.1.1.1. As regards OVC vehicles without an operating mode switch, the procedure shall start with the discharge of the electrical energy device / REESS of the vehicle while driving (on the test track, on a chassis dynamometer, etc.) in any of the following conditions:

- (a) at a steady speed of 50 km/h until the fuel-consuming engine of the HEV starts up;
- (b) if a vehicle cannot reach a steady speed of 50 km/h without the fuel-consuming engine starting up, the speed shall be reduced until it can run at a lower steady speed at which the fuel-consuming engine does not start up for a defined time or distance (to be determined by the and the manufacturer);
- (c) in accordance with the manufacturer's recommendation.

The fuel-consuming engine shall be stopped within ten seconds of being automatically started.

- 2.1.1.2. As regards OVC vehicles with an operating mode switch, the procedure shall start with the discharge of the electrical energy device / REESS of the vehicle while driving with the switch in pure electric position (on the test track, on a chassis dynamometer, etc.) at a steady speed of 70 percent  $\pm$  5 percent from the maximum thirty minutes speed of the vehicle. By means of derogation if the manufacturer can prove to the test agency to the satisfaction of the Test Agency that the vehicle is physically not capable of achieving the thirty minutes speed the maximum fifteen-minute speed may be used instead.

Stopping the discharge occurs in any of the following conditions:

- (a) when the vehicle is not able to run at 65 percent of the maximum thirty minutes speed;
- (b) when the standard on-board instrumentation gives the driver an indication to stop the vehicle;
- (c) after 100 km.

If the vehicle is not equipped with a pure electric mode, the electrical energy device / REESS discharge shall be conducted with the vehicle driving (on the test track, on a chassis dynamometer, etc.) under any of the following conditions:

- a) at a steady speed of 50 km/h until the fuel-consuming engine of the HEV starts up;
- b) if a vehicle cannot reach a steady speed of 50 km/h without the fuel-consuming engine starting up, the speed shall be reduced until it can run at a lower steady speed at which the fuel-consuming engine does not start up for a defined time or distance (to be determined by the test agency and the manufacturer);
- c) in accordance with the manufacturer's recommendation.

The engine shall be stopped within ten seconds of being automatically started. By means of derogation if the manufacturer can prove to the test agency to the satisfaction of the Test Agency that the vehicle is physically not capable of achieving the thirty minutes speed the maximum fifteen-minute speed may be used instead.

2.1.2. NOVC vehicles.

2.1.2.1. As regards NOVC vehicles without an operating mode switch, the procedure shall start with a preconditioning of at least two consecutive complete, applicable test Type I driving cycles without soak.

2.1.2.2. As regards NOVC vehicles with an operating mode switch, the procedure shall start with a preconditioning of at least two consecutive complete, applicable driving cycles without soak, with the vehicle running in hybrid mode. If several hybrid modes are available, the test shall be carried out in the mode which is automatically set after the ignition key is turned (normal mode). On the basis of information provided by the manufacturer, the test agency shall ensure that the limit values are complied with in all hybrid modes.

2.1.3. The preconditioning drive shall be carried out according to the Type I test cycle in Appendix 6 to Chapter 2.

2.1.3.1. For OVC vehicles this shall be carried out under the same conditions as specified by Condition B of the Type I test in Appendix 11 to Chapter 2.

2.1.3.2. For NOVC vehicles this shall be carried out under the same conditions as in the Type I test.

**APPENDIX 2 TO CHAPTER 4**

**(A) AGEING TEST PROCEDURES FOR EVAPORATIVE EMISSION CONTROL DEVICES**

**1.0 TEST METHODS FOR AGEING OF EVAPORATIVE EMISSION CONTROL DEVICES**

The SHED test shall be conducted with aged evaporative emission control devices fitted. The ageing tests for those devices shall be conducted according to the procedures in this Appendix.

**2.0 CARBON CANISTER AGEING**

A carbon canister representative of the propulsion family as set out in Chapter 8 shall be selected as test canister. Canister aging shall be conducted at the choice of manufacturer by the carbon canister aging procedure A or B.

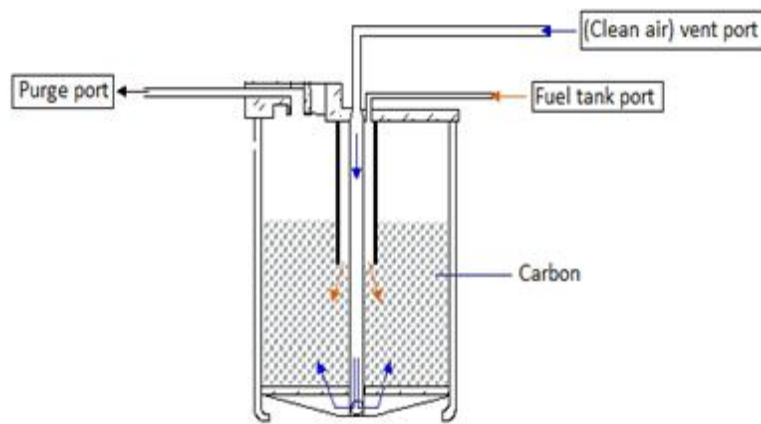

**Figure 1  
Carbon canister gas flow diagram and ports**

**2.1. Canister ageing test procedure A**

In the case of a multiple carbon canister system, each carbon canister shall undergo the procedure separately. The number of test cycles of carbon canister loading and discharging shall correspond to the number set out in Table 1 of this Appendix.

**Table 1  
Vehicle classification and the required number of loading and discharging of the carbon canister for rapid ageing.**

Vehicle classification	Number of cycles
$v_{max} \leq 50 \text{ km/h}$	90
$50\text{km/h} < v_{max} < 130 \text{ km/h}$	170
$v_{max} \geq 130 \text{ km/h}$	300

The dwell time and subsequent purging of fuel vapour shall be run to age the test carbon canister at an ambient temperature of  $297 \text{ K} \pm 275 \text{ K}$  ( $24 \text{ }^\circ\text{C} \pm 2 \text{ }^\circ\text{C}$ ) as follows:



- 2.1.1. **Canister loading part of the test cycle**
- 2.1.1.1. Loading of the carbon canister shall start within one minute of completing the purge portion of the test cycle.
- 2.1.1.2. The (clean air) vent port of the carbon canister shall be open and the purge port shall be capped. A mix by volume of 50 percent air and 50 percent commercially available petrol or reference fuel shall enter through the tank port of the test carbon canister at a flow rate of 40 grams/hour. The petrol vapour shall be generated at a petrol temperature of  $313.2\text{K} \pm 2\text{K}$  ( $40 \pm 2$  °C).
- 2.1.1.3. The test carbon canister shall be loaded each time to 2000 mg or more breakthrough detected by:
- 2.1.1.3.1. FID analyzer reading (using a mini-SHED or similar) or 5000 ppm instantaneous reading on the FID occurring at the (clean air) vent port; or
- 2.1.1.3.2. Gravimetric test method using the difference in mass of the test carbon canister charged to 2000 mg or more break through and the purged carbon canister. In this case the test equipment shall be capable of measuring the mass with a minimum accuracy in the range between 0 and +100 mg.
- 2.1.2. **Dwell time**
- 2.1.2.1. A five minute dwell period between carbon canister loading and purging as part of the test cycle shall be applied.
- 2.1.3. **Canister purging part of the test cycle**
- 2.1.3.1. The test carbon canister shall be purged through the purge port and the tank port shall be capped.
- 2.1.3.2. Four hundred carbon canister bed volumes shall be purged at a rate of 24 l/min into the vent port.
- 2.2. **Canister ageing test procedure B**
- 2.2.1. A test cycle will include loading the HC storing components with gasoline vapours up to 80 percent by weight of its maximum storing capacity followed by 10 minutes waiting with the system intake port sealed. Then purge shall start using a flow rate of  $28.3 \pm 5.5$  l/min at  $293.2\text{K} \pm 5\text{K}$  ( $20^\circ\text{C} \pm 5^\circ\text{C}$ ) for 7.5 minutes
- 2.2.2. The method to be used to load the storing components consists of heating a container filled with a pre-measured quantity of petrol up to  $353.2\text{K}$  ( $80^\circ\text{C}$ ). At  $353.2\text{K}$  ( $80^\circ\text{C}$ ) approximately one third of the petrol will evaporate. The evaporated petrol shall be equivalent to 80 percent (by weight) of the HC storing capacity of the HC storing components. The petrol vapours are allowed to enter through the intake of the storing components.
- 2.2.3. The number of test cycles of carbon canister loading and purging shall correspond to the number set out in Table 1 of this Appendix 2A of this Chapter.

## APPENDIX 2 TO CHAPTER 4

**B) ALTERNATE AGEING TEST PROCEDURES FOR  
EVAPORATIVE EMISSION CONTROL DEVICES**

- 1.0 Alternate canister ageing procedure may be used. In the case of a multiple canister system each canister must undergo the procedure separately
- 1.1 The canister is removed from the vehicle. Special care must be taken during this step to avoid damage to components and the integrity of the fuel system.
- 1.2 The weight of the canister must be checked.
- 1.3 The canister is connected to a fuel tank, possibly an external one, filled with reference fuel, to 40percent volume of the fuel tank(s).
- 1.4 The fuel temperature in the fuel tank must be between 283 K (10 °C) and 287 K (14 °C).
- 1.5 The (external) fuel tank is heated from 288 K to 318 K (15 °C to 45 °C) (1 °C increase every 9 minutes)
- 1.6 If the canister reaches breakthrough before the temperature reaches 318 K (45 °C), the heat source must be turned off. Then the canister is weighed. If the canister did not reach breakthrough during the heating to 318K (45°C), the procedure from 1.3 of this appendix must be repeated until breakthrough occurs.
- 1.7 Breakthrough may be checked as is described in clause 2.4 and 2.5 of this Appendix or with the use of another sampling and analytical arrangement capable of detecting the emission of hydrocarbons from the canister at breakthrough.
- 1.8 The weight of the canister must be checked.
- 1.9 The canister must be purged with  $25 \pm 5$  liters per minute with the emission laboratory air until 300 bed volume exchanges are reached
- 1.10 The steps of the procedure in clause 1.4 and 1.9 of this Appendix must be repeated nine times. The test may be terminated prior to that, after not less than three ageing cycles, if the weight of the canister after the last cycles has stabilized.
- 1.11 The evaporative emission canister is reconnected and the vehicle restored to its normal operating condition.
- 2.0 One of the methods specified in clause 2.4 and 2 of this Appendix must be used to precondition the evaporative canister. For vehicles with multiple canisters, each canister must be preconditioned separately
- 2.1 Canister emissions are measured to determine breakthrough. Breakthrough is here defined as the point at which the cumulative quantity of hydrocarbons emitted is equal to 2 grams.

- 2.2 Breakthrough may be verified using the evaporative emission enclosure as described in clause 2.4 and 2.5 of this Appendix respectively. Alternatively, breakthrough may be determined using an auxiliary evaporative canister connected downstream of the vehicle's canister. The auxiliary canister must be well purged with dry air prior to loading
- 2.3 The measuring chamber must be purged for several minutes immediately before the test until a stable background is obtained. The chamber air mixing fan(s) must be switched on at this time. The hydrocarbon analyzer must be zeroed and spanned immediately before the test.
- 2.4 **Canister loading with repeated heat builds to breakthrough**
- 2.4.1 The fuel tank(s) of the vehicle(s) is (are) emptied using the fuel tank drain(s). This must be done so as not to abnormally purge or abnormally load the evaporative control devices fitted to the vehicle. Removal of the fuel cap is normally sufficient to achieve this.
- 2.4.2 The fuel tank(s) is (are) refilled with test fuel at a temperature of between 10K to 14K to 40percent  $\pm$  2 percent of the tank's normal volumetric capacity. The fuel cap(s) of the vehicle must be fitted at this point.
- 2.4.3 Within one hour of being refueled the vehicle must be placed, with the engine shut off, in the evaporative emission enclosure. The fuel tank temperature sensor is connected to the temperature recording system. A heat source must be properly positioned with respect to the fuel tank(s) and connected to the temperature controller. The heat source is specified in clause 3.4 of this chapter. In the case of vehicles fitted with more than one fuel tank, all the tanks must be heated in the same way as described below. The temperatures of the tanks must be identical to within  $\pm$  1.5 °K
- 2.4.4 The fuel may be artificially heated to the starting diurnal temperature of 293 K (20°C)  $\pm$  1K.
- 2.4.5 When the fuel temperature reaches at least 292 K (19°C), the following steps must be taken immediately; the purge blower must be turned off; enclosure doors closed and sealed; and measurement initiated of the hydrocarbon level in the enclosure.
- 2.4.6 When the fuel temperature of the fuel tank reaches 293 K (20 °C) a linear heat build of 288 K (15 °C) begins. The fuel must be heated in such a way that the temperature of the fuel during the heating conforms to the function below to within  $\pm$  1.5 K. The elapsed time of the heat build and temperature rise is recorded.

$$T_r = T_0 + 0.2333 \times t$$

Where:

$T_r$  = required temperature (K);

$T_0$  = initial temperature (K);

$t$  = time from start of the tank heat build in minutes.

2.4.7 As soon as breakthrough occurs or when the fuel temperature reaches 308 °K (35 °C), whichever occurs first, the heat source is turned off, the enclosure doors unsealed and opened, the vehicle fuel tank cap(s) removed. If breakthrough has not occurred by the time the fuel temperature reaches 308 °K (35 °C), the heat source is removed from the vehicle, the vehicle removed from the evaporative emission enclosure and the entire procedure outlined in clause 2.4 of this appendix repeated until breakthrough occurs.

**2.5 Butane Loading to Breakthrough**

2.5.1 If the enclosure is used for the determination of the breakthrough (see clause 2.2 of this appendix) the vehicle must be placed, with the engine shut off, in the evaporative emission enclosure.

2.5.2 The evaporative emission canister must be prepared for the canister loading operation. The canister must not be removed from the vehicle, unless access to it in its normal location is so restricted that loading can only reasonably be accomplished by removing the canister from the vehicle. Special care must be taken during this step to avoid damage to the components and the integrity of the fuel system

2.5.3 The canister is loaded with a mixture composed of 50percent butane and 50 percent nitrogen by volume at a rate of 15 grams butane per hour.

2.5.4 As soon as the canister reaches breakthrough, the vapor source must be shut off,

2.5.5 The canister must be purged with 25 ±5 ltr per minute with the emission laboratory air until 300 bed volume exchanges are reached.

2.5.6 The weight of the canister must be checked

2.5.7 The step of the procedure clause 2.5.1 and 2.5.6 must be repeated nine times. The test may be terminated prior to that, after not less than three ageing cycles, if the weight of the canister after the last cycles has stabilized.

2.5.8. The evaporative emission canister must then be reconnected and the vehicle restored to its normal operating condition

**APPENDIX 3 TO CHAPTER 4**  
**CALIBRATION OF EQUIPMENT FOR**  
**EVAPORATIVE EMISSION TESTING**

**1.0 CALIBRATION FREQUENCY AND METHODS**

- 1.1. All equipment shall be calibrated before its initial use and then as often as necessary, and in any case in the month before approval testing. The calibration methods to be used are described in this Appendix.

**2.0 CALIBRATION OF THE ENCLOSURE**

**2.1. Initial determination of enclosure internal volume**

- 2.1.1. Before its initial use, the internal volume of the chamber shall be determined as follows. The internal dimensions of the chamber are carefully measured, allowing for any irregularities such as bracing struts. The internal volume of the chamber is determined from these measurements.

- 2.1.2. The net internal volume is determined by subtracting 0.25 m<sup>3</sup> from the internal volume of the chamber. Alternatively, the actual volume of the test vehicle may be subtracted.

- 2.1.3. The chamber shall be checked as in clause 2.3. of this Appendix. If the propane mass does not tally to within  $\pm 2$  percent with the injected mass, corrective action is required.

**2.2. Determination of chamber background emissions**

This operation determines that the chamber contains no materials that emit significant amounts of hydrocarbons. The check shall be carried out when the enclosure is brought into service, after any operations in it which may affect background emissions and at least once per year.

- 2.2.1. Calibrate the analyzer (if required). The hydrocarbon analyzer shall be set to zero and spanned immediately before the test.

- 2.2.2. Purge the enclosure until a stable hydrocarbon reading is obtained. The mixing fan is turned on, if not already on.

- 2.2.3. Seal the chamber and measure the background hydrocarbon concentration, temperature and barometric pressure. These are the initial readings  $C_{HCi}$ ,  $p_i$  and  $T_i$  used in the enclosure background calculation.

- 2.2.4. The enclosure is allowed to stand undisturbed with the mixing fan on for 4 hours.

- 2.2.5. The hydrocarbon analyzer shall be set to zero and spanned immediately before the end of the test.

- 2.2.6. At the end of this time, use the same analyzer to measure the hydrocarbon concentration in the chamber. The temperature and the barometric pressure are also measured. These are the final readings  $C_{HCF}$ ,  $p_f$  and  $T_f$ .
- 2.2.7. Calculate the change in mass of hydrocarbons in the enclosure over the time of the test in accordance with the equation in clause 2.4. of this Appendix The background emission of the enclosure shall not exceed 400 mg.

### 2.3. Calibration and hydrocarbon retention test of the chamber

The calibration and hydrocarbon retention test in the chamber provides a check on the calculated volume in clause 2.1. of this Appendix and also measures any leak rate.

- 2.3.1. Purge the enclosure until a stable hydrocarbon concentration is reached. Turn on the mixing fan, if it is not already Switched on. The hydrocarbon analyzer shall be calibrated (if necessary) then set to zero and spanned immediately before the test.
- 2.3.2. Seal the enclosure and measure the background concentration, temperature and barometric pressure. These are the initial readings  $C_{HCi}$ ,  $p_i$  and  $T_i$  used in the enclosure calibration.
- 2.3.3. Inject approximately 4 grams of propane into the enclosure. The mass of propane shall be measured to an accuracy of  $\pm 2$  percent of the measured value.
- 2.3.4. Allow the contents of the chamber to mix for five minutes. The hydrocarbon analyzer shall be set to zero and spanned immediately before the following test. Measure the hydrocarbon concentration, temperature and barometric pressure. These are the final readings  $C_{HCF}$ ,  $p_f$  and  $T_f$  for the calibration of the enclosure.
- 2.3.5. Using the readings taken in accordance with clauses 2.3.2 and 2.3.4 of this Appendix and the formula in clause 2.4 of this Appendix calculate the mass of propane in the enclosure. This shall be within  $\pm 2$ percent of the mass of propane measured in accordance with clause 2.3.3 of this Appendix
- 2.3.6. Allow the contents of the chamber to mix for a minimum of 4 hours. Then measure and record the final hydrocarbon concentration, temperature and barometric pressure. The hydrocarbon analyzer shall be set to zero and spanned immediately before the end of the test.
- 2.3.7. Using the formula in clause 2.4 of this Appendix calculate the hydrocarbon mass from the readings taken in clauses 2.3.6 and 2.3.2 of this Appendix The mass may not differ by more than 4percent from the hydrocarbon mass calculated in accordance with clause 2.3.5 of this Appendix

## 2.4. Calculations

The calculation of net hydrocarbon mass change within the enclosure is used to determine the chamber's hydrocarbon background and leak rate. Initial and final readings of hydrocarbon concentration, temperature and barometric pressure are used in the following formula to calculate the mass change:

Equation 1:

$$m_{HC} = k \cdot V \cdot 10^{-4} \cdot \left( \frac{C_{HC_f} \cdot P_f}{T_f} - \frac{C_{HC_i} \cdot P_i}{T_i} \right)$$

where:

$m_{HC}$  = mass of hydrocarbon in grams;

$C_{HC}$  = hydrocarbon concentration in the enclosure (ppm carbon (NB: ppm carbon = ppm propane x 3));

$V$  = enclosure volume in cubic metres as measured in accordance with clause 2.1.1 above;

$T$  = ambient temperature in the enclosure, K;

$p$  = barometric pressure in kPa;

$k = 17.6$ ;

where:

$i$  is the initial reading;  $f$  is the final reading.

## 3.0 CHECKING OF FID HYDROCARBON ANALYZER

### 3.1. Detector response optimization

The FID analyzer shall be adjusted as specified by the instrument manufacturer. Propane in air shall be used to optimize the response on the most common operating range.

### 3.2. Calibration of the HC analyzer

The analyzer shall be calibrated using propane in air and purified synthetic air. A calibration curve shall be established as described in clauses 4.1 to 4.5 of this Appendix below.

### 3.3. Oxygen interference check and recommended limits

The response factor ( $R_f$ ) for a particular hydrocarbon species is the ratio of the FID  $C_1$  reading to the gas cylinder concentration, expressed as ppm  $C_1$ .

The concentration of the test gas shall be such as to give a response of approximately 80 percent of full scale deflection, for the operating range. The concentration shall be known to an accuracy of  $\pm 2$  percent in reference to a gravimetric standard expressed in volume. In addition, the gas cylinder shall be preconditioned for 24 hours at between 293 K (20 °C) and 303 K (30 °C).

Response factors shall be determined when introducing an analyzer into service and thereafter at major service intervals. The reference gas to be used is propane balanced with purified air which shall be taken to give a response factor of 1.00.

The test gas to be used for oxygen interference and the recommended response factor range are given below:

Propane and nitrogen  $0.95 \leq R_f \leq 1.05$ .

#### **4.0 CALIBRATION OF THE HYDROCARBON ANALYZER**

Each of the normally used operating ranges are calibrated by the following procedure:

- 4.1. Establish the calibration curve by at least five calibration points spaced as evenly as possible over the operating range. The nominal concentration of the calibration gas with the highest concentrations shall be at least 80 percent of the full scale.
- 4.2. Calculate the calibration curve by the method of least squares. If the resulting polynomial degree is greater than 3, then the number of calibration points shall be at least the number of the polynomial degree plus 2.
- 4.3. The calibration curve shall not differ by more than 2 percent from the nominal value of each calibration gas.
- 4.4. Using the coefficients of the polynomial derived from clause 4.2 of this Appendix, a table of indicated reading against true concentration shall be drawn up in steps of no greater than 1 percent of full scale. This is to be carried out for each analyser range calibrated. The table shall also contain:
  - a) date of calibration;
  - b) span and zero potentiometer readings (where applicable), nominal scale;
  - c) reference data of each calibration gas used;
  - d) The actual and indicated value of each calibration gas used together with the percentage differences.
  - e) FID fuel and type, FID
  - f) Air Pressure
- 4.5. Alternative technology (e.g. computer, electronically controlled range switch) may be used if it can be shown to the satisfaction of the test agency that it can ensure equivalent accuracy.



## APPENDIX 4 TO CHAPTER 4

CONFORMITY OF PRODUCTION FOR VEHICLES WITH  
EVAPORATIVE EMISSION CONTROL SYSTEM**1.0 CONFORMITY OF PRODUCTION (COP)**

1.1 For routine end of production-line testing, the holder of the approval may demonstrate compliance by sampling vehicles which shall meet the following requirements. Alternatively, the full test procedure described in this Chapter shall be carried out. At the request of the manufacturer, an alternative test procedure may be used, if the procedure has been presented to and has been accepted during the Type approval procedure by the test agency.

**1.2 Test for leakage:**

1.2.1 Vents to the atmosphere from the evaporative emission control system shall be isolated.

1.2.2 A pressure of  $370 \pm 10$  mm of H<sub>2</sub>O shall be applied to the fuel system.

1.2.3 The pressure shall be allowed to stabilize prior to isolating the fuel system from the pressure source.

1.2.4 Following isolation of the fuel system, the pressure shall not drop by more than 50 mm of H<sub>2</sub>O in five minutes.

**1.3 Tests for Venting:**

1.3.1 Vents to the atmosphere from the emission control shall be isolated.

1.3.2 A pressure of  $370 \pm 10$  mm of H<sub>2</sub>O shall be applied to the fuel system.

1.3.3 The pressure shall be allowed to stabilize prior to isolating the fuel system from the present source.

1.3.4 The venting outlets from the emission control systems to the atmosphere shall be reinstated to the production condition.

1.3.5 The pressure of the fuel system shall drop to below 100 mm of H<sub>2</sub>O within two minutes

**1.4 Purge Test:**

1.4.1 Equipment capable of detecting an airflow rate of 0.25 litres in one minutes shall be attached to the purge inlet and a pressure vessel of sufficient size to have negligible effect on the purge system shall be connected via a switching valve to the purge inlet, or alternatively.

1.4.2 The manufacturer may use a flow meter of his own choice, if acceptable to the test agency.

1.4.3 The vehicle shall be operated in such a manner that any design features of the purge system that could restrict purge operation is detected and the circumstances noted.

- 1.4.4 Whilst the engine is operating within the bounds note in 8.4.3 the air flow shall be determined by either.
  - 1.4.4.1 The device being switched in a pressure drop from atmosphere to a level indicating that a volume of 0.25 litres of air has flowed into the evaporative emission control system within one minute; or
  - 1.4.4.2 An alternative flow measuring device with a detectable reading of no less than 0.25 litre per minute.
- 1.5 If the requirements of 1.2, 1.3 and 1.4 of this Appendix are not met or cannot be verified, the SHED test as per Appendix 1 of this Chapter shall be carried out to establish compliance to COP.

In case of COP test failure, manufacturer shall ensure that all necessary steps are taken to re-establish conformity of production as rapidly as possible by conducting a test(s) as per Appendix 1 of this Chapter and inform to test agency.

## **CHAPTER 5**

### **TYPE V TESTS – DURABILITY OF POLLUTION CONTROL DEVICES**

#### **0 INTRODUCTION**

- 0.1 This Chapter describes the procedures for Type V testing to verify the durability of pollution-control devices of L5 category vehicles in accordance with notification.
- 0.2 The Type V test procedure includes mileage accumulation procedures to age the test vehicles in a defined and repeatable way. It also includes the frequency of applied Type I emission verification test procedures conducted before, during and after the mileage accumulation of the test vehicles.

#### **1.0 GENERAL REQUIREMENTS**

- 1.1 The powertrain of test vehicles and pollution-control device type fitted on the test vehicles shall be documented and listed by the manufacturer. The list shall include at a minimum such items as the specifications of the propulsion type and its powertrain, where applicable, the exhaust oxygen sensor(s), catalytic converter(s) type, particulate filter(s) or other pollution-control devices, intake and exhaust systems and any peripheral device(s) that may have an impact on the environmental performance of the approved vehicle. This documentation shall be added to the test report.
- 1.2 After environmental performance Type approval, the manufacturer shall provide evidence of the possible impacts on Type V test results of any modification, to the emission reduction system specification, the pollution-control device type specifications or other peripheral device(s) interacting with the pollution-control devices, in production of the vehicle type. The manufacturer shall provide the test agency with this documentation and evidence upon request in order to prove that the durability performance of the vehicle type with regard to environmental performance will not be negatively affected by any change in vehicle production, retrospective changes in the vehicle specification, changes in the specifications of any pollution-control device type, or changes in peripheral devices fitted on the approved vehicle type.

#### **2.0 SPECIFIC REQUIREMENTS**

##### **2.1 Test vehicle requirements**

- 2.1.1 The test vehicles used for Type V durability testing and in particular the pollution-control and peripheral devices, that are relevant for the emission reduction system, shall be representative of the vehicle type produced in series and placed on the market, with regard to environmental performance.
- 2.1.2 The test vehicles shall be in good mechanical condition at the start of mileage accumulation and it shall not have run more than 100 km after it was first started at the end of the production line. The propulsion and pollution-control devices shall not have been used since its manufacture, with the exception of quality control tests and running of the first 100 km.

- 2.1.3 Regardless of the durability test procedure selected by the manufacturer, all pollution-control devices and systems, both including hardware, powertrain software and powertrain calibration, fitted on the test vehicles shall be installed and operating for the entire mileage accumulation period.
- 2.1.4 The pollution-control devices on the test vehicles shall be permanently marked under surveillance of the test agency before the start of mileage accumulation and be listed together with the vehicle identification number, powertrain software and powertrain calibration sets. The manufacturer shall make that list available at the request of the test agency.
- 2.1.5 Reserved
- 2.1.6 The durability test shall be conducted with commercially available fuel meeting with the requirements for the commercial fuel as specified in notification. If the test vehicles are equipped with a two-stroke engine, lubricating oil shall be used in the proportion and of the grade recommended by the manufacturer in the user manual. The actual quality and quantity used shall be reported.
- 2.1.7 The cooling system of test vehicle shall enable the vehicle to operate at temperatures similar to those obtained during normal road use conditions (oil, coolant, exhaust system, etc.).
- 2.1.8 If the durability test is completed on a test track or road, the reference mass of the test vehicle shall be at least equal to that used for Type I emission tests conducted on a chassis dynamometer.
- 2.1.9 If approved by the test agency and to their satisfaction, the Type V test procedure may be carried out using a test vehicle of which the body style, gear box (automatic or manual) and wheel or tyre size differ from those of the vehicle type for which the environmental performance Type-approval is sought.
- 2.2 In the Type V test procedure, mileage shall be accumulated by driving the test vehicles either on a test track, or on the road or on a chassis dynamometer. The test track or test road shall be selected at the discretion of the manufacturer. The mileage accumulated in the Type I emission verification tests may be added to the total accumulated mileage
  - 2.2.1 **Chassis dynamometer used for mileage accumulation**
    - 2.2.1.1 Chassis dynamometers used to accumulate test Type V durability mileage shall enable the durability mileage accumulation cycle in Appendix 1 of this chapter, as applicable, to be carried out.
    - 2.2.1.2 In particular, the dynamometer shall be equipped with systems simulating the same inertia and resistance to progress as those used in the Type I emission laboratory test in Chapter 2. Emission analysis equipment is not required for mileage accumulation. The same inertia and flywheel settings and calibration procedures shall be used for the chassis dynamometer referred to in Chapter 2 used to accumulate mileage with the test vehicles.

- 2.2.1.3 The test vehicles may be moved to a different bench in order to conduct Type I emission verification tests.
- 2.3 The Type I emission verification tests before, during and after durability mileage accumulation shall be conducted according to the test procedures for emissions after cold start set out in Chapter 2. All Type I emission verification test results shall be listed and made available to the test agency upon request. The results of Type I emission verification tests at the start and the finish of durability mileage accumulation shall be included in the test report. At least the first and last Type I emission verification tests shall be conducted or witnessed by the test agency and reported to them. The test report shall confirm and state whether the test agency conducted or witnessed the Type I emission verification testing.
- 2.4 The difference between the actual mileage accumulation at each emission test interval and the planned mileage accumulation shall not exceed 200 km.
- 2.5 During the emission test (Type-I), if the test is affected by abnormal behavior of the vehicle, test shall be discarded. In any other case, the test result shall be deemed effective.
- The results which are discarded and the reasons thereof shall be recorded in the test report.
- 2.6 If D.F. is less than 1, it shall be deemed as 1.
- If the additive DF is negative, it should be deemed as 0.
- 2.7 D.F. for each applicable pollutant shall be calculated separately.
- 2.8. **Type V test requirements for an L5-category vehicle equipped with a hybrid propulsion**
- 2.8.1. For OVC vehicles:
- The electrical energy device / REESS may be charged twice a day during mileage accumulation.
- For OVC vehicles with an operating mode switch, mileage accumulation shall be driven in the mode which is automatically set after the ignition key is turned (normal mode).
- During the mileage accumulation, a change to another hybrid mode is allowed if necessary in order to continue the mileage accumulation, after agreement and satisfaction of the test agency This hybrid mode change shall be recorded in the test report.
- Pollutant emissions shall be measured under the same conditions as specified by Condition B of the Type I test.
- 2.8.2. For NOVC vehicles:
- For NOVC vehicles with an operating mode switch, mileage accumulation shall be driven in the mode which is automatically set after the ignition key is turned on (normal mode).
- Pollutant emissions shall be measured in the same conditions as in the Type I test.

**3.0 TEST TYPE V, DURABILITY TEST PROCEDURE SPECIFICATIONS**

The durability test may be carried out at the choice of the manufacturer in the following ways prescribed in clause 3.1 and 3.2 of this Chapter

**3.1 Actual durability testing with full mileage accumulation:**

In the durability test procedure with full mileage accumulation to age the test vehicles, the test vehicles shall physically accumulate the full distance set out in the notification and shall be tested in accordance with the defined procedure. The emission test results up to and including the full distance set out in notification shall be lower than the tailpipe emission limits set out in notification. Full mileage accumulation shall mean full completion of the assigned test distance laid down in notification by repeating the driving cycle laid down in Appendix 1 of this chapter.

3.1.1 The emission limits in the applicable Type I emission laboratory test cycle, as set out in notification, of the aged test vehicles shall not exceed when starting mileage accumulation, during the accumulation phase and after full mileage accumulation has been finalized.

3.1.2 Multiple Type I emission tests shall be conducted during the full mileage accumulation phase with a frequency and amount at the choice of the manufacturer as per Type I test procedures and to the satisfaction of the test agency. The Type I emission test results shall provide sufficient statistical relevance to identify the deterioration trend, which shall be representative of the vehicle type with regard to environmental performance as placed on the market (see Figure 1 of this chapter).

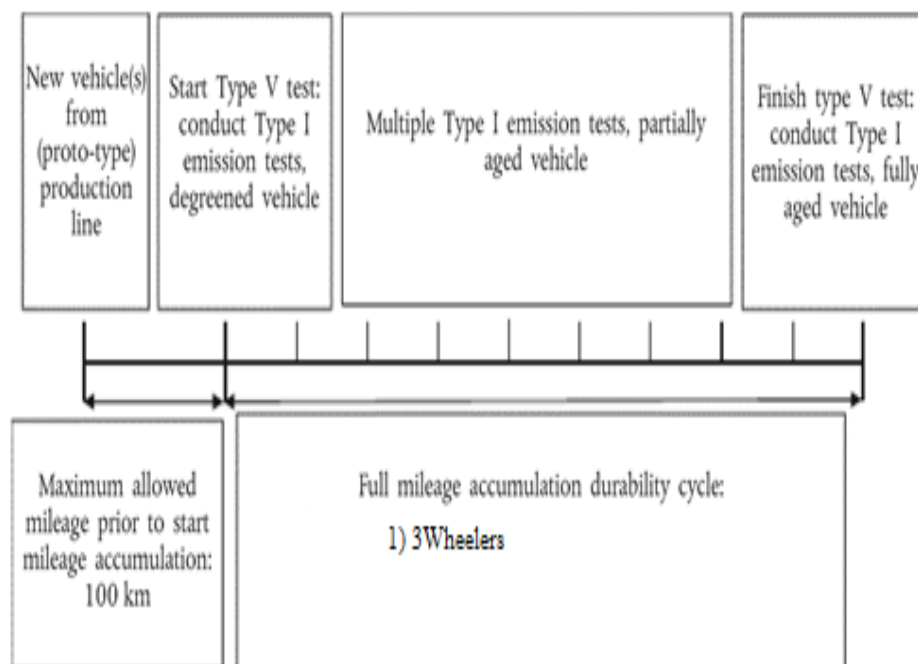

**Figure 1**

**Test Type V – durability test procedure with full mileage accumulation**

3.2 **Actual durability testing with partial mileage accumulation:**

In the durability test procedure with partial mileage accumulation, the test vehicles shall physically accumulate a minimum of 50 percent of the full distance set out in notification and shall be tested in accordance with the defined procedure. The test results shall be extrapolated up to the full distance set out in the notification. Both the test results and the extrapolated results shall be lower than the tailpipe emission limits set out in the notification. Partial mileage accumulation shall involve completion of a minimum of 50 percent of the test distance specified in and compliance with the stop criteria in clause 3.2.3 of this Chapter

3.2.1 The emission limits in the applicable Type I emission laboratory test cycle, as set out in the notification, of the tested aged vehicles are not exceeded at the start of mileage accumulation, during the accumulation phase and after the partial accumulation.

3.2.2 Multiple Type I emission tests shall be conducted during the partial mileage accumulation phase, with the frequency and number chosen by the manufacturer as per Type I test procedures. The Type I emission test results shall provide sufficient statistical relevance to identify the deterioration trend, which shall be representative of the vehicle type with regard to the environmental performance placed on the market (see Figure 2 of this chapter).

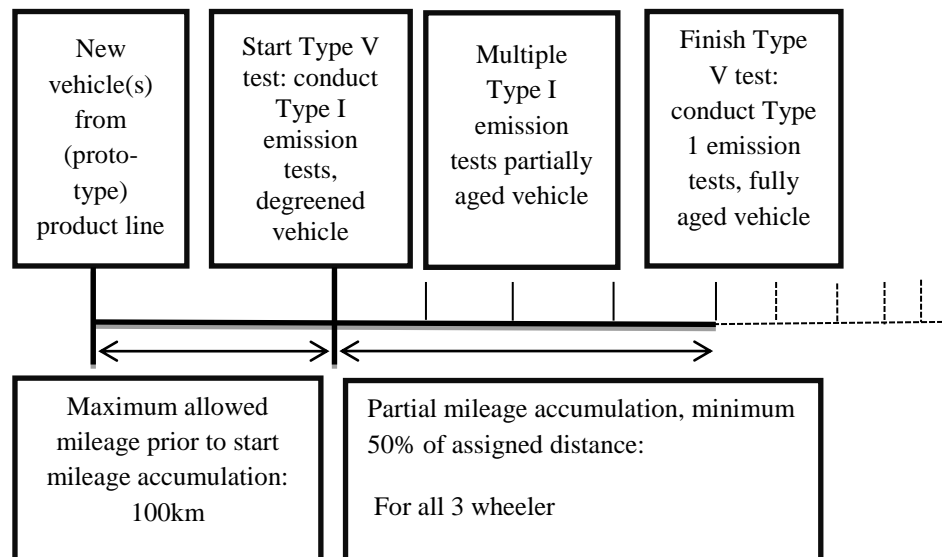

**Figure 2**

**Test Type V: accelerated durability test procedure with partial mileage accumulation**

3.2.3 Stop criteria for the durability test procedure with partial mileage accumulation. Partial mileage accumulation may stop if the following criteria are met:

3.2.3.1 if a minimum of 50 percent of the applicable test distance laid down in Notification has been accumulated; and

- 3.2.3.2 if all the Type I emission verification test results are below the emission limits laid down in notification at all times during the partial mileage accumulation phase; or
- 3.2.3.3 if the manufacturer cannot prove that the stop criteria in clauses 3.2.3.1 and 3.2.3.2 of this Chapter are met, the mileage accumulation shall continue to the point where those criteria are met or to the fully accumulated mileage set out clause 3.1 of this Chapter
- 3.2.4 Data processing and reporting for the durability test procedure with partial mileage accumulation.
- 3.2.4.1 The manufacturer shall use the arithmetic mean of the Type I emission test results at each test interval, with a minimum of two emission tests per test interval. All arithmetic means of Type I emissions test results shall be plotted per CO, HC+NO<sub>x</sub>, NO<sub>x</sub>, and if applicable PM, emission constituent, against accumulation distance rounded to the nearest kilometer.
- 3.2.4.2 The best fit linear line (trend line:  $y = ax + b$ ) shall be fitted and drawn through all these data points based on the method of least squares. This best-fit straight trend line shall be extrapolated over the full durability mileage laid down in notification. At the request of the manufacturer, the trend line may start as of 20 percent of the durability mileage laid down in notification, in order to take into account possible run-in effects of the pollution-control devices.
- 3.2.4.3 A minimum of four calculated arithmetic mean data points shall be used to draw each trend line, with the first at, or before, 20 percent of the durability mileage laid down in the notification and the last one at the end of mileage accumulation; at least two other data points shall be equally spaced between the first and final Type I test measurement distances.
- 3.2.4.3.1 If the planned emission (Type I) test is coinciding with a scheduled maintenance kilometer, the manufacturer shall have following options:
- Option 1: the emission Type I test shall be conducted before or after the maintenance at the choice of manufacturer.
- Option 2: the emission Type I test shall be conducted before and after the maintenance. Arithmetic mean of the results before maintenance and after maintenance shall be calculated separately. These two arithmetic mean values shall be used determining the best fit line.
- 3.2.4.4 The applicable emission limits set out in notification shall be plotted in the graphs per emission constituent laid down in clauses 3.2.4.2 and 3.2.4.3 of this Chapter. The plotted trend line shall not exceed these applicable emission limits at any mileage data point. The graph per HC+NO<sub>x</sub>, CO, NO<sub>x</sub> and if applicable PM, emission constituent plotted against accumulation distance shall be added to the test report. The list with all the Type I emission test results used to establish the best-fit straight trend line shall be made available to the test agency upon request.



Theoretical example of the Type I results of a pollutant is plotted and the best-fit straight trend line is drawn.

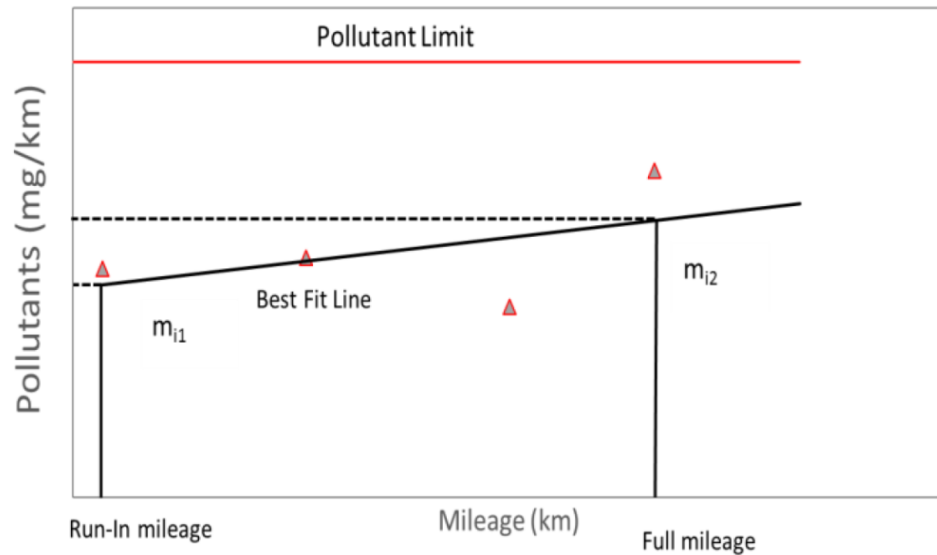

**Figure 3.1**  
**Illustrates full mileage accumulation test**

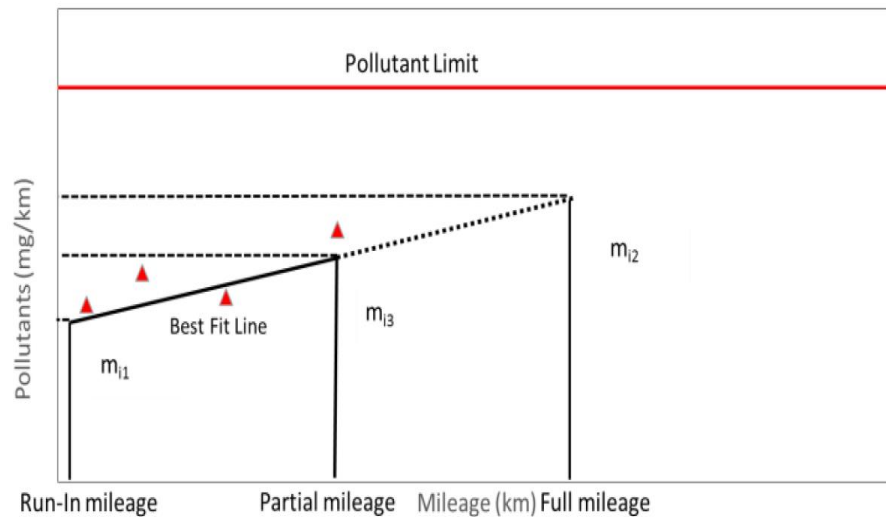

**Figure 3.2**  
**Illustrates partial mileage accumulation test**

3.2.4.5 Trend line parameters  $a$ ,  $x$  and  $b$  of the best-fit straight lines and the calculated pollutant value at the end of mileage according to the vehicle category shall be stated in the test report. The graph for all emission constituents shall be plotted in the test report. In the test report it shall also be stated which measurements were taken or witnessed by the test agency and which by the manufacturer.

#### 3.2.4.6 Calculation of Full D. F :

The D.F for CO, NO<sub>x</sub>+HC, NO<sub>x</sub> and If applicable PM shall be calculated from the best fit line derived from clause 3.2 of this Chapter. D.F is the ratio of mass emission values for each above pollutants calculated from the best fit line at full mileage and that at 1000 km mileage as given in following equation.

$$D.F_{(full)} = \frac{Mi2}{Mi1}$$

At the request of the manufacturer, the additive DF (DF.A.) may be calculated as follows

$$DFA_{(Full)} = Mi2 - Mi1$$

Where

M<sub>i2</sub> = mass emission of the pollutants in g/km at full mileage or after fitment of fully aged golden component.

M<sub>i1</sub> = mass emission of the pollutants in g/km at 1000 km mileage.

#### 3.2.4.7 D.F Extrapolated

In case the test is done for partial mileage accumulation, the M<sub>i2</sub> will be calculated from the extrapolated line at full mileage.

$$D.F_{(extrapolated)} = \frac{Mi2}{Mi1}$$

At the request of the manufacturer, the additive DF (DF.A.) may be calculated as follows:

$$DFA_{(extrapolated)} = Mi2 - Mi1$$

Where

M<sub>i2</sub> = mass emission of the pollutants in g/km at extrapolated full mileage

M<sub>i1</sub> = mass emission of the pollutants in g/km at 1000 km mileage.

#### 3.2.4.8 D.F Extended

Partial accumulation of mileage: D.F(partial) shall be calculated as per following equation:

$$D.F_{(extended)} = \frac{Mi2}{Mi3}$$

Where

M<sub>i2</sub> = mass emission of the pollutants in g/km at full mileage.

M<sub>i3</sub> = mass emission of the pollutants in g/km at partial mileage or after fitment of partially aged golden component.

### 3.4 Durability mileage accumulation cycle

Durability mileage accumulation test cycle specified in Appendix 1 of the chapter shall be conducted to age the test vehicles until the assigned test distance laid down notification is fully completed according to the full mileage accumulation test procedure set out in clause 3.1 of this Chapter or partially completed according to the partial mileage accumulation test procedure in clause 3.2 of this Chapter

- 3.5 Test Type V durability verification testing using ‘golden’ pollution-control devices
- 3.5.1 The pollution-control devices may be removed from the test vehicles after:
- 3.5.1.1 full mileage accumulation according to the test procedure in clause 3.1 of this Chapter is completed, or
- 3.5.1.2 partial mileage accumulation according to the test procedure in clause 3.2 of this Chapter is completed.
- 3.5.2 At the choice of the manufacturer later on in vehicle development, ‘golden’ pollution-control devices may repeatedly be used for durability performance verification and approval demonstration testing on the same vehicle type with regard to the environmental performance by fitting them on a representative parent vehicles representing the propulsion family set out in Chapter 8.
- 3.5.3 Method of marking, storage conditions, storage location and life of “golden” pollution-control device (no. of tests, no. of years, maximum kms etc.) shall be as mutually agreed by the test agency and the manufacturer.
- The ‘golden’ pollution-control devices shall be permanently marked with the consent of the test agency and the marking number, the associated Type I test results and the specifications shall be made available to the test agency upon request.
- 3.5.4 In addition, the manufacturer shall mark and store new, non-aged pollution-control devices with the same specifications as those of the ‘golden’ pollution-control devices and, in the event of a request under clause 3.5.5 of this Chapter, make these available also to the test agency, as a reference base.
- 3.5.5 The test agency shall be given access at any time during or after the environmental performance Type-approval process both to the ‘golden’ pollution-control devices and ‘new, non-aged’ pollution-control devices. The test agency may request and witness a verification test by the manufacturer or may have the ‘new, non-aged’ and ‘golden’ pollution-control devices tested by an independent test laboratory in a non-destructive way.
- 3.6 **Maintenance of vehicle during mileage accumulation:**
- 3.6.1 A scheduled engine tune up shall be conducted in a manner consistent with owner’s manual / service instructions and specifications provided by the manufacturer for use by customer service personnel. Typical servicing items are listed below:
- a. Contact Breaker points & setting
  - b. Ignition timing and setting
  - c. Idle speed and Idle air/fuel mixture setting
  - d. Tappet clearance
  - e. Engine bolt tightening

- f. Spark plugs (Clean, gap setting, replace)
- g. Change of engine and transmission oil, change of elements for oil, air and fuel filters
- h. De-carbonization of engine including silencer in case of two stroke engines.
- i. Adjustment of chains (transmission, valve train)
- j. Adjustment of control cables, clutch etc.
- k. The catalytic converter may be serviced only once during the mileage accumulation, if the failure of the catalytic converter system activates an audible and/ or visual signal which alerts the vehicle operator to the need for catalytic converter system maintenance or if the need for the periodic maintenance of the catalytic converter system is overly signaled to the vehicle operator by appropriate means, e.g., An indicator light or significantly reduced drivability performance.  
The catalytic converter may be serviced as recommended by the vehicle manufacturer.
- l. Fuel injectors (Clean)
- m. O2 sensor
- n. EGR
- o. Catalytic Converter
- p. MIL

**3.6.2 Other maintenance:**

Certain engine components may require maintenance/replacement, which, by its nature cannot be scheduled for periodic interval, but which the manufacturer believes will be necessary, shall be permitted. For example, piston and cylinder replacement caused by piston seizure, excessive wear, which results in the vehicle being inoperative.

- 3.6.2.1 Any unscheduled engine, emission control system, or fuel system adjustment, repair, removal, disassembly, cleaning or replacement on vehicle shall be performed only in case of significantly reduced driving performance, subject to the following:
  - a. part failure or system malfunction or the repairs of such failure or malfunction does not render the vehicle unrepresentative of vehicles in use, and
  - b. does not require direct access to the combustion chamber except for:
    - c. spark plug, fuel injection component, or
    - d. removal or replacement of the removable pre-chamber, or
    - e. decarbonizing
- 3.6.2.2 Equipment, instruments or tools shall not be used to identify the malfunctioning, mal-adjustment or defective engine components unless the same or equivalent equipment, instrument or tools will be available at the dealerships and other service outlets and are used in conjunction with scheduled maintenance on such components.
- 3.6.2.3 Emission measurements shall not be used as a means of determining the need for an unscheduled maintenance.

3.6.2.4 Repairs/replacement to vehicle components of test vehicle, other than engine, emission control system or fuel system, shall be performed only as a result of part failure, vehicle system malfunction

3.6.2.5 In case MIL comes on during the mileage accumulation the fault shall be identified, repaired and reported to the test agency, with relevant documentation data with necessary corrective actions taken.

3.6.3 Records of maintenance activities:

All the maintenance work carried out shall be recorded in the test report. The maintenance work reported in the test report shall reflect in the owner's manual/service manual. The manuals shall be provided to the test agency before the start of production.

During the mileage accumulation, a change to another hybrid mode is allowed if necessary in order to continue the mileage accumulation, after agreement of the test agency—and to the satisfaction of the approval authority. This hybrid mode change shall be recorded in the test report.

Pollutant emissions shall be measured under the same conditions as specified by Condition B of the type I test

2.4.2 For NOVC vehicles:

For NOVC vehicles with an operating mode switch, mileage accumulation shall be driven in the mode which is automatically set after the ignition key is turned on (normal mode).

Pollutant emissions shall be measured in the same conditions as in the type I test.

### **3.0 AGEING BENCH EQUIPMENT AND PROCEDURE.**

3.1. Ageing bench configuration. The ageing bench shall provide the appropriate exhaust flow rate, temperature, air-fuel ratio; exhaust constituents and secondary air injection at the inlet face of the catalyst.

The standard ageing bench consists of an engine, engine controller, and engine dynamometer. Other configurations may be acceptable (e.g. whole vehicle on a dynamometer, or a burner that provides the correct exhaust conditions), as long as the catalyst inlet conditions and control features specified in this Appendix are met.

A single ageing bench may have the exhaust flow split into several streams providing that each exhaust stream meets the requirements of this appendix. If the bench has more than one exhaust stream, multiple catalyst systems may be aged simultaneously.

3.2. Exhaust system installation. The entire catalyst(s)-plus-oxygen sensor(s) system, together with all exhaust piping which connects these components, will be installed on the bench. For engines with multiple exhaust streams, each bank of the exhaust system will be installed separately on the bench in parallel.

For exhaust systems that contain multiple in-line catalysts, the entire catalyst system including all catalysts, all oxygen sensors and the associated exhaust piping will be installed as a unit for ageing. Alternatively, each individual catalyst may be separately aged for the appropriate period of time.

- 3.3. Temperature measurement. Catalyst temperature shall be measured using a thermocouple placed in the catalyst bed at the location where the highest temperature occurs in the hottest catalyst. Alternatively, the feed gas temperature just before the catalyst inlet face may be measured and converted to catalyst bed temperature using a linear transform calculated from correlation data collected on the catalyst design and ageing bench to be used in the ageing process. The catalyst temperature shall be stored digitally at the speed of 1 hertz (one measurement per second)
- 3.4. Air/Fuel measurement. Provisions shall be made for the measurement of the air/fuel (A/F) ratio (such as a wide-range oxygen sensor) as close as possible to the catalyst inlet and outlet flanges. The information from these sensors shall be stored digitally at the speed of 1 hertz (one measurement per second).
- 3.5. Exhaust flow balance. Provisions shall be made to assure that the proper amount of exhaust (measured in grams/second at stoichiometry, with a tolerance of  $\pm 5$  grams/second) flows through each catalyst system that is being aged on the bench.
- The proper flow rate is determined based upon the exhaust flow that would occur in the original vehicle's engine at the steady state engine speed and load selected for the bench ageing in clause 3.6. of this Chapter.
- 3.6. Setup. The engine speed, load, and spark timing are selected to achieve a catalyst bed temperature of  $800\text{ }^{\circ}\text{C}$  ( $\pm 10\text{ }^{\circ}\text{C}$ ) at steady-state stoichiometric operation.
- The air injection system is set to provide the necessary air flow to produce 3.0 % oxygen ( $\pm 0.1\text{ }%$ ) in the steady-state stoichiometric exhaust stream just in front of the first catalyst. A typical reading at the upstream A/F measurement point (required in clause 5 of this Chapter) is lambda 1.16 (which is approximately 3 % oxygen).
- With the air injection on, set the 'Rich' A/F ratio to produce a catalyst bed temperature of  $890\text{ }^{\circ}\text{C}$  ( $\pm 10\text{ }^{\circ}\text{C}$ ). A typical A/F value for this step is lambda 0.94 (approximately 2 % CO).
- 3.7. Ageing cycle. The standard bench ageing procedures use the standard bench cycle (SBC). The SBC is repeated until the amount of ageing calculated from the bench ageing time (BAT) equation is achieved.
- 3.8. Quality assurance. The temperatures and A/F ratio in clauses 3.3 and 3.4 of this Chapter shall be reviewed periodically (at least every 50 hours) during ageing. Necessary adjustments shall be made to assure that the SBC is being appropriately followed throughout the ageing process
- After the ageing has been completed, the catalyst time-at-temperature collected during the ageing process shall be tabulated into a histogram with temperature groups of no larger than  $10^{\circ}\text{C}$ . The BAT equation and the calculated effective reference temperature for the ageing cycle will be used to determine if the appropriate amount of thermal ageing of the catalyst has in fact occurred. Bench ageing will be extended if the thermal effect of the calculated ageing time is not at least 95 % of the target thermal ageing.

3.9 Startup and shutdown. Care should be taken to assure that the maximum catalyst temperature for rapid deterioration (e.g., 1050°C) does not occur during startup or shutdown. Special low temperature startup and shutdown procedures may be used to alleviate this concern.

**4.0 EXPERIMENTALLY DETERMINING THE R-FACTOR FOR BENCH AGEING DURABILITY PROCEDURES**

4.1. The R-factor is the catalyst thermal reactivity coefficient used in the bench ageing time (BAT) equation. Manufacturers may determine the value of R experimentally using the following procedures.

4.2. Using the applicable bench cycle and ageing bench hardware, age several catalysts (minimum of 3 of the same catalyst design) at different control temperatures between the normal operating temperature and the damage limit temperature. Measure emissions (or catalyst inefficiency (1-catalyst efficiency)) for each exhaust constituent. Assure that the final testing yields data between one- and two-times the emission standard

4.3. Estimate the value of R and calculate the effective reference temperature (Tr) for the bench ageing cycle for each control temperature.

4.4. Plot emissions (or catalyst inefficiency) versus ageing time for each catalyst. Calculate the least-squared best-fit line through the data. For the data set to be useful for this purpose the data should have an approximately common intercept [between 0 and 6,400 km. See the following graph for an example.]

4.5. Calculate the slope of the best-fit line for each ageing temperature.

4.6. Plot the natural log (ln) of the slope of each best-fit line (determined in clause 4.5 of this Chapter) along the vertical axis, versus the inverse of ageing temperature (1/(ageing temperature, deg K) along the horizontal axis, Calculate the least squared best-fit lines through the data. The slope of the line is the R-factor. See the following graph for an example

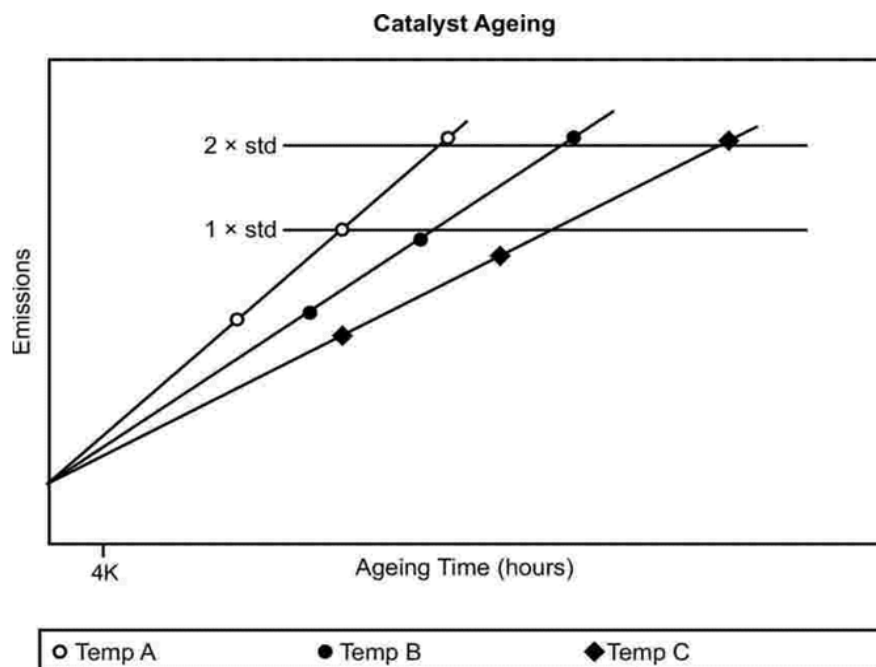

- 4.7. Compare the R-factor to the initial value that was used in accordance with clause 4.3 of this Chapter. If the calculated R-factor differs from the initial value by more than 5 %, choose a new R-factor that is between the initial and calculated values, and then repeat steps of clause 4 of this Chapter, to derive a new R-factor. Repeat this process until the calculated R-factor is within 5 % of the initially assumed R-factor.
- 4.8. Compare the R-factor determined separately for each exhaust constituent. Use the lowest R-factor (worst case) for the BAT equation.

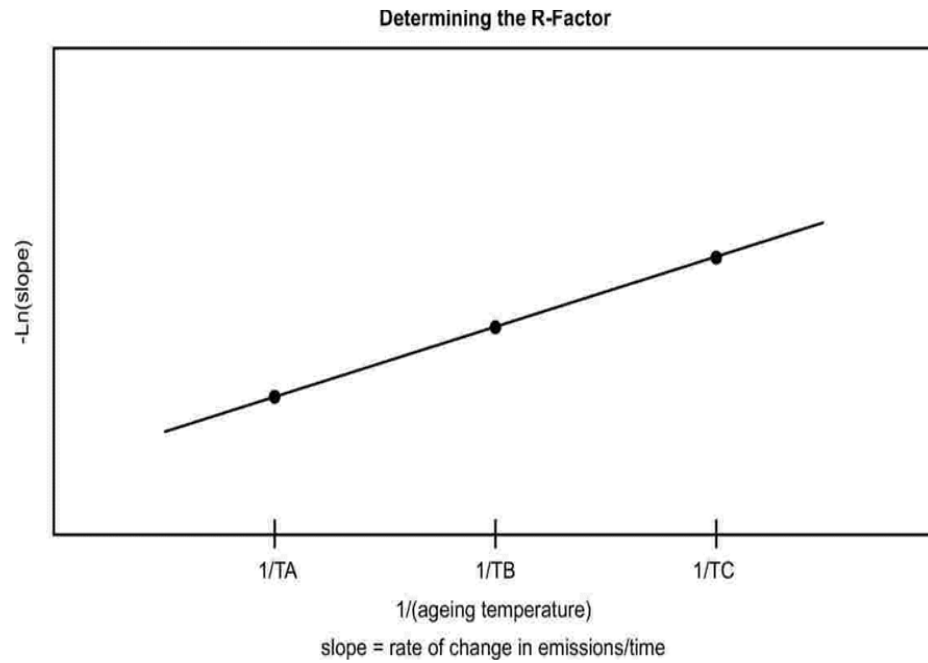



**APPENDIX 1 TO CHAPTER 5  
MILEAGE ACCUMULATION TEST CYCLE**

**1.0 MILEAGE ACCUMULATION:**

- 1.1 Mileage accumulation may be done on road/ test track or on chassis dynamometer, at the option of the vehicle manufacturer
- 1.2 If the mileage accumulation is carried out on roads, the traffic on the selected road shall be such that the lap speeds can be maintained. The details of routes followed and the trends of the traffic pattern shall be recorded
- 1.3 If the mileage accumulation is done on a chassis dynamometer, the chassis dynamometer shall comply with the requirements given in Appendix 3 of Chapter 2. Suitable robotic controls may be used when the mileage accumulation is being carried out on a chassis dynamometer
- 1.4 Mileage accumulation shall be exclusive of the running in period
- 1.5 Speeds for mileage accumulation:
- 1.6 Mileage accumulation shall be done in laps of 6 km. A trip consisting of eleven laps is counted as one test cycle.

The following test cycles shall be followed for three wheelers:

**Table 1**

Test Cycle for all 3W	Lap speed, km/hr										
	1	2	3	4	5	6	7	8	9	10	11
	35	30	35	35	30	30	30	40	30	40	40

- 1.6.1 The breakdown of time vs. speed for each lap is given in Table 1 of this Appendix The time versus speed is pictorially shown in Figures 1, 2 and 3 for laps 1 to 9, 10 and 11 respectively of this Appendix and chapter
- 1.6.2 If the lap speed is not achievable because of the speed capability of the vehicle, the vehicle shall be driven at 90 percent of the actual maximum speed of the vehicle. In such cases, the actual lap speed followed shall be reported.

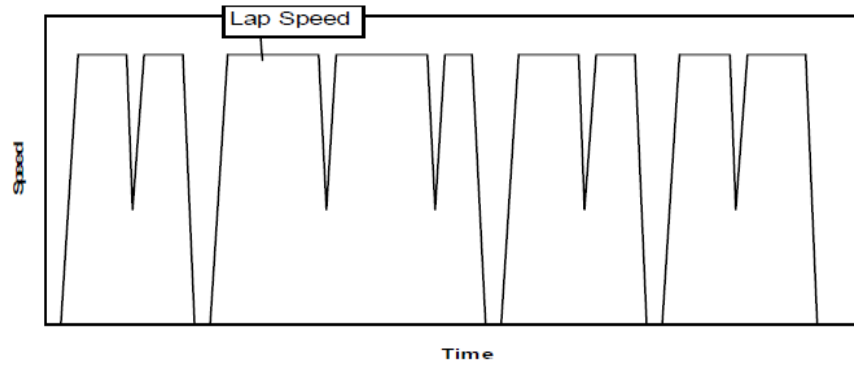

**Figure 1**  
Pictorial representation of Laps 1 to 9

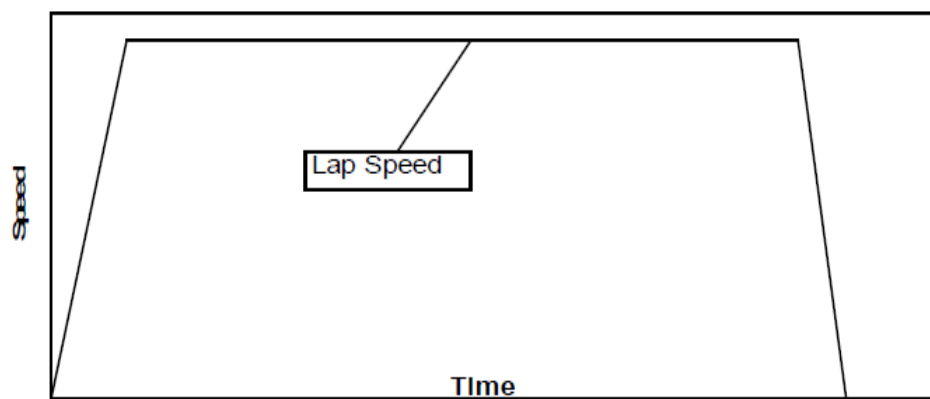

**Figure 2**  
Pictorial representation of Lap 10

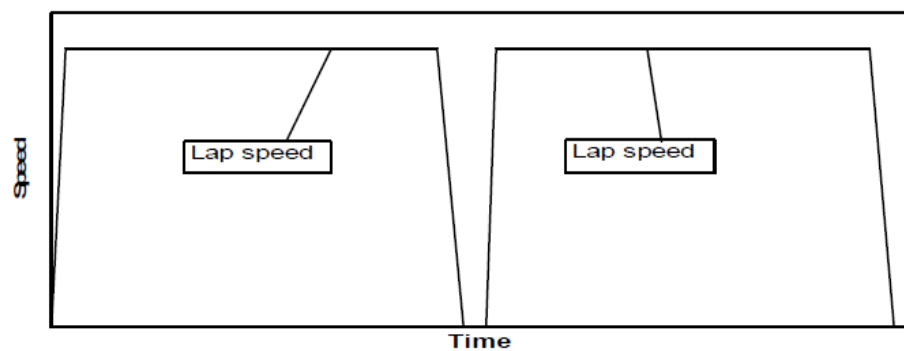

**Figure 3**  
Pictorial representation of Lap 11

## 2.0 GEAR SHIFTING

During lap 1 to 10 gear shifting shall be as recommended by the manufacturer.

In acceleration phase of lap 11, gearshift shall be done at the maximum safe speed of engine recommended by the manufacturer. The gear shifting pattern actually followed shall be reported for a test cycle

**Table 2**

Mode-wise break up for Laps 1 to 9 of Test cycle classification A

Mode	Driving Mode Lap speed-->	Time for each mode (second)		
		30	35	40
1	Acceleration: Idle - Lap speed	13	15	18
2	Steady state cruise	68	68	52
3	Deceleration: Lap speed - 15km/h	10	11	10
4	Acceleration: 15km/h - Lap speed	10	11	10
5	Steady state cruise	45	45	37
6	Deceleration: Lap speed - idle	10	11	10
7	Idle	15	15	15
8	Acceleration: Idle - Lap speed	13	15	18
9	Steady state cruise	100	100	85
10	Deceleration: Lap speed - 15km/h	10	11	10
11	Acceleration: 15km/h - Lap speed	10	11	10
12	Steady state cruise	100	100	85
13	Deceleration: Lap speed - 15km/h	10	11	10
14	Acceleration: 15km/h - Lap speed	10	11	10
15	Steady state cruise	52	33	29
16	Deceleration: Lap speed - idle	10	11	10
17	Idle	15	15	15
18	Acceleration: Idle - Lap speed	13	15	18
19	Steady state cruise	63	63	52
20	Deceleration: Lap speed - 15km/h	10	11	10
21	Acceleration: 15km/h - Lap speed	10	11	10
22	Steady state cruise	52	11	30
23	Deceleration: Lap speed - idle	10	11	10
24	Idle	15	15	15
25	Acceleration: Idle - Lap speed	13	15	18
26	Steady state cruise	52	52	30
27	Deceleration: Lap speed - 15km/h	10	11	10
28	Acceleration: 15km/h - Lap speed	10	11	10
29	Steady state cruise	59	50	44
30	Deceleration: Lap speed - idle	10	11	10

Mode-wise break up for Lap 10 & 11 of Test cycle classification A

Mode	Driving Mode Lap speed-->	Time for each mode (second)	
		For Lap 10	For Lap 11
		40	40
1	Acceleration: Idle - Lap speed	18	10
2	Steady state cruise	515	260
3	Deceleration: Lap speed - idle	18	18
4	Idle	Not applicable	15
5	Acceleration: Idle - Lap speed		10
6	Steady state cruise		260
7	Deceleration: Lap speed - idle		18

## **CHAPTER 6**

### **TEST PROCEDURE FOR ON BOARD DIAGNOSTICS – I (OBD-I)**

#### **1.0 INTRODUCTION**

This chapter applies to the Type Approval procedure for on-board diagnostic I (OBD I) system L5 category.

#### **2.0 DEFINITIONS: REFER OVERALL REQUIREMENTS.**

#### **3.0 APPLICATION FOR TYPE APPROVAL**

3.1 The application for Type approval of a vehicle model with regard to OBD I of the vehicles shall be submitted by the vehicle manufacturer along with duly filled OBD I specification sheet (refer Appendix 1 of this chapter for format) for components monitored by EMS/ECU/Computer & OBD I flow chart application table (refer Appendix 2 of this chapter for format).

3.2 A vehicle representative of the vehicle model to be Type approved shall be submitted to the test agency responsible for conducting tests for compliance to the requirements referred in Clause 5 of this chapter.

#### **4.0 TYPE APPROVAL**

For the purpose of Type approval, manufacturer can choose one of the below mentioned options (4.1 or 4.2 of this Chapter)

4.1 The vehicle submitted for Type approval shall be tested for maximum three discontinuity demonstration tests selected by the test agency out of the OBD I parameters as declared by the vehicle manufacturer, subject to condition mentioned in clause 4.3 of this Chapter.

4.2 Alternatively, the vehicle can be tested for all OBD I parameters for discontinuity demonstration tests, subject to condition mentioned in clause 4.3 of this Chapter.

4.3 If discontinuity demonstration test is conducted on any vehicle model for a particular OBD parameter, demonstration test for such OBD parameter need not be conducted once again in the new vehicle model of same vehicle family submitted for Type approval. In this case the vehicle manufacturer has to fill the vehicle model in which the demonstration test was carried out and date of testing (in DEMO column of Appendix 2 of this chapter)

4.4 If the submitted vehicle meets the requirements of Clause 5 of this Chapter when tested as per the procedure described in Clause 6 of this Chapter for circuit discontinuity of parameters in clause 5.1 of this Chapter, approval of that vehicle model shall be granted.

#### **5.0 REQUIREMENTS**

5.1 Vehicle submitted for Type approval shall contain the OBD monitoring system. Please refer GSR 889(E) dated 16 Sep 2016 for OBD – I monitoring system.

- 5.2 The vehicle manufacturer shall submit a test vehicle along with necessary equipment's, which can simulate the discontinuity of OBD I parameters as declared by the manufacturer for testing.
- 5.3 **Activation of Malfunction Indicator (MI)**
- 5.3.4 Distance traveled since MIL is 'ON' shall be recorded.
- 5.3.5 The OBD system shall incorporate a malfunction indicator readily perceivable to the vehicle operator. The MI must not be used for any other purpose except to indicate emergency start-up or limp-home routines to the driver. The MI shall be visible in all reasonable lighting conditions. When activated, it shall display a symbol in conformity with AIS-071. A vehicle shall not be equipped with more than one general purpose MI for emission-related problems. Separate specific purpose telltales (e.g. brake system, fasten seat belt, oil pressure, etc.) are permitted. The use of red color for an MI is prohibited.
- 5.3.6 The MI shall activate when the vehicle's ignition is in the "key-on" position before engine starting or cranking and de-activate before engine starting after few seconds (or 'on' till engine is started) if no malfunction has previously been detected. For vehicles not equipped with a battery, the MI shall illuminate immediately after engine starting and shall subsequently be deactivated after 5 seconds, if no malfunction has previously been detected.
- 5.3.7 For meeting the requirements of 5.1, the manufacturer shall take appropriate steps to demonstrate that the OBD system will indicate a fault when discontinuity occurs.
- 5.4 The OBD system shall be capable of recording the fault code(s) indicating the status of the emission control system.
- 5.4.1 The distance traveled by the vehicle while the MI is activated must be available at any instant through the serial port on the standard link connector. By means of derogation for vehicles equipped with a mechanically operating odometer that does not allow input to the electronic control unit, 'distance travelled' may be replaced with 'engine operation time' and shall be made available at any moment through the serial port on the standardized diagnostic connector (standardize link connector)

## **6.0 TEST PROCEDURE**

- 6.1 The test Vehicle shall be mounted on the chassis dynamometer along with necessary equipment's of test agency for carrying out test (OBD Scan tool and related accessories need to be provided by manufacturer).
- 6.2 **Initial check**
- 6.2.1 Switch "ON" the ignition and check for MIL "ON". MIL shall be "ON" for few seconds and then may turn "OFF" (in case of vehicle models with such design of MIL operation) or may continue to glow.

- 6.2.2 Start the engine and check for MIL “OFF”.
- 6.2.3 Switch “OFF” the engine and ignition key to “OFF” position.
- 6.3 **Circuit discontinuity check**
- 6.3.1 Vehicle soaking for 6 hours, if necessary for certain OBD parameters as specified by vehicle manufacturer.
- 6.3.2 Open or disconnect the circuit for the OBD parameter to be checked for circuit discontinuity.
- 6.3.3 Switch “ON” the ignition. Check for MIL “ON”.
- 6.3.4 Start the engine and check for MIL “ON”.
- 6.3.4.1 If the OBD I parameter requires engine to be driven for MIL activation, vehicle shall be driven as per driving cycle (Indian Driving Cycle); including key `ON` `OFF` cycles, vehicle can be considered meeting circuit discontinuity when the MIL activates within maximum of 10 (as cold start T=0 sec) driving cycles.
- 6.3.4.2 If the OBD I parameter does not require vehicle to be driven for MIL activation, vehicle can be considered meeting circuit discontinuity for the tested OBD parameter.
- 6.3.4.3 The DTC code shall be retrieved by the OBD Scan tool or any other method as mutually agreed between test agency and vehicle manufacturer.
- 6.3.5 Procedure from 6.3.1 to 6.3.4 of this Chapter shall be repeated for other OBD parameters to be checked for circuit discontinuity.
- 6.4 The requirement of distance traveled or engine operating time since MIL “ON” shall be checked along with one of the circuit discontinuity tests for OBD parameters as specified by vehicle manufacturer by running the vehicle on chassis dynamometer or on road as per driving cycle preferred by the vehicle manufacturer.
- 6.5 The process flow is shown in the figure 1 of this chapter.

## **7.0 MODIFICATIONS OF THE VEHICLE MODEL**

- 7.1 Every modification in the essential characteristics of the vehicle model shall be intimated by the vehicle manufacturer to the test agency which Type approved the vehicle model. The test agency may either,
- 7.2 Consider that the vehicle with the modifications made may still comply with the requirement, or require a further test to ensure further compliance.
- 7.3 In case of 7.2 of this Chapter, the testing agency shall extend the Type approval covering the modified specification or the vehicle model shall be subjected to necessary tests as per the guidelines for extension of approval (clause 8). In case, the vehicle complies with the requirements, the test agency shall extend the Type approval.

**8.0 GUIDELINES FOR EXTENSION OF APPROVAL OF THE VEHICLE FOR OBD I.**

8.1 Approval granted to a vehicle type with respect to the OBD system may be extended to different vehicle types belonging to the same vehicle-OBD family as described in Appendix 3 of this chapter. The engine emission control system must be identical to that of the vehicle already approved and comply with the description of the OBD engine family given in Appendix 3 of this chapter, regardless of the following vehicle characteristics:

- a) engine accessories,
- b) tyres,
- c) equivalent inertia,
- d) cooling system,
- e) overall gear ratio,
- f) transmission type,
- g) type of bodywork.

8.2 In a vehicle model, which is previously approved for OBD parameter, if there is any change in OBD parameter, then the discontinuity testing for the changed OBD parameter only needs to be conducted as mutually agreed between the test agency and vehicle manufacturer if manufacturer can prove that changed OBD parameter don't have any interaction with other OBD parameters.

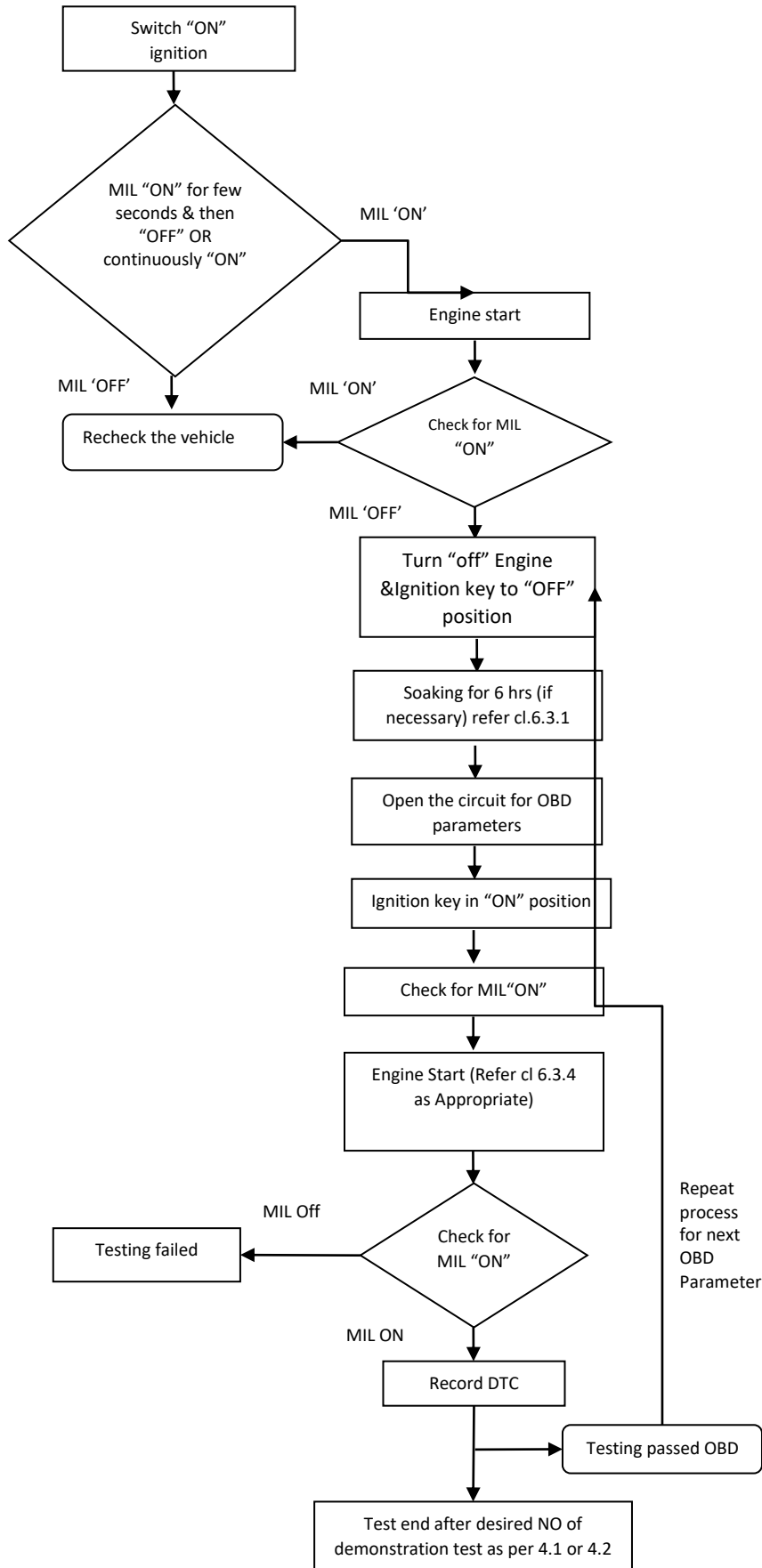

**Figure 1:**  
**OBD-1 TEST PROCEDURE FLOW CHART**







**APPENDIX 3 TO CHAPTER 6**  
**ESSENTIAL CHARACTERISTICS OF THE VEHICLE FAMILY OBD-I**

**1.0 PARAMETERS DEFINING THE OBD FAMILY**

The OBD family may be defined by basic design parameters, which must be common to vehicles within the family. In some cases, there may be interaction of parameters. These effects must also be taken into consideration to ensure that only vehicles with similar exhaust emission characteristics are included within an OBD family.

- 2.0** To this end, those vehicle types whose parameters described below are identical are considered to belong to the same engine-emission control/OBD system combination.

**Engine:**

- a) combustion process (i.e. positive-ignition, compression-ignition, two stroke, four-stroke),
- b) method of engine fuelling (i.e. carburetor or fuel injection).
- c) fuel type (i.e. petrol, diesel, NG, LPG, bi-fuel petrol/NG, bi-fuel petrol/LPG)

**Emission control system:**

- a) type of catalytic converter (i.e. oxidation, three-way, heated catalyst, other),
- b) type of particulate trap,
- c) secondary air injection (i.e. with or without),
- d) exhaust gas recirculation (i.e. with or without)

**OBD parts and functioning:**

- a) the methods of OBD functional monitoring, malfunction detection and malfunction indication to the vehicle driver.

**APPENDIX 4 TO CHAPTER 6**

**MINIMUM MONITORING REQUIREMENTS FOR AN ON-BOARD DIAGNOSTIC (OBD) SYSTEM STAGE I**

**1.0 INTRODUCTION**

The following minimum monitoring requirements shall apply for OBD systems complying with the requirements of OBD stage I regarding electric circuit diagnostics.

**2.0 MONITORING REQUIREMENTS**

2.1. If fitted, the following listed sensors and actuators shall be monitored for electric circuit malfunctions.

<b>Table 1 Scope of OBD stage I</b>	
<b>Items</b>	<b>Scope of OBD I</b>
Table 2 of same Appendix and chapter	yes
Any other sensor or actuator circuit declared by the manufacturer and part of the emission control system	yes
OBD fail thresholds	no

2.2 At a minimum the monitored devices with mandatory circuit diagnostics shall be the following:

<b>Table 2 Overview of devices (if fitted) to be monitored in OBD stage I</b>						
<b>No.</b>	<b>Device circuits</b>		<b>Circuit continuity</b>			<b>Comment No.</b>
		<b>Level, refer to 2.3.</b>	<b>Circuit High</b>	<b>Circuit Low</b>	<b>Open Circuit</b>	
1	Control module (ECU / PCU) internal error	3				( <sup>1</sup> )
<b>Sensor (input to control units)</b>						
1	Accelerator (pedal / handle) position sensor	1 & 3	I	I	I	( <sup>2</sup> )
2	Barometric pressure sensor	1	I	I	I	

3	Camshaft position sensor	3				
4	Crankshaft position sensor	3				
5	Engine coolant temperature sensor	1	I	I	I	
6	Exhaust control valve angle sensor	1	I	I	I	
7	Exhaust gas recirculation sensor	1 & 3	I	I	I	
8	Fuel rail pressure sensor	1	I	I	I	
9	Fuel rail temperature sensor	1	I	I	I	
10	Gear shift position sensor (potentiometer type)	1	I	I	I	
11	Gear shift position sensor (switch type)	3				
12	Intake air temperature sensor	1	I	I	I	
13	Knock sensor (Non- resonance type)	3				
14	Knock sensor (Resonance type)	3				
15	Manifold absolute pressure sensor	1	I	I	I	
16	Mass air flow sensor	1	I	I	I	
17	Engine oil temperature sensor	1	I	I	I	
18	O <sub>2</sub> exhaust sensor (binary / linear) signals	1	I	I	I	
19	Fuel (high) pressure sensor	1	I	I	I	

20	Fuel storage temperature sensor	1	I	I	I	
21	Throttle position sensor	1&3	I	I	I	( <sup>2</sup> )
22	Vehicle speed sensor	3				( <sup>3</sup> )
23	Wheel speed sensor	3				( <sup>3</sup> )
<b>Actuators (output control units)</b>						
1	Evaporative emission system purge control valve	2		I		
2	Exhaust control valve actuator (motor driven)	3				
3	Exhaust gas recirculation control	3				
4	Fuel injector	2		I		( <sup>4</sup> )
5	Idle air control system	1	I	I	I	( <sup>4</sup> )
6	Ignition coil primary control circuits	2		I		( <sup>4</sup> )
7	O <sub>2</sub> exhaust sensor heater	1	I	I	I	( <sup>4</sup> )
8	Secondary air injection system	2		I		( <sup>4</sup> )
9	Throttle by wire actuator	3		I		( <sup>4</sup> )

(<sup>1</sup>) Only in case of an activated limp-home mode or if a throttle by wire system is fitted.

(<sup>2</sup>) If there is only one APS or TPS fitted, APS or TPS circuit rationality monitoring is not mandatory.

(<sup>3</sup>) Only if used as input to ECU / PCU with relevance to environmental performance or when the OBD system fault triggers a limp-home mode.

(<sup>4</sup>) Derogation allowed if manufacturer requests, level 3 instead, actuator signal present only without indication of symptom.

2.2. If there are more of the same device types fitted on the vehicle listed in Table 2 of this Appendix, those devices shall be separately monitored and reported in case of malfunctions. If a malfunction is marked with "I" in Table 2 of this Appendix it shall mean that monitoring is mandatory for OBD stage I.

2.3. Sensors and actuators shall be associated with a specific diagnostic level that defines which type of diagnostic monitoring shall be performed as follows:

2.3.1. Level 1: sensor/actuator of which at least two circuit continuity symptoms can be detected and reported (i.e. short circuit to ground, short circuit to power and open circuit).

2.3.2. Level 2: sensor/actuator of which at least one circuit continuity symptom can be detected and reported (i.e. short circuit to ground, short circuit to power and open circuit).

2.3.3. Level 3: sensor/actuator of which at least one symptom can be detected, but not reported separately.

2.5. **Exemptions regarding detection**

Exemption from detecting certain electric circuit monitoring symptoms may be granted if the manufacturer can demonstrate to the satisfaction of the test agency that the only feasible monitoring strategy would negatively affect vehicle safety or driveability in a significant way.

2.6 Exemption regarding OBD verification tests (test Type VIII)

At the request of the manufacturer and based on a technical justification to the satisfaction of the test agency, certain OBD monitors listed in Table 2 of this Appendix may be exempted from test Type VIII verification tests referred to in Appendix 1.3 of this chapter under the condition that the manufacturer can demonstrate to test agency that:

2.6.1. The malfunction indicator fitted to the vehicle is activated when the malfunction listed in Table 2 of this Appendix occurs:

2.6.1.1. During the same key cycle and;

2.6.1.2. Immediately after expiration of a limited time delay (300 s or less) in that same key cycle; or

2.6.2. Monitoring of some of the items listed in Table 2 of this Appendix is physically not possible and a deficiency has been granted for this incomplete monitor. The comprehensive, technical justification why such an OBD monitor cannot run shall be added to the information folder.

**CHAPTER 7**  
**TEST PROCEDURE FOR ON BOARD DIAGNOSTICS-II (OBD-II)**

**1.0 INTRODUCTION**

This Chapter applies to the functional aspects of on-board diagnostic (OBD - II) System for the emission control of L5.

**2.0 DEFINITIONS: REFER OVERALL REQUIREMENTS.**

**3.0 REQUIREMENTS AND TESTS**

- 3.1 All vehicles shall be equipped with an OBD system so designed, constructed and installed in a vehicle as to enable it to identify types of deterioration or Malfunction over the entire life of the vehicle. In achieving this objective the test agency shall accept that vehicles which have travelled distances in excess of the Type V durability distance, referred to in Clause 3.3.1, may show some deterioration in OBD system performance such that the emission limits given in the applicable Gazette Notification under CMVR may be exceeded before the OBD system signals a failure to the driver of the vehicle.
- 3.1.1 Access to the OBD system required for the inspection, diagnosis, servicing or repair of the vehicle shall be standardised. All emission-related fault codes must be consistent with Clause 6.5.3.4 of Appendix 1 to this Chapter.
- 3.2 The OBD system must be so designed, constructed and installed in a vehicle as to enable it to comply with the requirements of this Chapter during conditions of normal use.
- 3.2.1 **Temporary disablement of the OBD system**
- 3.2.1.1 A manufacturer may disable the OBD system if its ability to monitor is affected by low fuel levels. Disablement shall not occur when the fuel tank level is above 20 percent of the nominal capacity of the fuel tank.
- 3.2.1.2 A manufacturer may disable the OBD system at ambient engine starting temperatures below (-7°C) or at elevations over 2,500 m above sea level provided the manufacturer submits data and/or an engineering evaluation which adequately demonstrate that monitoring would be unreliable when such conditions exist. A manufacturer may also request disablement of the OBD system at other ambient engine starting temperatures if he demonstrates to the test agency with data and/or an engineering evaluation that misdiagnosis would occur under such conditions.
- 3.2.1.3 For vehicles designed to accommodate the installation of power take-off units, disablement of affected monitoring systems is permitted provided disablement occurs only when the power take-off unit is active.
- 3.2.2. Engine misfire - vehicles equipped with positive-ignition engines
- 3.2.2.1 Manufacturers may adopt higher misfire percentage malfunction criteria than those declared to the authority, under specific engine speed and load conditions where it can be demonstrated to the authority that the detection of lower levels of misfire would be unreliable.



3.2.2.2 When a manufacturer can demonstrate to the authority that the detection of higher levels of misfire percentages is still not feasible, or that misfire cannot be distinguished from other effects (e.g. rough roads, transmission shifts, after engine starting; etc.) the misfire monitoring system may be disabled when such conditions exist.

### 3.3. Description of tests

3.3.1 The OBD II tests are carried out on the vehicle used for the Type V durability test, given in Chapter 5, and using the test procedure in Appendix I to this Chapter. OBD II tests are carried out at the conclusion of the Type V durability testing. When no Type V durability testing is carried out, or at the request of the manufacturer, a suitably aged and representative vehicle may be used for these OBD II demonstration tests.

3.3.2 The OBD system must indicate the failure of an emission-related component or system when that failure results in emissions exceeding the threshold limits given in the applicable Gazette Notification under CMVR.

3.3.3 Monitoring requirements for vehicles equipped with positive-ignition engines In satisfying the requirements of Clause 3.3.2 of this Chapter the OBD system must, at a minimum, monitor for

3.3.3.1 Reduction in the efficiency of the catalytic converter with respect to the emissions of HC only. Manufactures may monitor the front catalyst alone or in combination with the next catalyst(s) downstream. Each monitored catalyst or catalyst combination shall be considered malfunctioning when the emissions exceed the threshold given in the applicable Gazette Notification under CMVR.

3.3.3.2 The presence of engine misfire in the engine operating region bounded by the following lines:

(a) a maximum speed of  $4,500 \text{ min}^{-1}$  or  $1,000 \text{ min}^{-1}$  greater than the highest speed occurring during a Type I test cycle, whichever is the lower;

(b) the positive torque line (i.e. engine load with the transmission in neutral);

(c) a line joining the following engine operating points: the positive torque line at  $3,000 \text{ min}^{-1}$  and a point on the maximum speed line defined in (a) above with the engine's manifold vacuum at 13.33 kPa lower than that at the positive torque line.

3.3.3.3 Oxygen sensor deterioration

3.3.3.4 If active on the selected fuel, other emission control system components or systems, or emission-related power train components or systems which are connected to a computer, the failure of which may result in tailpipe emissions exceeding the limits given in the applicable Gazette Notification under CMVR.

- 3.3.3.5 Unless otherwise monitored, any other emission-related power train component connected to a computer, including any relevant sensors to enable monitoring functions to be carried out, must be monitored for circuit continuity.
- 3.3.3.6 the electronic evaporative emission purge control must, at a minimum, be monitored for circuit continuity.
- 3.3.4. Monitoring requirements for vehicles equipped with compression-ignition engines In satisfying the requirements of Clause 3.3.2 of this Chapter the OBD system must monitor:
- 3.3.4.1 Where fitted, reduction in the efficiency of the catalytic converter;
- 3.3.4.2 Where fitted, the functionality and integrity of the particulate trap;
- 3.3.4.3 The fuel-injection system electronic fuel quantity and timing actuator(s) is/are monitored for circuit continuity and total functional failure;
- 3.3.4.4 Other emission control system components or systems, or emission-related power train components or systems, which are connected to a computer, the failure of which may result in tailpipe emissions exceeding the limits given in the applicable Gazette Notification under CMVR. Examples of such systems or components are those for monitoring and control of air mass-flow, air volumetric flow (and temperature), boost pressure and inlet manifold pressure (and relevant sensors to enable these functions to be carried out).
- 3.3.4.5 Unless otherwise monitored, any other emission-related powertrain component connected to a computer must be monitored for circuit continuity.
- 3.3.5 Manufacturers may demonstrate to the Test Agency that certain components or systems need not be monitored if, in the event of their total failure or removal, emissions do not exceed the emission limits given in the official applicable Gazette Notification under CMVR.
- 3.4 A sequence of diagnostic checks for OBD II must be initiated at each engine start and completed at least once provided that the correct test conditions are met. The test conditions must be selected in such a way that they all occur under normal driving as represented by the Type I test.
- 3.5 **Activation of Malfunction Indicator (MI)**
- 3.5.1 The OBD system must incorporate a malfunction indicator readily perceivable to the vehicle operator. The MI must not be used for any other purpose except to indicate emergency start-up or limp home routines to the driver. The MI must be visible in all reasonable lighting conditions. When activated, it must display a symbol in conformity with AIS-071 A vehicle must not be equipped with more than one general purpose MI for emission-related problems. Separate specific purpose tell tales (e.g. brake system, fasten seat belt, oil pressure, etc.) are permitted. The use of red for an MI is prohibited.
- (1) AIS-071 Automotive Vehicles Control Location and Operation Requirements

- 3.5.2. For strategies requiring more than two preconditioning cycles for MI activation, the manufacturer must provide data and/or an engineering evaluation, which adequately demonstrates that the monitoring system is equally effective and timely in detecting component deterioration. Strategies requiring on average more than 10 driving cycles for MI activation are not accepted. The MI must also activate whenever the engine control enters a permanent emission default mode of operation if the emission limits given in the applicable Gazette Notification under CMVR are exceeded or if the OBD system is unable to full fill the basic monitoring requirements specified in Clause 3.3.3 or Clause 3.3.4 of this Chapter. The MI must operate in a distinct warning mode, e.g. a flashing light, under any period during which engine misfire occurs at a level likely to cause catalyst damage, as specified by the manufacturer. The MI shall activate when the vehicle's ignition is in the "key-on" position before engine starting or cranking and de-activate before engine starting after few seconds (or 'on' till engine is started) if no malfunction has previously been detected.
- 3.6. The OBD system must record fault code(s) indicating the status of the emission control system. Separate status codes must be used to identify correctly functioning emission control systems and those emission control systems, which need further vehicle operation to be fully evaluated.
- If the MI is activated due to deterioration or malfunction or permanent emission default modes of operation, a fault code must be stored that identifies the type of malfunction. A fault code must also be stored in the cases referred to in Clause 3.3.3.5 and Clause 3.3.4.5 of this Chapter.
- 3.6.1. The distance travelled by the vehicle while the MI is activated must be available at any instant through the serial port on the standard link connector.
- 3.6.2. In the case of vehicles equipped with positive-ignition engines, misfiring cylinders need not be uniquely identified if a distinct single or multiple cylinder misfire fault code is stored.
- 3.7. **Extinguishing the MI**
- 3.7.1. If misfire at levels likely to cause catalyst damage (as specified by the manufacturer) is not present any more, or if the engine is operated after changes to speed and load conditions where the level of misfire will not cause catalyst damage, the MI may be switched back to the previous state of activation during the first driving cycle on which the misfire level was detected and may be switched to the normal activated mode on subsequent driving cycles. If the MI is switched back to the previous state of activation, the corresponding fault codes and stored freeze-frame conditions may be erased.
- 3.7.2. For all other malfunctions, the MI may be de-activated after three subsequent sequential driving cycles during which the monitoring system responsible for activating the MI ceases to detect the malfunction and if no other malfunction has been identified that would independently activate the MI.

### 3.8. **Erasing a fault code**

- 3.8.1. The OBD system may erase a fault code and the distance travelled and freeze frame information if the same fault is not re-registered in at least 40 engine warm up cycles.

### 3.9. **Bi-fuelled gas vehicles**

In general, for bi-fuelled gas vehicles for each of the fuel types (petrol and NG/LPG) all the OBD requirements as for a mono-fuelled vehicle are applicable. To this end one of the following two options in clauses 3.9.1. or 3.9.2. of this Chapter or any combination thereof shall be used.

#### 3.9.1. **One OBD system for both fuel types.**

- 3.9.1.1. The following procedures shall be executed for each diagnostic in a single OBD system for operation on petrol and on NG/LPG, either independent of the fuel currently in use or fuel type specific:

- (a) activation of malfunction indicator(MI) (see clause 3.5. of this Chapter),
- (b) fault code storage (see clause 3.6. of this Chapter),
- (c) extinguishing the MI (see clause 3.7. of this Chapter),
- (d) erasing a fault code (see clause 3.8. of this Chapter).

For components or systems to be monitored, either separate diagnostics for each fuel type can be used or a common diagnostic.

- 3.9.1.2. The OBD system can reside in either one or more computers. Notwithstanding this requirement, the status code (described in Clause 3.6 of this Chapter) shall indicate fully evaluated control systems for both fuel types (petrol and gas) when the control systems are fully evaluated for one of the fuel types

#### 3.9.2. **Two separate OBD systems, one for each fuel type.**

- 3.9.2.1. The following procedures shall be executed independently of each other when the vehicle is operated on petrol or on NG/LPG:

- (a) activation of malfunction indicator (MI) (see clause 3.5. of this chapter),
- (b) fault code storage (see clause 3.6. of this chapter),
- (c) extinguishing the MI (see clause 3.7. of chapter),
- (d) erasing a fault code (see clause 3.8. of this chapter ).

- 3.9.2.2. The separate OBD systems can reside in either one or more computers.

- 3.9.3. Specific requirements regarding the transmission of diagnostic signals from bio fuelled gas vehicles.

- 3.9.3.1. On a request from a diagnostic scan tool, the diagnostic signals shall be transmitted on one or more source addresses. The use of source addresses

is described in ISO DIS 15031-5 "Road vehicles - communication between vehicles and external test equipment for emissions-related diagnostics - Part 5: Emissions-related diagnostic services", dated 1 November 2001.

- 3.9.3.2. Identification of fuel specific information can be realized:
- (a) by use of source addresses and/or
  - (b) by use of a fuel select switch and/or
  - (c) by use of fuel specific fault codes.
- 3.9.4. Regarding the status code (as described in clause 3.6. of this chapter), one of the following two options has to be used:
- (a) the status code is fuel specific, i.e. use of two status codes, one for each fuel type;
  - (b) the status code shall indicate fully evaluated control systems for both fuel types (petrol and NG/LPG) when the control systems are fully evaluated for one of the fuel types. If none of the diagnostics reporting readiness is fuel type specific, then only one status code has to be supported.

#### **4.0 REQUIREMENTS RELATING TO THE TYPE-APPROVAL OF ON-BOARD DIAGNOSTIC SYSTEMS**

- 4.1. A manufacturer may request to the authority that an OBD system be accepted for Type-approval even though the system contains one or more deficiencies such that the specific requirements of this Chapter are not fully met.
- 4.2. In considering the request, the authority shall determine whether compliance with the requirements of this Chapter is infeasible or unreasonable. The authority shall take into consideration data from the manufacturer that details such factors as, but not limited to, technical feasibility, lead time and production cycles including phase-in or phase-out of engines or vehicle designs and programmed upgrades of computers, the extent to which the resultant OBD system will be effective in complying with the requirements of this chapter and that the manufacturer has demonstrated an acceptable level of effort toward compliance with the requirements of this chapter.
- 4.2.1. The authority will not accept any deficiency request that includes the complete lack of a required diagnostic monitor.
- 4.2.2. The authority will not accept any deficiency request that does not respect the OBD threshold limits in the applicable Gazette Notification under CMVR
- 4.3. In determining the identified order of deficiencies, deficiencies relating to Clause 3.3.3.1, 3.3.3.2 and 3.3.3.3 of this Chapter for positive-ignition engines and Clause 3.3.4.1, 3.3.4.2 and 3.3.4.3 of this Chapter for compression-ignition engines shall be identified first.

4.4. Prior to or at the time of Type-approval, no deficiency shall be granted in respect of the requirements of Clause 6.5, except Clause 6.5.3.4 of Appendix 1 to this Chapter.

4.5. **Deficiency period**

4.5.1. A deficiency may be carried-over for a period of two years after the date of Type approval of the vehicle type unless it can be adequately demonstrated that substantial vehicle hardware modifications and additional lead-time beyond two years would be necessary to correct the deficiency. In such a case, the deficiency may be carried-over for a period not exceeding three years.

4.5.2. A manufacturer may request that the Type-approval grant a deficiency retrospectively when such a deficiency is discovered after the original Type approval. In this case, the deficiency may be carried-over for a period of two years after the date of notification to the Type-approval unless it can be adequately demonstrated that substantial vehicle hardware modifications and additional lead-time beyond two years would be necessary to correct the deficiency. In such a case, the deficiency may be carried-over for a period not exceeding three years.

**5.0 ACCESS TO OBD INFORMATION**

5.1. Upon request, the Type-approval agency shall make Chapter to the Type approval certificate containing the relevant information on the OBD system available to any interested components, diagnostic tools or test equipment manufacturer on a non-discriminatory basis.

5.2. Information can only be requested for replacement or service components that are subject to Type-approval, or for components that form part of a system that is subject to Type approval.

5.3 The request for information must identify the exact specification of the vehicle model for which the information is required. It must confirm that the information is required for the development of replacement or retrofit parts or components or diagnostic tools or test equipment.

**6.0 MODIFICATIONS OF THE VEHICLE MODEL**

6.1 Every modification in the essential characteristics of the vehicle model shall be intimated by the vehicle manufacturer to the test agency which Type approved the vehicle model. The test agency may either,

6.2 Consider that the vehicle with the modifications made may still comply with the requirement, or require a further test to ensure further compliance.

6.3 In case of 6.2 above, the testing agency shall extend the Type approval covering the modified specification or the vehicle model shall be subjected to necessary tests as per the guidelines for extension of approval (clause 7). In case, the vehicle complies with the requirements, the test agency shall extend the Type approval.

**7.0 GUIDELINES FOR EXTENSION OF APPROVAL OF THE VEHICLE FOR OBD.**

7.1 Approval granted to a vehicle type with respect to the OBD system may be extended to different vehicle types belonging to the same vehicle-OBD family as described in Appendix 1 of this chapter. The engine emission control system must be identical to that of the vehicle already approved and comply with the description of the OBD engine family given in Appendix 2 of this chapter, regardless of the following vehicle characteristics:

- a) engine accessories,
- b) tyres,
- c) equivalent inertia,
- d) cooling system,
- e) overall gear ratio,
- f) transmission type,
- g) type of bodywork.

7.2 In a vehicle model, which is previously approved for OBD parameter, if there is any change in OBD parameter, then the testing for the changed OBD parameter only needs to be conducted as mutually agreed between the test agency and vehicle manufacturer if manufacturer can prove that changed OBD parameter don't have any interaction with other OBD parameters.

**APPENDIX 1 TO CHAPTER 7**  
**FUNCTIONAL ASPECTS OF ON BOARD DIAGNOSTIC (OBD) SYSTEM**

**1.0 INTRODUCTION**

This Appendix describes the procedure of the test according to Clause 5 of this Appendix. The procedure describes a method for checking the function of the on board diagnostic (OBD) system installed on the vehicle by failure simulation of relevant systems in the engine management or emission control system. It also sets procedures for determining the durability of OBD systems. The manufacturer must make available the defective components and/or electrical devices which would be used to simulate failures. When measured over the Type I test cycle, such defective components or devices must not cause the vehicle emissions to exceed the OBD threshold limits given in the applicable Gazette Notification under CMVR by more than 20 percent. For electrical failures (short/open circuit), the emissions may exceed the relevant OBD limits by more than 20 percent.

When the vehicle is tested with the defective component or device fitted, the OBD system is approved if the MI is activated. The OBD system is also approved if the MI is activated below the OBD threshold limits given in the applicable Gazette Notification under CMVR.

**2.0 DESCRIPTION OF TEST**

2.1. The testing of OBD – II systems consists of the following phases:

- a) simulation of malfunction of a component of the engine management or emission control system,
- b) preconditioning of the vehicle with a simulated malfunction over preconditioning specified in Clause 6.2.1 or Clause 6.2.2 of this Appendix
- c) driving the vehicle with a simulated malfunction over the Type I test cycle and measuring the emissions of the vehicle,
- d) determining whether the OBD system reacts to the simulated malfunction and indicates malfunction in an appropriate manner to the vehicle driver.

2.2. Alternatively, at the request of the manufacturer, malfunction of one or more components may be electronically simulated according to the requirements of Clause 6 of this Appendix

2.3. Manufacturers may request that monitoring take place outside the Type I test cycle if it can be demonstrated to the authority that monitoring during conditions encountered during the Type I test cycle would impose restrictive monitoring conditions when the vehicle is used in service.

**3.0 TEST VEHICLE AND FUEL**

3.1. Vehicle

The test vehicle shall meet the requirements of 4.2 of Chapter 2.

3.2. Fuel: refer reference Fuel



**4.0 TEST TEMPERATURE AND PRESSURE**

- 4.1. The test temperature and pressure must meet the requirements of the Type I test as described in Chapter 2 of this Part.

**5.0 TEST EQUIPMENT****5.1. Chassis dynamometer**

The chassis dynamometer must meet the requirements of Chapter 2 of this Part.

**6.0 OBD – II TEST PROCEDURE**

- 6.1. The operating cycle on the chassis dynamometer must meet the requirements of Chapter 2 of this Part.

**6.2. Vehicle preconditioning**

- 6.2.1. According to the engine type and after introduction of one of the failure modes given in Clause 6.3 of this Appendix, the vehicle must be preconditioned by driving cycle of Type I tests

- 6.2.2. At the request of the manufacturer, alternative preconditioning methods may be used.

**6.3. Failure modes to be tested****6.3.1. Positive-ignition engine vehicles:**

- 6.3.1.1 Replacement of the catalyst with a deteriorated or defective catalyst or electronic simulation of such a failure.

- 6.3.1.2 Engine misfire conditions according to the conditions for misfire monitoring given in Clause 3.3.3.2 of chapter 7 of this Part.

- 6.3.1.3 Replacement of the oxygen sensor with a deteriorated or defective oxygen sensor or electronic simulation of such a failure.

- 6.3.1.4 Electrical disconnection of any other emission-related component connected to a power-train management computer (if active on the selected fuel type).

- 6.3.1.5 Electrical disconnection of the electronic evaporative purge control device, (if equipped and if active on the selected fuel type) Fuel tank leakage, and fuel system. For this specific failure mode, the Type I test need not be performed.

**6.3.2. Compression-ignition engine vehicles:**

- 6.3.2.1 Where fitted, replacement of the catalyst with a deteriorated or defective catalyst or electronic simulation of such a failure.

- 6.3.2.2 Where fitted, total removal of the particulate trap or, where sensors are an integral part of the trap, a defective trap assembly.

- 6.3.2.3 Electrical disconnection of any fuelling system electronic fuel quantity and timing actuator.

- 6.3.2.4 Electrical disconnection of any other emission-related component connected to a power train management computer.
- 6.3.2.5 In meeting the requirements of clause 6.3.2.3 and 6.3.2.4 of this Appendix and with the agreement between the test agency, the manufacturer must take appropriate steps to demonstrate that the OBD system will indicate a fault when disconnection occurs.
- 6.4. **OBD system test**
  - 6.4.1. **Vehicles fitted with positive-ignition engines:**
    - 6.4.1.1 After vehicle preconditioning according to clause 6.2 of this Appendix, the test vehicle is driven over a Type I test. The MI must activate before the end of this test under any of the conditions given in clause 6.4.1.2 to 6.4.1.5 of this Appendix. The test agency may substitute those conditions by others in accordance with clause 6.4.1.6 of this Appendix. However, the total number of failures simulated must not exceed 4 for the purpose of Type-approval. In the case of testing a bi-fuel gas vehicle, both fuel types shall be used within the maximum of four (4) simulated failures at the discretion of the test agency.
    - 6.4.1.2 Replacement of a catalyst with a deteriorated or defective catalyst or electronic simulation of a deteriorated or defective catalyst that results in emissions exceeding the limit given in the applicable Gazette Notification under CMVR.
    - 6.4.1.3 An induced misfire condition according to the conditions for misfire monitoring given in Clause 3.3.3.2 of Chapter 7 of this Part that results in emissions exceeding any of the limits given in the applicable Gazette Notification under CMVR.
    - 6.4.1.4 Replacement of an oxygen sensor with a deteriorated or defective oxygen sensor or electronic simulation of a deteriorated or defective oxygen sensor that results in emissions exceeding any of the limits given in the applicable Gazette Notification under CMVR.
    - 6.4.1.5 Electrical disconnection of the electronic evaporative purge control device (if equipped and if active on the selected fuel type).
    - 6.4.1.6 Electrical disconnection of any other emission-related power train component connected to a computer that result in emissions exceeding any of the limits given in the applicable Gazette Notification under CMVR (if active on the selected fuel type).
  - 6.4.2 **Vehicles fitted with compression-ignition engines:**
    - 6.4.2.1 After vehicle preconditioning according to clause 6.2 of this Appendix the test vehicle is driven over a Type I test. The MI must activate before the end of this test under any of the conditions given in clause 6.4.2.2 to 6.4.2.5 of this Appendix. The test agency may substitute those conditions by others in accordance with clause 6.4.2.5 of this Appendix. However, the total number of failures simulated must not exceed four for the purposes of Type approval.
    - 6.4.2.2 Where fitted, replacement of a catalyst with a deteriorated or defective catalyst or electronic simulation of a deteriorated or defective catalyst that results in emissions exceeding limits given in the applicable Gazette Notification under CMVR.

- 6.4.2.3 Where fitted, total removal of the particulate trap or replacement of the particulate trap with a defective particulate trap meeting the conditions of clause 6.3.2.2 of this Appendix that results in emissions exceeding the limits given in the applicable Gazette Notification under CMVR.
- 6.4.2.4 With reference to clause 6.3.2.5 of this Appendix disconnection of any fuelling system electronic fuel quantity and timing actuator that results in emissions exceeding any of the limits given in the applicable Gazette Notification under CMVR.
- 6.4.2.5 With reference to clause 6.3.2.5 of this Appendix disconnection of any other emission-related power train component connected to a computer that result in emissions exceeding any of the limits given in the applicable Gazette Notification under CMVR.

## 6.5. Diagnostic signals

- 6.5.1.1 Upon determination of the first malfunction of any component or system, 'freeze-frame' engine conditions present at the time must be stored in computer memory. Should a subsequent fuel system or misfire malfunction occur, any previously stored freeze-frame conditions must be replaced by the fuel system or misfire conditions (whichever occurs first). Stored engine conditions must include, but are not limited to calculated load value, engine speed, fuel trim value(s) (if available), fuel pressure (if available), vehicle speed (if available), coolant, temperature, intake manifold pressure (if available), closed - or open – loop operation (if available) and the fault code which caused the data to be stored. The manufacturer must choose the most appropriate set of conditions facilitating effective repairs for freeze-frame storage.

Only one frame of data is required. Manufacturers may choose to store additional frames provided that at least the required frame can be read by a generic scan tool or a manufacturer recommended diagnostic tester meeting the specifications of clause 6.5.3.2 and 6.5.3.3 of this Appendix. If the fault code causing the conditions to be stored is erased in accordance with Clause 3.7 of this Appendix, the stored engine conditions may also be erased.

- 6.5.1.2 If available, the following signals in addition to the required freeze-frame information must be made available on demand through the serial port on the standardized data link connector, if the information is available to the on-board computer or can be determined using information available to the on-board computer: diagnostic trouble codes, engine coolant temperature, fuel control system status (closed-loop, open-loop, other), fuel trim, ignition timing advance, intake air temperature, manifold air pressure, air flow rate, engine speed, throttle position sensor output value, secondary air status (upstream, downstream or atmosphere), calculated load value, vehicle speed and fuel pressure. The signals must be provided in standard units based on the specifications given in 6.5.3 of this Appendix. Actual signals must be clearly identified separately from default value or limp-home signals.

- 6.5.1.3 For all emission control systems for which specific on-board evaluation tests are conducted (catalyst, oxygen sensor, etc.), except misfire detection, fuel system monitoring and comprehensive component monitoring, the results of the most recent test performed by the vehicle and the limits to which the system is compared must be made available through the serial data port on the standardized data link connector according to the specifications given in 6.5.3 of this Appendix. For the monitored components and systems excepted above, a pass/fail indication for the most recent test results must be available through the data link connector.
- 6.5.1.4 The OBD requirements to which the vehicle is certified (i.e. this Appendix or the alternative requirements specified in clause 2 of Chapter 2) and the major emission control systems monitored by the OBD system consistent with clause 6.5.3.3 of this Appendix must be available through the serial data port on the standardized data link connector according to the specifications given in clause 6.5.3 of this Appendix.
- 6.5.1.5 Vehicles entering into service, the software calibration identification number shall be made available through the serial port on the standardised data link connector. The software calibration identification number shall be provided in a standardised format.
- 6.5.2. The emission control diagnostic system is not required to evaluate components during malfunction if such evaluation would result in a risk to safety or component failure.
- 6.5.3. The emission control diagnostic system must provide for standardised and unrestricted access and conform with the following ISO standards and/or SAE specification.
- 6.5.3.1 One of the following standards with the restrictions as described must be used as the on-board to off-board communications link:
- ISO 9141-2: 1994 (amended 1996) "Road Vehicles -Diagnostic Systems – Part 2: CARB requirements for interchange of digital information";
- SAE J1850: March 1998 "Class B Data Communication Network Interface".
- Emission-related messages must use the cyclic redundancy check and the threebyte header and not use interbyte separation or checksums;
- ISO 14230 - Part 4 "Road Vehicles - Keyword protocol 2000 for diagnostic systems - Part 4: Requirements for emissions-related systems";
- ISO DIS 15765-4 "Road vehicles - Diagnostics on Controller Area Network (CAN) - Part 4: Requirements for emissions-related systems", dated 1 November 2001.
- 6.5.3.2 Test equipment and diagnostic tools needed to communicate with OBD systems must meet or exceed the functional specification given in ISO DIS 15031-4 "Road vehicles Communication between vehicle and external test equipment for emissions-related diagnostics - Part 4: External test equipment", dated 1 November 2001.

- 6.5.3.3 Basic diagnostic data, (as specified in 6.5.1 of this Appendix) and bi-directional control information must be provided using the format and units described in ISO DIS 15031-5 "Road vehicles - Communication between vehicle and external test equipment for emissions-related diagnostics - Part 5: Emissions-related diagnostic services", dated 1 November 2001, and must be available using a diagnostic tool meeting the requirements of ISO DIS 15031-4.

The vehicle manufacturer shall provide to a national standardisation body the details of any emission-related diagnostic data, e.g. PID's, OBD monitor Id's, Test Id's not specified in ISO DIS 15031-5 but related to this standard.

- 6.5.3.4 When a fault is registered, the manufacturer must identify the fault using an appropriate fault code consistent with those given in Section 6.3. of ISO DIS 15031-6 "Road vehicles - Communication between vehicle and external test equipment for emissions-related diagnostics - Part 6: Diagnostic trouble code definitions", relating to "emission related system diagnostic trouble codes". If such identification is not possible, the manufacturer may use diagnostic trouble codes according to Sections 5.3 and 5.6 of ISO DIS 15031-6. The fault codes must be fully accessible by standardised diagnostic equipment complying with the provisions of section 6.5.3.2. The vehicle manufacturer shall provide to a national standardisation body the details of any emission-related diagnostic data, e.g. PID's, OBD monitor Id's, Test Id's not specified in ISO DIS 15031-5 but related to this standard.

- 6.5.3.5 The connection interface between the vehicle and the diagnostic tester must be standardized and must meet all the requirements of ISO 19689 "Motorcycles and Mopeds — Communication between vehicle and external equipment for diagnostics — Diagnostic connector and related electrical circuits, specification and use" or ISO DIS 15031-3 "Road vehicles – Communication between vehicle and external test equipment for emissions-related diagnostics - Part 3: Diagnostic connector and related electrical circuits: specification and use", dated 1 November 2001. The installation position must be subject to agreement of the Test Agency such that it is readily accessible by service personnel but protected from accidental damage during normal conditions of use.

**APPENDIX 2 TO CHAPTER 7**  
**ESSENSIAL CHARACTERISTICS OF THE VEHICLE FAMILY-OBD II**

**1.0           PARAMETERS DEFINING THE OBD FAMILY**

The OBD family may be defined by basic design parameters, which must be common to vehicles within the family. In some cases, there may be interaction of parameters. These effects must also be taken into consideration to ensure that only vehicles with similar exhaust emission characteristics are included within an OBD family.

**2.0**           To this end, those vehicle types whose parameters described below are identical are considered to belong to the same engine-emission control/OBD system combination.

**Engine:**

- a. combustion process (i.e. positive-ignition, compression-ignition, two stroke, four-stroke),
- b. method of engine fuelling (i.e. carburetor or fuel injection).
- c. fuel type (i.e. petrol, diesel, NG, LPG, bi-fuel petrol/NG, bi-fuel petrol/LPG)
- d. Emission control system:
- e. type of catalytic converter (i.e. oxidation, three-way, heated catalyst, other),
- f. type of particulate trap,
- g. secondary air injection (i.e. with or without),
- h. exhaust gas recirculation (i.e. with or without)

**OBD parts and functioning:**

- a. the methods of OBD functional monitoring, malfunction detection and malfunction indication to the vehicle driver

**APPENDIX 3 TO CHAPTER 7**

**MINIMUM MONITORING REQUIREMENTS FOR AN ON BOARD DIAGNOSTIC (OBD) SYSTEM STAGE II**

**1.0 INTRODUCTION**

The following minimum monitoring requirements shall apply for OBD systems complying with the requirements of OBD stage II regarding electric circuit diagnostics.

**2.0 MONITORING REQUIREMENTS**

2.1. If fitted, the following listed sensors and actuators shall be monitored for electric circuit malfunctions.

<b>Table 1 Scope of OBD II</b>	
<b>Items</b>	<b>Scope of OBD II</b>
Table 2 of this Appendix	yes
Any other sensor or actuator circuit declared by the manufacturer	yes
OBD fail thresholds	yes

2.2. At a minimum the monitored devices with mandatory circuit diagnostics shall be the following and may also cause the emissions to exceed the designated OBD II emission thresholds laid down in the notification and/or lead to activation of a default mode that result in a significant reduction of propulsion torque.

<b>Table 2 Overview of devices (if fitted) to be monitored in OBD stage II</b>									
<b>No.</b>	<b>Device circuits</b>		<b>Circuit continuity</b>			<b>Circuit rationality</b>			<b>Comm ent No.</b>
		Level, refer to 2.3.	Circuit High	Circuit Low	Open Circuit	Out of Range	Performance / Plausibility	Signal stuck	Device not operational / Device not present
1	Control module (ECU / PCU) internal error	3							II ( <sup>1</sup> )

Sensor (input to control units)										
1	Accelerator (pedal / handle) position sensor	1 & 3	II	II	II	(II)	(II)	(II)		( <sup>2</sup> )
2	Barometric pressure sensor	1	II	II	II		II			
3	Camshaft position sensor	3	II	II	II				II	( <sup>3</sup> )
4	Crankshaft position sensor	3							II	
5	Engine coolant temperature sensor	1	II	II	II	(II)	(II)	(II)		( <sup>4</sup> )
6	Exhaust control valve angle sensor	1	II	II	II	(II)	(II)	(II)		( <sup>4</sup> )
7	Exhaust gas recirculation sensor	1 & 3	II	II	II	(II)	(II)	(II)		( <sup>4</sup> )
8	Fuel rail pressure sensor	1	II	II	II	(II)	(II)	(II)		( <sup>4</sup> )
9	Fuel rail temperature sensor	1	II	II	II	(II)	(II)	(II)		( <sup>4</sup> )
10	Gear shift position sensor (potentiometer type)	1	II	II	II	(II)	(II)	(II)		( <sup>4</sup> )
11	Gear shift position sensor (switch type)	3					(II)		II	
12	Intake air temperature sensor	1	II	II	II	(II)	(II)	(II)		( <sup>4</sup> )
13	Knock sensor (Non-resonance type)	3					(II)		II	



14	Knock sensor (Resonance type)	3					II			
15	Manifold absolute pressure sensor	1	II	II	II	(II)	(II)	(II)		( <sup>4</sup> )
16	Mass air flow sensor	1	II	II	II	(II)	(II)	(II)		( <sup>4</sup> )
17	Engine oil temperature sensor	1	II	II	II	(II)	(II)	(II)		( <sup>4</sup> )
18	O2 exhaust sensor (binary / linear) signals	1	II	II	II	(II)	(II)	(II)		( <sup>4</sup> )
19	Fuel (high) pressure sensor	1	II	II	II	(II)	(II)	(II)		( <sup>4</sup> )
20	Fuel storage temperature sensor	1	II	II	II	(II)	(II)	(II)		( <sup>4</sup> )
21	Throttle position sensor	1 & 3	II	II	II	(II)	(II)	(II)		( <sup>2</sup> )
22	Vehicle speed sensor	3					(II)		II	( <sup>5</sup> )
23	Wheel speed sensor	3					(II)		II	( <sup>5</sup> )
<b>Actuators (output control units)</b>										
1	Evaporative emission system purge control valve	2	(II)	II	(II)					
2	Exhaust control valve actuator (motor driven)	3					II		II	
3	Exhaust gas recirculation control	3					II			
4	Fuel injector	2		II					(II)	( <sup>6</sup> )
5	Idle air control system	1	II	II	II		II		(II)	( <sup>6</sup> )

6	Ignition coil primary control circuits	2		II					(II)	( <sup>6</sup> )
7	O <sub>2</sub> exhaust sensor heater	1	II	II	II			II	(II)	( <sup>6</sup> )
8	Secondary air injection system	2	(II)	II	(II)				(II)	( <sup>6</sup> )
9	Throttle by wire actuator	3		II					(II)	( <sup>6</sup> )

- (<sup>1</sup>) Only in case of an activated limp-home mode (default mode leading to a significantly reduced propulsion torque) or if a throttle by wire system is fitted.
- (<sup>2</sup>) If there is only one APS or TPS fitted, APS or TPS circuit rationality monitoring is not mandatory.
- (<sup>3</sup>) OBD stage II : level 1 & 3
- (<sup>4</sup>) OBD stage II: two out of three of the circuit rationality malfunctions marked with 'II' shall be monitored in addition to circuit continuity monitoring.
- (<sup>5</sup>) Only if used as input to ECU / PCU with relevance to environmental performance or when the OBD system fault triggers a limp-home mode.
- (<sup>6</sup>) Derogation allowed if manufacturer requests, level 3 instead, actuator signal present only without indication of symptom.

- 2.2. If there are more of the same device types fitted on the vehicle listed in Table 2 of this Appendix, those devices shall be separately monitored and reported in case of malfunctions. If a malfunction is marked with "II" in Table 2 of this appendix it shall mean that monitoring is mandatory for OBD stage II.
- 2.3. Sensors and actuators shall be associated with a specific diagnostic level that defines which type of diagnostic monitoring shall be performed as follows:
  - 2.3.1. Level 1: sensor/actuator of which at least two circuit continuity symptoms can be detected and reported (i.e. short circuit to ground, short circuit to power and open circuit).
  - 2.3.2. Level 2: sensor/actuator of which at least one circuit continuity symptom can be detected and reported (i.e. short circuit to ground, short circuit to power and open circuit).
  - 2.3.3. Level 3: sensor/actuator of which at least one symptom can be detected, but not reported separately.
- 2.4. Two out of three symptoms in circuit continuity as well as in circuit rationality monitoring diagnostic may be combined, e.g. circuit high or open and low circuit / high and low or open circuit / signal out of range or circuit performance and signal stuck.

2.5. Exemptions regarding detection

Exemption from detecting certain electric circuit monitoring symptoms may be granted if the manufacturer can demonstrate to the satisfaction of the test agency

2.5.1 a listed malfunction will not cause emissions to exceed the designated OBD emission threshold set out in the notification; or

2.5.2 a listed malfunction will not cause a significant torque loss; or

2.5.3 the only feasible monitoring strategy would negatively affect vehicle safety or driveability in a significant way.

2.6 Exemption regarding OBD verification tests (test Type VIII)

At the request of the manufacturer and based on a technical justification to the satisfaction of the test agency, certain OBD monitors listed in Table 2 of this Appendix may be exempted from test Type VIII verification tests referred to in Appendix 2.3 of this chapter under the condition that the manufacturer can demonstrate to test agency that:

2.6.1. The malfunction indicator fitted to the vehicle is activated when the malfunction listed in Table 2 of this Appendix occurs:

2.6.1.1. During the same key cycle and;

2.6.1.2. Immediately after expiration of a limited time delay (300 s or less) in that same key cycle; or

2.6.2. Monitoring of some of the items listed in Table 2 of Appendix 2.2 of this Chapter is physically not possible and a deficiency has been granted for this incomplete monitor. The comprehensive, technical justification why such an OBD monitor cannot run shall be added to the information folder.

**CHAPTER 8****VEHICLE PROPULSION FAMILY WITH REGARD TO ENVIRONMENTAL PERFORMANCE DEMONSTRATION TESTS****1.0 INTRODUCTION**

- 1.1 In order to alleviate the test burden on manufacturers when demonstrating the environmental performance of vehicles these may be grouped as a vehicle propulsion family. One or more parent vehicles shall be selected from this group of vehicles by the manufacturer to the satisfaction of the test agency that shall be used to demonstrate environmental performance test Types III – V and VIII.
- 1.2 An L5 category vehicle may continue to be regarded as belonging to the same vehicle propulsion family provided that the vehicle variant, version, propulsion, pollution-control system and OBD parameters listed in Table 1 are identical or remain within the prescribed and declared tolerances.
- 1.3. Vehicle and propulsion family attribution with regard to environmental tests

For the environmental test Types III - V and VIII, a representative parent vehicle shall be selected within the boundaries set by the classification criteria laid down in clause 3 of this Chapter.

**2.0 MODIFICATIONS OF THE VEHICLE MODEL**

- 2.1. Every modification in the essential characteristics, including CVN of the vehicle model shall be intimated by the vehicle manufacturer to the test agency which Type approved the vehicle model. The test agency may either consider that the vehicle with the modifications made may still comply with the requirement, or require a further test to ensure further compliance.
- 2.2. In case of 2.1 above, the testing agency shall extend the Type approval covering the modified specification or the vehicle model shall be subjected to necessary tests. In case, the vehicle complies with the requirements, the test agency shall extend the Type approval.
- 2.3. Any changes to the procedure of PDI and running in concerning emission shall also be intimated to the test agency by the vehicle manufacturer, whenever such changes are carried out.

**3.0 MODEL CHANGES (TYPE I & TYPE II TEST)**

- 3.1. Vehicle models of Different Reference Weights and coast down coefficients: Approval of a vehicle model may under the following conditions be extended to vehicle models which differ from the Type approved only in respect of their reference weight.
  - 3.1.1 Approval may be extended to vehicle model of a reference weight requiring merely the use of the next two higher or any lower equivalent inertia, for 3 wheelers.

- 3.1.2 If the reference weight of the vehicle model for which extension of the Type approval is requested requires the use of a flywheel of equivalent inertia lower than that used for the vehicle model already approved, extension of the Type approval shall be granted if the masses of the pollutants obtained from the vehicle already approved are within the limits prescribed for the vehicle for which extension of the approval is requested.
- 3.1.3 If different body configurations are used with the same power plant and drive line and the change in the load equation due to changes in the coefficient of resistances that is within the limits that would be caused by the change of inertia as permitted by clause 3.1.1 of this Chapter the approval may be extended.
- 3.2 **Vehicle models with different overall gear ratios**
- 3.2.1 Approval granted to a vehicle model may under the following conditions be extended to vehicle models differing from the Type approved only in respect of their overall transmission ratios;
- 3.2.1.1. For each of the transmission ratios used in the Type I Test, it shall be necessary to determine the proportion  $E = (V_2 - V_1)/V_1$ , where  $V_1$  and  $V_2$  are respectively the speed at 1000 rev/min of the engine of the vehicle model Type approved and the speed of the vehicle model for which extension of the approval is requested.
- 3.2.2. If for each gear ratio  $E \leq 8\%$ , the extension shall be granted without repeating the Type I Tests.
- 3.2.3 If for at least one gear ratio,  $E > 8\%$  and if for each gear ratio  $E \leq 13\%$  the Type I test must be repeated, but may be performed in laboratory chosen by the manufacturer subject to the approval of the test agency granting Type approval. The report of the tests shall be submitted to the test agency by the manufacturer.
- 3.3 **Vehicle models of different reference weights, coefficient of coast down and different overall transmission ratios**
- 3.3.1 Approval granted to a vehicle model may be extended to vehicle models differing from the approved type only in respect of their reference weight, coefficient of coast down and their overall transmission ratios, provided that all the conditions prescribed in clause 3.1 and 3.2 of this Chapter are fulfilled.
- Note: When a vehicle type has been approved in accordance with the provisions of Clause 3.1 to 3.3 of this Chapter, such approval may not be extended to other vehicle types.
- 3.4 **Vehicle model with different makes of emission Related components**
- 3.4.1 The names of suppliers of items such as ignition coil, magneto, CB point, air filter, silencer, spark plug, catalytic converter etc. mentioned above, the manufacturers shall inform the test agency that in addition to carried out the Type approval, the names of new alternate suppliers for these items as and when they are being introduced.

3.4.2 At the time of first Type approval or for a subsequent addition of a make for a particular part, work out the combinations of tests in such a way that each make of such parts are tested at least once.

3.5 **Classification criteria**

3.5.1 Legend: -

Wherever “X” is mentioned in the columns for tests, means that the parameter mentioned in classification criteria falls in the same family and hence test is not required for extension of approval or addition of variant/version within the same type.

Wherever “-” is mentioned in the columns for tests, means that the parameter mentioned in classification criteria is not applicable for that test and hence test need not be carried out for extension of approval or addition of variant / version within the same type.

3.5.2 For Test Types III and IV:

1.	Vehicle	
2.	System	
2.1.	propulsion (not) equipped with crankcase ventilation system;	X
2.1.1.	crankcase ventilation system type;	X
2.1.2.	operation principle of crank case ventilation system (breather / vacuum / overpressure);	X

<b>Table 2</b> <b>Classification criteria propulsion family with regard to test Types IV</b>			
No.	Classification criteria description	Test Type IV	
<b>1.0</b>	<b>VEHICLE</b>		
1.1.	Category;	X	
<b>2.0</b>	<b>SYSTEM<sup>1</sup></b>		
2.1.	Propulsion (not) equipped with evaporative emission control system	X	
2.1.1.	Evaporative emission control system type;	X	
2.1.2.	Operation principle of evaporative emission control system (active / passive / mechanically or electronically controlled);	X	
2.1.3.	Identical basic principle of fuel/air metering (e.g. carburetor / single point injection / multi point injection / engine speed density through MAP/ mass airflow);	X	
2.1.4.	Identical material of the fuel tank; <b>Note:</b> material of all metallic fuel tanks are considered to be identical.	X	
2.1.5	Liquid fuel hoses are identical and the surface area is lower;	X	
2.1.6.	The fuel storage capacity declared by the manufacturer is within a range of +10 /- 50 percent of the nominal fuel tank volume	X	
2.1.7.	The fuel storage relief valve pressure setting is identical or higher;	X	
2.1.8.	Identical method of storage of the fuel vapour (i.e. trap form, storage medium, air cleaner (if used for evaporative emission control) etc.);	X	
2.1.9.	Identical or higher volume of the carbon canister the canister or with HC absorbent material or other equivalent	X	
2.1.10.	Identical method of purging of the stored vapour (e.g. air flow, purge volume over the driving cycle);	X	
2.1.11.	Identical method of sealing and venting of the fuel metering system;	X	
<b>Table 3</b> <b>Classification criteria propulsion family with regard to test Types V and VIII</b>			
#	Classification criteria description (Vehicle continues to be regarded as belonging to the same family if the vehicle variant, version, propulsion, pollution-control system and OBD parameters are identical or remain within the prescribed limits.)	Test Type V	Test Type VIII

<b>1.0</b>	<b>VEHICLE</b>		
1.1	Category(L5M / L5N)	X	X
1.2.	the inertia of a vehicle variant(s) or version(s) within two inertia categories above or below the nominal inertia category;	X	X
1.3.	overall gear ratios ( $\pm 8$ percent); (see note below) (See Note #)	X	X
<b>2.0</b>	<b>PROPULSION FAMILY CHARACTERISTICS</b>		
2.1.	Number of engines	X	X
2.2.	Reserved.		
2.3.	number of cylinders of the combustion engine;	X	X
2.4.	engine capacity ( $\pm 2$ percent) of the combustion engine;	X	-
	To include provision for combined weight and coast down coefficient changes from existing TAP		
2.4.1	maximum 30 percent (i.e. the difference in the maximum CC between the lowest value and the highest value does not exceed 30percent of the lowest value)	-	X
2.5.	number and control (variable cam phasing or lift) of combustion engine valves;	X	X
2.6.	Type of fuel ( <b>Note:</b> Example change of petrol/diesel/LPG/CNG and monofuel /bifuel /flex fuel H <sub>2</sub> NG/multifuel calls for retest)	X	X
2.7.	fuel system (Note: Example change of carburettor/scavenging port / port fuel injection /direct fuel injection / common rail / pump-injector / other calls for retest)	X	X
2.8.	fuel storage (Only for vehicles equipped with storage for gaseous fuel)	-	X
2.9.	type of cooling system of combustion engine;	X	X
2.10.	combustion cycle (Note: Example change of PI /CI/two-stroke / four-stroke /other calls for retest);	X	X
2.11.	intake air system (Note: Example change of naturally aspirated /charged (turbocharger / super-charger) / intercooler /boost control) and air induction control (mechanical throttle / electronic throttle control / no throttle calls for retest);	X	X
<b>3.0</b>	<b>POLLUTION CONTROL SYSTEM CHARACTERISTICS</b>		
3.1.	<b>propulsion exhaust (not) equipped with catalytic converter(s);</b>	X	-
3.2	<b>Catalytic converter(s) type;</b>	X	-
3.2.1.	number and elements of catalytic converters;	X	-



3.2.2.	size of catalytic converters (volume of monolith(s) $\pm 15$ percent);	X	-
3.2.3.	operation principle of catalytic activity (oxidising, three-way, heated, SCR, other.);	X	-
3.2.4.	precious metal load (identical or higher);	X	-
3.2.5.	precious metal ratio ( $\pm 15$ percent);	X	-
3.2.6.	substrate (structure and material);	X	-
3.2.7.	cell density;	X	-
3.2.8.	type of casing for the catalytic converter(s);	X	-
3.3	<b>propulsion exhaust (not) equipped with particulate filter (PF);</b>	X	
3.3.1.	PF types;	X	-
3.3.2.	number and elements of PF;	X	-
3.3.3.	size of PF (volume of filter element $\pm 10$ percent);	X	-
3.3.4.	operation principle of PF (partial / wall-flow / other);	X	-
3.3.5.	active surface of PF;	X	-
3.4	<b>Propulsion (not) equipped with periodically regenerating system;</b>	X	
3.4.1.	periodically regenerating system type;	X	-
3.4.2.	operation principle of periodically regenerating system;	X	-
3.5	<b>propulsion (not) equipped with selective catalytic converter reduction (SCR) system;</b>	X	
3.5.1.	SCR system type;	X	-
3.5.2.	operation principle of periodically regenerating system;	X	-
3.6	<b>propulsion (not) equipped with lean NO<sub>x</sub> trap /absorber;</b>	X	
3.6.1.	lean NO <sub>x</sub> trap / absorber type;	X	-
3.6.2.	operation principle of lean NO <sub>x</sub> trap / absorber;	X	-
3.7	<b>Propulsion (not) equipped with a cold-start device or starting aid device(s);</b>	X	X
3.7.1.	cold-start or starting aid device type;	X	-
3.7.2.	operation principle of cold start or starting aid device(s);	X	X
3.7.3.	Activation time of cold-start or starting aid device(s) and /or duty cycle (only limited time activated after cold start / continuous operation);	X	X

3.8	<b>propulsion (not) equipped with O<sub>2</sub> sensor for fuel control;</b>	X	X
3.8.1.	O <sub>2</sub> sensor types;	X	X
3.8.2.	operation principle of O <sub>2</sub> sensor (binary / wide range / other);	X	X
3.8.3.	O <sub>2</sub> sensor interaction with closed-loop fueling system (stoichiometry / lean or rich operation);	X	X
3.9	<b>propulsion (not) equipped with exhaust gas recirculation (EGR) system;</b>	X	
3.9.1.	EGR system types;	X	-
3.9.2.	operation principle of EGR system (internal / external);	X	-
3.9.3.	maximum EGR rate ( $\pm 5$ percent);	X	-
	<p><b>Note:</b> 1. For each of the transmission ratios used in the Type I Test, it shall be necessary to determine the proportion <math>E = (V_2 - V_1)/V_1</math>, where <math>V_1</math> and <math>V_2</math> are respectively the speed at 1000 rev/min of the engine of the vehicle model type approved and the speed of the vehicle model for which extension of the approval is requested. If for each gear ratio <math>E &lt; \pm 8</math>percent, the extension shall be granted without repeating the Type I Tests.</p>		

<b>CHAPTER 9</b>	
<b>TEST TYPE VII REQUIREMENTS: CO<sub>2</sub> EMISSIONS, FUEL CONSUMPTION, ELECTRIC ENERGY CONSUMPTION AND ELECTRIC RANGE</b>	
<b>1.0</b>	<b>INTRODUCTION</b>
1.1.	This Chapter sets out requirements with regard to energy efficiency of L5-category vehicles, in particular with respect to the measurement of CO <sub>2</sub> emissions, fuel or energy consumption as well as the electric range of a vehicle.
1.2.	The requirements laid down in this chapter apply to the following tests of L5-category vehicles equipped with associated power train configurations:  (a) the measurement of the emission of carbon dioxide (CO <sub>2</sub> ) and fuel consumption, the measurement of electric energy consumption and the electric range of L5-category vehicles powered by a hybrid electric powertrain.
<b>2.0</b>	<b>SPECIFICATION AND TESTS</b>
2.1	Description of tests for vehicles powered by a hybrid electric powertrain
2.1.1.	The test agency in charge of the tests shall measure the CO <sub>2</sub> emissions and the electric energy consumption according to the test procedure described in Appendix 3.
2.1.2.	The test results for CO <sub>2</sub> emissions shall be expressed in grams per kilometre (g/km) rounded to the nearest whole number.
2.1.3.	The fuel consumption, expressed in litres per 100 km (in the case of petrol, LPG, ethanol (E85) and diesel) or in kg and m <sup>3</sup> per 100 km (in the case of NG/biomethane, H <sub>2</sub> NG and hydrogen), shall be calculated according to clause 1.4.3 of Chapter 2 by the carbon balance method using the CO <sub>2</sub> emissions measured and the other carbon-related emissions (CO and HC). The results shall be rounded to the first decimal place
2.1.4.	If applicable, electric energy consumption shall be expressed in Watt hours per kilometer (Wh/km), rounded to the nearest whole number.
2.1.5.	The test agency in charge of the tests shall measure the electric range of the vehicle according to the method described in Appendix 1.3. The result shall be expressed in kilometer, rounded to the nearest whole number.
	The electric range measured by this method shall be the only one referred to in promotional material and used for the calculations in Appendix 1.3
2.2	Interpretation of test results

<p>2.2.1.</p>	<p>The CO<sub>2</sub> value or the value of electric energy consumption adopted as the Type-approval value shall be that declared by the manufacturer if this is not exceeded by more than 4 percent by the value measured by the Test Agency. The measured value may be lower without any limitations</p> <p>In the case of vehicles powered by a combustion engine only which are equipped with periodically regenerating systems as defined in clause 3.14.4 of Chapter 1 of this Part the results are multiplied by the factor Ki obtained from Appendix 10 to Chapter 2 before being compared with the declared value.</p>
<p>2.2.2.</p>	<p>If the measured value of CO<sub>2</sub> emissions or electric energy consumption exceeds the manufacturer's declared CO<sub>2</sub> emissions or electric energy consumption value by more than 4 percent, another test shall be run on the same vehicle.</p> <p>Where the average of the two test results does not exceed the manufacturer's declared value by more than 4 percent, the value declared by the manufacturer shall be taken as the Type-approval value.</p>
<p>2.2.3.</p>	<p>If, in the event of another test being run, the average still exceeds the declared value by more than 4 percent, a final test shall be run on the same vehicle. The average of the three test results shall be taken as the Type- approval value.</p>

## APPENDIX 1 TO CHAPTER 9

**METHOD OF MEASURING THE CARBON DIOXIDE EMISSIONS, FUEL CONSUMPTION, ELECTRIC ENERGY CONSUMPTION AND DRIVING RANGE OF VEHICLES POWERED BY A HYBRID ELECTRIC POWERTRAIN**

**1.0 INTRODUCTION**

- 1.1. This Appendix lays down specific provisions on the Type-approval of hybrid electric L5-category vehicles (HEV) as regards measuring carbon dioxide emissions, fuel consumption, electric energy consumption and driving range.
- 1.2. As a general principle for Type VII tests, HEVs shall be tested according to the specified Type I test cycles and requirements and in particular Appendix 6 to Chapter 2, except where modified by this Appendix.
- 1.3. OVC (externally chargeable) HEVs shall be tested under Conditions A and B.  
The test results under Conditions A and B and the weighted average referred to in clause 3 shall be given in the test report.
- 1.4. Driving cycles and gear-shift points
- 1.4.1. The driving cycle in Appendix 6 to Chapter 2 applicable at the time of approval of the vehicle shall be used, including the gear-shifting points in clause 4.4.4.2.3. of Chapter 2.
- 1.4.2. For vehicle conditioning, a combination of the driving cycles in Appendix 6 to Chapter 2 applicable at the time of approval of the vehicle shall be used as laid down in this appendix.

**2.0 CATEGORIES OF HYBRID ELECTRIC VEHICLES (HEV)****Table 1**

Vehicle charging	Off-Vehicle Charging <sup>(1)</sup> (OVC)		Not-off-vehicle Charging <sup>(2)</sup> (NOVC)	
	Without	With	Without	With
Operating mode switch				
<sup>(1)</sup> Also known as 'externally chargeable'.				
<sup>(2)</sup> Also known as 'not externally chargeable'.				

**3.0 OVC (EXTERNALLY CHARGEABLE) HEV WITHOUT AN OPERATING MODE SWITCH**

- 3.1. Two Type I tests shall be performed under the following conditions
- (a) **Condition A:** the test shall be carried out with a fully charged electrical energy device/REESS;
- (b) **Condition B:** the test shall be carried out with an electrical energy device/REESS different stages of the test is set out in Appendix 1.1 of Chapter 9

The profile of the state of charge (SOC) of the electrical energy device/REESS at different stages of the test is set out in Appendix 1.2

### 3.2. Condition A

3.2.1. The procedure shall start with the discharge of the electrical energy device/REESS in accordance with clause 3.2.1.1 of this Appendix.

#### 3.2.1.1. Discharge of the electrical energy device/REESS

The electrical energy device/REESS of the vehicle is discharged while driving (on the test track, on a chassis dynamometer, etc.) in any of the following conditions:

- at a steady speed of 50 km/h until the fuel-consuming engine starts up,
- if a vehicle cannot reach a steady speed of 50 km/h without the fuel-consuming engine starting up, the speed shall be reduced until it can run at a lower steady speed at which the fuel-consuming engine does not start up for a defined time or distance (to be determined by the test agency and the manufacturer to the satisfaction of the test agency),
- in accordance with the manufacturer's recommendation.

The fuel-consuming engine shall be stopped within ten seconds of being automatically started.

#### 3.2.2. Conditioning of the vehicle

3.2.2.1. The test vehicle shall be preconditioned by conducting the applicable Type I test cycle in combination with the applicable gear-shifting in clause 4.4.4.2.3 of Chapter 2.

3.2.2.2. After this preconditioning and before testing, the vehicle shall be kept in a room in which the temperature remains relatively constant between 293.3K and 303.3K (20 °C and 30 °C). This conditioning shall be carried out for at least six hours and continue until the temperatures of the engine oil and coolant, if any, are within  $\pm 2\text{K}$  ( $\pm 2^{\circ}\text{C}$ ) of the temperature of the room, and the electrical energy device/REESS is fully charged as a result of the charging in clause 3.2.2.4 of this Appendix.

3.2.2.3. During soak, the electrical energy device/REESS shall be charged in accordance with the normal overnight charging procedure described in clause 3.2.2.4 of this Appendix.

#### 3.2.2.4. Application of a normal overnight charge

The electrical energy device/REESS shall be charged according to the following process.

##### 3.2.2.4.1. Normal overnight charge procedure

The charging shall be carried out as follows:

- (a) with the on-board charger, if fitted or
- (b) with an external charger recommended by the manufacturer using the charging pattern prescribed for normal charging; and

- (c) in an ambient temperature of between 293 K and 303 K (20 °C and 30 °C). This procedure shall exclude all types of special charge that could be automatically or manually initiated, e.g. equalization or servicing charges. The manufacturer shall declare that no special charge procedure has occurred during the test.

#### 3.2.2.4.2. End-of-charge criteria

The end-of-charge criteria shall correspond to a charging time of twelve hours, except where the standard instrumentation indicates clearly that the electrical energy device/REESS is not yet fully charged, in which case:

Equation 1:

$$\text{the maximum time is} = \frac{\text{3.claimed battery capacity (Wh)}}{\text{Mains power supply (W)}}$$

#### 3.2.3. Test procedure

3.2.3.1 The vehicle shall be started up by the means provided for normal use by the driver. The first cycle starts on the initiation of the vehicle start-up procedure.

3.2.3.2. The test procedures defined in either clause 3.2.3.2.1. or 3.2.3.2.2 of this Appendix may be used.

3.2.3.2.1. Sampling shall begin (BS) before or at the initiation of the vehicle start-up procedure and end on conclusion of the final idling period in the applicable Type I driving cycle (end of sampling (ES)).

3.2.3.2.2. Sampling shall begin (BS) before or at the initiation of the vehicle start-up procedure and continue over a number of repeat test cycles. It shall end on conclusion of the applicable Type I driving cycle during which the battery reached the minimum state of charge in accordance with the following procedure (end of sampling (ES)):

3.2.3.2.2.1. The electricity balance Q (Ah) is measured over each combined cycle, using the procedure in Appendix 1.2 of chapter 9, and used to determine when the battery's minimum state of charge has been reached.

3.2.3.2.2.2. The battery's minimum state of charge is considered to have been reached in combined cycle N if the electricity balance Q measured during combined cycle N + 1 is not more than a 3 percent discharge, expressed as a percentage of the nominal capacity of the battery (in Ah) in its maximum state of charge, as declared by the manufacturer. At the manufacturer's request, additional test cycles may be run and their results included in the calculations in clauses 3.2.3.5. and 3.4 of this Appendix provided that the electricity balance for each additional test cycle shows less discharge of the battery than over the previous cycle.

3.2.3.2.2.3. Between each pair of cycles, a hot soak period of up to ten minutes is allowed. The powertrain shall be switched off during this period.

- 3.2.3.3. The vehicle shall be driven according to the applicable Type I driving cycle and gear-shifting prescriptions in Chapter 2.
- 3.2.3.4. The tailpipe emissions of the vehicle shall be analyzed according to the provisions of Chapter 2 in force at the time of approval of the vehicle.
- 3.2.3.5. The CO<sub>2</sub> emission and fuel consumption results from the test cycle(s) for Condition A shall be recorded (respectively  $m_1$  (g) and  $c_1$  (l)). Parameters  $m_1$  and  $c_1$  shall be the sums of the results of the N combined cycles run.

Equation 2:

$$m_1 = \sum_1^N m_i$$

Equation 3:

$$c_1 = \sum_1^n c_i$$

- 3.2.4. Within the 30 minutes after the conclusion of the cycle, the electrical energy device/REESS shall be charged according to clause 3.2.2.4 of this Appendix. The energy measurement equipment, placed between the mains socket and the vehicle charger, measures the charge energy  $e_1$  (Wh) delivered from the mains.
- 3.2.5. The electric energy consumption for Condition A shall be  $e_1$  (Wh).

### 3.3. **Condition B**

- 3.3.1. Conditioning of the vehicle
  - 3.3.1.1. The electrical energy device/REESS of the vehicle shall be discharged in accordance with clause 3.2.1.1 of this Appendix. At the manufacturer's request, a conditioning in accordance with clause 3.2.2.1 of this Appendix may be carried out before electrical energy/power storage discharge.
  - 3.3.1.2. Before testing, the vehicle shall be kept in a room in which the temperature remains relatively constant between 293.3K and 303.3K (20 °C and 30 °C). This conditioning shall be carried out for at least six hours and continue until the temperatures of the engine oil and coolant, if any, are within  $\pm 2$  K of the temperature of the room.
- 3.3.2. Test procedure
  - 3.3.2.1. The vehicle shall be started up by the means provided for normal use by the driver. The first cycle starts on the initiation of the vehicle start-up procedure.
  - 3.3.2.2. Sampling shall begin (BS) before or at the initiation of the vehicle start-up procedure and end on conclusion of the final idling period in the applicable Type I driving cycle (end of sampling (ES)) of Appendix 6 of Chapter 2.
  - 3.3.2.3. The vehicle shall be driven using the applicable Type I driving cycle and gear-shifting prescriptions set out in Appendix 6 to Chapter 2.



3.3.2.4. The tailpipe emissions of the vehicle shall be analyzed according to the provisions of Chapter 2.

3.3.2.5. The test results for Condition B shall be recorded ( $m_2$  (g) and  $c_2$  (l) respectively

3.3.3. Within 30 minutes of the end of the cycle, the electrical energy device/REESS shall be charged in accordance with clause 3.2.2.4 of this Appendix

The energy measurement equipment, placed between the mains socket and the vehicle charger, measures the energy charge  $e_2$  (Wh) delivered from the mains.

3.3.4. The electrical energy device/REESS of the vehicle shall be discharged in accordance with clause 3.2.1.1 of this Appendix.

3.3.5. Within 30 minutes of the discharge, the electrical energy device/REESS shall be charged in accordance with clause 3.2.2.4 of this Appendix.

The energy measurement equipment, placed between the mains socket and the vehicle charger, measures the energy charge  $e_3$  (Wh) delivered from the mains.

3.3.6. The electric energy consumption  $e_4$  (Wh) for Condition B is:

Equation 4:  $e_4 = e_2 - e_3$

3.4. Test results

3.4.1. The CO<sub>2</sub> values shall be:

Equation 5:  $M_1 = m_1 / D_{\text{test1}}$  (g/km) and

Equation 6:  $M_2 = m_2 / D_{\text{test2}}$  (g/km)

where:

$D_{\text{test1}}$  and  $D_{\text{test2}}$  = the actual distances driven in the tests performed under Conditions A (clause 3.2.) and B (clause 3.3.) respectively, and

$m_1$  and  $m_2$  = test results determined in clauses 3.2.3.5. and 3.3.2.5 of this Appendix respectively.

3.4.2.1. For testing in accordance with clause 3.2.3.2.1 of this Appendix

The weighted CO<sub>2</sub> values shall be calculated as follows:

Equation 7:

$$M = (D_e \cdot M_1 + D_{av} \cdot M_2) / (D_e + D_{av})$$

where:

$M$  = mass emission of CO<sub>2</sub> in grams per kilometer,

$M_1$  = mass emission of CO<sub>2</sub> in grams per kilometer with a fully charged electrical energy device/REESS,

- $M_2$  = mass emission of CO<sub>2</sub> in grams per kilometer with an electrical energy device/REESS in minimum state of charge (maximum discharge of capacity),
- $D_e$  = electric range of the vehicle determined according to the procedure described in Appendix 1.3., where the manufacturer shall provide the means for performing the measurement with the vehicle running in pure electric operating state,
- $D_{av}$  = average distance between two battery recharges,
- $D_{av}$  = :
- 25 km for an L5-category vehicle with an engine capacity of < 150 cm<sup>3</sup>;
- 25 km for an L5-category vehicle with an engine capacity of ≥ 150 cm<sup>3</sup> and v max < 130 km/h;
- 25 km for an L5-category vehicle with an engine capacity of ≥ 150 cm<sup>3</sup> and v max ≥ 130 km/h.

3.4.2.2. For testing in accordance with clause 3.2.3.2.2 of this Appendix

Equation 8:

$$M = (D_{ovc} \cdot M_1 + D_{av} \cdot M_2) / (D_{ovc} + D_{av})$$

where:

- $M$  = mass emission of CO<sub>2</sub> in grams per kilometer,
- $M_1$  = mass emission of CO<sub>2</sub> in grams per kilometer with a fully charged electrical energy device/REESS,
- $M_2$  = mass emission of CO<sub>2</sub> in grams per kilometer with an electrical energy device/REESS in minimum state of charge (maximum discharge of capacity),
- $D_{ovc}$  = OVC range according to the procedure described in Appendix 1.3,
- $D_{av}$  = average distance between two battery recharges,
- $D_{av}$  = :
- 25 km for an L5-category vehicle with an engine capacity of < 150 cm<sup>3</sup>;
- 25 km for an L5-category vehicle with an engine capacity of ≥ 150 cm<sup>3</sup> and v max < 130 km/h;
- 25 km for an L5-category vehicle with an engine capacity of ≥ 150 cm<sup>3</sup> and v max ≥ 130 km/h

[**Note:**  $D_{av}$  is changed to align with AIS-102 and FAME incentive notification S.O.830(E)]

3.4.3. The fuel consumption values shall be:

Equation 9:

$$C_1 = \frac{100 * c_1}{D_{test1}}$$

Equation 10:

$$C_2 = \frac{100 * c_2}{D_{test2}}$$

(l/100 km) for liquid fuels and (kg/100) km for gaseous fuel

where:

$D_{test1}$  and  $D_{test2}$  = the actual distances driven in the tests performed under Conditions A (clause 3.2.) and B (clause 3.3.) respectively, and  $C_1$  and  $C_2$  = test results determined in clauses 3.2.3.8. and 3.3.2.5 of this Appendix respectively.

3.4.4. The weighted fuel consumption values shall be calculated as follows:

3.4.4.1. For testing in accordance with clause 3.2.3.2.1 of this Appendix

Equation 11:

$$C = \frac{D_e \cdot C_1 + D_{av} \cdot C_2}{D_e + D_{av}}$$

where:

$C$  = fuel consumption in l/100 km,

$C_1$  = fuel consumption in l/100 km with a fully charged electrical energy device/REESS,

$C_2$  = fuel consumption in l/100 km with an electrical energy device/REESS in minimum state of charge (maximum discharge of capacity),

$D_e$  = electric range of the vehicle determined according to the procedure described in Appendix 1.3., where the manufacturer shall provide the means for performing the measurement with the vehicle running in pure electric operating state,

$D_{av}$  = average distance between two battery recharges,

$D_{av}$  = :

25 km for an L5-category vehicle with an engine capacity of < 150 cm<sup>3</sup>;

25 km for an L5-category vehicle with an engine capacity of ≥ 150 cm<sup>3</sup> and  $v_{max} < 130$  km/h;

25 km for an L5-category vehicle with an engine capacity of ≥ 150 cm<sup>3</sup> and  $v_{max} \geq 130$  km/h.

[**Note:**  $D_{av}$  is changed to align with AIS-102 and FAME incentive notification S.O.830(E)]

3.4.4.2. For testing in accordance with clause 3.2.3.2.2 of this Appendix

Equation 12:

$$C = (D_{ovc} \cdot C_1 + D_{av} \cdot C_2) / (D_{ovc} + D_{av})$$

where:

C = fuel consumption in l/100 km,

C<sub>1</sub> = fuel consumption in l/100 km with a fully charged electrical energy device/REESS,

C<sub>2</sub> = fuel consumption in l/100 km with an electrical energy device/REESS in minimum state of charge (maximum discharge of capacity),

D<sub>ovc</sub> = OVC range according to the procedure described in Appendix 1.3 of chapter 9.

D<sub>av</sub> = average distance between two battery recharges,

D<sub>av</sub> = :

25 km for an L5-category vehicle with an engine capacity of < 150 cm<sup>3</sup>;

25 km for an L5-category vehicle with an engine capacity of ≥ 150 cm<sup>3</sup> and v max < 130 km/h;

25 km for an L5-category vehicle with an engine capacity of ≥ 150 cm<sup>3</sup> and v max ≥ 130 km/h

[**Note:** D<sub>av</sub> is changed to align with AIS-102 and FAME incentive notification S.O.830(E)]

3.4.5. The electric energy consumption values shall be:

Equation 13:

$$E_1 = e_1 / D_{test1} \text{ and}$$

Equation 14:

$$E_4 = \frac{e_2}{D_{test2}}$$

(Wh/km)

with D<sub>test1</sub> and D<sub>test2</sub> the actual distances driven in the tests performed under Conditions A (clause 3.2 of this Appendix) and B (clause 3.3 of this Appendix) respectively, and e<sub>1</sub> and e<sub>4</sub> determined in clauses 3.2.5. and 3.3.6 of this Appendix respectively.

3.4.6. The weighted electric energy consumption values shall be calculated as follows:

3.4.6.1 For testing in accordance with clause 3.2.3.2.1 of this Appendix;

Equation 15:

$$E = \frac{D_e \cdot E_1 + D_{av} \cdot E_4}{D_e + D_{av}}$$

where:

E = electric consumption Wh/km,

E<sub>1</sub> = electric consumption Wh/km with a fully charged electrical energy device/REESS,

E<sub>4</sub> = electric consumption Wh/km with an electrical energy device/REESS in minimum state of charge (maximum discharge of capacity),

D<sub>e</sub> = electric range of the vehicle determined according to the procedure described in Appendix 1.3. of chapter 9, where the manufacturer shall provide the means for performing the measurement with the vehicle running in pure electric operating state,

D<sub>av</sub> = average distance between two battery recharges,

D<sub>av</sub> = :

25 km for an L5-category vehicle with an engine capacity of < 150 cm<sup>3</sup>;

25 km for an L5-category vehicle with an engine capacity of ≥ 150 cm<sup>3</sup> and v max < 130 km/h;

25 km for an L5-category vehicle with an engine capacity of ≥ 150 cm<sup>3</sup> and v max ≥ 130 km/h.

[**Note:** D<sub>av</sub> is changed to align with AIS-102 and FAME incentive notification S.O.830(E)]

3.4.6.2. For testing in accordance with clause 3.2.3.2.2 of this Appendix

Equation 16:

$$E = \frac{D_{OVC} \cdot E_1 + D_{av} \cdot E_4}{D_{OVC} + D_{av}}$$

where:

E = electric consumption Wh/km,

E<sub>1</sub> = electric consumption Wh/km with a fully charged electrical energy device/REESS,

$E_4$  = electric consumption Wh/km with an electrical energy device/REESS in minimum state of charge (maximum discharge of capacity),

$D_{ovc}$  = OVC range according to the procedure described in Appendix 1.3.

$D_{av}$  = average distance between two battery recharges,

$D_{av}$  = :

25 km for an L5-category vehicle with an engine capacity of  $< 150 \text{ cm}^3$ ;

25 km for an L5-category vehicle with an engine capacity of  $\geq 150 \text{ cm}^3$  and  $v_{\text{max}} < 130 \text{ km/h}$ ;

25 km for an L5-category vehicle with an engine capacity of  $\geq 150 \text{ cm}^3$  and  $v_{\text{max}} \geq 130 \text{ km/h}$ .

[**Note:**  $D_{av}$  is changed to align with AIS-102 and FAME incentive notification S.O.830(E)]

#### **4.0 EXTERNALLY CHARGEABLE (OVC HEV) WITH AN OPERATING MODE SWITCH**

4.1 Two tests shall be performed under the following conditions:

4.1.1. **Condition A:** test carried out with a fully charged electrical energy device/REESS.

4.1.2. **Condition B:** test carried out with an electrical energy device/REESS in minimum state of charge (maximum discharge of capacity).

4.1.3. The operating mode switch shall be positioned in accordance with Table 2, clause 3.2.1.3. of Appendix 11 of chapter 2.

4.2. **Condition A**

4.2.1 If the electric range of the vehicle, as measured in accordance with Appendix 1.3. of this chapter, is higher than one complete cycle, the Type I test for electric energy measurement may be carried out in pure electric mode at the request of the manufacturer after agreement of the test agency and to the satisfaction of the test agency. In this case, the values of  $M_1$  and  $C_1$  in clause 4.4. shall be taken as equal to 0.

4.2.2. The procedure shall start with the discharge of the electrical energy device/REESS of the vehicle as described in clause 4.2.2.1 of this Appendix

4.2.2.1. The electrical energy device/REESS of the vehicle is discharged while driving with the switch in pure electric position (on the test track, on a chassis dynamometer, etc.) at a steady speed of 70 percent  $\pm 5$  percent of the maximum design vehicle speed in pure electric mode, determined in accordance with the test procedure to measure the maximum design vehicle speed set out in AIS-137 – Part 5.

Discharge shall stop in any of the following conditions:

- when the vehicle is unable to run at 65 percent of the maximum thirty minutes speed,
- when the standard on-board instrumentation indicates that the vehicle should be stopped,
- after 100 km.
- If the vehicle is not equipped with a pure electric mode, the electrical energy device/REESS shall be discharged by driving the vehicle (on the test track, on a chassis dynamometer, etc.) at any of the following conditions:
  - at a steady speed of 50 km/h until the fuel-consuming engine starts up,
  - if a vehicle cannot reach a steady speed of 50 km/h without the fuel-consuming engine starting up, the speed shall be reduced until it can run at a lower steady speed at which the fuel-consuming engine does not start up for a defined time or distance (to be determined by the test agency and the manufacturer to the satisfaction of the test agency),
  - in accordance with the manufacturer's recommendation.

The fuel-consuming engine shall be stopped within ten seconds of being automatically started. By means of derogation if the manufacturer can prove to the test agency to the satisfaction of the test agency that the vehicle is physically not capable of achieving the thirty minutes speed the maximum fifteen minute speed may be used instead.

4.2.3. Conditioning of the vehicle

4.2.3.1. The test vehicle shall be preconditioned by conducting the applicable Type I test cycle in combination with the applicable gear-shifting prescriptions in clause 4.4.4.2.3 of chapter 2.

4.2.3.2. After this preconditioning and before testing, the vehicle shall be kept in a room in which the temperature remains relatively constant between 293.3K and 303.3K (20 °C and 30 °C). This conditioning shall be carried out for at least six hours and continue until the temperatures of the engine oil and coolant, if any, are within  $\pm 2\text{K}$  ( $\pm 2^{\circ}\text{C}$ ) of the temperature of the room, and the electrical energy device/REESS is fully charged as a result of the charging prescribed in clause 4.2.3.3 of this Appendix.

4.2.3.3. During soak, the electrical energy device/REESS shall be charged using the normal overnight charging procedure as defined in clause 3.2.2.4 of this Appendix

4.2.4. Test procedure

4.2.4.1. The vehicle shall be started up by the means provided for normal use by the driver. The first cycle starts on the initiation of the vehicle start-up procedure.

4.2.4.2. The test procedures defined in either clause 4.2.4.2.1. or 4.2.4.2.2 of this Appendix may be used

- 4.2.4.2.1. Sampling shall begin (BS) before or at the initiation of the vehicle start-up procedure and end on conclusion of the final idling period in the applicable Type I driving cycle (end of sampling (ES)).
- 4.2.4.2.2. Sampling shall begin (BS) before or at the initiation of the vehicle start-up procedure and continue over a number of repeat test cycles. It shall end on conclusion of the applicable Type I driving cycle during which the battery reached the minimum state of charge in accordance with the following procedure (end of sampling (ES)):
  - 4.2.4.2.2.1 the electricity balance Q (Ah) is measured over each combined cycle, using the procedure in Appendix 1.2., and used to determine when the battery's minimum state of charge has been reached
  - 4.2.4.2.2.2 The battery's minimum state of charge is considered to have been reached in combined cycle N if the electricity balance measured during combined cycle N + 1 is not more than a 3 percent discharge, expressed as a percentage of the nominal capacity of the battery (in Ah) in its maximum state of charge, as declared by the manufacturer. At the manufacturer's request, additional test cycles may be run and their results included in the calculations in clauses 4.2.4.5. and 4.4. of this Appendix, provided that the electricity balance for each additional test cycle shows less discharge of the [battery than over the previous cycle.
  - 4.2.4.2.2.3. between each pair of cycles, a hot soak period of up to ten minutes is allowed. The power train shall be switched off during this period.
- 4.2.4.3. The vehicle shall be driven using the applicable driving cycle and gear-shifting prescriptions as defined in appendix 8 to chapter 2.
- 4.2.4.4. The exhaust gases shall be analyzed according to chapter 2 in force at the time of approval of the vehicle.
- 4.2.4.5. The CO<sub>2</sub> emission and fuel consumption results on the test cycle for Condition A shall be recorded (m<sub>1</sub> (g) and c<sub>1</sub> (l) respectively). In the case of testing in accordance with clause 4.2.4.2.1 of this Appendix, m<sub>1</sub> and c<sub>1</sub> are the results of the single combined cycle run. In the case of testing in accordance with clause 4.2.4.2.2 of this Appendix m<sub>1</sub> and c<sub>1</sub> are the sums of the results of the N combined cycles run:

Equation 17:

$$m_1 = \sum_1^N m_i$$

Equation 18:

$$C_1 = \sum_1^N c_i$$

- 4.2.5. Within 30 minutes of the end of the cycle, the electrical energy device/REESS shall be charged in accordance with clause 3.2.2.4 of this Appendix.

The energy measurement equipment, placed between the mains socket and the vehicle charger, shall measure the energy charge e<sub>1</sub> (Wh) delivered from the mains.

- 4.2.6 The electric energy consumption for Condition A shall be e<sub>1</sub> (Wh).



### 4.3. Condition B

#### 4.3.1. Conditioning of the vehicle

4.3.1.1. The electrical energy device/REESS of the vehicle shall be discharged in accordance with clause 4.2.2.1 of this Appendix.

At the manufacturer's request, conditioning in accordance with clause 4.2.3.1 of this Appendix may be carried out before electrical energy/power storage discharge.

4.3.1.2. Before testing, the vehicle shall be kept in a room in which the temperature shall remain relatively constant between 293.3K and 303.3K (20 °C and 30 °C). This conditioning shall be carried out for at least six hours and continue until the temperatures of the engine oil and coolant, if any, are within  $\pm 2^{\circ}\text{C}$  of the temperature of the room.

#### 4.3.2. Test procedure

4.3.2.1. The vehicle shall be started up by the means provided for normal use by the driver. The first cycle starts on the initiation of the vehicle start-up procedure.

4.3.2.2. Sampling shall begin (BS) before or at the initiation of the vehicle start-up procedure and end on conclusion of the final idling period in the applicable Type I driving cycle (end of sampling (ES)).

4.3.2.3. The vehicle shall be driven using the applicable driving cycle and gear-shifting prescriptions as defined in Appendix 8 to chapter 2.

4.3.2.4. The exhaust gases shall be analyzed in accordance with the provisions of chapter 2 in force at the time of approval of the vehicle.

4.3.2.5. The CO<sub>2</sub> emission and fuel consumption results on the test cycle(s) for Condition B shall be recorded ( $m_2$  (g) and  $c_2$  (l) respectively).

4.3.3. Within 30 minutes of the end of the cycle, the electrical energy device/REESS shall be charged in accordance with clause 3.2.2.4 of this Appendix.

The energy measurement equipment, placed between the mains socket and the vehicle charger, shall measure the energy charge  $e_2$  (Wh) delivered from the mains.

4.3.4. The electrical energy device/REESS of the vehicle shall be discharged in accordance with clause 4.2.2.1 of this Appendix

4.3.5. Within 30 minutes of the discharge, the electrical energy device/REESS shall be charged in accordance with clause 3.2.2.4 of this Appendix. The energy measurement equipment, placed between the mains socket and the vehicle charger, shall measure the energy charge  $e_3$  (Wh) delivered from the mains.

4.3.6. The electric energy consumption  $e_4$  (Wh) for Condition B shall be:

Equation 19:

$$e_4 = e_2 - e_3$$

4.4. **Test results**

4.4.1. The CO<sub>2</sub> values shall be:

Equation 20:

$$M_1 = \frac{m_1}{D_{test1}} \dots \dots \dots \frac{g}{km} \text{ and}$$

Equation 21:

$$M_2 = \frac{m_2}{D_{test2}} \dots \dots \dots (g/km)$$

where:

D<sub>test1</sub> and D<sub>test2</sub> = the actual distances driven in the tests performed under Conditions A (clause 4.2 of this Appendix) and B (clause 4.3 of this Appendix) respectively, and

m<sub>1</sub> and m<sub>2</sub> = test results determined in clauses 4.2.4.5. and 4.3.2.5 of this Appendix respectively

4.4.2. The weighted CO<sub>2</sub> values shall be calculated as follows:

4.4.2.1. For testing in accordance with clause 4.2.4.2.1 of this Appendix:

For reporting, the CO<sub>2</sub> values shall be calculated as in the Equation 7 of this Appendix

4.4.2.2. For testing in accordance with clause 4.2.4.2.2 of this Appendix:

For reporting, the CO<sub>2</sub> values shall be calculated as in the Equation 7 of this Appendix.

4.4.3. The fuel consumption values shall be:

Equation 24:

$$C_1 = \frac{100 * c_1}{D_{test1}}$$

Equation 25:

$$C_2 = \frac{100 * c_2}{D_{test2}} (l/100km)$$

where:

D<sub>test1</sub> and D<sub>test2</sub> = the actual distances driven in the tests performed under Conditions A (clause 4.2.) and B (clause 4.3.) respectively.

C<sub>1</sub> and C<sub>2</sub> = test results determined in clauses 4.2.4.5. and 4.3.2.5 of this Appendix respectively.

4.4.4. The weighted fuel consumption values shall be calculated as follows:

4.4.4.1. For testing in accordance with clause 4.2.4.2.1 of this Appendix:

Equation 26:

$$C = \frac{D_e \cdot C_1 + D_{av} \cdot C_2}{D_e + D_{av}}$$

where:

C = fuel consumption in l/100 km,

C<sub>1</sub> = fuel consumption in l/100 km with a fully charged electrical energy device/REESS,

- $C_2$  = fuel consumption in l/100 km with an electrical energy device/REESS in minimum state of charge (maximum discharge of capacity),
- $D_e$  = electric range of the vehicle determined according to the procedure described in Appendix 1.3., where the manufacturer shall provide the means for performing the measurement with the vehicle running in pure electric operating state,
- $D_{av}$  = average distance between two battery recharges,
- $D_{av}$  = :
- 25 km for an L5-category vehicle with an engine capacity of  $< 150 \text{ cm}^3$ ;
- 25 km for an L5-category vehicle with an engine capacity of  $\geq 150 \text{ cm}^3$  and  $v \text{ max} < 130 \text{ km/h}$ ;
- 25 km for an L5-category vehicle with an engine capacity of  $\geq 150 \text{ cm}^3$  and  $v \text{ max} \geq 130 \text{ km/h}$ .

4.4.4.2. For testing in accordance with clause 4.2.4.2.2 of this Appendix:

Equation 27:

$$C = \frac{D_{OVC} \cdot C_1 + D_{av} \cdot C_2}{D_{OVC} + D_{av}}$$

where:

- $C$  = fuel consumption in l/100 km,
- $C_1$  = fuel consumption in l/100 km with a fully charged electrical energy device/REESS,
- $C_2$  = fuel consumption in l/100 km with an electrical energy device/REESS in minimum state of charge (maximum discharge of capacity),
- $D_{ovc}$  = OVC range according to the procedure described in Appendix 1.3,
- $D_{av}$  = average distance between two battery recharges,
- $D_{av}$  = :
- 25 km for an L5-category vehicle with an engine capacity of  $< 150 \text{ cm}^3$ ;
- 25 km for an L5-category vehicle with an engine capacity of  $\geq 150 \text{ cm}^3$  and  $v \text{ max} < 130 \text{ km/h}$ ;
- 25 km for an L5-category vehicle with an engine capacity of  $\geq 150 \text{ cm}^3$  and  $v \text{ max} \geq 130 \text{ km/h}$ .

4.4.5. The electric energy consumption values shall be:

Equation 28:

$$E_1 = \frac{e_1}{D_{test1}} \text{ and}$$

Equation 29:

$$E_4 = \frac{e_2}{D_{\text{test2}}} \text{ Wh/km}$$

where:

$D_{\text{test1}}$  and  $D_{\text{test2}}$  = the actual distances driven in the tests performed under Conditions A (clause 4.2.) and B (clause 4.3.) respectively, and

$e_1$  and  $e_4$  = test results determined in clauses 4.2.6. and 4.3.6 of this Appendix respectively

4.4.6. The weighted electric energy consumption values shall be calculated as follows:

4.4.6.1. For testing in accordance with clause 4.2.4.2.1 of this Appendix:

Equation 30:

$$E = \frac{D_e \cdot E_1 + D_{av} \cdot E_4}{D_e + D_{av}}$$

where:

$E$  = electric consumption Wh/km,

$E_1$  = electric consumption Wh/km with a fully charged electrical energy device/REESS,

$E_4$  = electric consumption Wh/km with an electrical energy device/REESS in minimum state of charge (maximum discharge of capacity),

$D_e$  = electric range of the vehicle determined according to the procedure described in Appendix 1, where the manufacturer shall provide the means for performing the measurement with the vehicle running in pure electric operating state,

$D_{av}$  = average distance between two battery recharges,

$D_{av}$  = :

25 km for an L5-category vehicle with an engine capacity of < 150 cm<sup>3</sup>;

25 km for an L5-category vehicle with an engine capacity of ≥ 150 cm<sup>3</sup> and  $v_{\text{max}} < 130$  km/h;

25 km for an L5-category vehicle with an engine capacity of ≥ 150 cm<sup>3</sup> and  $v_{\text{max}} \geq 130$  km/h.

4.4.6.2. For testing in accordance with clause 4.2.4.2.2 of this Appendix:

Equation 31:

$$E = \frac{D_{OVC} \cdot E_1 + D_{av} \cdot E_4}{D_{OVC} + D_{av}}$$

where:

$E$  = electric consumption Wh/km,

$E_1$  = electric consumption Wh/km with a fully charged electrical energy/ power storage device,

$E_4$  = electric consumption Wh/km with an electrical energy device / REESS in minimum state of charge (maximum discharge of capacity),

$D_{ovc}$  = OVC range according to the procedure described in Appendix 1.3.,

$D_{av}$  = average distance between two battery recharges,

$D_{av}$  = :

25 km for an L5-category vehicle with an engine capacity of < 150 cm<sup>3</sup> ;

25 km for an L5-category vehicle with an engine capacity of  $\geq$  150 cm<sup>3</sup> and  $v_{max} < 130$  km/h;

25 km for an L5-category vehicle with an engine capacity of  $\geq$  150 cm<sup>3</sup> and  $v_{max} \geq 130$  km/h.

[**Note:**  $D_{av}$  is changed tso align with AIS-102 and FAME incentive notification S.O.830(E)]

**5.0 NOT EXTERNALLY CHARGEABLE HYBRID ELECTRIC VEHICLE (NOVC HEV) WITHOUT AN OPERATING MODE SWITCH**

5.1. The test vehicle shall be preconditioned by conducting the applicable Type I test cycle in combination with the applicable gear-shifting prescriptions in clause 4.5.5. of Chapter 2.

5.1.1. Carbon dioxide (CO<sub>2</sub>) emissions and fuel consumption shall be determined separately for parts 1, 2 and 3, if applicable, of the applicable driving cycle in Appendix 6 to Chapter 2.

5.2. For preconditioning, at least two consecutive complete driving cycles shall be carried out without intermediate soak, using the applicable driving cycle and gear-shifting prescriptions set out in clause 4.4.4.2.3. of Chapter 2.

5.3. Test results

5.3.1. The test results (fuel consumption C (l/100 km for liquid fuels or kg/100 km for gaseous fuels) and CO<sub>2</sub> - emission M (g/km)) of this test shall be corrected in line with the energy balance  $\Delta E_{batt}$  of the battery of the vehicle.

The corrected values  $C_0$  (l/100 km or kg/100 km) and  $M_0$  (g/km) shall correspond to a zero energy balance ( $\Delta E_{batt} = 0$ ) and shall be calculated using a correction coefficient determined by the manufacturer for storage systems other than electric batteries as follows:  $\Delta E_{batt}$  shall represent  $\Delta E_{storage}$ , the energy balance of the electric energy storage device.

5.3.1.1. The electricity balance  $Q$  (Ah), measured using the procedure in Appendix 1.2. to this Appendix, shall be used as a measure of the difference between the vehicle battery's energy content at the end of the cycle and that at the beginning of the cycle. The electricity balance is to be determined separately for the individual clause 1, 2 and 3, if applicable, of the Type I test cycle in Appendix 6 of Chapter 2.

5.3.2. the uncorrected measured values  $C$  and  $M$  may be taken as the test results under the following conditions:

- (a) the manufacturer can demonstrate to the satisfaction of the test agency that there is no relation between the energy balance and fuel consumption,
- (b)  $\Delta E_{batt}$  always corresponds to a battery charging,
- (c)  $\Delta E_{batt}$  always corresponds to a battery discharging and  $\Delta E_{batt}$  is within 1 percent of the energy content of the consumed fuel (i.e. the total fuel consumption over one cycle).

The change in battery energy content  $\Delta E_{batt}$  shall be calculated from the measured electricity balance  $Q$  as follows:

Equation 32:

$$\begin{aligned} \Delta E_{batt} &= \Delta SOC(\text{percent}) \cdot E_{TEbatt} = 0.0036 * |\Delta Ah| * V_{batt} \\ &= 0.0036 * Q * V_{batt} \quad (MJ) \end{aligned}$$

where:

$E_{TEbatt}$  = the total energy storage capacity of the battery (MJ) and

$V_{batt}$  = the nominal battery voltage (V).

5.3.3. Fuel consumption correction coefficient ( $K_{fuel}$ ) defined by the manufacturer

5.3.3.1. The fuel consumption correction coefficient ( $K_{fuel}$ ) shall be determined from a set of  $n$  measurements, which shall contain at least one measurement with  $Q_i < 0$  and at least one with  $Q_j > 0$ .

If this second measurement cannot be taken on the applicable test Type I driving cycle used in this test, the test agency shall judge the statistical significance of the extrapolation necessary to determine the fuel consumption value at  $\Delta E_{batt} = 0$  to the satisfaction of the test agency

5.3.3.2. The fuel consumption correction coefficient ( $K_{fuel}$ ) shall be defined as:

Equation 33:

$$K_{fuel} = \frac{(n \cdot \sum Q_i C_i - \sum Q_i * \sum C_i)}{(n \cdot \sum Q_i^2 - (\sum Q_i)^2)} \quad (l/100km/Ah)$$

where:

$C_i$  = fuel consumption measured during i-th manufacturer's test (l/100 km or kg/100km),

$Q_i$  = electricity balance measured during i-th manufacturer's test (Ah),

$n$  = number of data.

The fuel consumption correction coefficient shall be rounded to four significant figures (e.g. 0.xxxx or xx.xx). The test agency shall judge the statistical significance of the fuel consumption correction coefficient to the satisfaction of the test agency .

5.3.3.3. Separate fuel consumption correction coefficients shall be determined for the fuel consumption values measured Type I test cycle in Appendix 6 to Chapter 2.

5.3.4. Fuel consumption at zero battery energy balance ( $C_0$ )

5.3.4.1. Fuel consumption  $C_0$  at  $\Delta E_{batt} = 0$  is determined by the following equation:

Equation 34:

$$C_0 = C - K_{fuel} \cdot Q \text{ (l/100 km or kg/100 km)}$$

where:

$C$  = fuel consumption measured during test (l/100 km for liquid fuels and kg/100 km for gaseous fuels),

$Q$  = electricity balance measured during test (Ah).

5.3.4.2. Fuel consumption at zero battery energy balance shall be determined separately for the fuel consumption values measured Type I test cycle in Chapter 2

5.3.5.  $CO_2$  - emission correction coefficient ( $K_{CO_2}$ ) defined by the manufacturer

5.3.5.1. The  $CO_2$  -emission correction coefficient ( $K_{CO_2}$ ) shall be determined as follows from a set of  $n$  measurements, which shall contain at least one measurement with  $Q_i < 0$  and at least one with  $Q_j > 0$ .

If this second measurement cannot be taken on the driving cycle used in this test, the test agency shall judge the statistical significance of the extrapolation necessary to determine the  $CO_2$  -emission value at  $\Delta E_{batt} = 0$  to the satisfaction of the test agency.

5.3.5.2. The  $CO_2$  -emission correction coefficient ( $K_{CO_2}$ ) is defined as:

Equation 35:

$$K_{CO_2} = \frac{(n \cdot \sum Q_i M_i - \sum Q_i * \sum M_i)}{(n \cdot \sum Q_i^2 - (\sum Q_i)^2)} \text{ g/km/Ah}$$

where:

$M_i$  = CO<sub>2</sub> -emission measured during  $i^{\text{th}}$  manufacturer's test (g/km),

$Q_i$  = electricity balance during  $i^{\text{th}}$  manufacturer's test (Ah),

$n$  = number of data.

The CO<sub>2</sub> -emission correction coefficient shall be rounded to four significant figures (e.g. 0.xxxx or xx.xx). The test agency shall judge the statistical significance of the CO<sub>2</sub> -emission correction coefficient to the satisfaction of the test agency.

5.3.5.3. Separate CO<sub>2</sub> -emission correction coefficients shall be determined for the fuel consumption values driving cycle in Appendix 6 of Chapter 2.

5.3.6. CO<sub>2</sub> -emission at zero battery energy balance ( $M_0$ )

5.3.6.1. The CO<sub>2</sub> -emission  $M_0$  at  $\Delta E_{\text{batt}} = 0$  is determined by the following equation:

Equation 36:

$$M_0 = M - K_{CO_2} \cdot Q \text{ (g/km)}$$

where:

$C$  = fuel consumption measured during test (l/100 km for liquid fuels and kg/100 km for gaseous fuels),

$Q$  = electricity balance measured during test (Ah).

5.3.6.2. CO<sub>2</sub> emissions at zero battery energy balance shall be determined separately for the CO<sub>2</sub> emission values measured Type I test cycle set out in Appendix 6 to Chapter 2.

## **6.0 NOT EXTERNALLY CHARGEABLE (NOT OVC HEV) WITH AN OPERATING MODE SWITCH**

6.1. These vehicles shall be tested in hybrid mode in accordance with Appendix 1, using the applicable driving cycle and gear-shifting prescriptions in clause 4.5.5. of Chapter 2. If several hybrid modes are available, the test shall be carried out in the mode that is automatically set after the ignition key is turned on (normal mode).

6.1.1. Carbon dioxide (CO<sub>2</sub>) emissions and fuel consumption shall be determined separately for parts 1, 2 and 3 of the Type I test cycle in Appendix 6 of Chapter 2.

6.2. For preconditioning, at least two consecutive complete driving cycles shall be carried out without intermediate soak, using the applicable Type I test cycle and gear-shifting prescriptions in Appendix 6 of Chapter 2.

6.3. Test results

6.3.1. The fuel consumption  $C$  (l/100 km) and CO<sub>2</sub> -emission  $M$  (g/km)) results of this test shall be corrected in line with the energy balance  $\Delta E_{\text{batt}}$  of the battery of the vehicle



The corrected values ( $C_0$  (l/100 km for liquid fuels or kg/100 km for gaseous fuels) and  $M_0$  (g/km)) shall correspond to a zero energy balance ( $\Delta E_{\text{batt}} = 0$ ), and are to be calculated using a correction coefficient determined by the manufacturer as defined in clause 6.3.3 and 6.3.5 of this appendix.

For storage systems other than electric batteries,  $\Delta E_{\text{batt}}$  shall represent  $\Delta E_{\text{storage}}$ , the energy balance of the electric energy storage device.

6.3.1.1. The electricity balance  $Q$  (Ah), measured using the procedure in Appendix 1.2., shall be used as a measure of the difference between the vehicle battery's energy content at the end of the cycle and that at the beginning of the cycle. The electricity balance is to be determined separately for parts 1, 2 and 3 of the applicable Type I test cycle set out in Appendix 6 of Chapter 2

6.3.2. The uncorrected measured values  $C$  and  $M$  may be taken as the test results under the following conditions:

- (a) the manufacturer can prove that there is no relation between the energy balance and fuel consumption,
- (b)  $\Delta E_{\text{batt}}$  always corresponds to a battery charging,
- (c)  $\Delta E_{\text{batt}}$  always corresponds to a battery discharging and  $\Delta E_{\text{batt}}$  is within 1 percent of the energy content of the consumed fuel (i.e. the total fuel consumption over one cycle).

The change in battery energy content  $\Delta E_{\text{batt}}$  can be calculated from the measured electricity balance  $Q$  as follows:

Equation 37:

$$\Delta E_{\text{batt}} = \Delta \text{SOC (percent)} \cdot E_{\text{TEbatt}} \equiv 0.0036 \cdot |\Delta \text{Ah}| \cdot V_{\text{batt}} \equiv 0.0036 \cdot Q \cdot V_{\text{batt}} \text{ (MJ)}$$

where:

$E_{\text{TEbatt}}$  = the total energy storage capacity of the battery (MJ), and

$V_{\text{batt}}$  = the nominal battery voltage (V).

6.3.3. Fuel consumption correction coefficient ( $K_{\text{fuel}}$ ) defined by the manufacturer

6.3.3.1. The fuel consumption correction coefficient ( $K_{\text{fuel}}$ ) shall be determined from a set of  $n$  measurements, which shall contain at least one measurement with  $Q_i < 0$  and at least one with  $Q_j > 0$ .

If this second measurement cannot be taken on the driving cycle used in this test, the test agency shall judge the statistical significance of the extrapolation necessary to determine the fuel consumption value at  $\Delta E_{\text{batt}} = 0$  to the satisfaction of the test agency.

6.3.3.2. The fuel consumption correction coefficient ( $K_{\text{fuel}}$ ) shall be defined as:

Equation 38:

$$K_{\text{fuel}} = \frac{(n \cdot \sum Q_i C_i - \sum Q_i * \sum C_i)}{(n \cdot \sum Q_i^2 - (\sum Q_i)^2)} \text{ (l/100km/Ah)}$$

where:

$C_i$  = fuel consumption measured during  $i^{\text{th}}$  manufacturer's test (l/100 km for liquid fuels and kg/100 km for gaseous fuels)

$Q_i$  = electricity balance measured during  $i$ -th manufacturer's test (Ah)

$n$  = number of data

The fuel consumption correction coefficient shall be rounded to four significant figures (e.g. 0.xxxx or xx.xx). The statistical significance of the fuel consumption correction coefficient shall be judged by the test agency.

6.3.3.3. Separate fuel consumption correction coefficients shall be determined for the fuel consumption values measured Type I test cycle set out in Chapter 2.

6.3.4. Fuel consumption at zero battery energy balance ( $C_0$ )

6.3.4.1. The fuel consumption  $C_0$  at  $\Delta E_{\text{batt}} = 0$  is determined by the following equation:

Equation 39:

$C_0 = C - K_{\text{fuel}} \cdot Q$  (in l/100 km for liquid fuels and kg/100 km for gaseous fuels)

where:

$C$  = fuel consumption measured during test (in l/100 km or kg/100 km)

$Q$  = electricity balance measured during test (Ah)

6.3.4.2. Fuel consumption at zero battery energy balance shall be determined separately for the fuel consumption values measured Type I test cycle set out in Chapter 2.

6.3.5.  $\text{CO}_2$  - emission correction coefficient ( $K_{\text{CO}_2}$ ) defined by the manufacturer

6.3.5.1. The  $\text{CO}_2$  -emission correction coefficient ( $K_{\text{CO}_2}$ ) shall be determined as follows from a set of  $n$  measurements. This set shall contain at least one measurement with  $Q_i < 0$  and one with  $Q_j > 0$ .

If this second measurement cannot be taken on the Type I test cycle used in this test, the test agency shall judge the statistical significance of the extrapolation necessary to determine the  $\text{CO}_2$  -emission value at  $\Delta E_{\text{batt}} = 0$  to the satisfaction of the Test Agency.

6.3.5.2. The  $\text{CO}_2$ -emission correction coefficient ( $K_{\text{CO}_2}$ ) shall be defined as:

Equation 40:

$K_{\text{CO}_2} = (n \sum Q_i M_i - \sum Q_i \cdot \sum M_i) / (n \cdot \sum Q_i^2 - (\sum Q_i)^2)$  in (g/km/Ah)

where:

$M_i$  =  $\text{CO}_2$ -emission measured during  $i^{\text{th}}$  manufacturer's test (g/km)

$Q_i$  = electricity balance during  $i^{\text{th}}$  manufacturer's test (Ah)

$N$  = number of data

The CO<sub>2</sub>-emission correction coefficient shall be rounded to four significant figures (e.g. 0.xxxx or xx.xx). The statistical significance of the CO<sub>2</sub>-emission correction coefficient shall be judged by the test agency.

6.3.5.3. Separate CO<sub>2</sub>-emission correction coefficients shall be determined for the fuel consumption values measured Type I test cycle

6.3.6. CO<sub>2</sub>emission at zero battery energy balance (M<sub>0</sub> )

6.3.6.1. The CO<sub>2</sub> emission M<sub>0</sub> at  $\Delta E_{\text{batt}} = 0$  is determined by the following equation:

Equation 41:

$$M_0 = M - K_{CO_2} \cdot Q \text{ in (g/km)}$$

where:

C: fuel consumption measured during test (l/100 km)

Q: electricity balance measured during test (Ah)

6.3.6.2 CO<sub>2</sub> emission at zero battery energy balance shall be determined separately for the CO<sub>2</sub> -emission values measured Type I test cycle set out in Appendix 6 of Chapter 2.

**APPENDIX 1.1 TO CHAPTER 9**

**ELECTRICAL ENERGY DEVICE/REESS STATE OF CHARGE (SOC) PROFILE FOR AN EXTERNALLY CHARGEABLE HYBRID ELECTRIC VEHICLE (OVC HEV) IN A TYPE VII TEST**

**1.0 STATE OF CHARGE (SOC) PROFILE FOR OVC HEV TYPE VII TEST**

The SOC profiles for OVC-HEVs tested under Conditions A and B of the test Type VII shall be:

**1.1. Condition A:**

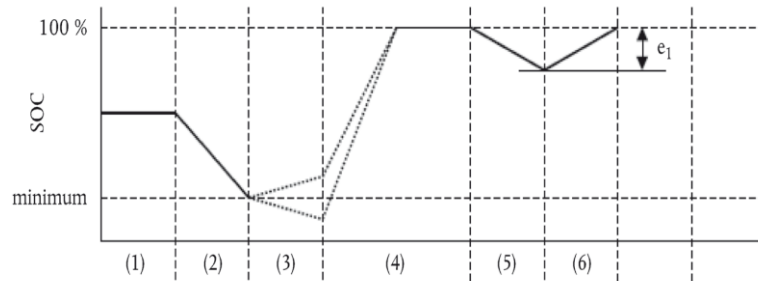

**Figure 1**  
**Condition A of the Type VII test**

- (1) initial state of charge of the electrical energy device/REESS;
- (2) discharge in accordance with clause 3.2.1. or 4.2.2. of Appendix 1;
- (3) vehicle conditioning in accordance with clause 3.2.2. or 4.2.3. of Appendix 1;
- (4) charge during soak in accordance with clause 3.2.2.3. and 3.2.2.4. or 4.2.3.2. and 4.2.3.3. of Appendix 1;
- (5) test in accordance with clause 3.2.3. or 4.2.4. of Appendix 1;
- (6) charging in accordance with clause 3.2.4. or 4.2.5. of Appendix 1;

**1.2 Condition B:**

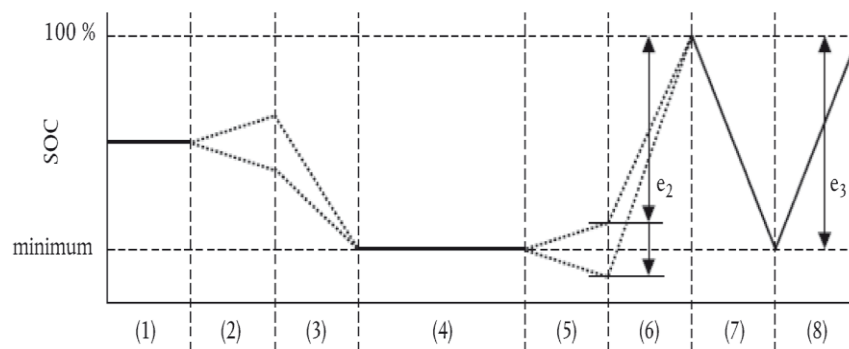

**Figure 2**  
**Condition B of the Type VII test**

- (1) initial state of charge;
- (2) vehicle conditioning in accordance with clause 3.3.1.1. or 4.3.1.1. (optional) of Appendix 1;
- (3) discharge in accordance with clause 3.3.1.1. or 4.3.1.1. of Appendix 1;
- (4) soak in accordance with clause 3.3.1.2. or 4.3.1.2. of Appendix 1;
- (5) test in accordance with clause 3.3.2. or 4.3.2. of Appendix 1;
- (6) charging in accordance with clause 3.3.3. or 4.3.3. of Appendix 1;
- (7) discharging in accordance with clause 3.3.4. or 4.3.4. of Appendix 1;
- (8) charging in accordance with clause 3.3.5. or 4.3.5. of Appendix 1;

**APPENDIX 1.2 TO CHAPTER 9  
METHOD FOR MEASURING THE ELECTRICITY BALANCE OF THE  
BATTERY OF OVC AND NOVC HEV**

**1.0 INTRODUCTION**

1.1 This Appendix sets out the method and required instrumentation for measuring the electricity balance of Off- vehicle Charging Hybrid Electric Vehicles (OVC HEV) and Not-Off-vehicle Charging Hybrid Electric Vehicles (NOVC HEV). Measurement of the electricity balance is necessary

- (a) to determine when the battery's minimum state of charge has been reached during the test procedure in clauses 3.3 and 4.3 of Appendix 1, and
- (b) to adjust the fuel consumption and CO<sub>2</sub> -emissions measurements in line with the change in battery energy content during the test, using the method in clauses 5.3.1.1. and 6.3.1.1. of Appendix 1.

1.2. The method described in this Appendix shall be used by the manufacturer for taking the measurements to determine the correction factors K fuel and  $K_{CO_2}$ , as defined in clauses 5.3.3.2., 5.3.5.2., 6.3.3.2., and 6.3.5.2. of Appendix 1.

The test agency shall check whether these measurements have been taken in accordance with the procedure described in this Appendix.

1.3. The method described in this Appendix shall be used by the test agency for measuring the electricity balance Q, as defined in the relevant points of Appendix 1.

**2.0 MEASUREMENT EQUIPMENT AND INSTRUMENTATION**

2.1. During the tests described in clauses 3 to 6 of Appendix 1, the battery current shall be measured using a current transducer of the clamp-on or the closed type. The current transducer (i.e. the current sensor without data acquisition equipment) shall have a minimum accuracy of 0.5 percent of the measured value or 0.1 percent of the maximum value of the scale.

Original equipment manufacturer diagnostic testers are not to be used for the purpose of this test.

2.1.1. The current transducer shall be fitted on one of the wires directly connected to the battery. To make it easier to measure the battery current with external equipment, the manufacturer shall integrate appropriate, safe and accessible connection points in the vehicle. If that is not feasible, the manufacturer is obliged to support the test agency by providing the means to connect a current transducer to the wires connected to the battery as described in clause 2.1 of this Appendix.

2.1.2. The output of the current transducer shall be sampled with a minimum sample frequency of 5 Hz. The measured current shall be integrated over time, yielding the measured value of Q, expressed in Ampere hours (Ah).

- 2.1.3. The temperature at the location of the sensor shall be measured and sampled with the same sample frequency as the current, so that this value can be used for possible compensation of the drift of current transducers and, if applicable, the voltage transducer used to convert the output of the current transducer
- 2.2. The test agency shall be provided with a list of the instrumentation (manufacturer, model number, serial number) used by the manufacturer for determining the correction factors  $K_{fuel}$  and  $K_{CO_2out}$  in Appendix 1 and the last calibration dates of the instruments, where applicable.

### **3.0 MEASUREMENT PROCEDURE**

- 3.1. Measurement of the battery current shall start at the beginning of the test and end immediately after the vehicle has driven the complete driving cycle.
- 3.2. Separate values of  $Q$  shall be logged over the parts (cold/warm or phase 1 and, if applicable, phases 2 and 3) of the Type I test cycle set out in Appendix 6 of Chapter 2.

## APPENDIX 1.3 TO CHAPTER 9

### METHOD OF MEASURING THE ELECTRIC RANGE OF VEHICLES POWERED BY A HYBRID ELECTRIC POWERTRAIN AND THE OVC RANGE OF VEHICLES POWERED BY A HYBRID ELECTRIC POWERTRAIN

#### 1.0 MEASUREMENT OF THE ELECTRIC RANGE

The following test method set out in clause 4 shall be used to measure the electric range, expressed in km, of vehicles powered by the electric range and OVC range of vehicles powered by a hybrid electric powertrain with off-vehicle charging (OVC HEV) as defined in this Appendix.

#### 2.0 PARAMETERS, UNITS AND ACCURACY OF MEASUREMENTS

Parameters, units and accuracy of measurements shall be as follows:

<b>Table 1</b>			
<b>Parameters, units and accuracy of measurements</b>			
<b>Parameter</b>	<b>Unit</b>	<b>Accuracy</b>	<b>Resolution</b>
Time	s	$\pm 0.1$ s	0.1 s
Distance	m	$\pm 0.1$ percent	1 m
Temperature	K	$\pm 1$ K	1 K
Speed	km/h	$\pm 1$ percent	0.2 km/h
Mass	kg	$\pm 0.5$ percent	1 kg

#### 3.0 TEST CONDITIONS

##### 3.1. Condition of the vehicle

3.1.1. The vehicle tyres shall be inflated to the pressure specified by the vehicle manufacturer when the tyres are at the ambient temperature.

3.1.2. The viscosity of the oils for the mechanical moving parts shall conform to the vehicle manufacturer's specifications.

3.1.3. The lighting and signaling and auxiliary devices shall be off, except those required for the testing and usual daytime operation of the vehicle.

3.1.4. All energy storage systems for other than traction purposes (electric, hydraulic, pneumatic, etc.) shall be charged to their maximum level as specified by the manufacture

3.1.5. If the batteries are operated above the ambient temperature, the operator shall follow the procedure recommended by the vehicle manufacturer in order to keep the battery temperature in the normal operating range. The manufacturer shall be in a position to attest that the thermal management system of the battery is neither disabled nor reduced.

3.1.6. The vehicle shall have travelled at least 300 km in the seven days before the test with the batteries installed for the test.

3.2. Climatic conditions

For testing performed outdoors, the ambient temperature shall be between 278.3K and 305.3K (5 °C and 32 °C).

The indoor testing shall be performed at a temperature of between 278.3K and 305.3K (2 °C and 30 °C).

#### 4.0 OPERATION MODES

The test method includes the following steps:

- (a) initial charge of the battery;
- (b) application of the cycle and measurement of the electric range.

If the vehicle shall move between the steps, it shall be pushed to the next test area (without regenerative recharging).

4.1. Initial charge of the battery

Charging the battery consists of the following procedure:

4.1.1. The ‘initial charge’ of the battery means the first charge of the battery, on reception of the vehicle. Where several combined tests or measurements are carried out consecutively, the first charge shall be an ‘initial charge’ and the subsequent charges may follow the ‘normal overnight charge’ procedure set out in 3.2.2.4. of Appendix 1.

4.1.2. Discharge of the battery

4.1.2.2. For externally chargeable hybrid electric vehicles (OVC HEV) without an operating mode switch as defined in Appendix 1:

4.1.2.2.1. The manufacturer shall provide the means for taking the measurement with the vehicle running in pure electric operating state.

4.1.2.2.2. The procedure shall start with the discharge of the electrical energy device/REESS of the vehicle while driving (on the test track, on a chassis dynamometer, etc.) in any of the following conditions:

- at a steady speed of 50 km/h until the fuel-consuming engine of the HEV starts up;
- if a vehicle cannot reach a steady speed of 50 km/h without the fuel-consuming engine starting up, the speed shall be reduced until it can run at a lower steady speed at which the fuel-consuming engine does not start up for a defined time or distance (to be determined by the test agency and the manufacturer)
- in accordance with the manufacturer’s recommendation.

The fuel-consuming engine shall be stopped within ten seconds of being automatically started.

4.1.2.3. For externally chargeable hybrid electric vehicles (OVC HEV) with an operating mode switch as defined in Appendix 1:



- 4.1.2.3.1. If the mode switch does not have a pure electric position, the manufacturer shall provide the means for taking the measurement with the vehicle running in pure electric operating state.
- 4.1.2.3.2. The procedure shall start with the discharge of the electrical energy device/REESS of the vehicle while driving with the switch in pure electric position (on the test track, on a chassis dynamometer, etc.) at a steady speed of 70 percent  $\pm$  5 percent of the maximum design vehicle speed of the vehicle in pure electric mode which is to be determined according to the test procedure in Appendix 1 to Chapter 9.

- 4.1.2.3.3. Discharging shall stop in any of the following conditions:
- when the vehicle is unable to run at 65 percent of the maximum thirty minutes speed;
  - when the standard on-board instrumentation indicates that the vehicle should be stopped;
  - after 100 km.

By means of derogation if the manufacturer can prove to the test agency to the satisfaction of the test agency that the vehicle is physically not capable of achieving the thirty minutes speed the maximum fifteen minute speed may be used instead.

- 4.1.2.3.4. If the vehicle is not equipped with a pure electric operating state, the electrical energy device/REESS shall be discharged by driving the vehicle (on the test track, on a chassis dynamometer, etc.):
- at a steady speed of 50 km/h until the fuel-consuming engine of the HEV starts up; or
  - if a vehicle cannot reach a steady speed of 50 km/h without the fuel-consuming engine starting up, the speed shall be reduced until it can run at a lower steady speed at which the fuel-consuming engine does not start up for a defined time or distance (to be determined by the test agency and the manufacturer); or
  - in accordance with the manufacturer's recommendation.

The fuel-consuming engine shall be stopped within ten seconds of being automatically started

4.1.3. Normal overnight charge

For an OVC HEV, the battery shall be charged according to the normal overnight charge procedure as described in clause 3.2.2.4. of Appendix 1

4.2. Application of the cycle and measurement of the range

4.2.2. For hybrid electric vehicles:

- 4.2.2.1.1. The applicable Type I test cycle and accompanying gearshift arrangements, as set out in clause 4.4.4.2.3. of Chapter 2 shall be carried out on a chassis dynamometer adjusted as described in Chapter 2, until the test criteria are m

- 4.2.2.1.2. To measure the electric range, the test criteria shall be deemed as having been met when the vehicle is unable to meet the target curve up to 50 km/h, or when the standard on-board instrumentation indicates that the vehicle should be stopped, or when the battery has reached its minimum state of charge. The vehicle shall then be slowed to 5 km/h without braking by releasing the accelerator pedal, and then stopped by braking.
- 4.2.2.1.3. At speeds of over 50 km/h, when the vehicle does not reach the acceleration or speed required for the test cycle, the accelerator pedal shall remain fully depressed until the reference curve has been reached again
- 4.2.2.1.4. Up to three interruptions, of no more than 15 minutes in total, are permitted between test sequences
- 4.2.2.1.5. The distance covered in km using the electrical motor only ( $D_e$ ) is the electric range of the hybrid electric vehicle. It shall be rounded to the nearest whole number. Where the vehicle operates both in electric and in hybrid mode during the test, the periods of electric-only operation will be determined by measuring current to the injectors or ignition.
- 4.2.2.2. Determining the OVC range of a hybrid electric vehicle
  - 4.2.2.2.1. The applicable Type I test cycle and accompanying gearshift arrangements, as set out in clause 4.4.4.2.3. of Chapter 2, shall be carried out on a chassis dynamometer adjusted as described in 1 2, until the test criteria are met.
  - 4.2.2.2.2. To measure the OVC range  $D_{OVC}$ , the test criteria shall be deemed as having been met when the battery has reached its minimum state of charge according to the criteria in clauses 3.2.3.2.2.2. or 4.2.4.2.2.2. of Appendix 1. Driving shall be continued until the final idling period in the Type I test cycle has been completed.
  - 4.2.2.2.3. Up to three interruptions, of no more than fifteen minutes in total, are permitted between test sequences.
  - 4.2.2.2.4. The total distance driven in km, rounded to the nearest whole number, shall be the OVC range of the hybrid electric vehicle.
  - 4.2.2.3. At speeds of over 50 km/h, when the vehicle does not reach the acceleration or speed required for the test cycle, the accelerator pedal shall remain fully depressed, or the accelerator handle shall be turned fully, until the reference curve has been reached again.
  - 4.2.2.4. Up to three interruptions, of no more than 15 minutes in total, are permitted between test sequences
  - 4.2.2.5. The distance covered in km ( $D_{OVC}$ ) is the electric range of the hybrid electric vehicle. It shall be rounded to the nearest whole number.

<b>ANNEXURE I COMPOSITION OF AISC PANEL*</b>	
<b>Name</b>	
Mr. Dinesh Tyagi	Convener – Director, ICAT International Centre for Automotive Technology, Manesar
<b>Co-ordinator and Member Secretary</b>	
Ms. Vijayanta Ahuja	International Centre for Automotive Technology, Manesar
<b>Members</b>	<b>Representing</b>
Mr. Vikas Sadan	International Centre for Automotive Technology, Manesar
Ms. Sita Kumari	International Centre for Automotive Technology, Manesar
Mr. Deepak Joshi	International Centre for Automotive Technology, Manesar
Mr. Ashish Mallarh	International Centre for Automotive Technology, Manesar
Mr. Vijay Negi	International Centre for Automotive Technology, Manesar
Ms. S.S. Bakle	Automotive Research Association of India
Mr. A. S. Bhale	Automotive Research Association of India
Mr. K.B. Patil	Automotive Research Association of India
Mr. S.S. Sattigeri	Central Institute of Road Transport
Mr. M.K. Chaudhari	Central Institute of Road Transport
Mr. Nilesh Tagad	Central Institute of Road Transport
Mr. A.V. Kumbhar	Society of Indian Automobile Manufacturers
Mr. Deepesh Mutke	Society of Indian Automobile Manufacturers
Mr. S. Sakthivelan	Society of Indian Automobile Manufacturers
Mr. R.S. Prakash	Society of Indian Automobile Manufacturers
Mr. Karan Rajput	Honda Motorcycle and Scooter India Pvt. Ltd.
Mr. Abhay Kumar	Hero MotoCorp Ltd.
Mr. Nagarajan R	TVS Motor Co. Ltd.
Mr. Iranna K.G.	Indian Institute of Petroleum

\* At the time of approval of this Automotive Industry Standard (AIS)

**ANNEXURE II**  
**COMMITTEE COMPOSITION\***  
**Automotive Industry Standards Committee**

<b>Chairperson</b>	
Mrs. Rashmi Urdhwareshe	Director The Automotive Research Association of India, Pune
<b>Members</b>	<b>Representing</b>
Representative from	Ministry of Road Transport and Highways (Dept. of Road Transport and Highways), New Delhi
Representative from	Ministry of Heavy Industries and Public Enterprises (Department of Heavy Industry), New Delhi
Shri S. M. Ahuja	Office of the Development Commissioner, MSME, Ministry of Micro, Small and Medium Enterprises, New Delhi
Shri Shrikant R. Marathe	Former Chairman, AISC
Shri R.R. Singh	Bureau of Indian Standards, New Delhi
Director	Central Institute of Road Transport, Pune
Director	Global Automotive Research Centre, Chennai
Director	International Centre for Automotive Technology, Manesar
Director	Indian Institute of Petroleum, Dehra Dun
Director	Vehicles Research and Development Establishment, Ahmednagar
Director	Indian Rubber Manufacturers Research Association
Representatives from	Society of Indian Automobile Manufacturers
Shri R. P. Vasudevan	Tractor Manufacturers Association, New Delhi
Shri Uday Harite	Automotive Components Manufacturers Association of India, New Delhi

Member Secretary  
Shri Vikram Tandon  
Dy. General Manager  
The Automotive Research Association of India, Pune

\* At the time of approval of this Automotive Industry Standard (AIS)