

Amd 5 to AIS-153 (09/2019)

To Additional Requirements for Bus Construction

1.0 Page 2/58, Clause No. 2.1

Substitute following text for existing text:

2.1 Engine/Electric Traction Motor Power to Gross Vehicle Weight

All buses shall have engine/electric traction motor power to gross vehicle weight ratio greater than 5 kW/ton

2.0 Page 2/58, Clause No. 2.3

Read clause “2.3 Vibration” as “2.4 Vibration” and renumber subsequent clauses.

2.0 Page 16/58, Annexure II,

Add following new clause 6.5 after clause 6.4:

6.5 In case of sleeper buses, the vibration shall be measured at sleeping-berths with the accelerometer positioned at the following three positions:

- i) Driver’s seat;
- ii) Upper and lower berth of middle row of nearest to the transverse and longitudinal axis of the vehicle and;
- iii) Upper and lower berth of the last row of sleeping berth nearest to the longitudinal axis of the vehicle.

3.0 Page 23/58, Annexure III,

Add following new clause 6.4 after clause 6.3

6.4 In case of sleeper buses, the vibration shall be measured at sleeping-berths with the accelerometer positioned at the following three positions:

- i) Driver’s seat;
- ii) Upper and lower berth of middle row of nearest to the transverse and longitudinal axis of the vehicle and;
- iii) Upper and lower berth of the last row of sleeping berth nearest to the longitudinal axis of the vehicle.

4.0 Page 29/58, Annexure IV, Table 1, Sr. No. 12 and 13

Substitute words and figure “ISO 7637:2004” for words “ISO 7637” and substitute words and figure “ISO 7637-2:2004” for words and figures “ISO 7637-2”

PRINTED BY
THE AUTOMOTIVE RESEARCH ASSOCIATION OF INDIA
P. B. NO. 832, PUNE 411 004
ON BEHALF OF
AUTOMOTIVE INDUSTRY STANDARDS COMMITTEE
UNDER
CENTRAL MOTOR VEHICLES RULES - TECHNICAL STANDING COMMITTEE
SET-UP BY
MINISTRY OF ROAD TRANSPORT & HIGHWAYS
(DEPARTMENT OF ROAD TRANSPORT & HIGHWAYS)
GOVERNMENT OF INDIA
27th March 2019

Amendment 4 (04/2019)
To
AIS 153: Additional Requirements for Bus Construction

1.0 Page 6/58, Clause No. 2.11.5

Substitute following text for existing text:

2.11.5 Required escape hatches shall be positioned as follows:

- (a) If there is only one hatch, it shall be situated in the middle third of the passenger compartment; or Note: -In case of buses accommodating CNG/LNG cylinders/Battery/Battery cooling system and AC units on the roof, escape hatch/es shall be positioned suitably.
- (b) If there are two hatches, they shall be separated by a distance of at least 2 m measured between the nearest edges of the apertures in a line parallel to the longitudinal axis of the bus.

2.0 Page 9/58,

Insert new clause 2.18 after the clause 2.17

2.18 Intelligent Transport System (ITS) Equipment

2.18.1 LED Destination Board System for Buses:

2.18.1.1 Fitment of the Destination Boards shall be as per clause 2.2.15 of AIS-052 (Rev.1).

2.18.1.2 LED destination boards, if fitted on Type I buses, shall comply with requirements specified in IS: 16490:2016.

2.18.2 CCTV System with and Integrated Emergency System for Buses:

CCTV System, if fitted, shall be complying with the requirements specified in IS: 16833:2018.

3.0 Page 27/58, Annexure IV, 1(e)

Delete the words and figure namely “Other ITS equipment like PIS signs, SCU, BDC, etc. (if fitted) shall also comply with the tests as specified in Table1 below.”

4.0 Page 28/58, Annexure IV, Sr No 17,18 and 19

Sr No 17,18 and 19 to be deleted.

PRINTED BY
THE AUTOMOTIVE RESEARCH ASSOCIATION OF INDIA
P. B. NO. 832, PUNE 411 004
ON BEHALF OF
AUTOMOTIVE INDUSTRY STANDARDS COMMITTEE
UNDER
CENTRAL MOTOR VEHICLES RULES - TECHNICAL STANDING COMMITTEE
SET-UP BY
MINISTRY OF ROAD TRANSPORT & HIGHWAYS
(DEPARTMENT OF ROAD TRANSPORT & HIGHWAYS)
GOVERNMENT OF INDIA
27th March 2019

Amendment 3 (03/2019)
To
AIS 153: Additional Requirements for Bus Construction

1. Page 7/58, Clause 2.11.7.1.1

Substitute word figure “1,600 mm” for words and figure “minimum 1,600 mm”

2. Page 9/58

Delete Clause Number 2.17

3. Page 13/58, Annexure II, Clause No. 4.2

Add following paragraph at the end of clause

In case, if the length of the test track is shorter than above, then before carrying out test, it should be confirmed that such shorter test track is enough to achieve the required stabilized speed.

4. Page 20/58, Annexure III, Clause No. 11.2.5

Substitute following title for existing title:

11.2.5 In case of any increase in the interior length or a decrease in interior length by less than 10 percent;

5. Page 45/58, Clause No. 3.8.4,

Substitute following title for existing title:

3.8.4: Rearward-facing Wheelchair-Static Test Requirements

PRINTED BY

THE AUTOMOTIVE RESEARCH ASSOCIATION OF INDIA
P. B. NO. 832, PUNE 411 004

ON BEHALF OF
AUTOMOTIVE INDUSTRY STANDARDS COMMITTEE

UNDER
CENTRAL MOTOR VEHICLES RULES - TECHNICAL STANDING COMMITTEE

SET-UP BY
MINISTRY OF ROAD TRANSPORT & HIGHWAYS
(DEPARTMENT OF ROAD TRANSPORT & HIGHWAYS)
GOVERNMENT OF INDIA

27th March 2019

Amd. 2 (02/2019)
To
AIS 153: Additional Requirements for Bus Construction

1. Page 2/60

Add following new clause 1.1.13 after clause number 1.1.12

1.1.13 "Kneeling system" means a system which lowers and lifts totally or partially the body of a vehicle relative to the normal position of travel.

2. Page 3/60, Clause 2.6,

Substitute following text for existing text:

2.6 All buses of Type I, II category shall be fitted with Fire Detection Alarm System (FDAS) and Type III category including Double Deck Buses and Sleeper Coaches shall be fitted with Fire Detection and Suppression System (FDSS) complying with AIS-135:2016, as amended from time to time. However, this requirement shall be optional for buses whose Gross Vehicle Weight (GVW) is less than 3.5 tons.

3. Page 4/60, Clause 2.7,

Substitute following text for existing text:

2.7 Multiplexing/electronic architecture

All buses with 24 V System, shall meet requirements of multiplexing nodes architecture as specified in Annexure IV to this standard.

4. Page 5/60, Clause 2.9.10,

Substitute following text for existing text:

2.9.10 The uniformity of the illuminance over the length of the passenger compartment at a height of 750 mm above all access passages and gangways shall be between 0.15 and 2.

5. Page 26/60, Annexure IV,

Substitute following title for existing title.

ANNEXURE IV
(See clause 2.7)
Multiplexing Nodes Architecture Requirements

6. Page 27/60, Annexure IV, 1 (e)

Substitute following title for existing title.

e Each multiplexing node shall comply with test standards as specified in Table 1 below. Other ITS equipment like PIS signs, SCU, BDC, etc. (if fitted) shall also comply with the tests as specified in Table 1 below.

7. Page 28/60, Annexure IV, Sr. Nos. 9,

Substitute words “Reverse Polarity Protection” for words “Reverse Polarity Protection without fuse”

8. Page 29/60, Annexure IV

Delete Serial Number 12 and renumber subsequent serial numbers:

9. Page 29/60, Annexure IV, Sr. No. 15

Substitute following text for existing text:

15 EMC/EMI As per AIS 004 (Part 3)

10. Page 29/60, Annexure IV, Sr. Nos. 17, 18 and 19

Substitute following text for existing text:

17	LED color test – dominant wave length amber for PIS sign, if fitted	AIS-010 (Part 5)(Rev.1):2010
18	LED chromaticity coordinates for PIS sign, if fitted	AIS-010 (Part 5)(Rev.1):2010
19	LED bulb/SMT intensity and viewing angle for PIS sign, if fitted	In accordance with CIE 127 condition B

11. Page 59/60,

Add new Annexure VII after Annexure VI and renumber subsequent annexures

Annexure VII		
ADDITIONAL TECHNICAL INFORMATION ON BUSES TO BE SUBMITTED BY BUS MANUFACTURER TO TESTING AGENCY		
0.0	Details of Bus manufacturer	
0.1	Name & address of the Bus manufacturer or importer	
0.2	Telephone No.	
0.3	Fax. No.	
0.4	E-mail address	
0.5	Contact person	
0.6	Address of the Plant(s)of manufacture	
0.7	Model Name	
0.8	Variant Name	
0.9	Vehicle Type (As per AIS-052 (Rev.1))	
0.10	Seating Layout Drawing No.	

	0.11	Overall Vehicle Dimensions (mm)	
	0.11.1	Vehicle length, mm	
	0.11.2	Vehicle width, mm	
	0.11.3	Vehicle height, mm	
	0.12	Wheel Base (mm)	
	0.13	Seating Capacity	
	1.0	Technical specification to be given to measure natural frequency	
	1.1	Comfort Class (SDX/NDX/DLX/ACX)	
	1.2	Seat Type	
	1.3	Vehicle Kerb Mass (kg)	
	1.4	Gross Vehicle Mass (kg)	
	1.5	Floor Height from Ground (mm)	
	1.6	CG Location w.r.t. VCS (mm)	
	1.7	No. of Standees	
	1.8	Section Dimensions Details of Super-Structural Members	
	1.9	Material and Mechanical Properties of Super-Structural Members	
	1.10	LH Pillar Numbers	
	1.11	RH Pillar Numbers	
	1.12	Pillar Pitch	
	1.13	AC/NON-AC	
	1.14	Fuel Capacity and Tank Location	
	1.15	Total Mass of Fuel tank with structure	
	1.16	Tyre Size	
	1.16.1	Tyre Ply rating	
	1.16.2	Tyre Pressure in Unladen, PSI	
	1.17	Door Location	
	1.18	Number of service Doors	
	1.19	Total Mass of AC system with structure (If fitted)	
	1.19.1	AC system Location Roof Top FR/RR	
	1.20	Total Mass of Battery assembly system with structure	
	1.21	Battery system Location LH/RH/ FR/RR	
	1.22	Total Mass of Engine/ Motor, Transmission with structure	
	1.23	Engine/ Motor, Transmission Location FR/RR	

	2.0	Technical specification for Noise, Vibration and harshness	
	2.1	Gangway length, mm	
	2.2	Engine / Motor Type	
	2.3	Capacity, cc/ltr	
	2.4	Number of cylinders	
	2.5	Arrangement of cylinders	
	2.6	Type of Fuel (Diesel / Petrol /CNG / LPG / Hybrid / Electric/Ethanol etc.)	
	2.7	Rated Power, Kw	
	2.8	Rated Speed, rpm	
	2.9	Rated Torque, Nm	
	2.10	Type of gear box (MT/AT/CVT)	
	2.11	No. of forward gears	
	2.12	Transmission ratio	
	2.13	Axle ratios & Type	
	2.14	Vehicle Maximum speed, Km/hr	
	2.15	Number of Fan Blades	
	2.16	Fan Type (Mechanical / Viscous / Electric)	
	2.17	Fan Speed, rpm	
	2.18	Fan Design (Fan shroud, Blade Material, thickness, profile & design details)	
	2.19	Noise shield if provided in engine compartment and transmission system a)Material b)Thickness c)Location	
	2.20	Type of Suspension	
	3.0	Fire Detection Alarm System (FDAS)	
	3.1	Name and address of manufacturer of the Fire detectors	
	3.2	Test report number of the FDAS	

	3.3	Description of the device or sketch showing location, relevant dimensions of fire detectors	
	3.4	Devices provided additionally Acoustic or visual If visual, duration and type of optical signal	
	4.0	Fire Detection and Suppression System (FDSS)	
	4.1	Name and address of manufacturer of the fire suppression system	
	4.2	Type of the fire suppression system	
	4.3	Test report number of the FDSS	
	4.4	Extinguishing agent (make and type):	
	4.5	Mass of extinguishing agent:	
	4.6	Type of discharge point(s):	
	4.7	Length of discharge tube	
	4.8	Number of discharge points(s):	
	4.9	Type of propellant gas, if applicable:	
	4.10	Pressure of propellant gas	
	4.11	Minimum operating temperature	
	4.12	Dimensions of pipes and fittings	
	4.13	Detailed description, layout drawings and installation manual of the fire suppression system and its components	
	5.0	Kneeling System (Yes/No)	
	5.1	Floor Height	
	5.2	Kneeling Height	
	5.3	Location of switch for operation of kneeling system for downward, upward and stop position.	
	6.0	Emergency Lighting System (Yes/No)	
	6.1	Location of switch	
	6.2	Min. Time for activation	
	6.3	Location of power supply	
	6.4	Colour of light	
	7.0	Escape Hatches	
	7.1	Number	
	7.2	Aperture Area	

	7.3	Location of Hatches (Roof/Floor)	
	7.4	Distance between hatches (If number of hatches are more than one)	
	7.5	Type of Roof Escape hatch (Ejectable/Hinged/Readily breakable Safety Glass)	
	7.6	If escape hatch is hinged type, angle of hinge	
	8.0	Priority Seats	
	8.1	Forward/Rearward facing	
	8.2	Number	
	8.3	Width of priority seat cushion	
	8.4	Height of uncompressed seat cushion from floor.	
	8.5	Free height above priority seat	
	9.0	Wheelchair	
	9.1	Forward facing/ Rearward facing	
	9.2	Wheelchair accommodation provisions	
	9.2.1	Width	
	9.2.2	length	
	9.3	Percentage of Slope	
	9.4	Height of wheelchair access door	
	9.5	Width of wheelchair access door	
	9.6	Foldable or detachable seats in wheelchair area provided (Yes/ No)	
	9.7	Type of wheelchair restraint system	
	10.0	Pram or push chair	
	10.1	Accommodation provisions	
	10.1.1	Width	
	10.1.2	length	
	11.0	Boarding Devices	
	11.1	Type Lift/Ramp	
	11.2	Area of boarding	
	11.2.1	Length	
	11.2.2	Width	
	11.3	Load Carrying capacity of boarding device	
	11.4	Slope of ramp in %	

	11.5	Slope of extended ramp if provided in %	
	11.6	Mode of operation of ramp (Manual/ power operated)	
	12.0	Multiplexer (Give Details for each Node)	
	12.1	Make	
	12.2	Model	
	12.3	Hardware Version	
	12.4	Software Version	
	12.5	Part No	
	13.0	Public Information System (Give Details for Front/Rear/Side/Internal Display)	
	13.1	Make	
	13.2	Model	
	13.3	Hardware Version	
	13.4	Software Version	
	13.5	Part No	
	14.0	Singe Controller Unit (SCU) - If Fitted	
	14.1	Make	
	14.2	Model	
	14.3	Hardware Version	
	14.4	Software Version	
	14.5	Part No	
	15.0	Bus Driver Console (BDC)- If Fitted	
	15.1	Make	
	15.2	Model	
	15.3	Hardware Version	
	15.4	Software Version	
	15.5	Part No	
	16.0	Security Camera Network- If Fitted	
	16.1	Make	
	16.2	Model	
	16.3	Hardware Version	
	16.4	Software Version	
	16.5	Part No	
	17.0	Announcement System (Mic/Amplifier) If Fitted	
	17.1	Make	

17.2	Model	
17.3	Hardware Version	
17.4	Software Version	
17.5	Part No	

PRINTED BY

THE AUTOMOTIVE RESEARCH ASSOCIATION OF INDIA
P. B. NO. 832, PUNE 411 004
ON BEHALF OF

AUTOMOTIVE INDUSTRY STANDARDS COMMITTEE
UNDER

CENTRAL MOTOR VEHICLES RULES - TECHNICAL STANDING COMMITTEE
SET-UP BY

MINISTRY OF ROAD TRANSPORT & HIGHWAYS
(DEPARTMENT OF ROAD TRANSPORT & HIGHWAYS)
GOVERNMENT OF INDIA

14th February 2019

Amd. 1 (09/2018)

To

AIS-153: Additional Requirements for Bus Construction.

1. Page 3/58, Table in clause No 2.3.2.1.1, first row third column

Substitute following text for existing text:

Front mechanical and rear air suspension

2. Page 3/58, Table in clause No 2.3.2.1.1, first row fourth column

Substitute figure “1.5” for figure “1”.

3. Page 3/58, Clause No 2.4.1.2

Substitute following text for existing text:

2.4.1.2 When tested as specified in 5.4 of Annexure III, the dominant frequencies falling in the range of 0.5-1 Hz, 5-7 Hz and 18-20 Hz shall not exceed 3 m/s² for driver seat & 10 m/s² for passenger seats.

4. Page 3/58, Clause No 2.6

Substitute following text for existing text:

All buses of Type I, II category shall be fitted with Fire Detection Alarm System (FDAS) and Type III category including Double Deck Buses and Sleeper Coaches shall be fitted with Fire Detection and Suppression System (FDSS) complying with AIS-135:2016, as amended from time to time. However, this requirement shall be optional for buses whose Gross Vehicle Weight (GVW) is less than 3.5 tons.

All school buses shall be fitted with Fire Detection and Suppression System (FDSS) complying with AIS-135:2016, as amended from time to time.

5. Page 5/58, Clause No 2.10

Substitute following text for existing text:

2.10 Forms of visual entertainment for passengers if fitted, for example television monitors or videos, shall be located out of the driver's view when the driver is seated in his normal driving position. This shall not preclude any television monitor or similar device used as part of the driver's control or guidance of the bus, for example to monitor service doors.

6. Page 6/58, Clause No 2.11.6.4

Substitute following text for existing text:

2.11.6.4 Hinged escape hatches shall hinge along the edge towards the front or rear or side of the bus and shall hinge through an angle of at least 100 degree. Hinged floor escape hatches shall hinge into the passenger compartment.

7. Page 7/58, Clause No 2.11.7.2.1

Substitute following text for existing text:

2.11.7.2. In the case of an escape hatch fitted in the floor, the hatch shall give direct and free access to the exterior of the bus with openable of skirt panel and be fitted where there is a clear space above the hatch equivalent to the height of the gangway. Any heat source or moving components shall be at least 500 mm from any part of the hatch aperture.

8. Page 9/58, Clause No 2.16

Delete clause 2.16 and renumber subsequent clause.

9. Page 13/58, Annexure II, Clause No 5.3.1

Substitute following text for existing text:

5.3.1 Openings such as skylights, all windows and ventilating inlets and/or outlets shall be shut if possible, Wherever the shutting is not possible, it shall be mentioned in report clearly

10. Page 14/58, Annexure II, Clause No 5.4.1.2

Substitute following text for existing text:

5.4.1.2 Gear position of transmission

A single highest possible gear (including that of auxiliary transmission) that allows the stable running of the test vehicle shall be used. If the test vehicle is capable of selecting 4-wheel drive or 2-wheel drive the vehicle shall be run with the 2-wheel drive.

Vibration levels are to be determined at least three speeds to cover the range specified above.

11. Page 16/58, Annexure II, Clause No 6.2

Substitute following text for existing text:

- 6.2 For a vehicle with three or more than three rows of seats the interior vibration shall be measured with the accelerometer position at the following three positions. Driver's seat as the first position, second position at the middle row (in case of odd number of rows considering driver seat as the 1st row) and front seat out of the 2 middle seats (in case of even number of rows considering driver seat as the 1st row) of the multiple seat rows and third position at the last row of seats for the seat positions nearest to the longitudinal axis of the vehicle.

12. Page 19/58, Annexure II, Clause No 11.1 and 11.2

Substitute following text for existing text:

- 11.1 This clause gives the factors to be considered while selecting a vehicle to represent a range of variants for establishing compliance of a model for type approval to meet the test requirements of 8 for test conducted as per 5.4

This also applies to,

- a) Extension of type approval for changes in technical specifications of an already type approved model; and
- b) Establishing compliance of new model/ variant(s) based on already type approved model.

- 11.2 In case of following changes, the verification shall be carried out for establishing compliance of the changed parameters to the requirements specified in this standard. The following is applicable only for the verification as per 5.4:

- 11.2.1 In case of change in engine type, capacity, number and arrangement of cylinders, test needs to be conducted for compliance.

- 11.2.1.1 In case of change in base diesel engine to Petrol, CNG or LPG or base petrol engine to CNG or LPG keeping the power within the tolerance specified below, no test needs to be conducted for compliance:

- 11.2.2 In case of increase in rated engine power upto 10 percent or any decrease of rated engine power, no test needs to be conducted for compliance;

- 11.2.3 In case of increase in rated engine speed upto 10 percent or any decrease of rated engine speed, no test needs to be conducted for compliance;

- 11.2.4 In case of any changes in transmission ratios, axle ratios and type, size and ply rating of tyres, no test needs to be conducted for compliance;

- 11.2.5 In case of any increase in the interior length or a decrease in interior length by less than 10 percent, no test needs to be conducted for compliance;

- 11.2.6 In case of any decrease in the maximum fan tip speed or an increase in the fan tip speed up to 10 percent, no test needs to be conducted for compliance;
- 11.2.7 In case of any decrease in the blades or an increase in the number of blades up to 30 percent (rounded off to nearest whole number, as per Indian Standard), no test needs to be conducted for compliance;
- 11.2.8 In case of change in the fan drive from mechanical to either viscous or electrical or from viscous to electrical, no test needs to be conducted for compliance;
- 11.2.8.1 In case of any change in fan shroud, blade material, thickness, profile and design details, no test needs to be conducted for compliance;
- 11.3 Changes other than the above are considered as not affecting compliance and do not call for any test.

13. Page 22/58, Annexure III, Clause No 5.3.1

Substitute following text for existing text:

- 5.3.1 Openings such as skylights, all windows and ventilating inlets and/or outlets shall be shut if possible, Wherever the shutting Is not possible, it shall be mentioned in report clearly

14. Page 22/58, Annexure III, Clause No 5.4

Substitute following text for existing text:

5.4 Vehicle Operating Conditions

Vibration level at driver and passenger seat locations shall be measured while the vehicle is accelerated from minimum possible speed to maximum possible speed or 80 kmph whichever is lower, in single highest gear and decelerated to minimum speed in the same gear. A single highest possible gear (including that of auxiliary transmission) that allows the stable running of the test vehicle shall be used. If the test vehicle has a drive train selectable between 4-wheel drive or 2-wheel drive the vehicle shall be run with the 2-wheel drive.

15. Page 23/58, Annexure III, Clause No 6.2

Substitute following text for existing text:

- 6.2 For a vehicle with three or more than three rows of seats the interior vibration shall be measured with the accelerometer position at the following three positions. Driver's seat as the first position, second position at the middle row (in case of odd number of rows considering diver seat as the 1st row) and front seat out of the 2 middle seats (in case of even number of rows considering diver seat as the 1st row) of the multiple seat rows and third position at the last

row of seats for the seat positions nearest to the longitudinal axis of the vehicle.

16. Page 23/58, Annexure III, Clause No 7.0

Substitute following text for existing text:

7.0 Vibration level at driver and passenger seat locations shall be measured while the vehicle is accelerated from minimum possible speed to maximum possible speed or 80 kmph whichever is lower, in single highest gear and decelerated to minimum speed in the same gear. At least two measurements shall be made at each accelerometer position. If the spread of results of the vibration levels obtained under any measuring condition exceeds 20% deviations, further measurements shall be made until the readings of two independent successive measurements fall within a range of 20%; the mean value of these two readings shall be recorded as the test result. The values stated in the test report shall be rounded to the nearest integral decibel.

Any peak which is obviously out of character with the general vibration level being read should be ignored.

17. Page 25/58, Annexure III, Clause No 11.1 and 11.2

Substitute following text for existing text:

11.1 This clause gives the factors to be considered while selecting a vehicle to represent a range of variants for establishing compliance of a model for type approval to meet the test requirements of 2.4 for test conducted as per 5.4

This also applies to,

- a) Extension of type approval for changes in technical specifications of an already type approved model; and
- b) Establishing compliance of new model/ variant(s) based on already type approved model.

11.2 In case of following changes, the verification shall be carried out for establishing compliance of the changed parameters to the requirements specified in this standard. The following is applicable only for the verification as per 5.4.:

11.2.1 In case of change in engine type, capacity, number and arrangement of cylinders, test needs to be conducted for compliance.

- 11.2.1.1 In case of change in base diesel engine to Petrol, CNG or LPG or base petrol engine to CNG or LPG keeping the power within the tolerance specified below, no test needs to be conducted for compliance;
- 11.2.2 In case of increase in rated engine power upto 10 percent or any decrease of rated engine power, no test needs to be conducted for compliance;
- 11.2.3 In case of increase in rated engine speed upto 10 percent or any decrease of rated engine speed, no test needs to be conducted for compliance;
- 11.2.4 In case of any changes in transmission ratios, axle ratios and type, size and ply rating of tyres, no test needs to be conducted for compliance;
- 11.2.5 In case of any increase in the interior length or a decrease in interior length by less than 20 percent, no test needs to be conducted for compliance;
- 11.2.6 In case of any decrease in the maximum fan tip speed or an increase in the fan tip speed up to 10 percent, no test needs to be conducted for compliance;
- 11.2.7 In case of any decrease in the blades or an increase in the number of blades up to 30 percent (rounded off to nearest whole number, as per Indian Standard), no test needs to be conducted for compliance;
- 11.2.8 In case of change in the fan drive from mechanical to either viscous or electrical or from viscous to electrical, no test needs to be conducted for compliance;
- 11.2.8.1 In case of any change in blade material, thickness, profile and design details, blade material, thickness, profile and design details, no test needs to be conducted for compliance; For fan shroud minor changes like local profile/depression (required for packaging) are allowed, except in the fan area ;
- 11.3 Changes other than the above are considered as not affecting compliance and do not call for any test.

18. Page 27/58, Annexure IV, Clause No 1.0

Substitute following text for existing text:

1.0 Architecture-'Node'

19. Page 27/58, Annexure IV, Clause No 1.0 (c) (iii)

Substitute following text for existing text:

iii Digital high / low side

20. Page 27/58, Annexure IV, Clause No 1.0 (e)

Substitute following text for existing text:

(e) Each node to be minimum IP54 certified and to comply with test standards as specified in Table 1 below

21. Page 28/58, Annexure IV, Table 1, Clause No 6.0

Substitute following text for existing text:

Dust and Water Ingress protection

IS /IEC 60947-1:2004 in conjunction with IS/IEC 60529:2001, 'nodes' IP54

22. Page 30/58, Annexure V, Clause No. 3.2.2

Substitute following text for existing text:

3.2.2 There may be adequate space for a guide dog under, or adjacent to, at least one of the priority seats. This space shall not form a part of the gangway.

23. Page 40/58, Annexure V, Clause No. 3.7.3

Substitute following text for existing text:

3.7.3 For buses, where the foot space of any seat, or part of a folding seat when in use, intrudes into a wheelchair space, those seats shall have signs fixed on or adjacent to them with the following text, equivalent text or pictogram:

"Please give up this space for a wheelchair user".

The provisions of Paragraph 3.7.4.1 of this Annexure shall apply to any textual markings used.

24. Page 48/58, Annexure V, Clause No. 3.10

Substitute following text for existing text:

Provisions for the Accommodation of Unfolded Prams and Pushchairs, if provided

25. Page 52/58, Annexure V, Clause No. 3.11.4.1.3

Substitute following text for existing text:

3.11.4.1.3 The useable surface of a ramp shall be at least 800mm wide. The slope of the ramp, when extended or folded out on to a kerb of 150

mm in height, should not exceed 25%. The slope of the ramp, when extended or folded out to the ground, should not exceed 60%. A kneeling system may be used to achieve this test.

PRINTED BY

THE AUTOMOTIVE RESEARCH ASSOCIATION OF INDIA
P. B. NO. 832, PUNE 411 004
ON BEHALF OF

AUTOMOTIVE INDUSTRY STANDARDS COMMITTEE
UNDER

CENTRAL MOTOR VEHICLES RULES - TECHNICAL STANDING COMMITTEE
SET-UP BY

MINISTRY OF ROAD TRANSPORT & HIGHWAYS
(DEPARTMENT OF ROAD TRANSPORT & HIGHWAYS)
GOVERNMENT OF INDIA

8th September 2018

AUTOMOTIVE INDUSTRY STANDARD

**Additional Requirements for
Bus Construction**

PRINTED BY
THE AUTOMOTIVE RESEARCH ASSOCIATION OF INDIA
P.B. NO. 832, PUNE 411 004

ON BEHALF OF
AUTOMOTIVE INDUSTRY STANDARDS COMMITTEE

UNDER
CENTRAL MOTOR VEHICLE RULES – TECHNICAL STANDING COMMITTEE

SET-UP BY
MINISTRY OF ROAD TRANSPORT & HIGHWAYS
(DEPARTMENT OF ROAD TRANSPORT & HIGHWAYS)
GOVERNMENT OF INDIA

May 2018

Status chart of the standard to be used by the purchaser for updating the record

Sr. No.	Corrigenda	Amend-ment	Revision	Date	Remark	Misc.

INTRODUCTION

The Government of India felt the need for a permanent agency to expedite the publication of standards and development of test facilities in parallel when the work on the preparation of the standards is going on, as the development of improved safety critical parts can be undertaken only after the publication of the standard and commissioning of test facilities. To this end, the erstwhile Ministry of Surface Transport (MOST) has constituted a permanent Automotive Industry Standards Committee (AISC) vide order No.RT-11028/11/97-MVL dated September 15, 1997. The standards prepared by AISC will be approved by the permanent CMVR Technical Standing Committee (CTSC). After approval, the Automotive Research Association of India, (ARAI), Pune, being the Secretariat of the AIS Committee, has published this standard. For better dissemination of this information ARAI may publish this document on their web site.

Based on the discussions in 50th and 51st meeting of CMVR TSC, this standard has been formulated covering Additional Requirements for Bus Construction viz., requirements for Fire Suppression System, requirements for accommodation and accessibility for passengers of reduced mobility, access to emergency door/window, Escape hatches and mandatory requirement for escape hatches, requirements for noise, vibration and harshness etc.

The AISC panel and the Automotive Industry Standards Committee (AISC) responsible for preparation of this standard are given in Annex-VII and Annex-VIII respectively.

Additional Requirements for Bus Construction

Clause/ Annex No.	Contents	Page No.
1.0	Scope	1/58
2.0	Technical and safety requirements	2/58
Annexure I	Computer Simulation of Vibration Test to find out Lowest Natural Frequency of M2 & M3 Bus Category	10/58
Annexure II	Automotive Vehicles — Interior Vibration — Method of Measurement and Requirements	12/58
Annexure III	Automotive Vehicles — Interior Harshness — Method of Measurement and Requirements	21/58
Annexure IV	Multiplexing/Electronic Architecture Requirements	27/58
Annexure V	Accommodation and Accessibility For Passengers With Reduced Mobility	30/58
Annexure VI	The Reactive Forces Of Power-Operated Ramps	54/58
Annexure VII	AISC Panel Composition	57/58
Annexure VIII	Automotive Industry Standards Committee Composition	58/58

AIS-153: Additional Requirements for Bus Construction.**1.0 SCOPE**

The provisions of this code are applicable to buses covered under scope of AIS-052(Rev.1).

1.1 Definitions - For the purpose of this code

- 1.1.1 The definitions given in AIS-052(Rev.1) and its amendments in force at the time of application for type approval shall apply to this standard.
- 1.1.2 "**Low floor bus**" is a bus of Type I, II in which at least 35% of the area available for standing passengers (or in its forward section in the case of articulated buses, or in its lower deck in the case of double-decker buses) forms an area without steps and includes access to at least one service door.
- 1.1.3 "**Emergency lighting system**" means a system that provides a minimum level of lighting necessary to enable occupants to safely egress from the bus, including the emergency exits.
- 1.1.5 "**Passenger with reduced mobility**" means all passengers who have a difficulty when using public transport, such as disabled people (including people with sensory and intellectual impairments, and wheelchair users, people with limb impairments, people of small stature, people with heavy luggage, elderly people, pregnant women, people with shopping trolleys, and people with children (including children seated in pushchairs).
- 1.1.6 "**Wheelchair user**" means a person who due to infirmity or disability uses a wheelchair for mobility.
- 1.1.7 "**Priority seat**" means a seat with additional space for a passenger with reduced mobility and marked accordingly.
- 1.1.8 "**Boarding device**" means a device to facilitate wheelchair access to buses, such as lifts, ramps, etc.
- 1.1.9 "**Lift**" means a device or system with a platform that can be raised and lowered to provide passenger access between the floor of a passenger compartment and the ground or kerb.
- 1.1.10 "**Ramp**" means a device to bridge the gap between the floor of a passenger compartment and the ground or kerb. In its position for use, it includes any surface that may move as part of the ramp deployment or be available for use only when the ramp is in its deployed position and over which a wheelchair is intended to travel.

1.1.11 **"Portable ramp"** means a ramp that may be detached from the bus structure and capable of being deployed by a driver or crew member.

1.1.12 **"Demountable seat"** means a seat that can be easily detached from the bus.

2.0 **Technical and safety requirements**

2.1 **Engine Power to Gross Vehicle Weight**

All buses shall have power to gross vehicle weight ratio greater than 5 kW/ton.

2.2 **Acceleration**

All buses shall achieve acceleration greater than 0.5 m/s^2 to achieve speed from 0 to 30 kmph within 14s when tested as per procedure laid down in IS:11851-1986 (Reaffirmed 2017), as amended from time to time.

2.3 **Interior noise level requirements**

Interior noise level of buses with front engine shall not exceed 85 dB (A) and that for buses with rear engine shall not exceed 80 dB (A), when tested as per IS: 12832-2010 (Reaffirmed 2016), as amended from time to time.

2.3 **Vibration:**

2.3.1 **Lowest natural frequency**

2.3.1.1 **Requirements**

Bus structure shall have adequate stiffness to ensure that the lowest natural frequency of the vehicle sprung mass (i.e chassis and body) shall be greater than equal to 5 Hz for modes like vertical force, bending and greater than equal to 3 Hz in case of torsional mode under following static loading condition:

Normal Loads = Number of Passenger x [weight of the passenger (68 kg) + Passenger luggage weight (7kg)]

Explanation: 1st global mode representing lowest natural frequency of the vehicle structure which includes chassis and superstructure together shall be greater than equal to 5Hz for vertical force and bending modes and greater than equal to 3 Hz in case of torsional mode. Panel and other local part modes shall be ignored while predicting lowest natural frequency of the vehicle.

2.3.1.2 Evaluation procedure is given in Annexure I.

2.3.2 Acceleration Levels

2.3.2.1 Requirements

- 2.3.2.1.1 When tested as specified in 5.4.1 of Annexure II, the maximum (rms) vibrations level acceleration a_v value as per Clause No. 6.5 of ISO 2631 Part 1:1997 shall not exceed the following limits*.

	Front and rear mechanical suspension	Front air and rear mechanical suspension	Front and rear air suspension
At driver and passenger seats	3 m/s ²	2 m/s ²	1 m/s ²
At gangway	6 m/s ²	4 m/s ²	2 m/s ²

- 2.3.2.2 Testing procedure is given in Annexure II.

2.4 Harshness (Transient Vibration) :

2.4.1 Requirements

- 2.4.1.1 When tested as specified in 5.4 of Annexure III, the maximum transient (running rms) vibrations level a_v value as per Clause No. 6.5 of ISO 2631 Part 1: 1997 shall not exceed 0.3g [3 m/s²] at driver seat and 1g[10 m/s²] at passenger seats.

- 2.4.1.2 When tested as specified in 5.4 of Annexure III, the dominant frequencies to fall outside the range of 0.5-1 Hz, 5-7 Hz and 18-20 Hz.

- 2.4.1.3 Testing procedure is given in Annexure III.

2.5 Braking Performance & Vehicle Stability Function

All buses shall comply for improved braking performance and Vehicle Stability Function in accordance with AIS-150:2018, as amended from time to time.

2.6 Fire Detection and Alarm System/, Fire Detection and Suppression system

All buses of Type I, II category including School bus shall be fitted with Fire Detection Alarm System (FDAS) and Type III category including Double Deck Buses and Sleeper Coaches shall be fitted with Fire Detection and Suppression System (FDSS) complying with AIS-135:2016, as amended from time to time. However, this requirement shall be optional for buses whose Gross Vehicle Weight (GVW) is less than 3.5 tons except for school buses.

2.7 **Multiplexing/electronic architecture**

All buses with 24 V System, shall meet requirements of multiplexing and electronic architecture as specified in Annexure IV to this standard.

2.8 **Kneeling System**

All Low floor buses with 400 mm floor height and with Air suspension shall meet requirements of kneeling system. Kneeling height shall be 60 mm at the entry/exit level.

Buses with 401-650 mm floor height may be provided with ramp.

2.8.1 Unless otherwise stated, all measurements shall be made when the bus is at its unladen weight and it is standing on a smooth and horizontal ground surface and in the normal condition for travel. If a kneeling system is fitted, it shall be set so the buses at its normal ride height for travel. In the case of approval of bodywork as a separate technical unit, the position of the body relative to the flat horizontal surface shall be specified by the manufacturer.

2.8.2 Wherever there is a requirement in this Standard for a surface in the bus to be horizontal or at a specific angle when the bus is at its unladen weight, in the case of a bus with mechanical suspension, the surface may exceed this slope or possess a slope when the bus is in unladen weight, provided that this requirement is met when the bus is in the loading condition declared by the manufacturer. If a kneeling system is fitted to the bus, it shall not be in operation.

2.8.3 In low floor buses only a kneeling system, but not a retractable step, may be engaged. In other buses either a kneeling system and/or a retractable step may be engaged.

2.8.4 In the event of the failure of a safety device, lifts, ramps and kneeling systems shall be incapable of operation, unless they can be safely operated by manual effort. The type and location of the emergency operating mechanism shall be clearly marked. In the event of power failure, lifts and ramps shall be capable of manual operation.

2.8.5 A switch shall be required to enable operation of the kneeling system.

2.8.6 Any control which initiates the lowering or raising of any part or the whole of the bodywork relative to the road surface shall be clearly identified and be under the direct control of the driver.

2.8.7 The lowering process shall be capable of being stopped and immediately reversed by a control both within the reach of the driver, whilst seated in the cab, and also adjacent to any other operating controls provided for the operation of the kneeling system.

2.8.8 Any kneeling system that is fitted to a bus shall not allow the bus to be driven at a speed of more than 5km/h when the bus is lower than the normal height of travel.

2.9 **Emergency Lighting System**

- 2.9.1 Buses of Type II, III shall be equipped with an emergency lighting system.
- 2.9.2 It shall be possible for the driver to activate the emergency lighting system from the driver's seating position.
- 2.9.3 The operation of the emergency control of any service or emergency door shall activate the emergency lighting system.
- 2.9.4 The emergency lighting system, once activated, shall remain active for at least 30 minutes unless de-activated by the driver.
- 2.9.5 The power supply for the emergency lighting shall be suitably located within the bus to minimise the risk of its continued operation being prejudiced as the result of an accident.
- 2.9.6 All units providing the emergency lighting shall produce a white light.
- 2.9.7 Maximum uniformity of illuminance = $\frac{\text{Maximum lighting level recorded}}{\text{Average lighting level recorded}}$
- 2.9.8 Minimum uniformity of illuminance = $\frac{\text{Minimum lighting level recorded}}{\text{Average lighting level recorded}}$
- 2.9.9 The emergency lighting system shall provide a minimum illuminance of 10lx throughout the passenger compartment at a height of 750mm above gangway floor.
- 2.9.10 Highest illumination shall not be more than twice the least illuminance
- 2.9.11 The emergency lighting system shall provide a minimum illuminance of 1lx at floor level in the centreline of all access passages and gangways and at the centre of any step, at step level.
- 2.9.12 Conformity with the uniformity requirements shall be demonstrated over a period of at least 30min from initiation of the emergency lighting by measurements taken at distances not exceeding 2m.
- 2.9.13 Control of the mandatory interior lighting shall be by manual switches under the control of the driver or automatically controlled.
- 2.9.14 Individual lights for each of the items in Paragraph 2.9.1 above are not required providing adequate illumination can be maintained during normal use.

2.10 **Visual Entertainment:**

Forms of visual entertainment for passengers, for example television monitors or videos, shall be located out of the driver's view when the driver is seated in his normal driving position. This shall not preclude any television monitor or similar device used as part of the driver's control or guidance of the bus, for example to monitor service doors.

2.11 **Escape Hatches:**

2.11.1 Buses of Type II, III shall be fitted with escape hatches, additional to the emergency doors and windows. The requirement for escape hatches shall be optional for buses whose Gross Vehicle Weight (GVW) is less than 3.5 tons. The minimum number of hatches shall be:

Number of passengers	Number of hatches
Not exceeding 30	1
Exceeding 30	2

2.11.2 Escape hatches shall have an aperture with a minimum area as specified in clause number 2.2.4.16.2 of AIS-052(Rev.1)

2.11.3 Except as provided in Paragraph 2.11.4 hatches may also be fitted in the case of Type I buses.

2.11.4 Hatches shall not be fitted where technical components are installed which present possible dangers to passengers using the escape hatches (e.g. high voltage systems, systems containing dangerous liquids and/or gas, etc.).

2.11.5 **Required escape hatches shall be positioned as follows:**

- (a) If there is only one hatch, it shall be situated in the middle third of the passenger compartment; or
- (b) If there are two hatches, they shall be separated by a distance of at least 2 m measured between the nearest edges of the apertures in a line parallel to the longitudinal axis of the bus.

2.11.6 **Technical Requirements for Escape Hatches**

2.11.6.1 Every escape hatch shall operate so as not to obstruct the clear passage from inside or outside the bus.

2.11.6.2 Roof escape hatches shall be ejectable, hinged or made of readily-breakable safety glass. Floor hatches shall be either hinged or ejectable and shall be fitted with an audible warning device to warn the driver when it is not securely closed. The floor escape hatch lock, and not the movement of the hatch itself, shall actuate this device. Floor escape hatches shall be proofed against unintentional operation. However this requirement shall not apply if the floor hatch is locked automatically when the bus is moving at a speed exceeding 5 km/h.

2.11.6.3 Ejectable types shall not become totally detached from the bus when operated such that the hatch is not a danger to other road users. The operation of ejectable escape hatches shall be such that inadvertent operation is effectively prevented. Floor ejectable hatches shall eject only into the passenger compartment.

2.11.6.4 Hinged escape hatches shall hinge along the edge towards the front or rear of the bus and shall hinge through an angle of at least 100 degree. Hinged floor escape hatches shall hinge into the passenger compartment.

2.11.6.5 Escape hatches shall be capable of being easily opened or removed from the inside and from the outside. However, this requirement shall not be construed as precluding the possibility of locking the escape hatch for the

purpose of securing the bus when unattended, provided that the escape hatch can always be opened or removed from the inside by the use of the normal opening or removal mechanism. In the case of a readily-breakable hatch, a device shall be provided adjacent to the hatch, readily available to persons inside the bus, to ensure that the hatch can be broken.

2.11.7 **Access to Escape Hatches**

2.11.7.1 **Escape Hatches in the Roof**

2.11.7.1.1 Except in the case of Type I buses, at least one escape hatch shall be located such that a four-sided truncated pyramid having a side angle of 20 degree and a height of minimum 1,600 mm touches part of a seat or equivalent support. The axis of the pyramid shall be vertical and its smaller section shall contact the aperture area of the escape hatch. Supports may be foldable or moveable provided they can be locked in their position of use. This position shall be taken for verification.

2.11.7.1.2 When the structural thickness of the roof is more than 150 mm, the smaller section of the pyramid shall contact the aperture area of the escape hatch at the level of the outside surface of the roof.

2.11.7.2 **Escape Hatches in the Floor**

2.11.7.2.1 In the case of an escape hatch fitted in the floor, the hatch shall give direct and free access to the exterior of the bus and be fitted where there is a clear space above the hatch equivalent to the height of the gangway. Any heat source or moving components shall be at least 500 mm from any part of the hatch aperture.

2.11.7.2.2 It shall be possible to move a test gauge in the form of a thin plate having dimensions 600 mm X 400 mm with corners radi used by 200 mm in a horizontal position from a height above the floor of the bus of 1m to the ground.

2.12 **Accommodation and Accessibility for Passengers of Reduced Mobility**

Vehicles of Type I with maximum 650 mm floor height shall be accessible for people with reduced mobility including at least one wheel chair user according to the technical provisions laid down in Annexure V. However, if vehicles of Type II, Type III and Type IV are voluntarily equipped with features or devices for persons with reduced mobility and / or wheel chair user, those features or devices shall comply with the relevant requirements of Annexure V. However, wheelchair accommodation provisions shall not be applicable for buses whose Gross Vehicle Weight (GVW) is less than 3.5 tons.

2.13 **Access to Emergency Doors (See Fig. 1)**

The following requirements shall not apply to

- Driver's doors used as emergency exits in buses having a capacity not exceeding 22 passengers.
- Buses whose Gross Vehicle Weight (GVW) is less than 3.5 tons.

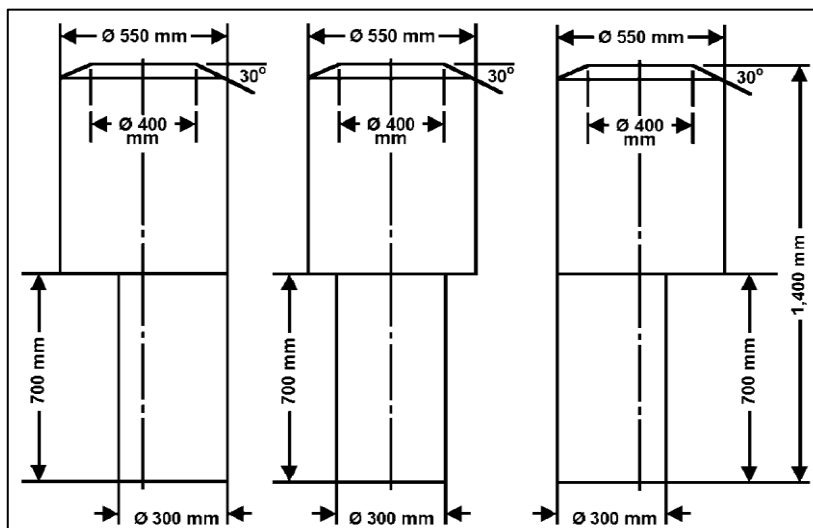

Figure 1

Access to Emergency Doors

- 2.13.1 Except as provided for in Paragraph 2.13.1.4 below, the free space between the gangway and the emergency door aperture shall permit the free passage of a vertical cylinder 300 mm in diameter and 700 mm high from the floor and supporting a second vertical cylinder 550 mm in diameter, the aggregate height of the assembly being 1,400 mm.

The diameter of the upper cylinder may be reduced at the top to 400 mm when a chamfer not exceeding 30° from the horizontal is included.

- 2.13.1.1 Except as provided for in Paragraph 2.13.1.4 below, the free space between the gangway and the emergency door aperture shall permit the free passage of a vertical cylinder 300 mm in diameter and 700 mm high from the floor and supporting a second vertical cylinder 550 mm in diameter, the aggregate height of the assembly being 1,400 mm.

The diameter of the upper cylinder may be reduced at the top to 400 mm when a chamfer not exceeding 30° from the horizontal is included.

- 2.13.1.2 The base of the first cylinder shall be within the projection of the second cylinder.

- 2.13.1.3 Where folding seats are installed alongside this passage, the free space for the cylinder shall be required to be determined when the seat is in the position for use.

- 2.13.1.4 As an alternative to the dual cylinder, the gauging device described in Paragraph 2.2.8.1 of AIS-052 (Rev.1) may be used

2.14 Prevention of Accidents:

If the engine compartment of a bus is located to the rear of the driver's compartment, it shall not be possible to start the engine from the driver's position when the main engine access panel located in the rear face of the bus is open and which provide direct access to parts that represent a hazard

when the engine is running (e.g. pulley of belt drives).

2.15 **Trap Door, if fitted**

Every trap door, that is not an escape hatch, on the floor of a bus shall be so fitted and secured that it cannot be dislodged or opened without the use of tools or keys. Projection of all mounting screws for trap door other than gear box cover shall not exceed 8 mm.

2.16 **Design Type Approval**

All bus body structures and structural aggregates may be designed to fulfill the loading, operating and performance parameters using physical test, finite element analysis or any other calculation method.

2.17 **Additional seat requirements**

In addition to Clause No. 2.2.11 of AIS 052 (Rev.1) on Seats requirements, all seats shall also comply with Clause nos. 3.2.7.1 to 3.2.7.7 of Annexure V of this standard.

ANNEXURE I

(See 2.3.1.2)

**COMPUTER SIMULATION OF VIBRATION TEST TO FIND OUT
LOWEST NATURAL FREQUENCY OF M2 & M3 BUS CATEGORY****1.0 ADDITIONAL DATA AND INFORMATION**

The structure of M2 & M3 bus category need to meet the requirements specified in Paragraphs 2.3.1 of this standard by a computer simulation method approved by the testing agency. The following information shall be supplied to the testing agency:

- 1.1 3D CAD model of entire bus structure (chassis and superstructure) including drawings
- 1.2 Vehicle and aggregate mass details (Kerb and Laden weight)
- 1.3 Material properties of chassis and superstructure assemblies
- 1.4 Physically measured centre of gravity
- 1.5 Seat layout and standee floor clearly marked on the drawings

2.0 THE MATHEMATICAL MODEL

The model shall be built in such a way that it shall be capable of describing the real physical behaviour of the vehicle. The mathematical model shall be constructed, and assumptions prescribed, in such a way that the calculation gives conservative results. The model shall be built up with the following considerations:

- 2.1. The total mass and the centre of gravity position used in the mathematical model shall be identical to those of the vehicle to be approved.
- 2.2. The mass distribution in the mathematical model shall correspond to the vehicle to be approved.
- 2.3. The model should capture details of vehicle sprung mass only i.e. Vehicle Super structure and chassis without suspension.

3.0 REQUIREMENTS FOR SIMULATION AND COMPUTING

- 3.1. The vehicle model shall be in free-free condition i.e. without any boundary conditions
- 3.2. The vehicle shall be in laden condition with passenger weight of 75 kg which includes 68 kg of passenger weight and 7 kg of passenger luggage weight.
- 3.3 The passenger weight shall be added at seat location and standee location
- 3.4 Seat mass shall be lumped at 'H' point of the seat
- 3.5 Standee mass is to be lumped at 875mm from floor in vertical direction as per standee layout marked in the drawing

3.6 Natural frequency determination is to be performed using Finite Element Analysis (FEA) code. A description of the applied simulation and calculation method which has been utilised, and clear precise identification of the analysis software, including at least its commercial name and the version used shall be specified.

4.0 EVALUATION OF THE SIMULATION

4.1 First global mode of the vehicle structure need to be checked.

4.2 The modal displacements for superstructure and chassis to be seen together.

4.3. No panel or other part modes to be seen.

5.0 DOCUMENTATION

5.1. The report on the simulation shall contain the following information:

5.1.1. All the data and information stated in Paragraph 1.0 of this Annexure,

5.1.2. A drawing showing the mathematical model of the vehicle,

5.1.3. A statement of the values of kerb weight, Gross vehicle weight, vehicle CG, Number of seating and standee passenger

5.1.4. Material properties used for the vehicle

5.1.6. Plots or data which show in an appropriate way that the requirements specified in Paragraphs 2.3.1. of this standard are met. This requirement can be satisfied by the provision of a global displacement plot for superstructure and chassis together for first global mode.

5.1.7. A statement of whether, or not, the requirements specified in Paragraphs 2.3.1 of this standard have been met,

5.1.8. All the data and information necessary for the clear identification of the vehicle type, its superstructure, the mathematical model of the superstructure, and the calculation itself.

5.2. At the request of the testing agency, further information shall be provided and included in the report.

ANNEXURE II

(See 2.3.2.2)

AUTOMOTIVE VEHICLES — INTERIOR VIBRATION — METHOD OF MEASUREMENT AND REQUIREMENTS

1.0 REFERENCES

The following standards contain provisions, which through reference in this text, constitute provisions of this standard. At the time of publication, the editions indicated were valid. All standards are subject to revision and parties to agreements based on this standard are encouraged to investigate the possibility of applying the most recent editions of the standards indicated below:

1. IS 9211 : 2003 Terms and definitions of weights of road vehicles other than two and three wheeler (second revision)
2. IS 14272 (Part 1) : Automotive vehicles — Types
3. IS 12832 : 2010 (Reaffirmed 2016) Automotive Vehicles — Interior Noise — Method Of Measurement And Requirements
4. Recommendatory Urban Bus Specifications (UBS) – II, April 2013, Ministry of Urban Development, Government of India
5. European Union (EU) Directive 2002/44/EC
6. IS 13276 (Part 1) : 2000 Mechanical Vibration and Shock - Evaluation of - Human Exposure to Whole Body Vibration

2.0 MEASURED QUANTITIES

Root mean square (rms), Vibration levels in ‘m/s²’ at different vehicle operating conditions.

3.0 MEASURING INSTRUMENTS

3.1 Vibration Measurements

Tri-axial seat pad accelerometer shall be used for measuring the vibration level at driver and passenger seat location. Uni-axial accelerometer shall be used for measuring the vibration level at gangway. Accelerometer should capture at least frequency range 0.4 Hz to 80 Hz for human health, comfort and perception (please refer IS 13276 (Part1): 2000 – clause 1). Data shall be acquired in this frequency range for at least 1 minute or for 0.5 km distance for each speed.

The accelerometer must be calibrated according to the manufacturer’s instructions by means of an appropriate reference source.

3.2 Speed Measurements

The engine speed and vehicle speed shall be determined with an accuracy of ± 3 percent during testing.

4.0 TEST TRACK CONDITIONS

Test track conditions shall be as given below:

- 4.1 Interior vibration levels of motor vehicles are greatly influenced in general by the macro texture of Surface roughness of the road, with smooth road surfaces producing consistent interior levels.

Accordingly, the test road shall be hard and as smooth and levelled as possible, without gaps or ripples or similar macro-texture of surface roughness which might contribute to the interior vibration levels of the motor vehicle.

The surface shall be dry and free from snow, dirt, stones, leaves, etc.

- 4.2 The test track shall allow a steady speed to be maintained. It shall be in a straight line or form a closed circuit with at least 2 000 m length and having a minimum radius of 200 m. The measurement shall not be carried out on banking section of tracks.

5.0 VEHICLE CONDITIONS

- 5.1 Engine and Tyre Conditions

Prior to test, the vehicle shall be run-in as per vehicle manufacturers' recommendation. The vehicle's tyres must be of the type normally fitted to such vehicles by the manufacturer and must be inflated to the appropriate pressure(s) for the unladen vehicle. Before the measurements are made, the engine must be brought to its normal operating condition as regards temperatures, settings, fuel, spark plugs, carburetor(s), etc. (as appropriate).

- 5.2 **Loading of the Vehicle**

The vehicle shall be tested in unladen condition. Only standard vehicle equipment, measuring equipment and necessary personnel shall occupy the interior of the vehicle. Not more than two persons (the driver and observer) shall be present, and in M3 category buses with more than eight seats not more than three persons may be present.

For vehicles with drive-away chassis submitted for test, the compliance to 5.4.1 and 8 shall be established based on a prototype model/mock-up sample, representing completely built vehicle submitted by the vehicle manufacturer.

- 5.3 **Openings, Windows, Auxiliary Equipment, Adjustable Seats**

- 5.3.1 Openings such as skylights, all windows and ventilating inlets and/or outlets shall be shut if possible, unless their influence upon the vibration level inside the vehicle is to be investigated.

5.3.2 Auxiliary equipment such as windscreen wipers, heating and/or ventilating fans and air conditioners shall not operate during the tests. If any auxiliary equipment is automatic in operation, its operating condition shall be stated in the test report.

5.3.3 Adjustable seats shall be set in the mid position of the horizontal and vertical range of adjustments.

5.4 **Vehicle Operating Conditions**

The vehicle operating conditions shall be such as to typify the inside vibration under whichever of the following conditions are appropriate for the vehicle under test:

a) Steady speeds (see 5.4.1);

b) Full throttle acceleration (maximum accelerator position) (see 5.4.2); and

c) Vehicle stationary, with engine idling and full throttle (see 5.4.3),

as an additional monitoring test for commercial vehicles and buses with diesel engines. The corresponding operating conditions are specified in 5.4.1, 5.4.2 and 5.4.3.

5.4.1 Steady Speed

5.4.1.1 Test vehicle speed

The test shall be carried out with increments of 20 km/h starting from 40 km/h to 80 percent of the maximum speed. If the maximum speed of the test vehicle is below 120 km/h, the test speed shall be 80 percent of its maximum speed.

For a vehicle with the maximum vehicle speed below 40 km/h, the test shall be done at 80 percent of its maximum speed. The vehicle speed shall be maintained within ± 3 percent of each test speed.

5.4.1.2 Gear position of transmission

The highest possible gear (including that of auxiliary transmission) that allows the stable running of the test vehicle shall be used for each test speed. If the test vehicle is capable of selecting 4-wheel drive or 2-wheel drive the vehicle shall be run with the 2-wheel drive.

Vibration levels are to be determined at least three speeds to cover the range specified above.

5.4.2 Full Throttle Acceleration (Maximum Accelerator Position)

The procedure for the acceleration test is as follows:

- a) Speed of the vehicle and of the engine shall be stabilized at specified initial conditions;
- b) When stable conditions are attained, the throttle shall be fully opened as quickly as possible and vibration recording shall be made until either 90 percent of the engine speed for maximum power as specified by the manufacturer of the vehicle (in the following test, referred to as maximum power speed) or 120 km/h is reached, whichever is lower. Wheel slip shall be avoided.

The initial operating conditions shall be specified as follows:

- a) Transmission setting shall be the highest position making the test possible without exceeding 120 km/h;
- b) Setting shall not be changed during the test;
- c) If, at an engine speed of 90 percent of maximum power speed, a road speed of 120 km/h is exceeded in top gear, a lower gear shall be selected, but no lower than third for a four-or five-speed gear-box, and no lower than second for a three-speed gearbox.

If 120 km/h is still exceeded in this lower gear, the vehicle shall be tested over the speed range 60 to 120 km/h in that gear;

- d) If possible, kick-down mechanisms shall be made in-operative;
- e) Initial engine speed shall be the lowest allowing a continuously increasing engine speed during the test, but no lower than 45 percent of the maximum power speed, unless 120 km/h is exceeded at 90 percent of maximum power speed in the lowest gear allowed, in which case the initial engine speed shall be that corresponding to a road speed of 60 km/h;
- f) For vehicle with automatic transmission, the initial engine speed shall be stabilized as near as possible to 45 percent of the maximum power speed. The corresponding road speed shall be not higher than approximately 60 km/h.
- g) For vehicles with automated manual transmission, speed of the vehicle and of the engine shall be stabilized at specified initial conditions. When stable conditions are attained, the throttle shall be fully opened as quickly as possible and vibration recording shall be made until either 90 percent of the engine speed for maximum power as specified by the manufacturer of the vehicle or 120 km/h is reached, whichever is lower. Wheel slip shall be avoided.

If, for vehicles with automatic transmissions, the setting changes before the final speed of 90 percent of maximum power speed of 120 km/h is reached the initial speed shall be 50 percent of that speed where the setting changes.

NOTE — Since difficulties in controlling engine speeds may be encountered in vehicles fitted with torque converters, the test condition should be adhered to as closely as practicable.

5.4.3 Stationary Test

The procedure for the stationary test which shall be carried out in neutral gear is as follows:

- a) Engine shall be operated at the low speed idle; and
- b) Throttle shall be fully opened as quickly as possible allowing the engine to accelerate to high idle and shall be held fully open for at least 5 second.

6.0 ACCELEROMETER POSITIONS

The vibration inside a vehicle may vary considerably with location. Therefore, measuring points should be selected in sufficient number and in such a manner that the distribution of the vibration in the vehicle is adequately represented with respect to driver and passenger seating locations.

- 6.1 One measuring point shall be at the driver's seat. Additional measuring points shall be for the rear passenger seats of vehicle adjacent to the longitudinal axis of the vehicle.
- 6.2 For a vehicle with three or more than three rows of seats the interior vibration shall be measured with the accelerometer position at the following three positions. Driver's seat as the first position, second position at the middle row of the multiple seat rows and third position at the last row of seats for the seat positions nearest to the longitudinal axis of the vehicle.
- 6.3 Similarly, for a vehicle with three or more than three rows of seats the gangway vibration shall be measured with the uni-axial accelerometer position at the following three positions. Front, middle and rear zone of the vehicle covering the entire length of the gangway.
- 6.4 During the measurement no person shall occupy the selected position with the exception of seat vibration locations. The accelerometers shall be mounted in the orientation of vehicle level Cartesian coordinates (XYZ).

7.0 TEST PROCEDURE

- 7.1 At the steady speeds, the values of the root mean square (rms) vibration level are recorded for at least three speeds as specified in 5.4.1.
- 7.2 At full throttle acceleration (see 5.4.2), the maximum value of the overall vibration level occurring in the specified acceleration range is retained and stated in the test report.
- 7.3 In the stationary test, the values of the root mean square (rms) vibration level shall be recorded when the testing is carried out as specified in 5.4.3.
- 7.4 At least two measurements shall be made at each accelerometer position and for each operating condition. If the spread of results of the vibration levels obtained under any measuring condition exceeds 20% deviations, further measurements shall be made until the readings of two independent successive measurements fall within a range of 20%; the mean value of these two readings shall be recorded as the test result. The values stated in the test report shall be rounded to the nearest integral decibel.

Any peak which is obviously out of character with the general vibration level being read should be ignored.

8.0 TEST REPORT

The test report shall include the following information:

Sr. No.	Parameters to be Included in Test Report
i	Nature of tests
ii	Test site
iii	Measuring equipment
iv	Vehicle details, including, a) its engine / motor b) settings of gearbox c) speed during tests d) tyre sizes e) tyre pressures f) radiator-flaps (blinds)
v	Adjustable seats with reference to 6.3.3
vi	Unladen weight of the vehicle
vii	No. of persons in the vehicle
viii	Accelerometer positions
ix	The root mean square vibrations level at specified accelerometer positions

9.0 TECHNICAL SPECIFICATIONS OF VEHICLE TO BE SUBMITTED BY THE VEHICLE MANUFACTURER

The technical specification of vehicle as relevant to interior vibration shall be declared by vehicle manufacturer and shall contain at least the following:

<ul style="list-style-type: none"> a) Model name/Variant(s) b) Category of vehicle c) Unladen weight d) Fully built or partially built or only with cabin e) Setting of gear box <ul style="list-style-type: none"> i) Type of gear box — MT/AT/CVT ii) No. of forward gears iii) Maximum speeds in different gear iv) Transmission ratio v) Axle ratios
<ul style="list-style-type: none"> f) Engine / Motor: power-torque characteristics <ul style="list-style-type: none"> i) Engine / Motor type ii) Capacity iii) Number of arrangement of cylinders iv) Fuel used
g) Tyre sizes and tyre pressures
h) Interior length / seating layout
NOTE — If the specifications submitted for complete type approval of a vehicle contain the details given above, there is no necessity of submitting this information again

10.0 MODIFICATIONS/CHANGES

In case test is conducted for verification of compliance to statutory requirements the following procedure shall be followed:

- 10.1 Every functional modification pertaining to the information declared in accordance with 9 shall be intimated by the manufacturer to the certifying agency. The Testing Agency may then consider, whether, the model with the changed specifications still complies with provisions; or any further verification is required to establish compliance. For considering whether any further verification is required or not, guidelines given in 11.0 may be followed.

- 10.2 In case of any further verification is required to establish compliance, tests for only those parameters which are affected by the modifications need to be carried out.
- 10.3 In case of fulfillment of results of further verification as per 10.2, the approval of compliance shall be extended for the changes carried out.
- 10.4 These conditions are applicable irrespective of any change in commercial name of the vehicle model.

11.0 CRITERION FOR EXTENSION OF APPROVAL (CEA)

- 11.1** This clause gives the factors to be considered while selecting a vehicle to represent a range of variants for establishing compliance of a model for type approval to meet the test requirements of 8 for test conducted as per 5.4.1.

This also applies to,

- a) Extension of type approval for changes in technical specifications of an already type approved model; and
- b) Establishing compliance of new model/ variant(s) based on already type approved model.

- 11.2** In case of following changes, the verification shall be carried out for establishing compliance of the changed parameters to the requirements specified in this standard. The following is applicable only for the verification as per 5.4.1:

- a) In case of change in engine type, capacity, number and arrangement of cylinders, test needs to be conducted for compliance.
- b) In case of change in base diesel engine to Petrol, CNG or LPG or base petrol engine to CNG or LPG keeping the power within the tolerance specified below, no test needs to be conducted for compliance:
 - i) In case of increase in rated engine power upto 10 percent or any decrease of rated engine power;
 - ii) In case of increase in rated engine speed upto 10 percent or any decrease of rated engine speed;
 - iii) In case of any changes in transmission ratios, axle ratios and type, size and ply rating of tyres;
 - iv) In case of any increase in the interior length or a decrease in interior length by less than 10 percent;
 - v) In case of any decrease in the maximum fan tip speed or an increase in the fan tip speed up to 10 percent;
 - vi) In case of any decrease in the blades or an increase in the number of blades up to 30 percent (rounded off to nearest whole number, as per Indian Standard);
 - vii) In case of change in the fan drive from mechanical to either viscous or

electrical or from viscous to electrical;

- viii) In case of any change in fan shroud, blade material, thickness, profile and design details; and
- ix) Changes other than the above are considered as not affecting compliance and do not call for any test.

ANNEXURE III

(See 2.4.1.3)

AUTOMOTIVE VEHICLES — INTERIOR HARSHNESS — METHOD OF MEASUREMENT AND REQUIREMENTS**1.0 REFERENCES**

The following standards contain provisions, which through reference in this text, constitute provisions of this standard. At the time of publication, the editions indicated were valid. All standards are subject to revision and parties to agreements based on this standard are encouraged to investigate the possibility of applying the most recent editions of the standards indicated below:

1. IS 9211 : 2003 Terms and definitions of weights of road vehicles other than two and three wheeler (second revision)
2. IS 14272 (Part 1) : Automotive vehicles — Types
3. Recommendatory Urban Bus Specifications (UBS) – II, April 2013, Ministry of Urban Development, Government of India
4. IS 13276 (Part 1) : 2000 Mechanical Vibration and Shock - Evaluation of - Human Exposure to Whole Body Vibration
5. IRC: 99-1988 : Tentative Guidelines on the Provision of Speed Breakers for Control of Vehicular Speeds on Minor Roads.
6. IS 12832 : 2010 (Reaffirmed 2016) Automotive Vehicles — Interior Noise — Method Of Measurement And Requirements.

2.0 MEASURED QUANTITIES

Transient (running rms) Vibration levels at driver and passengers seating area in 'g'.

3.0 MEASURING INSTRUMENTS**3.1 Vibration Measurements**

Tri-axial seat pad accelerometer shall be used for measuring the vibration level at driver and passenger seat locations. Accelerometer should capture at least frequency range 0.4 Hz to 80 Hz for human health, comfort and perception (Please refer IS 13276 (Part1): 2000 – clause 1).

At the beginning and end of each series (full set) of measurements, the accelerometer must be calibrated according to the manufacturer's instructions by means of an appropriate reference source.

3.2 Speed Measurements

The vehicle speed shall be determined with an accuracy of ± 3 percent during testing.

4.0 TEST TRACK CONDITIONS

Test track conditions shall be as given below:

- 4.1 Interior vibration levels of motor vehicles are greatly influenced in general by the macro texture of Surface roughness of the road, with smooth road surfaces producing consistent interior levels.

Accordingly, the test road shall be hard and as smooth and levelled as possible, without gaps or ripples or similar macro-texture of surface roughness which might contribute to the interior vibration levels of the motor vehicle.

The surface shall be dry and free from snow, dirt, stones, leaves, etc.

- 4.2 The test track shall allow a steady speed to be maintained. It shall be in a straight line with at least 2000 m length and having a minimum radius of 200 m. The measurement shall not be carried out on banking section of tracks.

5.0 VEHICLE CONDITIONS

5.1 Engine and Tyre Conditions

Prior to test, the vehicle shall be run-in as per vehicle manufacturers' recommendation. The vehicle's tyres must be of the type normally fitted to such vehicles by the manufacturer and must be inflated to the appropriate pressure(s) for the unladen vehicle. Before the measurements are made, the engine must be brought to its normal operating condition as regards temperatures, settings, fuel, spark plugs, carburetor(s), etc. (as appropriate).

5.2 Loading of the Vehicle

The vehicle shall be tested in unladen condition. Only standard vehicle equipment, measuring equipment and necessary personnel shall occupy the interior of the vehicle. Not more than two persons (the driver and observer) shall be present, and in M3 category buses with more than eight seats not more than three persons may be present.

For vehicles with drive-away chassis submitted for test, the compliance to 6.4 and 8.0 shall be established based on a prototype model/mock-up sample, representing completely built vehicle submitted by the vehicle manufacturer.

5.3 Openings, Windows, Auxiliary Equipment, Adjustable Seats

- 5.3.1 Openings such as skylights, all windows and ventilating inlets and/or outlets shall be shut if possible, unless their influence upon the vibration level inside the vehicle is to be investigated.

- 5.3.2 Auxiliary equipment such as windscreen wipers, heating and/or ventilating fans and air conditioners shall not operate during the tests. If any auxiliary equipment is automatic in operation, its operating condition shall be stated in the test report.

- 5.3.3 Adjustable seats shall be set in the mid position of the horizontal and vertical range of adjustments.

5.4 Vehicle Operating Conditions

Vibration level at driver and passenger seat locations shall be measured while the vehicle is accelerated from 0 to 50 km/h and coasted down from 50 to 10 km/h in wide open throttle condition.

The highest possible gear (including that of auxiliary transmission) that allows the stable running of the test vehicle shall be used for test speed. If the test vehicle is capable of selecting 4-wheel drive or 2-wheel drive the vehicle shall be run with the 2-wheel drive.

6.0 ACCELEROMETER POSITIONS

The vibration inside a vehicle may vary considerably with location. Therefore, measuring points should be selected in sufficient number and in such a manner that the distribution of the vibration in the vehicle is adequately represented with respect to driver and passenger seating locations.

- 6.1 One measuring point shall be at the driver’s seat. Additional measuring points shall be for the rear passenger seats of vehicle adjacent to the longitudinal axis of the vehicle.
- 6.2 For a vehicle with three or more than three rows of seats the seat vibration shall be measured with the accelerometer position at the following three positions. Driver’s seat as the first position, second position at the middle row of the multiple seat rows and third position at the last row of seats for the seat positions nearest to the longitudinal axis of the vehicle.
- 6.3 During the measurement no person shall occupy the selected position with the exception of seat vibration locations. The accelerometers shall be mounted in the orientation of vehicle level Cartesian coordinates (XYZ).

7.0 TEST PROCEDURE

Vibration level at driver and passenger seat locations shall be measured while the vehicle is accelerated from 0 to 50 km/h and coasted down from 50 to 10 km/h in wide open throttle condition. At least two measurements shall be made at each accelerometer position. If the spread of results of the vibration levels obtained under any measuring condition exceeds 20% deviations, further measurements shall be made until the readings of two independent successive measurements fall within a range of 20%; the mean value of these two readings shall be recorded as the test result. The values stated in the test report shall be rounded to the nearest integral decibel.

Any peak which is obviously out of character with the general vibration level being read should be ignored.

8.0 TEST REPORT

The test report shall include the following information:

Sr. No.	Parameters to be Included in Test Report
i	Nature of tests
ii	Test site
iii	Measuring equipment
iv	Vehicle details, including,
	a) its engine / motor

	b) settings of gearbox
	c) speed during tests
	d) tyre sizes
	e) tyre pressures
	f) radiator-flaps (blinds)
v	Adjustable seats with reference to 6.3.3
vi	Unladen weight of the vehicle
vii	No. of persons in the vehicle
viii	Accelerometer positions
ix	The maximum transient vibration level at specified accelerometer positions

9.0 TECHNICAL SPECIFICATIONS OF VEHICLE TO BE SUBMITTED BY THE VEHICLE MANUFACTURER

The technical specification of vehicle as relevant to interior vibration shall be declared by vehicle manufacturer and shall contain at least the following:

a) Model name/Variant(s)
b) Category of vehicle
c) Unladen weight
d) Fully built or partially built or only with cabin
e) Setting of gear box
i) Type of gear box — MT/AT/CVT ii) No. of forward gears iii) Maximum speeds in different gear iv) Transmission ratio v) Axle ratios
f) Engine / Motor : power-torque characteristics
i) Engine / Motor type ii) Capacity iii) Number of arrangement of cylinders iv) Fuel used
g) Tyre sizes and tyre pressures
h) Interior length / Seating Layout

NOTE — If the specifications submitted for complete type approval of a vehicle contain the details given above, there is no necessity of submitting this information again

10 MODIFICATIONS/CHANGES

In case test is conducted for verification of compliance to statutory requirements the following procedure shall be followed:

- 10.1 Every functional modification pertaining to the information declared in accordance with 9 shall be intimated by the manufacturer to the certifying agency. The Testing Agency may then consider, whether, the model with the changed specifications still complies with provisions; or any further verification is required to establish compliance. For considering whether any further verification is required or not, guidelines given in 11 may be followed.
- 10.2 In case of any further verification is required to establish compliance, tests for only those parameters which are affected by the modifications need to be carried out.
- 10.3 In case of fulfillment of results of further verification as per 10.2, the approval of compliance shall be extended for the changes carried out.
- 10.4 These conditions are applicable irrespective of any change in commercial name of the vehicle model.

11.0 CRITERION FOR EXTENSION OF APPROVAL (CEA)

- 11.1 This clause gives the factors to be considered while selecting a vehicle to represent a range of variants for establishing compliance of a model for type approval to meet the test requirements of 2.4 of this standard for test conducted as per 5.4.

This also applies to,

- a) Extension of type approval for changes in technical specifications of an already type approved model; and
 - b) Establishing compliance of new model/ variant(s) based on already type approved model.
- 11.2 In case of following changes, the verification shall be carried out for establishing compliance of the changed parameters to the requirements specified in this standard. The following is applicable only for the verification as per 5.4:
 - a) In case of change in engine type, capacity, number and arrangement of cylinders, test needs to be conducted for compliance.
 - b) In case of change in base diesel engine to Petrol, CNG or LPG or base petrol engine to CNG or LPG keeping the power within the tolerance specified below, no test needs to be conducted for compliance:
 - 1) In case of increase in rated engine power upto 10 percent or any decrease of rated engine power;

- 2) In case of increase in rated engine speed upto 10 percent or any decrease of rated engine speed;
- 3) In case of any changes in transmission ratios, axle ratios and type, size and ply rating of tyres;
- 4) In case of any increase in the interior length or a decrease in interior length by less than 10 percent;
- 5) In case of any decrease in the maximum fan tip speed or an increase in the fan tip speed up to 10 percent;
- 6) In case of any decrease in the blades or an increase in the number of blades up to 30 percent (rounded off to nearest whole number, as per Indian Standard);
- 7) In case of change in the fan drive from mechanical to either viscous or electrical or from viscous to electrical;
- 8) In case of any change in fan shroud, blade material, thickness, profile and design details; and
- 9) Changes other than the above are considered as not affecting compliance and do not call for any test.

ANNEXURE IV

(See clause 2.7)

Multiplexing/Electronic Architecture Requirements

These test standard compliances are common to multiplexing nodes
(PIS signs/controller/driver console, (if fitted))

1.0	Architecture-multi 'Node'
a	Each node with its own microprocessor (16 bit minimum)
b	Internal communication on CAN 2B
c	At least one node shall have outputs suitable for
	i Resistive loads, Coil loads, relay loads PWM
	ii Current measurement, short circuit detection, open load detection and over Current Protection.
	iii Digital high side
d	At least one node shall have Inputs suitable for
	(1) Analog
	(2) Digital high/low side
	(3) for frequency/pulse counting
e	Each node to be IP54 certified and to comply with test standards as specified in Table 1 below

Table 1

Sr. No	Test standards compliance	Specifications
1	Performance parametric test	Nine points, tri temperature/tri voltage- 18V, 27V, 32V,-25°C, room temperature, +80°C test. At each test point the system will be powered on and shut down 5 times as per the supplier's designated procedure and thereafter evaluated for malfunction if any
2	Cold	IS 9000 (Part II/Sec 4)-1977 (reaffirmed 2004) at -15°C for 2 hours in 'on' condition
3	Dry heat	IS 9000 (Part III/Sec 5)-1977: PIS Signs, SCU and Nodes at + 80°C for 16 hours in 'on' condition. BDC at + 80°C for 2 hours
4	Damp heat	IS 9000 (Part V/Sec 2)1981 at +25°C /+55°C, Humidity 95%, 24 hours for 6 cycles in off condition. Functional test with power in 'on' condition at start of 2nd, 4th and 6th cycle
5	Vibration standard AIS 012/AIS:062 -10g	Frequency 5~ 55 Hz and return to 5Hz at a linear sweep period of 1 minute/complete sweep cycle with 1.65 mm pk-pk displacement and maximum acceleration of 10g. Test duration 60 minutes Direction of vibration –X, Y, Z axis of device as it is mounted on the vehicle. For 10 g acceleration, frequency range need to be 5-55 Hz
6	Dust and water ingress protection	IS /IEC 60947-1:2004 in conjunction with IS/IEC 60529:2001– 'PIS signs' IP66, 'SCU' IP 65, 'BDC' IP65, 'nodes' IP54
7	Free fall	IS 9000 (Part VII/Sec 4) Free fall at 500 mm ,(applicable to 'nodes' and 'controllers')(only)
8	Fire resistant	Regulation directive 95-28/EG dated 24-10-1995 horizontal Burning rate tested as per ISO 3795. Horizontal burning test HB as per UL 94 -1998 clause 7 (for wire harness)
9	Reverse polarity protection without fuse	The component must fulfil the function- and service life requirements after being subjected to reversed polarity up to 27 V for 2 minutes.
10	Over voltage protection	To ensure service life requirements and functionality. The component shall run for 60 minutes at 38V, without effecting the service life or function.

11	Insulation resistance	Insulation resistance test will be carried out after completion of 'Damp Heat Test' and then test samples to be kept at room temperature for atleast 0.5 hrs.
12	Cranking voltage	The components shall have an electrical energy reserve that can handle voltage drop during cranking. Component shall not reset during cranking- 'FSC B'. The supply voltage during crank is 18.0 V for 40 ms. The test to be carried out as per ISO 7637
13	Load dump test on controller	123V , 8 Ohms 200ms pulse 5a as per standard ISO 7637-2.After test DUT shall meet at least class B as per ISO 7637-2
14	Salt spray test	(AIS: 012/ IS10250) 96 hours
15	EMC/EMI	1.Electromagnetic radiation, radiated immunity and compatibility as per AIS 004 (Part 3) or 2.72/245/EEC last amended by 2009/19/EC (includes 2004/104/EC, 2005/83/EC, 2006/96/EC) and UN ECE Regulation Number 10 Rev 3:2008
		Note: In case of product is 'e' marked and a detailed test report is submitted (which includes above tests) no fresh verification is necessary
16	Operating parameters	Supply voltage 24 V \pm 25%
17	LED color test – dominant wave length amber, if fitted	AIS-010 (Part 5)(Rev.1):2010
18	LED chromaticity coordinates, if fitted	AIS-010 (Part 5)(Rev.1):2010
19	LED bulb/SMT intensity and viewing angle, if fitted	In accordance with CIE 127 condition B

ANNEXURE V**ACCOMODATION AND ACCESSIBILITY FOR PASSENGERS WITH
REDUCED MOBILITY****1.0 GENERAL**

This annexure contains the provisions which apply to a bus designed for easy access for passengers with reduced mobility and wheelchair users.

2.0 SCOPE

These requirements shall apply to buses permitting easier access for persons with reduced mobility.

3.0 REQUIREMENTS**3.1 Steps**

The height of the first step from the ground of at least one service door shall not exceed 250 mm for Type I, 300 mm for buses of Type I with mini capacity and 320mm for buses of Types II, III. In the case where only one service door meets this requirement there shall be no barrier or sign which prevents that door from being used as both an entrance and an exit.

In low floor buses only a kneeling system, but not a retractable step, may be engaged. In other buses either a kneeling system and/or a retractable step may be engaged.

The height of steps in an access passage at the above-mentioned door(s), and throughout the entire gangway, shall be not more than 200 mm for buses of Type I and 250 mm for buses of Types II, III with midi and standard capacity.

The transition from a sunken gangway to a seating area shall not be considered to be a step.

3.2 Priority Seats and Space for Passengers with Reduced Mobility

3.2.1 Seats shall be either forward or rearward facing and shall be situated in a position near to a service door(s) suitable for boarding and alighting and compliant with Paragraph 3.1. above.

3.2.2 There shall be adequate space for a guide dog under, or adjacent to, at least one of the priority seats. This space shall not form a part of the gangway

3.2.3 Armrests shall be fitted on seats between the seating position and the gangway and shall be capable of being moved easily out of the way to permit clear access to the seat. In the case of seats facing each other, one of the gangway seats may alternatively be fitted with a vertical stanchion. This stanchion shall be positioned so that the seat occupant is kept securely on the seat and easy access to the seat is possible.

3.2.4 The minimum width of a priority seat cushion, measured from a vertical plane passing through the centre of that seating position, shall be as per AIS-052(Rev.1), as amended from time to time

- 3.2.5 The height of the uncompressed seat cushion relative to the floor shall be such that the distance from the floor to a horizontal plane tangent to the front upper surface of the seat cushion is between 400 mm and 500 mm.
- 3.2.6 The foot space at priority seating positions shall extend forward of the seat from a vertical plane through the forward edge of the seat cushion. The foot space shall not have a slope in any direction of more than 8%. For buses of Type I , the vertical distance between the floor of the seating area and the adjacent gangway shall be not more than 250 mm.
- 3.2.7 Each priority seating position shall have a free height of not less than 1,300 mm for buses of Type I and 900 mm for buses of Type II, measured from the highest point of the uncompressed seat cushion. This free height shall extend over the vertical projection of the minimum required seat width of 440 mm and the associated footspace.

Intrusion of a seat back or other object into this space shall be permitted provided that a minimum clear vertical space extending 230 mm in front of the seat cushion is maintained. Where the priority seat is positioned facing a bulkhead more than 1,200 mm in height this space shall be 300 mm. From the edges of the free space defined above, intrusions are permitted in accordance with paragraphs 3.2.7.1 to 3.2.7.4 of this Annexure as if reference to the clear space in Paragraphs 3.2.7.5 and 3.2.7.6 of this Annexure is a reference to the clear space defined above. The provisions of Paragraph 3.2.7.7 of this Annexure may apply. Intrusions of handholds or handrails as mentioned in Paragraph 3.4.2. below may protrude by a maximum of 100 mm from the sidewall into the clear space over the vertical projection of the foot space.

- 3.2.7.1 In the case of the upper part of the outboard seats, adjacent to the inner wall of the bus, a zone with a rectangular cross-section 150 mm in height and 100 mm in width (See Fig.1 to this Annexure).

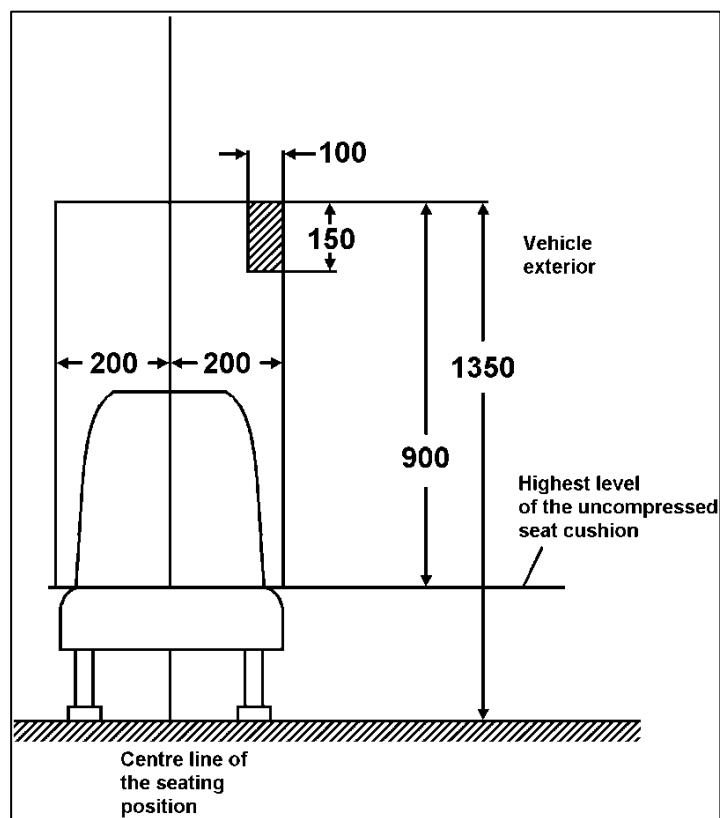
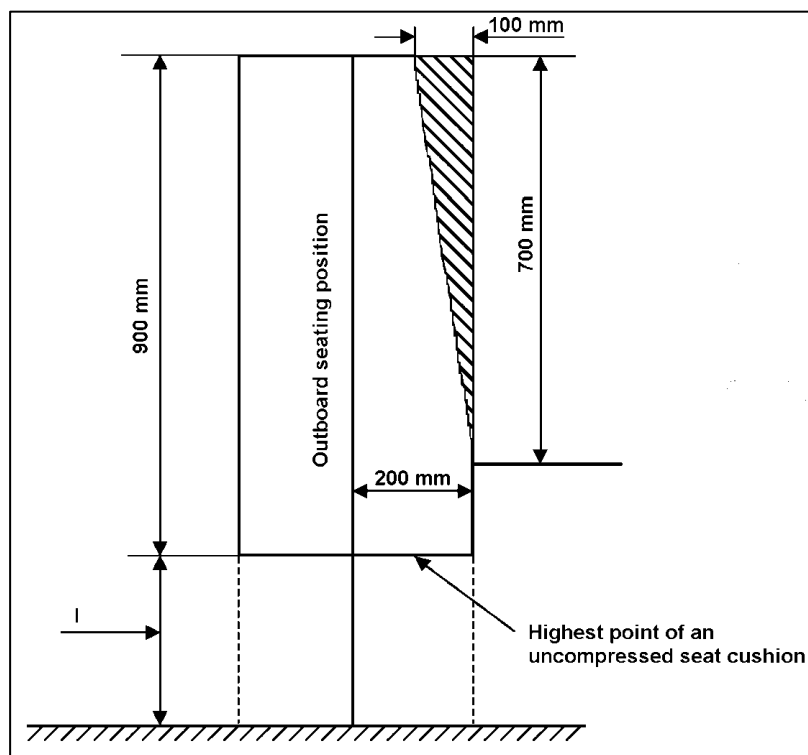

Figure 1

Permitted Intrusion into Space above Seat Transversal Section of the Minimum Free Space above a Seating Place Adjacent to the Wall of the Bus

- 3.2.7.2 In the case of the upper part of outboard seating position, a zone with triangular cross-section whose apex is situated 700 mm from the top and whose base is 100 mm in width (See Fig. 2 to this Annexure). The space needed for safety belts and their anchorages and for the sun visor is also excluded.



I (mm)
400 to 500
(for Classes A, B, I and II min 350mm at wheel arches and engine compartment(s))

Figure 2

Permitted Intrusion above a Seating Position

- 3.2.7.3 In the case of the foot well of an outboard seating position, a zone of a cross-sectional area not exceeding, 0.02m^2 (0.03m^2 for low floor buses) and having a maximum width not exceeding 100 mm (150 mm for low floor buses) (See Fig.3 to this Annexure).

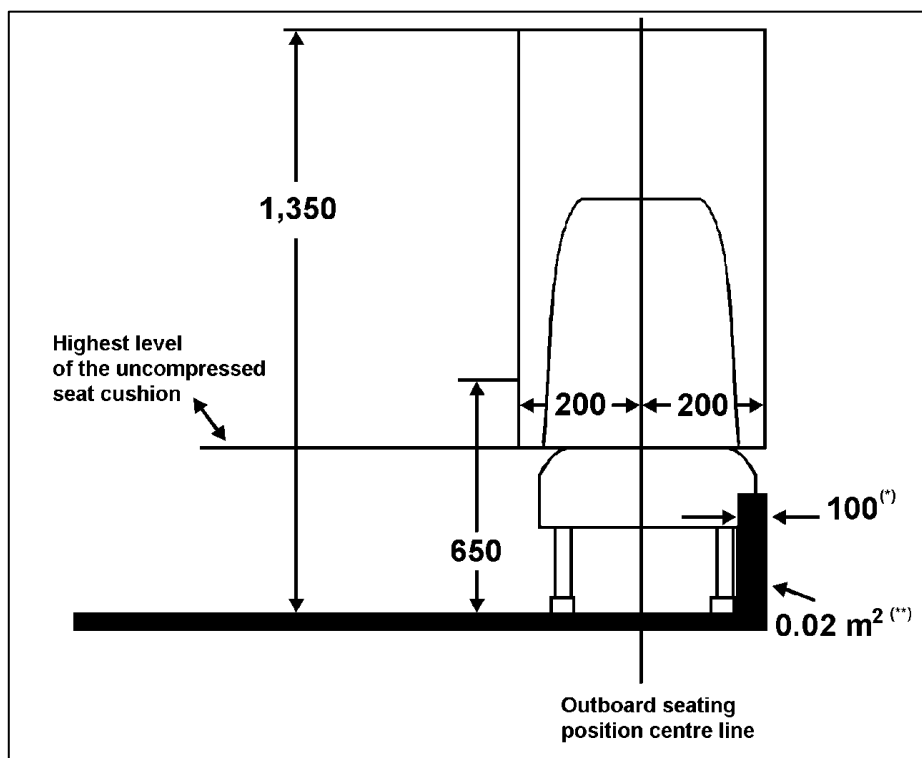

(*) 150mm in the case of low-floor buses.

(**) 0.03m² in the case of low floor buses.

Figure 3

Permitted Intrusion in Lower Part of Passenger Space

- 3.2.7.4 In the case of a bus for up to 22 passengers, in the case of the seating places nearest to the rear corners of the body, the outer rear edge of the free space, viewed in plan, may be rounded to a radius not exceeding 150 mm (See Fig.4 to this Annexure).

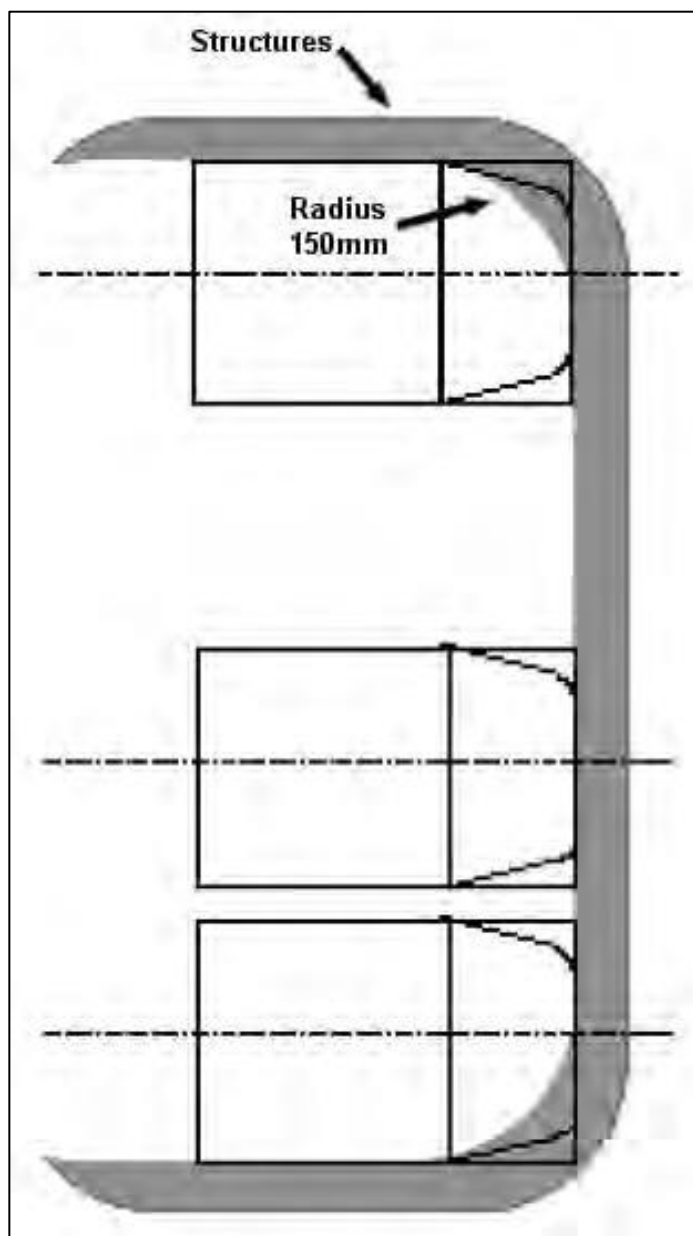

Figure 4
Permitted Intrusion at Rear Corner Seats
View of the Prescribed Area of the Seat
(Two Side Seats at the Rear)

- 3.2.7.5 In the case of single deck buses, over each seating position and, except in the case of the seat(s) alongside the driver in a bus with mini capacity, its associated foot space, there shall be measured a free space with a height of not less than 900 mm measured from the highest point of the uncompressed seat cushion and at least 1,350 mm from the mean level of the floor in the foot space. In the case of buses to which Paragraphs 2.2.6, 2.2.8 and 2.2.11 of AIS-052(Rev.1), 3.2.7.5.1 of this Annexure applies and also for the seat(s) alongside the driver in a bus of mini capacity or

Midi or Standard capacity , these dimensions may be reduced to 1,200mm measured from the floor and 800mm measured from the highest point of the uncompressed seat cushion.

- 3.2.7.6 This free space shall be extended over the zone defined:
- 3.2.7.6.1 By longitudinal vertical planes 200mm either side of the median vertical plane of the seating position, and
- 3.2.7.6.2 By a transverse vertical plane through the rearmost upper point of the seat back and by a transverse vertical plane 280mm in front of the foremost point of the uncompressed seat cushion, measured in each case at the median vertical plane of the seating position.
- 3.2.7.7 For buses having a capacity not exceeding 22 passengers, in the case of seats adjacent to the wall of the bus, the available space does not include, in its upper part, a triangular area 20mm wide by 100mm high (See Fig.5 to this Annexure). In addition, the space needed for safety belts and their anchorages and for the sun visor should be considered as exempted.

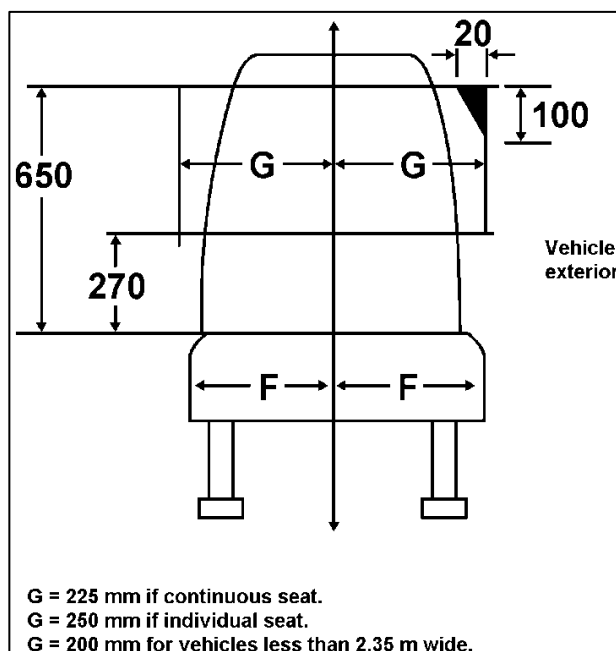

Figure 5

Permitted Intrusion at Shoulder Height Transversal Section of the Minimum Available Space at Shoulder Height for a Seat Adjacent to the Wall of the Bus

- 3.2.8. Buses fitted with a priority seat shall have pictogram(s) (See Fig.6 to this Annexure). visible from the outside, both on the front nearside of the bus and adjacent to the relevant service door(s). A pictogram shall be placed internally adjacent to the priority seat.



Colour: blue basis with white symbol

Size: at least 130 mm diameter

Reference for the design principles of safety symbols: ISO 3864-1:2002

Figure 6

Pictogram for Passengers with Reduced Mobility other than Wheelchair Users

3.3 Communication Devices

3.3.1 Communication devices shall be placed adjacent to any priority seat and within any wheelchair area and shall be at a height between 700 mm and 1,200 mm above the floor.

3.3.2 Communication devices situated in the low floor area shall be at a height between 800mm and 1,500mm where there are no seats.

3.3.3 (Reserved)

3.3.4 If a bus is fitted with a ramp or lift, a means of communication with the driver shall be fitted outside, adjacent to the door, and at a height between 850mm and 1,300mm from the ground. This requirement shall not apply to a door situated in the direct field of vision of the driver.

3.4 Handrails to Priority Seating

3.4.1 A handrail at a height of between 800mm and 900mm above the floor level shall be provided between the priority seats as described in Paragraph 3.4.1.1 and at least one service door suitable for boarding and alighting. A break is permitted where it is necessary to gain access to a wheelchair space, a seat located at a wheel arch, a staircase, an access passage or a gangway. Any break in the handrail shall not exceed 1,050mm and a vertical handrail shall be provided on at least one side of the break.

3.4.1.1 The minimum number of priority seats complying with the requirements of paragraph 3.2. shall be as per AIS-052(Rev.1)

3.4.2 Handrails or handholds shall be placed adjacent to priority seating positions to facilitate entry and exit of the seat, and shall be designed in such a way as to allow the passenger to grasp them easily.

3.5 **Floor Slope**

The slope of any gangway, access passage or floor area between any priority seat or wheelchair space and at least one entrance and one exit or a combined entrance and exit shall not exceed 8%. Such sloping areas shall be provided with a slip-resistant surface.

3.6 **Wheelchair Accommodation Provisions**

3.6.1 For each wheelchair user provided for in the passenger compartment there shall be a special area at least 750 mm wide and 1,300 mm long. The longitudinal plane of the special area shall be parallel to the longitudinal plane of the bus and the floor surface of the special area shall be slip resistant and the maximum slope in any direction shall not exceed 5%. In the case of a rearward facing wheelchair complying with the requirements specified in Paragraph 3.8.4 of this Annexure, the slope in the longitudinal direction shall not exceed 8% provided that this slope inclines upwards from the front end to the rear end of the special area.

In the case of a wheelchair space designed for a forward facing wheelchair, the top of preceding seat-backs may intrude into the wheelchair space if a clear space is provided (See Fig.7 to this Annexure).

However, wheelchair accommodation provisions shall not be applicable for buses whose Gross Vehicle Weight (GVW) is less than 3.5 tons.

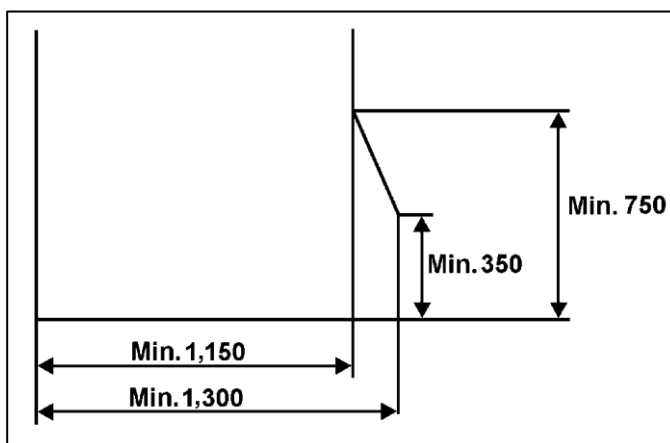

Figure 7
Minimum Clear Space for the Wheelchair User at the Wheelchair Space

3.6.2 There shall be at least one doorway through which wheelchair users can pass. In the case of buses of Type I, at least one wheelchair access door shall be a service door. The wheelchair access door shall bear a boarding device complying with the provisions of Paragraph 3.11.3. (a lift) or 3.11.4. (a ramp) of this Annexure.

3.6.3 A door for wheelchair access, that is not a service door, shall have a minimum height of 1,400 mm. The minimum width of all doors providing wheelchair

access to the bus shall be 900 mm which may be reduced by 100 mm when the measurement is made at the level of handholds.

- 3.6.4 It shall be possible for a wheelchair user to move freely and easily from the outside of the bus through at least one of the doors for wheelchair access into the special area(s) with a reference wheelchair, the dimensions of which are shown. (See Fig. 8 to this Annexure).

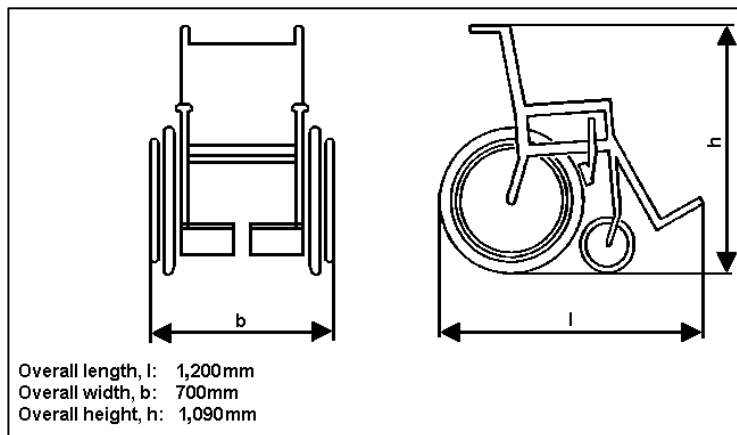

Note:

A wheelchair user seated in the wheelchair adds 50mm to the overall length and makes a height of 1,350mm above the ground

Figure 8
Reference Wheelchair

- 3.6.4.1 By "moving freely and easily", it is meant that there exists:
- 3.6.4.1.1 Sufficient space available for the wheelchair user to manoeuvre without the assistance of a person;
- 3.6.4.1.2 There are no steps, gaps or stanchions which could be an obstacle to the free movement of the wheelchair user.
- 3.6.4.2 For the application of the above provisions, the test shall be performed, in the case of buses of Type I fitted with more than one wheelchair space, for each wheelchair space with all other wheelchair spaces occupied by the reference wheelchair.
- 3.6.5 In buses of Type I fitted with a ramp for wheelchair access, it shall be possible for a reference wheelchair having the dimensions shown (See Fig.9 to this Annexure) to enter and exit a bus with the wheelchair moving in a forward direction.
- 3.6.6 Buses fitted with a wheelchair space shall have pictogram(s) in accordance with Figure (See Fig.9 to this Annexure) visible from the outside, both on the front nearside of the bus and adjacent to the relevant service door(s).

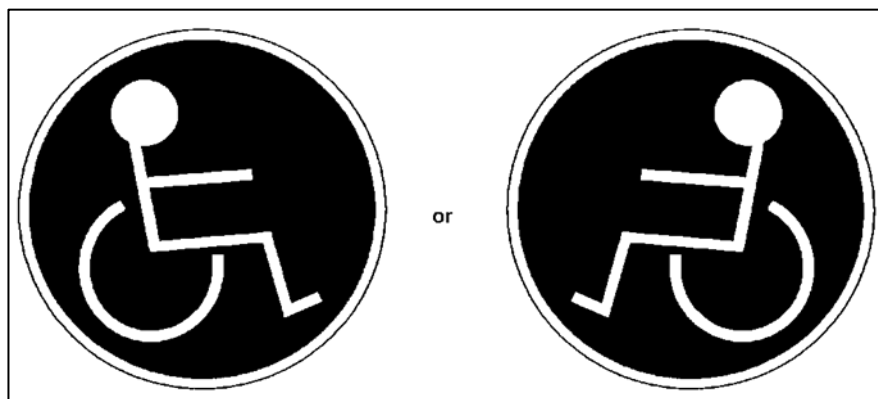

Figure 9
Pictogram for Wheelchair Users

One of these pictograms shall be placed internally adjacent to each wheelchair space indicating whether the wheelchair is to be positioned facing the front or the rear of the bus.

Colour: blue basis with white

symbol Size: at least 130 mm diameter

Reference for the design principles of safety symbols: ISO 3864-1:2002

- 3.7 Seats and Standing Passengers in the Wheelchair Space**
- 3.7.1 Folding seats may be fitted in a wheelchair space. However, such seats when folded and out of use shall not intrude into the wheelchair space.
- 3.7.2 A bus may be equipped with demountable seats fitted in the wheelchair space provided that such seats may be easily removed by the driver or a crew member.
- 3.7.3 For buses of Type I, II, where the foot space of any seat, or part of a folding seat when in use, intrudes into a wheelchair space, those seats shall have signs fixed on or adjacent to them with the following text, equivalent text or pictogram:
"Please give up this space for a wheelchair user".
The provisions of Paragraph 3.7.4.1 of this Annexure shall apply to any textual markings used.
- 3.7.4 In buses where any wheelchair space is designated for use exclusively by a wheelchair user as provided for the surface of any wheelchair space(s) dedicated solely for the use of wheelchair user(s), those spaces shall be clearly marked with the following text, equivalent text or pictogram:
"Area designated for use exclusively by a wheelchair user"
The provisions of Paragraph 3.7.4.1 of this Annexure shall apply to any textual markings used.
- 3.7.4.1 Safety Signs
- 3.7.4.1.1 All safety signs shall meet requirements as specified in clause 3.4.5.5 of AIS-052 (Rev.1)

3.8 Stability of Wheelchairs

3.8.1 In buses required to have occupant restraint systems fitted, the wheelchair space shall be designed for the wheelchair user to travel facing forwards and shall be fitted with restraint systems complying with either the requirements specified in Paragraph 3.8.2. or those specified in Paragraph 3.8.3. below

In buses not required to have occupant restraint systems fitted, the wheelchair space shall be fitted with restraint systems complying with the requirements specified in Paragraph 3.8.2 or 3.8.3., or shall comply with the requirements specified in Paragraph 3.8.4. below.

3.8.2 Forward-facing Wheelchair – Static Test Requirements

3.8.2.1 Each wheelchair space shall be provided with a restraint system capable of restraining the wheelchair and the wheelchair user.

3.8.2.2 This restraint system and its anchorages shall be designed to withstand forces equivalent to the ones required for the passenger seats and occupant restraint systems.

3.8.2.3 A static test shall be carried out in accordance with the following requirements:

3.8.2.3.1 The forces referred hereto shall be applied in forward and rearward directions, separately and on the restraint system itself;

3.8.2.3.2 The force shall be maintained for a period of not less than 0.2 s;

3.8.2.3.3 The restraint system shall be capable of withstanding the test. Permanent deformation, including partial rupture or breakage of the restraint system shall not constitute failure if the required force is sustained for the specified time. Where applicable, the locking device enabling the wheelchair to leave the bus shall be operable by hand after removal of the traction force.

3.8.2.4 In forward direction in the case of a separate wheelchair and wheelchair user restraint system

3.8.2.4.1 For Category M2:

3.8.2.4.1.1 1,110daN \pm 20daN in the case of a lap belt. The force shall be applied on the wheelchair user restraint system in the horizontal plane of the bus and towards the front of the bus if the restraint system is not attached to the floor of the bus. If the restraint system is attached to the floor, the force shall be applied in an angle of $45^\circ \pm 10^\circ$ to the horizontal plane of the bus and towards the front of the bus;

3.8.2.4.1.2 675 daN \pm 20 daN in the horizontal plane of the bus and towards the front of the bus on the lap portion of the belt and 675daN \pm 20daN in the horizontal plane of the bus and towards the front of the bus on the torso portion of the belt in the case of 3-point belt;

3.8.2.4.1.3 1,715 daN \pm 20 daN in an angle of $45^\circ \pm 10^\circ$ to the horizontal plane of the bus and towards the front of the bus on the wheelchair restraint system;

- 3.8.2.4.1.4 The forces shall be applied simultaneously.
- 3.8.2.4.2 **For Category M3:**
- 3.8.2.4.2.1 740 daN \pm 20 daN in the case of a lap belt. The force shall be applied on the wheelchair user restraint system in the horizontal plane of the bus and towards the front of the bus if the restraint system is not attached to the floor of the bus. If the restraint system is attached to the floor, the force shall be applied in an angle $45^\circ \pm 10^\circ$ to the horizontal plane of the bus and towards the front of the bus;
- 3.8.2.4.2.2 450 daN \pm 20 daN in the horizontal plane of the bus and towards the front of the bus on the lap portion of the belt and 450 daN \pm 20 daN in the horizontal plane of the bus and towards the front of the bus on the torso portion of the belt in the case of 3-point belt;
- 3.8.2.4.2.3 1,130 daN \pm 20 daN in an angle of $45^\circ \pm 10^\circ$ to the horizontal plane of the bus and towards the front of the bus on the wheelchair restraint system;
- 3.8.2.4.2.4 The forces shall be applied simultaneously.
- 3.8.2.5 In forward direction in the case of a combined wheelchair and wheelchair user restraint system.
- 3.8.2.5.1 **For Category M2;**
- 3.8.2.5.1.1 1,110 daN \pm 20 daN in an angle of $45^\circ \pm 10^\circ$ to the horizontal plane of the bus and towards the front of the bus on the wheelchair user restraint system in the case of a lap belt;
- 3.8.2.5.1.2 675 daN \pm 20 daN in an angle of $45^\circ \pm 10^\circ$ to the horizontal plane of the bus and towards the front of the bus on the lap portion of the belt and 675 daN \pm 20 daN in the horizontal plane of the bus and towards the front of the bus on the torso portion of the belt in the case of 3-point belt;
- 3.8.2.5.1.3 1,715 daN \pm 20 daN in an angle of $45^\circ \pm 10^\circ$ to the horizontal plane of the bus and towards the front of the bus on the wheelchair restraint system;
- 3.8.2.5.1.4 The forces shall be applied simultaneously.
- 3.8.2.5.2 For Category M3:
- 3.8.2.5.2.1 740 daN \pm 20 daN in an angle of $45^\circ \pm 10^\circ$ to the horizontal plane of the bus and towards the front of the bus on the wheelchair user restraint system in the case of a lap belt;
- 3.8.2.5.2.2 450 daN \pm 20 daN in an angle of $45^\circ \pm 10^\circ$ to the horizontal plane of the bus and towards the front of the bus on the lap portion of the belt and 450 daN \pm 20 daN in the horizontal plane of the bus and towards the front of the bus on the torso portion of the belt in the case of 3-point belt;
- 3.8.2.5.2.3 1,130 daN \pm 20 daN in an angle of $45^\circ \pm 10^\circ$ to the horizontal plane of the bus and towards the front of the bus on the wheelchair restraint system;
- 3.8.2.5.2.4 The forces shall be applied simultaneously.
- 3.8.2.6 In rearward direction:
- 3.8.2.6.1 810 daN \pm 20 daN in an angle of $45^\circ \pm 10^\circ$ to the horizontal plane of the

bus and towards the rear of the bus on the wheelchair restraint system.

- 3.8.2.7 In every case the forces shall be applied to the wheelchair user restraint system by means of a traction device appropriate to the belt type as specified in IS 15139-2002;.
- 3.8.3 Forward-facing Wheelchair – Hybrid Test Requirements
- 3.8.3.1 A wheelchair space shall be fitted with a wheelchair restraint system suitable for general wheelchair application and shall allow the carriage of a wheelchair and a wheelchair user facing the front of the bus;
- 3.8.3.2 A wheelchair space shall be fitted with a wheelchair user restraint system which shall comprise of a minimum of two anchorage points and a pelvic restraint (lap belt) designed and constructed of components intended to perform in a similar manner to those of a seat belt conforming to IS 15140-2003;
- 3.8.3.3 Any restraint system fitted to a wheelchair space shall be capable of being easily released in the case of an emergency;
- 3.8.3.4 Any wheelchair restraint system shall either:
- 3.8.3.4.1 Meet the dynamic test requirements described in Paragraph 3.8.3.8. and be securely attached to bus anchorages meeting the static test requirements in Paragraph 3.8.3.6. below; or
- 3.8.3.4.2 Be securely attached to bus anchorages such that the combination of restraint and anchorages meets the requirements of Paragraph 3.8.3.8.
- 3.8.3.5 Any wheelchair user restraint shall either:
- 3.8.3.5.1 Meet the dynamic test requirements described in Paragraph 3.8.3.9. and be securely attached to bus anchorages meeting the static test requirements in Paragraph 3.8.3.6. below; or
- 3.8.3.5.2 Be securely attached to bus anchorages such that the combination of restraint and anchorages meets the dynamic test requirements described in Paragraph 3.8.3.9. when attached to anchorages set up as described in Paragraph 3.8.3.6.7.
- 3.8.3.6 A static test shall be carried out on the anchorage points for both the wheelchair restraint system and the wheelchair user restraint in accordance with the following requirements:
- 3.8.3.6.1 The forces specified in Paragraph 3.8.3.7. below shall be applied by means of a device reproducing the geometry of the wheelchair restraint system;
- 3.8.3.6.2 The forces specified in Paragraph 3.8.3.7.3. below shall be applied by means of a device reproducing the geometry of the wheelchair user restraint and by means of a traction device specified in IS 15139-2002;.
- 3.8.3.6.3 The forces in Paragraph 3.8.3.6.1. above and Paragraph 3.8.3.6.2. shall be applied simultaneously in the forward direction and at an angle of $10^{\circ} \pm 5^{\circ}$ above the horizontal plane;
- 3.8.3.6.4 The forces in Paragraph 3.8.3.6.1. above shall be applied in the rearward

- direction and at an angle of $10^{\circ} \pm 5^{\circ}$ above the horizontal plane;
- 3.8.3.6.5 The forces shall be applied as rapidly as possible through the central vertical axis of the wheelchair space; and
 - 3.8.3.6.6 The force shall be maintained for a period of not less than 0.2s.
 - 3.8.3.6.7 The test shall be carried out on a representative section of the bus structure together with any fitting provided in the bus which is likely to contribute to the strength or rigidity of the structure.
 - 3.8.3.7 The forces specified in Paragraph 3.8.3.6. above are:
 - 3.8.3.7.1 In the case of anchorages provided for a wheelchair restraint system fitted to a Category M2 bus:
 - 3.8.3.7.1.1 1,110 daN \pm 20 daN applied in the longitudinal plane of the bus and towards the front of the bus at a height of not less than 200mm and not more than 300 mm measured vertically from the floor of the wheelchair space, and
 - 3.8.3.7.1.2 550 daN \pm 20 daN applied in the longitudinal plane of the bus and towards the rear of the bus at a height of not less than 200 mm and not more than 300mm measured vertically from the floor of the wheelchair space;
 - 3.8.3.7.2 In the case of anchorages provided for a wheelchair restraint system fitted to a Category M3 bus.
 - 3.8.3.7.2.1 740 daN \pm 20 daN applied in the longitudinal plane of the bus and towards the front of the bus at a height of not less than 200 mm and not more than 300mm measured vertically from the floor of the wheelchair space, and
 - 3.8.3.7.2 370 daN \pm 20 daN applied in the longitudinal plane of the bus and towards the rear of the bus at a height of not less than 200 mm and not more than 300 mm measured vertically from the floor of the wheelchair space;
 - 3.8.3.7.3 In the case of anchorages provided for a wheelchair user restraint system the forces shall be in accordance with the requirements of IS 15139-2002; The forces shall be applied by means of a traction device as appropriate to the belt type as specified in IS 15139-2002;
 - 3.8.3.8 A wheelchair restraint system shall be subject to a dynamic test carried out in accordance with the following requirements:
 - 3.8.3.8.1 A representative wheelchair test trolley of mass 85 kg shall, from a speed of between 48 km/h to 50 km/h to rest, be subject to a deceleration-time pulse:
 - 3.8.3.8.1.1 Exceeding 20 g in the forward direction for a cumulative period of at least 0.015 s;
 - 3.8.3.8.1.2 Exceeding 15 g in the forward direction for a cumulative period of at least 0.04 s;
 - 3.8.3.8.1.3 Exceeding a duration of 0.075 s;

- 3.8.3.8.1.4 Not exceeding 28 g and for not more than 0.08 s;
- 3.8.3.8.1.5 Not exceeding a duration of more than 0.12 s, and
- 3.8.3.8.2 A representative wheelchair test trolley of mass 85 kg shall, from a speed of between 48 km/h to 50 km/h to rest, be subject to a deceleration-time pulse:
 - 3.8.3.8.2.1 Exceeding 5 g in the rearward direction for a cumulative period of at least 0.015 s;
 - 3.8.3.8.2.2 Not exceeding 8g in the rearward direction and for not more than 0.02 s;
- 3.8.3.8.3 The test in Paragraph 3.8.3.8.2. above shall not apply if the same restraints are used for the forward and rearward direction or if an equivalent test has been conducted;
- 3.8.3.8.4 For the above test, the wheelchair restraint system shall be attached to either:
 - 3.8.3.8.4.1 Anchorages fixed to the test rig which represents the geometry of the anchorages in a bus for which the restraint system is intended, or
 - 3.8.3.8.4.2 Anchorages forming part of a representative section of the bus for which the restraint system is intended, set up as described in Paragraph 3.8.3.6.7. above.
- 3.8.3.9 A wheelchair user restraint shall comply with the test requirements specified in IS 15140-2003; or an equivalent test to the deceleration-time pulse in Paragraph 3.8.3.8.1. above. A seat belt approved to IS 15140-2003; and so marked shall be deemed to comply.
- 3.8.3.10 A test in Paragraph 3.8.3.6., 3.8.3.8. or 3.8.3.9. above shall be deemed to have failed unless the following requirements are met:
 - 3.8.3.10.1 No part of the system shall have failed, or shall have become detached from its anchorage or from the bus during the test;
 - 3.8.3.10.2 Mechanisms to release the wheelchair and user shall be capable of release after completion of the test;
 - 3.8.3.10.3 In the test in Paragraph 3.8.3.8. above the wheelchair shall not move more than 200mm in the longitudinal plane of the bus during the test;
 - 3.8.3.10.4 No part of the system shall be deformed to such an extent after completion of the test that, because of sharp edges or other protrusions, the part is capable of causing injury.
- 3.8.3.11 Its operating instructions shall be clearly displayed adjacent to it.
- 3.8.4 Rearward-facing Wheelchair – Static Test Requirements (To be discussed in panel)
 - 3.8.4.1 Buses not required to have occupant restraint systems fitted may, as an alternative to the provisions of Paragraph 3.8.2 or 3.8.3. above, be provided with a wheelchair space designed for the wheelchair user to travel unrestrained with the wheelchair facing rearwards against a support or

backrest, in accordance with the following provisions:

- 3.8.4.1.1 One of the longitudinal sides of the space for a wheelchair shall rest against a side or wall of the bus or a partition;
- 3.8.4.1.2 A support or backrest perpendicular to the longitudinal axis of the bus shall be provided in the forward end of the wheelchair space;
- 3.8.4.1.3 The support or backrest shall be designed for the wheels or the back of the wheelchair to rest against the support or backrest in order to avoid the wheelchair from tipping over and shall comply with the provisions of Paragraph 3.8.5. below;
- 3.8.4.1.4 A handrail or handhold shall be fitted to the side or wall of the bus or a partition in such a way to allow the wheelchair user to grasp it easily. This handrail shall not extend over the vertical projection of the wheelchair space, except by not more than 90mm and only at a height not less than 850mm above the floor of the wheelchair space;
- 3.8.4.1.5 A retractable handrail or any equivalent rigid device shall be fitted on the opposite side of the wheelchair space in order to restrict any lateral shift of the wheelchair and to allow the wheelchair user to grasp it easily;
- 3.8.4.1.6 A sign shall be fixed adjacent to the wheelchair area with the following text:

"This space is reserved for a wheelchair. The wheelchair shall be placed facing rearwards resting against the support or backrest with the brakes on"

The provisions of Paragraph 3.7.4.1 apply to any textual markings used.

3.8.5 **Backrest and Support Requirements**

- 3.8.5.1 A backrest fitted to a wheelchair space in accordance with Paragraph 3.8.4. shall be fitted perpendicular to the longitudinal axis of the bus and shall be capable of bearing a load of 250 ± 20 daN applied to the centre of the padded surface of the backrest, at a height of not less than 600mm and of not more than 800mm measured vertically from the floor of the wheelchair space, for a minimum of 1.5s by means of a block 200mm X 200mm in the horizontal plane of the bus towards the front of the bus. The backrest shall not deflect more than 100mm or suffer permanent deformation or damage.
- 3.8.5.2 A support fitted to a wheelchair space in accordance with Paragraph 3.8.4. shall be fitted perpendicular to the longitudinal axis of the bus and shall be capable of withstanding a force of $250\text{daN} \pm 20\text{daN}$ applied to the centre of the support, for a minimum of 1.5s in the horizontal plane of the bus towards the front of the bus in the middle of the support. The support shall not deflect more than 100mm or suffer permanent deformation or damage.
- 3.8.6 Example of a backrest meeting the requirements of Paragraph 3.8.4.1.3. above (See Fig.10 to this Annexure).

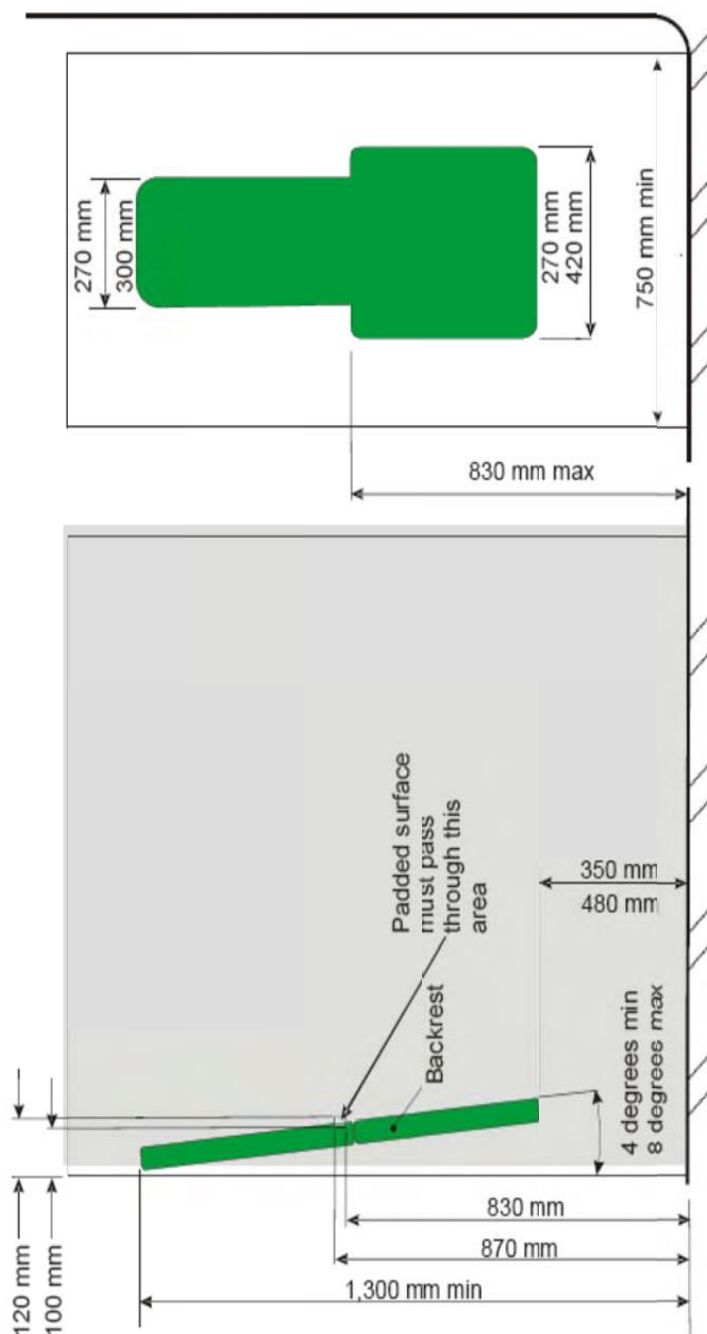

Figure 10

Example of a Backrest for a Rearward-facing Wheelchair

- 3.8.6.1 The bottom edge of a backrest shall be at a height of not less than 350mm and of not more than 480mm measured vertically from the floor of the wheelchair space.
- 3.8.6.2 The top edge of a backrest shall be at a height of not less than 1,300mm measured vertically from the floor of the wheelchair space.
- 3.8.6.3 A backrest shall have a width of:
 - 3.8.6.3.1 Not less than 270mm and of not more than 420mm up to a height of 830mm measured vertically from the floor of the wheelchair space, and

- 3.8.6.3.2 Not less than 270mm and of not more than 300mm at heights exceeding 830mm measured vertically from the floor of the wheelchair space.
- 3.8.6.4 A backrest shall be fitted at an angle of not less than 4 degree and of not more than 8 degree to the vertical with the bottom edge of the backrest positioned closer to the rear of the bus than the top edge.
- 3.8.6.5 The padded surface of a backrest shall form a single and continuous plane.
- 3.8.6.6 The padded surface of a backrest shall pass through any point on an imaginary vertical plane situated to the rear of the front end of the wheelchair space and situated not less than 100mm and not more than 120mm from the front end of the wheelchair space measured horizontally and not less than 830mm and not more than 870mm from the floor of the wheelchair space measured vertically.
- 3.9 **Door Controls**
- 3.9.1 If a door referred to in Paragraph 3.6 is fitted with opening controls for use under normal circumstances, these controls shall:
- 3.9.1.1 In the case of exterior controls, be on or adjacent to that door at a height between 850mm and 1,300mm from the ground and be not more than 900mm from the door, and
- 3.9.1.2 In the case of interior controls in buses of Type I, II and III, be on or adjacent to that door at a height of between 850mm and 1,300mm from the upper surface of the floor nearest the control and be not more than 900mm in any direction from the door aperture.
- 3.10 **Provisions for the Accommodation of Unfolded Prams and Pushchairs**
- 3.10.1 (Reserved)
- 3.10.2 The dimensions of the unfolded pram or pushchair area shall not be less than 750mm wide and 1,300mm long. Its longitudinal plane shall be parallel to the longitudinal plane of the bus and the floor surface shall be slip resistant.
- 3.10.3 Accessibility to prams and pushchairs areas shall be provided in accordance with the following provisions:
- 3.10.3.1 It shall be possible for an unfolded pram or pushchair to be moved freely and easily from the outside of the bus through at least one of the service doors into the special area(s)
- 3.10.3.1.1 By "moving freely and easily", it is meant that:
- (a) There is sufficient space available for the pram or pushchair to be manoeuvred;
- (b) There are no steps, gaps or stanchions which could be an obstacle to the free movement of the pram or pushchair.
- 3.10.4 The area shall be fitted with the pictogram (See Fig.11 to this Annexure).



For each Prams and Pushchairs

Colour: blue basis with white symbol

Size: at least 130mm diameter

Reference for the design principles of safety symbols: ISO 3864-1:2011

Figure 11

Pictogram for Pram and pushchair Area

- 3.10.4.1 The same pictogram shall be placed both on the front nearside of the bus and adjacent to the service door that gives access to the pram or pushchair area.
- 3.10.5 The following requirements shall apply to the stability of the unfolded pram or pushchair:
- 3.10.5.1 One of the longitudinal sides of the space for a pram or pushchair shall rest against a side or wall of the bus or a partition;
- 3.10.5.2 A support or backrest perpendicular to the longitudinal axis of the bus shall be provided in the forward end of the pram or pushchair space;
- 3.10.2.3 The support or backrest shall be designed to avoid the pram or pushchair from tipping over and shall comply with the provisions of Paragraph 3.8.5. above;
- 3.10.2.4 A handrail or handhold shall be fitted to the side or wall of the bus or a partition in such a way to allow the accompanying person to grasp it easily. This handrail shall not extend over the vertical projection of the pram or pushchair space, except by not more than 90mm and only at a height not less than 850mm above the floor of the pram or pushchair space;
- 3.10.5.5 A retractable handrail or any equivalent rigid device shall be fitted on the opposite side of the pram or pushchair space in order to restrict any lateral shift of the pram or pushchair.
- 3.10.6 The area shall be provided with a specific control, e.g. a push-button, to enable the passenger with an unfolded pram or pushchair to request that the bus be stopped at the next bus stop. The general requirements of Paragraph 3.10.6.1 shall apply.

- 3.10.6.1 On buses of Type I, II, a means shall be provided to enable passengers to signal that the driver should stop the bus. The controls for all such communication devices shall be capable of being operated with the palm of the hand. There shall be appropriate communication devices distributed adequately and evenly throughout the bus and no more than 1,500mm from the floor, this does not exclude the possibility of installing higher additional communication devices. Controls shall contrast visually with their immediate surroundings. Activation of the control shall also be indicated to the passengers by means of one or more illuminated signs. The sign shall display the words "bus stopping" or equivalent, and/or a suitable pictogram and shall remain illuminated until the service door(s) open. Articulated buses shall have such signs in each rigid section of the bus. The provisions of Paragraph 3.7.4.1 apply to any textual markings used.
- 3.10.7 The control shall be fitted with the pictogram described (See Fig.12 to this Annexure).. The dimensions of the pictogram may be reduced as needed.
- 3.10.8 The area to accommodate the unfolded pram or pushchair may adjoin the area for the wheelchair and be in its extension. Intrusions of stanchions to provide handholds for standing passengers may be permitted provided the requirement of Paragraph 3.10.3. of this Annexure is met.
- 3.10.9 Additional wheelchair areas may be combined with the area for the accommodation of an unfolded pram or pushchair provided the relevant requirements are met. In such a case, the area shall have signs fixed on or adjacent to them with the following text, equivalent text or pictogram:
- "Please give up this space for a wheelchair user".
- 3.11 **Provisions for Boarding Devices**
- 3.11.1 General requirements:
- 3.11.1.1 The controls actuating the boarding devices shall be clearly marked as such. The extended or lowered position of the boarding device shall be indicated by a tell-tale to the driver.
- 3.11.1.2 In the event of the failure of a safety device, lifts, ramps and kneeling systems shall be incapable of operation, unless they can be safely operated by manual effort. The type and location of the emergency operating mechanism shall be clearly marked. In the event of power failure, lifts and ramps shall be capable of manual operation.
- 3.11.1.3 Access to one of the service or emergency doors on the bus may be obstructed by a boarding device providing the following two conditions are satisfied from both inside and outside the bus.
- 3.11.1.3.1 The boarding device does not obstruct the handle or other device for opening the door.
- 3.11.1.3.2 The boarding device can be readily moved to leave the doorway clear for use in an emergency.

3.11.2 **Kneeling System**

- 3.11.2.1 A switch shall be required to enable operation of the kneeling system.
- 3.11.2.2 Any control which initiates the lowering or raising of any part or the whole of the bodywork relative to the road surface shall be clearly identified and be under the direct control of the driver.
- 3.11.2.3 The lowering process shall be capable of being stopped and immediately reversed by a control both within the reach of the driver, whilst seated in the cab, and also adjacent to any other operating controls provided for the operation of the kneeling system.
- 3.11.2.4 Any kneeling system that is fitted to a bus shall not allow the bus to be driven at a speed of more than 5km/h when the bus is lower than the normal height of travel.

3.11.3 **Lift**

3.11.3.1 **General Provisions**

- 3.11.3.1.1 Lifts shall only be capable of operation when the bus is at standstill. Any movement of the platform shall be prevented unless a device preventing the wheelchair from rolling off has been activated or has automatically come into operation.
- 3.11.3.1.2 The lift platform shall not be less than 800mm wide, and not less than 1,200mm long and shall be capable of operating when carrying a mass of at least 300kg.
- 3.11.3.2 Additional technical requirements for power-operated lifts
 - 3.11.3.2.1 The operating control shall be designed in such a way that, if released, it automatically returns to the off position. As it does so the movement of the lift shall immediately be stopped and it shall be possible to initiate a movement in either direction.
 - 3.11.3.2.2 A safety device (e.g. reversing mechanism) shall protect areas not visible to the operator, where the movement of the lift might trap or crush objects.
 - 3.11.3.2.3 In the event of one of these safety devices coming into operation, the movement of the lift shall immediately be stopped and movement in the opposite direction initiated.
- 3.11.3.3 Operation of power operated lifts
 - 3.11.3.3.1 Where the lift is at a service door situated within the direct field of vision of the driver of the bus, the lift may be operated by the driver when in the driver's seat.
 - 3.11.3.3.2 In all others cases, the controls shall be adjacent to the lift. They shall be capable of being activated and deactivated only by the driver from his seat.
- 3.11.3.4 Manually operated lift

- 3.11.3.4.1 The lift shall be designed for operation by controls adjacent to the lift.
- 3.11.3.4.2 The lift shall be so designed that excessive forces are not required to operate it.
- 3.11.4 **Ramp**
- 3.11.4.1 **General Provisions**
- 3.11.4.1.1 The ramp shall only be capable of operation when the bus is at standstill.
- 3.11.4.1.2 Edges on the outside shall be rounded to a radius of no less than 2.5mm. Corners on the outside shall be rounded to a radius of not less than 5mm.
- 3.11.4.1.3 The useable surface of a ramp shall be at least 800mm wide. The slope of the ramp, when extended or folded out on to a kerb of 150mm in height, should not exceed 12%. The slope of the ramp, when extended or folded out to the ground, should not exceed 36%. A kneeling system may be used to achieve this test.
- 3.11.4.1.4 Any ramp which when ready for use exceeds 1,200mm in length shall be fitted with a device to prevent the wheelchair rolling off the sides.
- 3.11.4.1.5 Any ramp shall be capable of operating safely with a load of 300kg.
- 3.11.4.1.6 The outer edge of ramp surfaces available for use by a wheelchair shall be clearly marked with a band of colour 45mm to 55mm in width which contrasts visually with the remainder of the ramp surface. The band of colour shall extend along the outermost edge and along both edges parallel to the direction of travel of the wheelchair.
- Marking of any trip hazard or where part of the ramp surface also forms part of the step is permissible.
- 3.11.4.1.7 A portable ramp shall be secure when in its position for use. A portable ramp shall be provided with a suitable position where it can be safely stowed and where it is readily available for use.
- 3.11.4.2 **Modes of Operation**
- 3.11.4.2.1 Deployment and stowage of the ramp may be either manually or power-operated.
- 3.11.4.3 **Additional Technical Requirements for Power-operated Ramps**
- 3.11.4.3.1 Deployment and stowage of the ramp shall be indicated by flashing yellow lights and an audible signal.
- 3.11.4.3.2 Deployment and stowage of the ramp that may create a risk of injury shall be protected by a safety device(s).
- 3.11.4.3.3 These safety devices shall stop the movement of the ramp when the ramp is subject to a reactive force not exceeding 150N. The peak force may be higher than 150N for a short time provided that it does not exceed 300N. The reactive force may be measured by any method to the satisfaction of

the Type Approval Authority. Guidelines for measuring the reactive forces are given in ANNEXURE VI to this Standard.

- 3.11.4.3.4 The horizontal movement of a ramp shall be interrupted when a mass of 15kg is placed upon it.
- 3.11.4.4 Operation of power-operated ramps
 - 3.11.4.4.1 Where the driver has an adequate view of the ramp sufficient to monitor its deployment and use, to ensure the safety of passengers, the ramp may be operated by the driver when in the driver's seat. This requirement may be met by a suitable indirect vision device(s).
 - 3.11.4.4.2 In all others cases, the controls shall be adjacent to the ramp. They shall be capable of being activated and deactivated only by the driver from his seat.
- 3.11.4.5 Operation of manually-operated ramp
 - 3.11.4.5.1 The ramp shall be so designed that excessive forces are not required to operate the ramp.

ANNEXURE VI

(See ANNEXURE V, Paragraph 3.11.4.3.3.)

THE REACTIVE FORCES OF POWER-OPERATED RAMPS**1.0 GENERAL**

The operation of a power-operated ramp is dynamic processes. When a moving ramp hits an obstacle, the result is a dynamic reaction force, the history of which (in time) depends on several factors (e.g. mass of the door or ramp, acceleration, dimensions).

2.0 DEFINITIONS

2.1 Closing or reactive force $F(t)$ is a time function, measured at the outer edge of the ramp (see Paragraph 3.2. below).

2.2 Peak force F_S is the maximum value of the closing or reactive force.

2.3 Effective force F_E is the average value of the closing or reactive force related to the pulse duration:

$$F_E = \frac{1}{T} \int_{t_1}^{t_2} F(t) dt$$

2.3.1 Pulse duration T is the time between the t_1 and t_2 :

$$T = t_2 - t_1$$

Where,

t_1 = threshold of sensitivity, where the closing or reactive force exceeds 50N.

t_2 = fade-away threshold, where the closing or reactive force becomes less than 50N.

2.3.2 The relation between the above parameters is shown in Figure 1 below (as an example):

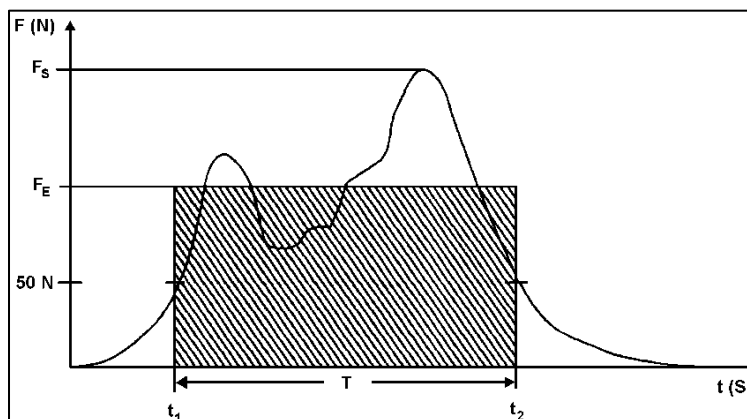

Figure 1

- 2.3.3** Clamping or mean reactive force F_C is the arithmetical mean value of the effective forces, measured at the same measuring point subsequently more times:

$$F_c = \frac{\sum_{i=1}^{i=n} (F_E)_i}{n}$$

3.0 MEASUREMENTS

3.1 Conditions of measurement:

- 3.1.1 Temperature range: 10° - 30°C

- 3.1.2 The bus shall be standing on a horizontal surface. In the case of ramp measurements, this surface shall be fitted with a rigidly mounted block or other similar device having a face against which the ramp can react.

3.2 Measurements points shall be:

- 3.2.1 In the case of ramps:

- 3.2.1.1 At the outer edge of the ramp situated perpendicularly to its direction of movement: one in the middle of the ramp;

one 100mm inboard from each of the edges parallel to the direction of travel of the ramp.

- 3.3 At least three measurements shall be taken at each of the measuring points to determine the clamping or mean reactive force according to Paragraph 2.6. above.

- 3.4 The signal of the closing or reactive force shall be recorded by means of a low-pass filter with a limiting frequency of 100Hz. Both the threshold of sensitivity and the fade-away threshold to limit the pulse duration shall be set at 50N.

- 3.5 The deviation of the reading from the rated value shall not be more than $\pm 3\%$.

4.0 MEASURING DEVICE

4.1 The measuring device shall consist of two parts: one handle and one measuring part which is a load cell (see Figure 2).

4.2 The load cell shall have the following characteristics:

4.2.1 It shall consist of two sliding housings with the outer dimension of 100mm in diameter and 115mm in width. Inside the load cell a compression spring shall be fitted between the two housings such that the load cell can be pressed together if an appropriate force is applied.

4.2.2 The stiffness of the load cell shall be 10 ± 0.2 N/mm. The maximum spring deflection shall be limited to 30mm so that a maximum peak force of 300N is achieved.

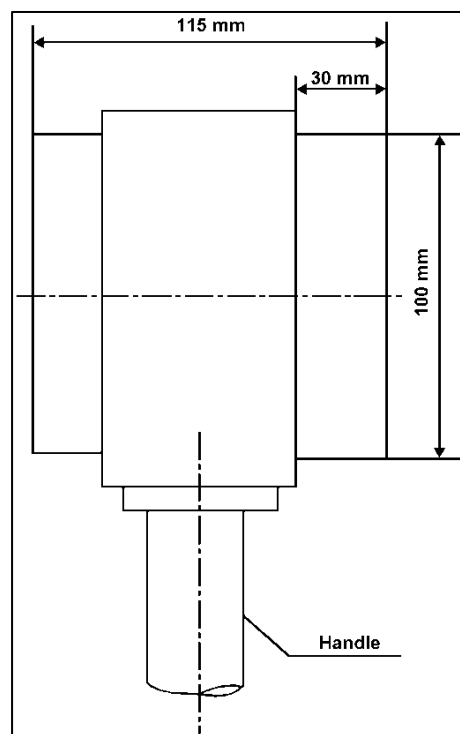

Figure 2

ANNEXURE VII
COMPOSITION OF AISC PANEL *

Name	Organization
Convener	
Mr. D. P. Saste	MoRT&H
Members	Representing
Mr. A. V. Mannikar / Mr. N. V. Karanth / Mr. A. A. Badusha / Mr. Mahesh Patwardhan / Mr. Pradeep Jawale/ Mr. K. B. Patil	The Automotive Research Association of India (ARAI)
Mr. S. N. Dhole/ Mr. S. Hasan Ali/ Ms. Shubhangi Dalvi	CIRT
Ms. Vijayanta Ahuja	ICAT
Shri P. K. Banerjee	SIAM
Mr. S. Ravishankar / Mr. D. Balakrishnan / Mr. V. Faustino	Ashok Leyland Technical Centre (SIAM)
Mr. Girish S Kodolikor / Mr. L. B. Patil / Mr. Suraj R. Supekar	Force Motors Ltd. (SIAM)
Mr. C. Dinesh Kumar	Daimler India Commercial Veh. Pvt. Ltd. (SIAM)
Mr. Helmut karrasch	Daimler India Commercial Veh. Pvt. Ltd. (SIAM)
Shri Sakthivelan S	Mahindra and Mahindra Ltd. (SIAM)
Mr. V. G. Kulkarni / Mr. Vinesh M	Mahindra and Mahindra Ltd. (SIAM)
Mr. Deepak Vashista/ Mr. Mohit Gupta/ Mr. Sachin Bhat	SML Isuzu Ltd. (SIAM)
Mr. K. L. Shon / Mr. Vijayaraj / Mr. Babian Fernando G	Scania CV India Pvt. Ltd.(SIAM)
Mr. P. S. Gowrishankar/ Mr. S. S. Bhole	Tata Motors Ltd. (SIAM)
Mr. Pramodkumar Hugar	Volvo Buses (SIAM)
Mr. Dilip P. Desai	ACGL
Mr. Sridhar Kalmadi	Corona Bus

ANNEXURE VIII
COMMITTEE COMPOSITION – AISC

Chairperson	
Mrs. Rashmi Urdhwareshe	Director The Automotive Research Association of India, Pune
Members	Representing
Shri Priyank Bharti	Ministry of Road Transport and Highways (Dept. of Road Transport and Highways), New Delhi
Representative from	Ministry of Heavy Industries and Public Enterprises (Department of Heavy Industry), New Delhi
Shri S. M. Ahuja	Office of the Development Commissioner, MSME, Ministry of Micro, Small and Medium Enterprises, New Delhi
Shri Shrikant R. Marathe	Former Chairman, AISC
Shri R.R. Singh	Bureau of Indian Standards, New Delhi
Director	Central Institute of Road Transport, Pune
Director	Global Automotive Research Centre
Director	International Centre for Automotive Technology, Manesar
Director	Indian Institute of Petroleum, Dehra Dun
Director	Indian Rubber Manufacturers Research Association
Director	Vehicles Research and Development Establishment, Ahmednagar
Representatives from	Society of Indian Automobile Manufacturers
Shri T. R. Kesavan	Tractor Manufacturers Association, New Delhi
Shri Uday Harite	Automotive Components Manufacturers Association of India, New Delhi