

Draft AIS-034 (Part 2) (Rev.3) :2022/D1
June 2023

DRAFT-D1

AUTOMOTIVE INDUSTRY STANDARD

**Provisions concerning the Approval of
Gas-discharge Light Sources for use in
Approved Lamps of Power-driven
Vehicles**

(Revision 3)

Date of hosting on website: 13th June 2023

Last Date for comments: 12th July 2023

INTRODUCTION

0. The Government of India felt the need for a permanent agency to expedite the publication of standards and development of test facilities in parallel when the work on the preparation of the standards is going on, as the development of improved safety critical parts can be undertaken only after the publication of the standard and commissioning of test facilities. To this end, the erstwhile Ministry of Surface Transport (MOST) has constituted a permanent Automotive Industry Standards Committee (AISC) vide order No. RT-11028/11/97-MVL dated September 15, 1997. The standards prepared by AISC will be approved by the permanent CMVR Technical Standing Committee (CTSC). After approval, the Automotive Research Association of India, (ARAI), Pune, being the Secretariat of the AIS Committee, has published this standard. For better dissemination of this information ARAI may publish this document on their Web site.
- 0.1 Accordingly, AIS-034 covering mandatory requirements regarding performance of filament lamps and gas discharge light source for use in lighting & light signalling devices for automotive vehicles has been published in 2004 and has been implemented thereafter in 2005.
- 0.2 With technological developments in filament lamps and gas discharge light sources, AIS-034 was taken up for revision and now is prepared in two parts.

This part covers Automobile gas discharge light sources approval of gas discharge light sources for use in approved Gas discharge lamp units of power driven vehicles
- 0.3 This part is based on ECE regulations R99 Rev 3 amendment 5 (Supplement 14 to the original version of the Regulation – Date of entry into force: 28th May 2019)
- 0.4 While preparing this standard attempts have been made to align with the above ECE regulation. However, certain changes were necessary in the Indian context.

Draft AIS-034 (Part 2) (Rev.3) :2022/D1
June 2023

0.5 The following standards contain provisions, which through reference in this text constitute provisions of the standard.

AIS-037	Procedure for Type Approval and Establishing Conformity of Production for Safety Critical Components.
AIS-010 (Part 5) (Rev.2):2021	Requirements of Chromaticity Co-ordinates of colour of light emitted from Lighting and Light Signalling Devices
AIS-008 Rev.3:2022	Installation Requirements of Lighting and Light - Signalling Devices for Motor Vehicle having more than Three Wheels including Quadricycles, Trailer and Semi-Trailer excluding Agricultural Tractors
IEC 60051	Direct Acting Indicating Analogue Electrical Measuring Instruments and their Accessories
IEC Publication 60410:	Sampling Plans and Procedures for Inspection by Attributes
IEC Publication 60061,third edition,	Lamp Caps and Holders together with Gauges for the Control of Interchangeability and Safety - Part 1: Lamp Caps

Commented [HMCL1]: As discussed during 3rd panel meeting, for colour definition AIS-008 Rev.3 shall be referred through all lighting standards and hence this reference of AIS-010 Part 5 has been deleted

Commented [HMCL2]: As discussed during 3rd panel meeting, for colour definition AIS-008 Rev.3 shall be referred through all lighting standards and hence this reference of AIS-008 Rev.3 has been added

0.6 AISC panel and AIS Committee responsible for preparation of this standard are given in Annex J and Annex K respectively.

Draft AIS-034 (Part 2) (Rev.3) :2022/D1
June 2023

**Provisions concerning the Approval of Gas-discharge Light
Sources for use in Approved Lamps of Power-driven Vehicles**

Para. No.	Contents	Page No.
1.	Scope	1
2.	Administrative provisions	1
2.1	Definitions	1
2.2	Application for approval	1
2.3	Inscriptions	2
2.4	Approval	2
3.	Technical requirements	3
3.1	Definitions	3
3.2	General specifications	3
3.3	Manufacture	4
3.4	Tests	4
3.5	Position and dimensions of electrodes, arc and stripes	4
3.6	Starting, run-up and hot restrike characteristics	5
3.7	Electrical characteristics	6
3.8	Luminous flux	6
3.9	Colour	6
3.10	UV radiation	7
3.11	Standard gas-discharge light sources	8
4	Conformity of production	8
5.	Penalties for non-conformity of production	8
6.	Reserved	8
7.	Reserved	8
8.	Transitional provisions	8

Draft AIS-034 (Part 2) (Rev.3) :2022/D1
June 2023

9	Extension of type approval	9
10	Establishing compliance of E/e approved gas discharge light source to this standard	10
11	Amendments to ECE regulations after the level described in 0.3 of foreword	10
List of Annexes		
Annex A	Sheets for gas-discharge light sources	11
Annex B	Information to be submitted at the time of application for type approval	52
Annex C	Reserved.	53
Annex D	Method of measurement of electrical and photometric characteristics	53
Annex E	Optical set-up for the measurement of the position and form of the arc and of the position of the electrodes	55
Annex F	Minimum requirements for quality control procedures by the manufacturer	56
Annex G	Sampling and compliance levels for manufacturer's test records	58
Annex H	Minimum requirements for sampling by testing agency.	62

**CHECK LIST FOR PREPARING AUTOMOTIVE INDUSTRY
STANDARD**

**Provisions concerning the Approval of Gas-
discharge Light Sources for use in Approved
Lamps of Power-driven Vehicles**

SR. NO.	PARTICULARS	REMARKS
	Indicate details of the base reference standard. (e.g. ECE / EEC Directive/GTR etc.)	
1.	Add an explanatory note indicating differences between the above standard and the draft, if any.	
2.	Specify details of technical specifications to be submitted at the time of type approval relevant to the requirements of this standard covered.	
3.	Are the details of Worst Case Criteria covered?	
4.	Are the performance requirements covered?	
5.	Is there a need to specify dimensional requirements?	
6.	If yes, are they covered?	
7.	Is there a need to specify COP requirements? If yes, are they covered?	
8.	Is there a need to specify type approval and routine test separately, as in the case of some of the Indian Standards? If yes, are they covered?	
9.	If the standard is for a part/component or sub-system; i) AIS-037 or ISI marking scheme be implemented for this part? ii) Are there any requirements to be covered for this part when fitted on the vehicle?	

Draft AIS-034 (Part 2) (Rev.3) :2022/D1
June 2023

	If yes, has a separate standard been prepared?	
10.	If the standard is intended for replacing or revising an already notified standard, are transitory provisions for re-certification of already certified parts/vehicles by comparing the previous test result, certain additional test, etc. required? If yes, are they included?	
11.	Include details of any other international or foreign national standards which could be considered as alternate standard.	
12.	Are the details of accuracy and least counts of test equipment/meters required to be specified? If yes, have they been included?	
13.	What are the test equipment for establishing compliance?	
14.	If possible, identify such facilities available in India.	
15.	Are there any points on which special comments or information is to be invited from members? If yes, are they identified?	
16.	Does the scope of standard clearly identify vehicle categories?	
17.	Has the clarity of definitions been examined?	

**Provisions concerning the Approval of
Gas-discharge Light Sources for use in Approved
Gas-discharge Lamp units of Power-driven Vehicles**

1. SCOPE

This standard applies to gas-discharge light sources shown in Annex A to this standard and intended for use in approved lamps of power-driven vehicles.

2. ADMINISTRATIVE PROVISIONS

2.1. Definitions

2.1.1. The term "**category**" is used in this standard to describe different basic design of standardized gas-discharge light sources. Each category has a specific designation, as for example: "D2S".

2.1.2. Gas-discharge light sources of different "**types**"¹ are gas-discharge light sources within the same category which differ in such essential respects as:

2.1.2.1. Trade name or mark; that means:

(a) Gas-discharge light sources bearing the same trade name or mark but produced by different manufacturers are considered as being of different types.

(b) Gas-discharge light sources produced by the same manufacturer differing only by the trade name or mark may be considered to be of the same type.

2.1.2.2. Bulb and/or cap design, in so far as these differences affect the optical results;

2.2. Application for approval

2.2.1. Information to be submitted at the time of applying for type approval of the gas discharge light source shall be as given in Annex B.

2.2.2. Reserve

2.2.2.1. Reserved

2.2.2.2. Reserved

2.2.2.3. Three samples of each colour which has been applied for;

2.2.2.4. One sample of the ballast in case the ballast is not integrated with the light source.

2.2.3. In the case of a type of gas-discharge light source differing only by the trade name or mark from a type that has already been approved it shall be sufficient to submit:

2.2.3.1. A declaration by the manufacturer that the type submitted is identical (except in the trade name or mark) to and has been produced by the same manufacturer as, the type already approved, the latter being identified by its approval code;

2.2.3.2. Two samples bearing the new trade name or mark.

Draft AIS-034 (Part 2) (Rev.3) :2022/D1
June 2023

¹ A selective yellow bulb or an additional selective yellow outer bulb, solely intended to change the colour but not the other characteristics of a gas-discharge light source emitting white light, does not constitute a change of type of the gas-discharge light source.

2.2.4. The testing agency shall verify the existence of satisfactory arrangements for ensuring effective control of the conformity of production before type approval is granted.

2.3. **Inscriptions**

2.3.1. Gas-discharge light sources submitted for approval shall bear on the cap or bulb:

2.3.1.1. The trade name or mark of the device manufacturer;

2.3.1.2. The international designation of the relevant category;

2.3.1.3. The rated wattage; this need not to be indicated separately if it is part of the international designation of the relevant category;

2.3.1.4. A space of sufficient size to accommodate the approval mark.

2.3.2. The space mentioned in clause 2.3.1.4. above shall be indicated in the drawings accompanying the application for approval.

2.3.3. Other inscriptions than those covered by clause 2.3.1. above and clause 2.4.4. may be affixed on the cap.

2.3.4. In case the ballast is not integrated with the light source, the ballast used for the type approval of the light source shall be marked with type and trade mark identification and with the rated voltage and wattage, as indicated on the relevant gas-discharge light source sheet.

2.3.5. On the prototype for type approval, the markings may be provided by suitable temporary methods and need not necessary be obtained from the tools used for series production.

2.4. **Approval**

2.4.1. If all samples of a type of gas-discharge light source which are submitted in accordance with clause 2.2.2.3. or clause 2.2.3.2. above comply with the requirements of this standard when tested with the ballast according to clause 2.2.2.4. in case the ballast is not integrated with the light source, approval shall be granted.

2.4.2. An approval code shall be assigned as per AIS-037 to each type approved gas-discharge light source.

2.4.3. Reserved

2.4.4. To every gas-discharge light source conforming to a type approved under this standard there shall be affixed in the space referred to in clause 2.3.1.4. above, in addition to the inscriptions required under clause 2.3.1. above an approval mark

- 2.4.4.1. Reserved.
- 2.4.4.2. Reserved.
- 2.4.5. Reserved.
- 2.4.6. The marks and inscriptions specified in clause 2.3.1. and clause 2.4.3. above shall be clearly legible and be indelible.
- 2.4.7. Reserved.

3. TECHNICAL REQUIREMENTS

3.1. Definitions

- 3.1.1. **"Gas-discharge light source"**: light source in which the light is produced by a stabilized discharge arc.
- 3.1.2. **"Ballast"**: Specific electrical supply for the gas-discharge light source, optionally integrated with the light source.
- 3.1.3. **"Rated voltage"**: Input voltage marked on the ballast or on the light source in the case that the ballast is integrated with the light source.
- 3.1.4. **"Rated wattage"**: Wattage marked on the gas-discharge light source and ballast.
- 3.1.5. **"Test voltage"**: Voltage, at the input terminals of the ballast or at the terminals of the light source in the case that the ballast is integrated with the light source, for which the electrical and photometric characteristics of the gas-discharge light source are intended and are to be tested.
- 3.1.6. **"Objective value"**: Design value of an electrical or photometric characteristic. To be achieved, within the specified tolerances, when the gas-discharge light source is energized by the ballast, optionally integrated with the light source, and operated at test voltage.
- 3.1.7. **"Standard (etalon) gas-discharge light source"**: Special gas-discharge light source used for the testing of headlamps. It has reduced dimensional, electrical and photometric characteristics as specified on the relevant data sheet.
- 3.1.8. **"Reference axis"**: An axis defined with reference to the cap and to which certain dimensions of the gas-discharge light source are referred.
- 3.1.9. **"Reference plane"**: a plane defined with reference to the cap and to which certain dimensions of the gas-discharge light source are referred.

3.2. General specifications

- 3.2.1. Each sample submitted shall conform to the relevant specifications of this standard when tested, in the case the ballast is not integrated with the light source with the ballast according to clause 2.2.2.4. above.
- 3.2.2. Gas-discharge light sources shall be so designed as to be and to remain in good working order when in normal use. They shall moreover exhibit no fault in design or manufacture.
- 3.2.3. The discharge arc shall be the only element of the gas-discharge light source that generates and emits light when energized.

3.3. Manufacture

- 3.3.1. The bulb of the gas-discharge light source shall exhibit no scores or spots which might impair their efficiency and their optical performance.
- 3.3.2. In the case of a coloured (outer) bulb, after an operating period of 15 hours with the ballast or the light source with the ballast integrated at test voltage, the surface of the bulb shall be lightly wiped with a cotton cloth soaked in a mixture of 70 volume per cent of n-heptane and 30 volume per cent of toluol. After about five minutes, the surface shall be inspected visually. It shall not show any apparent changes.
- 3.3.3. Gas-discharge light sources shall be equipped with standard caps complying with the cap data sheets of IEC Publication 60061, as specified on the individual data sheets of Annex A.
- 3.3.4. The cap shall be strong and firmly secured to the bulb.
- 3.3.5. To ascertain whether gas-discharge light sources conform to the requirements of clause 3.3.3. to clause 3.3.4., above, a visual inspection, a dimension check and, where appropriate, a trial fitting shall be carried out.

3.4. Tests

- 3.4.1. Gas-discharge light sources shall be aged as indicated in Annex D.
- 3.4.2. All samples shall be tested with the ballast, according to clause 2.2.2.4 above, in case the ballast is not integrated with the light source.
- 3.4.3. Electrical measurements shall be carried out with instruments of at least class 0.2 (0.2 percent full scale accuracy).

3.5. Position and dimensions of electrodes, arc and stripes

- 3.5.1. The geometric position of the electrodes shall be as specified on the relevant data sheet. An example of a method of measuring arc and electrodes position is given in Annex E. Other methods may be used.

- 3.5.1.1. The position and dimensions of the light source electrodes shall be measured before the ageing period, the gas-discharge light source unlit and using optical methods through the glass envelope.
- 3.5.2. The shape and the displacement of the arc shall conform to the requirements as given on the relevant data sheet.
- 3.5.2.1. The measurement shall be made after ageing with the light source supplied by the ballast at test voltage or the light source with the ballast integrated at test voltage.
- 3.5.3. The position and dimension and transmission of the stripes shall comply with the requirements as given on the relevant data sheet.
- 3.5.3.1. The measurement shall be made after ageing with the light source supplied by the ballast at test voltage or the light source with the ballast integrated at test voltage.
- 3.6. **Starting, run-up and hot-restrike characteristics**
- 3.6.1. **Starting**
- When tested according to the conditions specified in Annex D, the gas-discharge light source shall start directly and remain alight.
- 3.6.2. **Run-up**
- 3.6.2.1. For gas-discharge light sources having an objective luminous flux which exceeds 2,000 lm:
- When measured according to the conditions specified in Annex D to this standard, the gas-discharge light source shall emit at least:
- After 1 second: 25 per cent of its objective luminous flux;
- After 4 seconds: 80 per cent of its objective luminous flux.
- The objective luminous flux as indicated on the relevant data sheet.
- 3.6.2.2. For gas-discharge light sources having an objective luminous flux which does not exceed 2000 lm and does not contain black stripes:
- When measured according to the conditions specified in Annex D, the gas-discharge light sources shall emit at least 800 lm after 1 second and at least 1,000 lm after 4 seconds.
- The objective luminous flux as indicated on the relevant data sheet.
- 3.6.2.3. For gas-discharge light sources having an objective luminous flux which does not exceed 2,000 lm but does contain black stripes:
- When measured according to the conditions specified in Annex D, the gas-discharge light sources shall emit at least 700 lm after 1 second and at least 900 lm after 4 seconds.
- The objective luminous flux as indicated on the relevant data sheet.

Draft AIS-034 (Part 2) (Rev.3) :2022/D1
June 2023

- 3.6.2.4. For gas-discharge light sources having more than one objective luminous flux, and at least one objective luminous flux does not exceed 2,000 lm:

When measured according to the conditions specified in Annex D, the gas-discharge light sources shall emit at least 800 lm after 1 second and at least 1,000 lm after 4 seconds.

The objective luminous flux as indicated on the relevant data sheet.

- 3.6.3. Hot-restrike

When tested according to the conditions specified in Annex D, the gas-discharge light source shall restart directly after being switched-off for a period as indicated on the data sheet. After one second the light source shall emit at least 80 per cent of its objective luminous flux.

- 3.7. **Electrical characteristics**

When measured according to the conditions specified in Annex D, the voltage and wattage of the light source shall be within the limits given on the relevant data sheet.

- 3.8. **Luminous flux**

When measured according to the conditions specified in Annex D, the luminous flux shall be within the limits given on the relevant data sheet. In the case where white and selective yellow is specified for the same type, the objective value applies to light sources emitting white light, whereas the luminous flux of the light source emitting selective yellow light shall be at least 68 per cent of the specified value.

- 3.9. **Colour**

- 3.9.1. The colour of the light emitted shall be white or selective yellow. Moreover the colorimetric characteristics, expressed in CIE chromaticity coordinates, shall lie within the boundaries given on the relevant data sheet.

- 3.9.2. The definitions of the colour of the light emitted, given in AIS-010 (Part 5) (Rev. 1) and its amendments in force at the time of application for type approval shall apply to this standard.

- 3.9.3. The colour shall be measured according to the conditions specified in D-10 of Annex D.

- 3.9.4. The minimum red content of a gas-discharge light source emitting white light shall be such that:

$$k_{\text{red}} = \frac{\int_{\lambda=610 \text{ nm}}^{780 \text{ nm}} E_e(\lambda) \cdot V(\lambda) \cdot d\lambda}{\int_{\lambda=380 \text{ nm}}^{780 \text{ nm}} E_e(\lambda) \cdot V(\lambda) \cdot d\lambda} \geq 0.05$$

where:

$E_e(\lambda)$ [W/nm] is the spectral distribution of the radiant flux;
 $V(\lambda)$ [1] is the spectral luminous efficiency;
 λ [nm] is the wave length.

This value shall be calculated using intervals of one nanometre.

3.10. UV radiation

The UV radiation of the gas-discharge light source shall be such that the gas discharge light source is of the low UV type complying with:

$$k_{\text{UV}} = \frac{\int_{\lambda=250 \text{ nm}}^{400 \text{ nm}} E_e(\lambda) \cdot S(\lambda) \cdot d\lambda}{k_m \cdot \int_{\lambda=380 \text{ nm}}^{780 \text{ nm}} E_e(\lambda) \cdot V(\lambda) \cdot d\lambda} \leq 10^{-5} \text{ W/lm}$$

where:

$S(\lambda)$ [1] is the spectral weighting function;
 $k_m = 683$ [lm/W] is the photometric radiation equivalent;

(For definitions of other symbols see 3.9 above).

This value shall be calculated using intervals of one nanometre.

The UV-radiation shall be weighted according to the values as indicated in the following table.

λ	$S(\lambda)$	λ	$S(\lambda)$	λ	$S(\lambda)$
250	0.430	305	0.060	355	0.00016
255	0.520	310	0.015	360	0.00013

Draft AIS-034 (Part 2) (Rev.3) :2022/D1
June 2023

260	0.650	315	0.003	365	0.00011
265	0.810	320	0.001	370	0.000090
270	1.000	325	0.00050	375	0.000077
275	0.960	330	0.00041	380	0.000064
280	0.880	335	0.00034	385	0.000053
285	0.770	340	0.00028	390	0.000044
290	0.640	345	0.00024	395	0.000036
295	0.540	350	0.00020	400	0.000030
300	0.300				

Wavelengths chosen are representative; other values should be interpolated.

Values according to "IRPA/INIRC Guidelines on limits of exposure to ultraviolet radiation".

3.11. Standard gas-discharge light sources

Standard (etalon) gas-discharge light sources shall comply with the requirements applicable to type approval light sources and to the specific requirements as stated in the relevant data sheet. In case of a type emitting white and selective yellow light, the standard light source shall emit white light.

4. CONFORMITY OF PRODUCTION

The conformity of production procedures shall comply with those set out in the AIS-037 with the following requirements:

- 4.1. Gas discharge light source approved under this standard shall be so manufactured as to conform to the type approved by meeting the requirements set forth in clause 3 above and Annex A and 2.4.2.
- 4.2. The minimum requirements for quality control procedures by the manufacturer set fourth in Annex F to this standard shall be complied with.
- 4.3. Analyse the results of each type of test shall be carried out applying criteria of Annex G, in order to verify and ensure the stability of the product characteristics making allowance for variation of an industrial production.
- 4.4. The minimum requirements for sampling by testing agency are set forth in Annex H to this standard shall be complied with.
- 4.5. The normal frequency of these verifications shall be once every two years.

5. PENALTIES FOR NON-CONFORMITY OF PRODUCTION

- 5.1. Penalties for non-conformity of production shall be as per AIS-037.
- 5.2. Reserved.

Draft AIS-034 (Part 2) (Rev.3) :2022/D1
June 2023

6. **Reserved.**

7. **Reserved.**

8. **TRANSITIONAL PROVISIONS**

8.1 At the request of the applicant, type approvals for compliance to AIS-034 (Part 2) (Rev.2 ~~3~~):~~2021~~ 2022, shall be granted by test agencies from the date of adoption in CMVR-TSC. Such type approvals shall be deemed to be compliance to AIS-034 (Part 2) (Rev.1):2010.

8.2 At the request of applicant, type approval to the compliance to AIS-034 (Part 2) (Rev.1):2010 shall be granted up to the notified date of implementation of AIS-034 (Part 2) (Rev.2 ~~3~~):~~2021~~ 2022.

8.3 Type approvals issued for compliance to AIS-034 (Part 2) (Rev.1):2010 shall be extended to approval of AIS-034 (Part 2) (Rev.2 ~~3~~):~~2021~~ 2022 subject to satisfactory compliance of the following:

8.3.1 In case of “E/e” approved devices, requirements specified in clause 10.

8.3.2 Verification of clause 3.6 and Annex D

Note: Additional verification for the above need not be carried out, if compliance to the above requirements has already been established during the type approval as per AIS-034 (Part 2) (Rev.1):2010.

8.4 Extension of Approvals for engineering and administrative changes:

8.4.1 In the case of 8.1, extensions shall be granted subject to the conditions of AIS-034 (Part 2) (Rev.2 ~~3~~):~~2021~~ 2022. Such extensions shall be deemed to be compliance to AIS-034 (Part 2) (Rev.1):2010.

8.4.2 In the case of 8.2, extensions shall be granted subject to conditions of AIS-034 (Part 2) (Rev.1):2010 till the notified date of implementation of AIS-034 (Part 2) (Rev.2 ~~3~~):~~2021~~ 2022.

8.5 Type approvals for compliance to AIS-037, already been granted, shall continue to be valid for AIS-034 (Part 2) (Rev.2 ~~3~~):~~2021~~ 2022.

Note: Necessary corrections to the reference of verification reports as per this standard shall be incorporated while issuing the next COP certificate. In the mean time for issuing of vehicle certificate, test/verification report as per this standard shall deemed to be the proof of compliance of AIS-037.

9. **EXTENSION OF TYPE APPROVAL**

9.1 Every modification pertaining to the information, even if the changes are not technical in nature declared in accordance with clause 2.2.2 shall be intimated by the manufacturer to the testing agency.

Draft AIS-034 (Part 2) (Rev.3) :2022/D1
June 2023

If the changes are in parameters not related to the provisions, no further action need be taken.

If the changes are in parameters related to the provisions, the testing agency, which has issued the certificate of compliance, shall then consider, whether,

9.1.1 the gas discharge light source with the changed specifications still complies with provisions, or

9.1.2 Any further verification is required to establish compliance.

9.2 For considering whether testing is required or not, guidelines given in clause 9.5 (Criteria for Extension of Approval) shall be used.

9.3 In case of clause 9.1.2, tests for only those parameters which are affected by the modifications need be carried out

9.4 In case of fulfilment of criterion of clause 9.1.1 or after results of further verification as per clause 9.1.2 are satisfactory, the approval of compliance shall be extended for the changes carried out.

9.5 Criteria for extension of approval

The Criteria shall be as agreed between the testing agency and applicant.

10 ESTABLISHING COMPLIANCE OF “E”/“e” APPROVED GAS DISCHARGE LIGHT SOURCE TO THIS STANDARD

10.1 As an exception to clause 7.4 of AIS-037, (or related administrative decisions) for certifying compliance of “E”/“e” approved gas discharge light source to this standard shall comply, the test for objective values Luminous flux as specified in relevant specification.

11 AMENDMENTS TO ECE REGULATIONS AFTER THE LEVEL DESCRIBED IN 0.3 OF FOREWORD

11.1 Supplements

In case of changes in ECE regulation, which are issued as supplements (Supplements do not affect the earlier type approvals) at the request of applicant, approval of compliance to this standard shall be issued taking into account the changes arising out of such supplement(s) to ECE regulation with approval from Chairman AISC.

This shall be incorporated in the test report.

Note: Such changes will be considered for inclusion in this standard at the time of its next amendment /revision.

11.2 Series of amendments

Changes in ECE regulation, which are issued as series of amendments (series of amendments may affect the earlier type approvals) will not be considered for issuing approval to this standard.

Draft AIS-034 (Part 2) (Rev.3) :2022/D1
June 2023

However, Chairman, AISC may, on a case to case basis, permit to accept latest series of amendments.
This shall be incorporated in the test report.

Note: Such changes will be considered for inclusion in this standard at the time of its next revision.

- 11.3 Acceptance of changes in UN regulations after the level described in 0.3 of introduction shall be as per AIS-000, as amended from time to time, as applicable, unless otherwise stated.

ANNEX A

(See clause 3.3.3.)

SHEETS FOR GAS-DISCHARGE LIGHT SOURCES

List of categories of gas-discharge light sources and their sheet numbers:

Gas-discharge light source categories only for use in passing beam, driving beam and cut-off front fog lamps:

Light source category	Sheet numbers
D1R	DxR/1 to 7
D1S	DxS/1 to 6
D2R	DxR/1 to 7
D2S	DxS/1 to 6
D3R	DxR/1 to 7
D3S	DxS/1 to 6
D4R	DxR/1 to 7
D4S	DxS/1 to 6
D5S	D5S/1 to 5
D6S	D6S/1 to 5
D8R	D8R/1 to 6
D8S	D8S/1 to 5
D9S	D9S/1 to 5

List of sheets for gas-discharge light sources and their sequence in this annex:

Sheet numbers
DxR/1 to 7 (Sheet DxR/6 2 pages)
DxS/1 to 6
D5S/1 to 5
D6S/1 to 5
D8R/1 to 6
D8S/1 to 5
D9S/1 to 5

CATEGORIES D1R, D2R, D3R AND D4R **Sheet DxR/1**

The drawings are intended only to illustrate the essential dimensions (in mm) of the gas-discharge light source

Figure 1

Category D1R - Type with cables - Cap PK32d-3

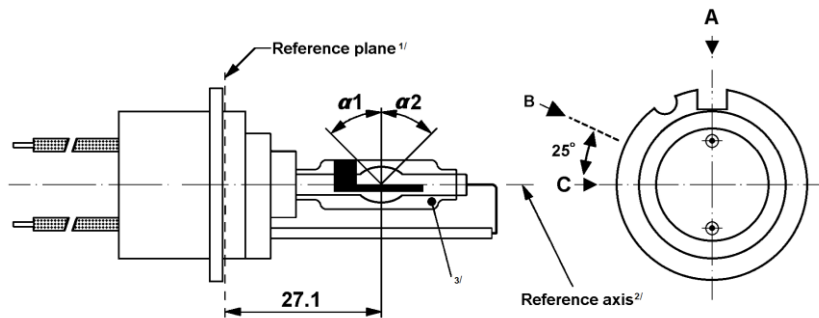
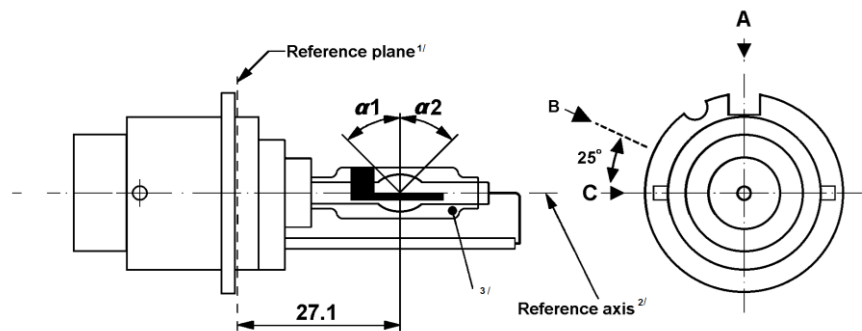

Figure 2

Category D2R - Type with connector - Cap P32d-3



- 1/ The reference plane is defined by the positions on the surface of the holder on which the three supporting bosses of the cap ring will rest.
- 2/ See sheet DxR/3.
- 3/ With respect to the reference axis, when measured at a distance of 27.1 mm from the reference plane the eccentricity of the outer bulb shall be less than ± 0.5 mm in direction C and less than $+ 1$ mm $- 0.5$ mm in direction A.

CATEGORIES D1R, D2R, D3R AND D4R

Sheet DxR/2

The drawings are intended only to illustrate the essential dimensions (in mm)
of the gas-discharge light source

Figure3
Category D3R - Type with starter – Cap PK32d-6

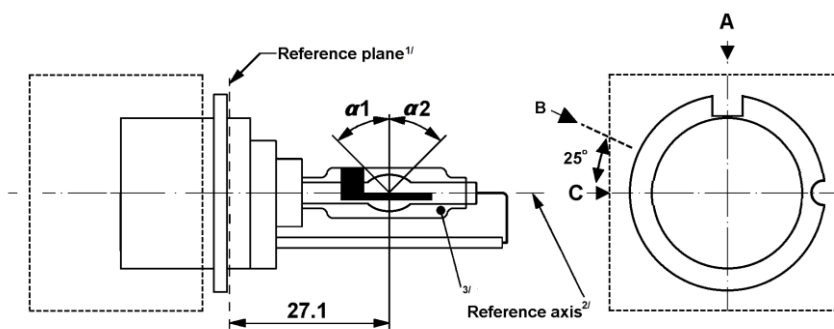
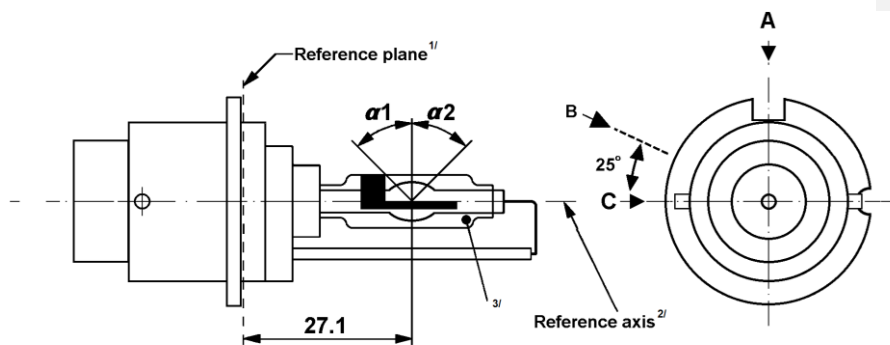

Figure 4
Category D4R - Type with connector – Cap P32d-6



1/ The reference plane is defined by the positions on the surface of the holder on which the three supporting bosses of the cap ring will rest.

2/ See sheet DxR/3.

Draft AIS-034 (Part 2) (Rev.3) :2022/D1
June 2023

- 3/ With respect to the reference axis, when measured at a distance of 27.1 mm from the reference plane the eccentricity of the outer bulb shall be less than ± 0.5 mm in direction C and less than + 1 mm /- 0.5 mm in direction A.

Figure 5
Definition of reference axis ^{1/}

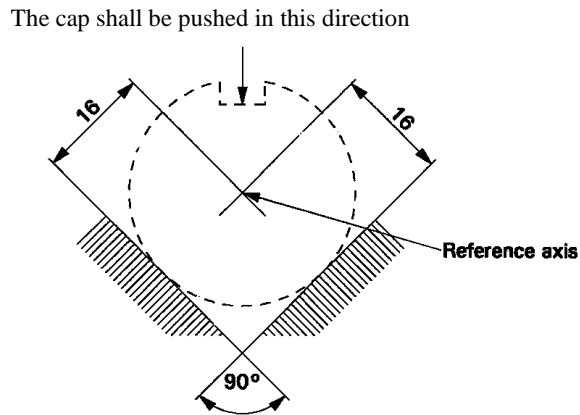
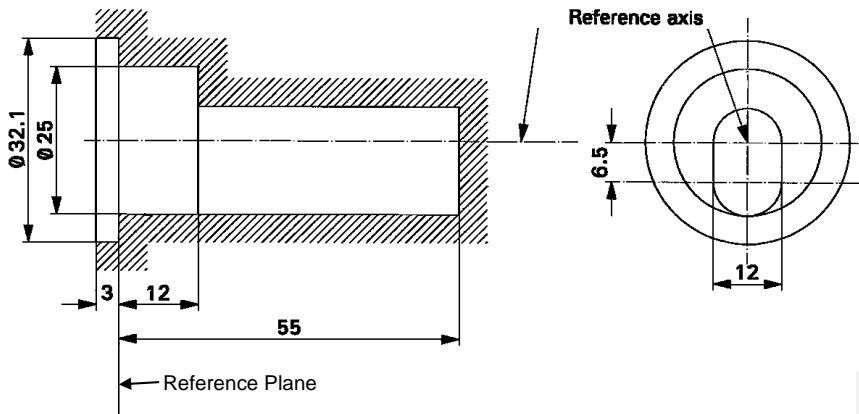

Figure 6
Maximum lamp outline ^{2/}



-
- ^{1/} The reference axis is perpendicular to the reference plane and crosses the intersection of the two parallel lines as indicated in figure 5.
- ^{2/} Glass bulb and supports shall not exceed the envelope, as indicated in figure 6. The envelope is concentric with the reference axis.

Draft AIS-034 (Part 2) (Rev.3) :2022/D1
June 2023

CATEGORIES D1R, D2R, D3R AND D4R Sheet DxR/4

Dimensions		Production light sources	Standard light sources			
Position of electrodes		Sheet DxR/5				
Position and form of the arc		Sheet DxR/6				
Position of the black stripes		Sheet DxR/7				
$\alpha 1$ ^{1/}		$45^\circ \pm 5^\circ$				
$\alpha 2$ ^{1/}		45° min.				
D1R: Cap PK32d-3 D2R: Cap P32d-3 D3R: Cap PK32d-6 D4R: Cap P32d-6		in accordance with IEC Publication 60061 (sheet 7004-111-5)				
ELECTRICAL AND PHOTOMETRIC CHARACTERISTICS						
		D1R/D2R	D3R/D4R	D1R/D2R	D3R/D4R	
Rated voltage of the ballast	V	12 ^{2/}		12		
Rated wattage	W	35		35		
Test voltage	V	13.5		13.5		
Lamp voltage	Objective	V	85	42	85	42
	Tolerance		± 17	± 9	± 8	± 4
Lamp wattage	Objective	W	35		35	
	Tolerance		± 3		± 0.5	
Luminous flux	Objective	lm	2800		2800	
	Tolerance		± 450		± 150	
Chromaticity coordinates	Objective		x = 0.375		y = 0.375	
	Tolerance area ^{3/}	Boundaries	x = 0.345		y = 0.150 + 0.640 x	
			x = 0.405		y = 0.050 + 0.750 x	
		Intersection points	x = 0.345		y = 0.371	
x = 0.405			y = 0.409			
x = 0.405			y = 0.354			
Hot-restrike switch-off time		s	10		10	

^{1/} The part of the bulb within the angles $\alpha 1$ and $\alpha 2$ shall be the light emitting part. This part shall be as homogeneous in form as possible and shall be optically distortion free. This applies to the whole bulb circumference within the angles $\alpha 1$ and $\alpha 2$ except for the black stripes.

^{2/} Application voltages of ballasts may differ from 12 V.

Draft AIS-034 (Part 2) (Rev.3) :2022/D1
June 2023

3/ See Annex D.

CATEGORIES D1R, D2R, D3R AND D4R Sheet DxR/5

Position of the electrodes

This test is used to determine whether the electrodes are correctly positioned

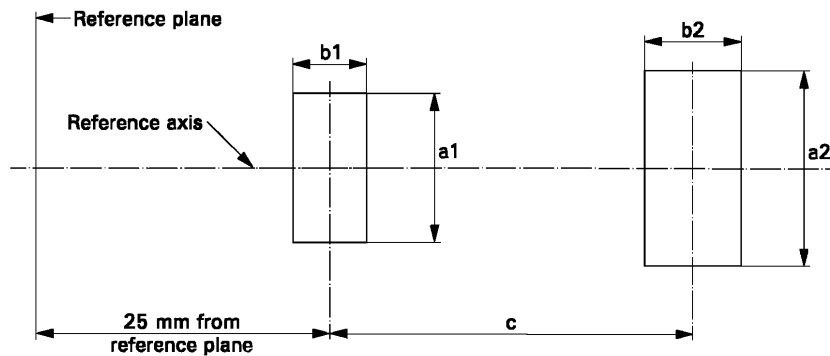

relative to the reference axis and the reference plane.

Measuring direction: light source side and top view

Dimension in mm	Production light sources	Standard light sources
a1	$d + 0.5$	$d + 0.2$
a2	$d + 0.7$	$d + 0.35$
b1	0.4	0.15
b2	0.8	0.3
c	4.2	4.2

d = diameter of the electrode;
 $d < 0.3$ for D1R and D2R;
 $d < 0.4$ for D3R and D4R.

The top of the electrode nearest to the reference plane shall be positioned in the area defined by $a1$ and $b1$. The top of the electrode furthest from the reference plane shall be positioned in the area defined by $a2$ and $b2$.

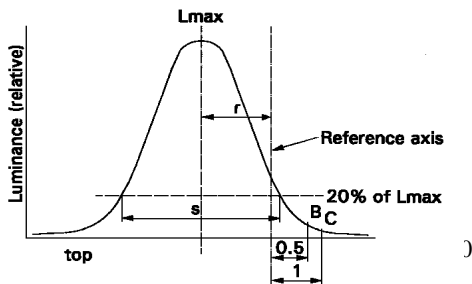

Relative luminance distribution
in the central cross section D.

Determination of:

- arc bending r
- arc diffusion s
- Luminance L_{max}

Position and form of the arc

This test is used to determine the form and sharpness of the arc and its position relative to the reference axis and plane by determining its bending and diffusion; by measuring the luminance in the central cross section D, where L_{max_c} is the maximum luminance of the arc measured from viewing direction C; see sheet DxR/2.

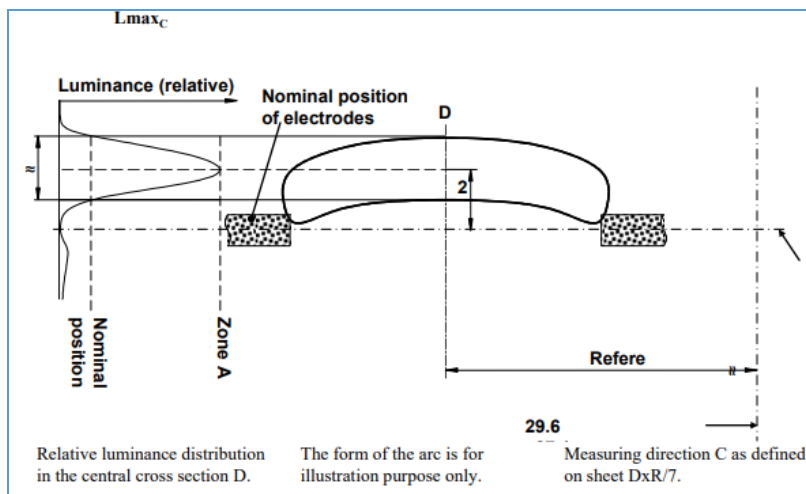

When measuring the relative luminance distribution in the central cross section D as indicated in the drawing above, the maximum value L_{max_c} has the distance r from the reference axis. The points of 20% of L_{max_c} have the distance s , as shown in the drawing below.

Dimension in mm	Production light sources		Standard light sources
	D1R/D2R	D3R/D4R	
R (arc bending)	0.50 ± 0.25	0.50 ± 0.25	0.50 ± 0.20
S (arc diffusion)	1.10 ± 0.25	$1.10 + 0.25/-0.40$	1.10 ± 0.25

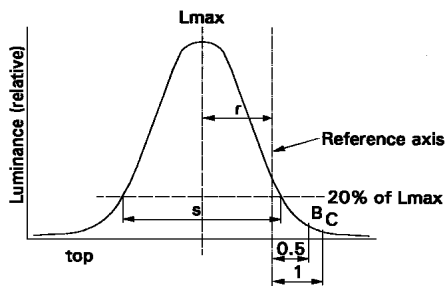

Relative luminance distribution in the central cross section D.
 Determination of:

- arc bending r
- arc diffusion s
- Luminance L_{max}

Stray light

This test is used to determine unwanted reflected stray light by measuring the luminance in Zone A and at lines B and C, where L_{maxB} is the maximum luminance of the arc measured from viewing direction B; see sheet DxR/2.

L_{maxB}

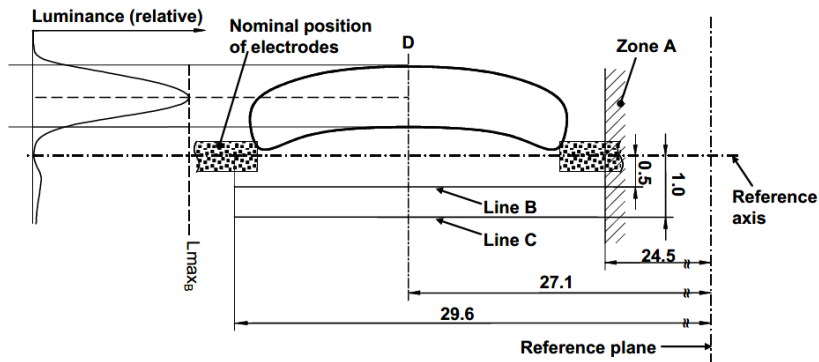

Relative luminance distribution in the central cross section D.

The form of the arc is for illustration purpose only.

Measuring direction B as defined on sheet DxR/7.

When measuring the luminances from measuring direction B as defined on sheet DxR/7 with a set-up as outlined in Annex E, however with a circular field of 0.2M mm diameter, the relative luminance expressed as a percentage of L_{maxB} (at cross section D) shall be:

Zone A	≤ 4.5 %	Line B	≤ 15 %	Line C	≤ 5.0 %
--------	---------	--------	--------	--------	---------

The area of zone A is defined by the black coating, the outer bulb and a plane at 24.5 mm from the reference plane.

CATEGORIES D1R, D2R, D3R AND D4R Sheet DxR/7

Position of black stripes

This test is used to determine whether the black stripes are correctly positioned relative to the reference axis and the reference plane.

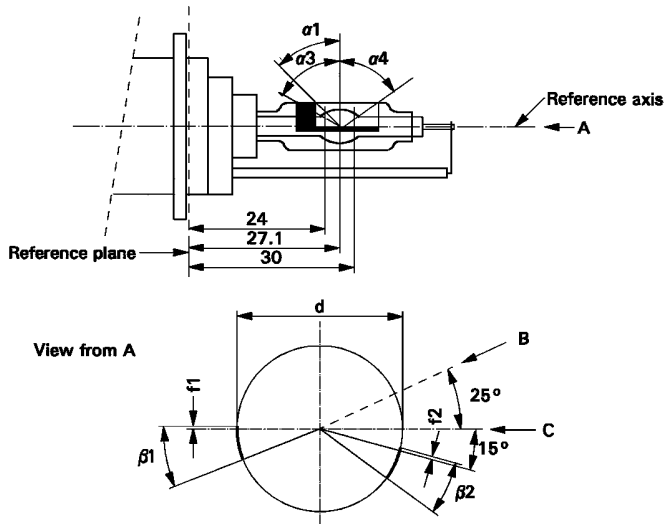

When measuring the luminance distribution of the arc in the central cross section as defined on sheet DxR/6, after having turned the light source so that the black stripe is covering the arc, the measured luminance shall be $\leq 0.5\%$ of L_{max} .

In the area defined by $\alpha 1$ and $\alpha 3$ the black coating may be replaced by any other means which prevents light transmission through the specified area.

Dimensions	Production light sources	Standard light sources
$\alpha 1$	$45^\circ \pm 5^\circ$	
$\alpha 3$	70° min.	
$\alpha 4$	65° min.	
$\beta 1/24, \beta 1/30, \beta 2/24, \beta 2/30$	$25^\circ \pm 5^\circ$	
$f1/24, f2/24$ ^{1/}	0.15 ± 0.25	0.15 ± 0.20
$f1/30$ ^{1/}	$f1/24$ mv ± 0.15 ^{2/}	$f1/24$ mv ± 0.1
$f2/30$ ^{1/}	$f2/24$ mv ± 0.15 ^{2/}	$f2/24$ mv ± 0.1
$f1/24$ mv - $f2/24$ mv	± 0.3 max.	± 0.2 max.
d	9 ± 1	

^{1/} "f1/.." means dimension f1 to be measured at the distance from the reference plane indicated in mm after the stroke.

Draft AIS-034 (Part 2) (Rev.3) :2022/D1
June 2023

2/ ".../24 mv" means the value measured at a distance of 24 mm from the reference plane.

CATEGORIES D1S, D2S, D3S AND D4S **Sheet DxS/1**

The drawings are intended only to illustrate the essential dimensions (in mm)
of the gas-discharge light source

Figure 1

Category D1S - Type with cables - Cap PK32d-2

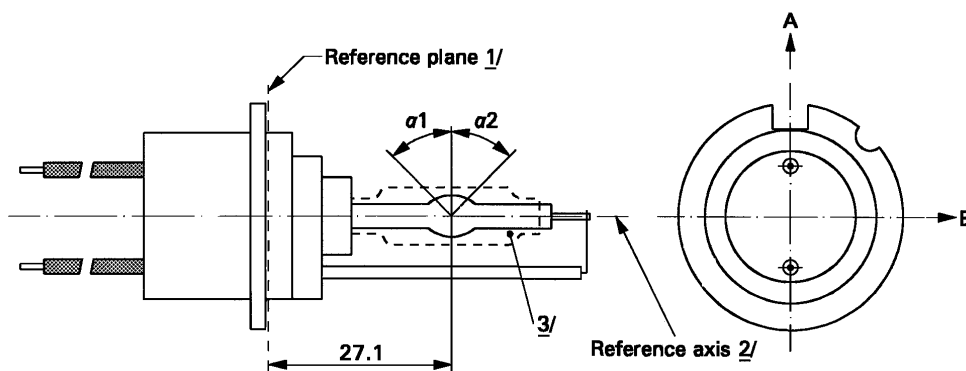
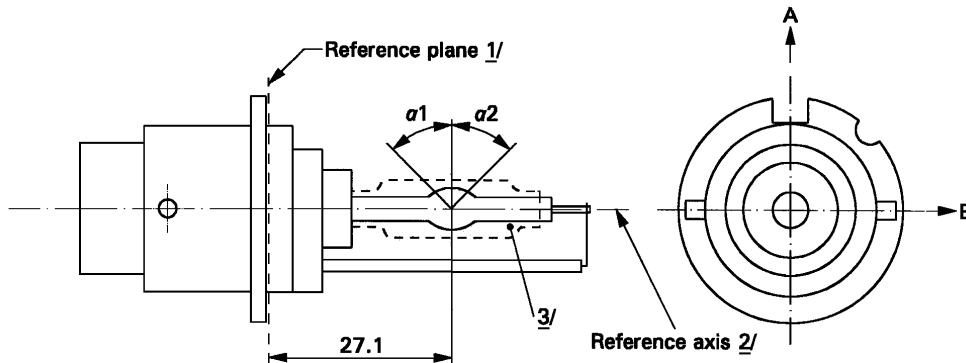

Figure 2

Category D2S - Type with connector - Cap P32d-2



1/ The reference plane is defined by the positions on the surface of the holder on which the three supporting bosses of the cap ring will rest.

2/ See sheet DxS/3.

3/ When measured at a distance of 27.1 mm from the reference plane and with respect to the mid-point of the inner bulb, the outer bulb shall have an eccentricity of 1 mm max.

CATEGORIES D1S, D2S, D3S AND D4S Sheet DxS/2

The drawings are intended only to illustrate the essential dimensions (in mm) of the gas-discharge light source

Figure 3
Category D3S - Type with starter - Cap PK32d-5

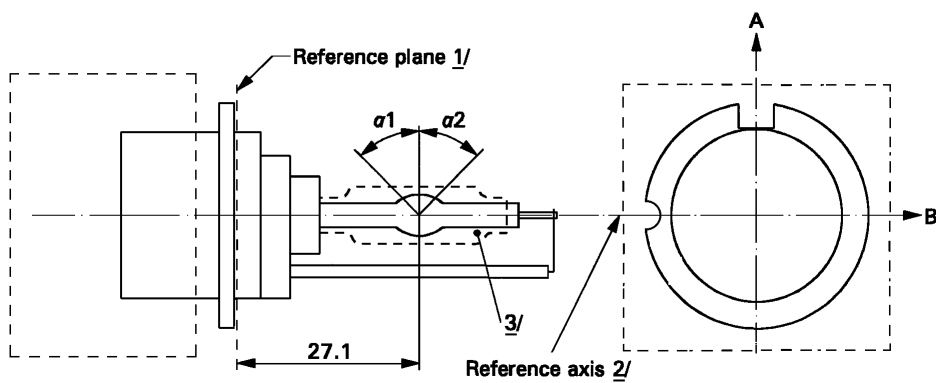
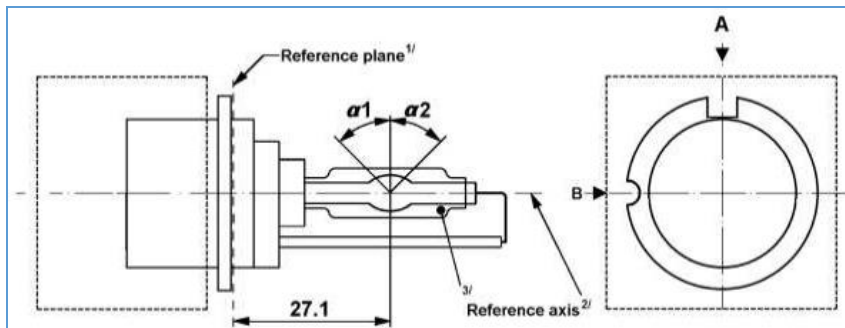

Figure 4
Category D4S - Type with connector - Cap P32d-5



-
- 1/ The reference plane is defined by the positions on the surface of the holder on which the three supporting bosses of the cap ring will rest.
 - 2/ See sheet DxS/3.
 - 3/ When measured at a distance of 27.1 mm from the reference plane and with respect to the mid-point of the inner bulb, the outer bulb shall have an eccentricity of 1 mm max.

Figure 5
Definition of reference axis ^{1/}

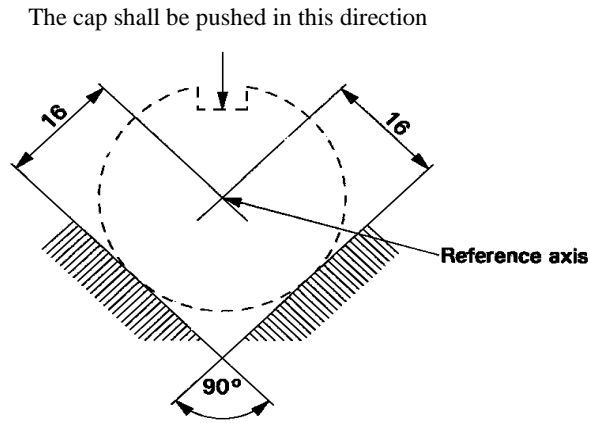
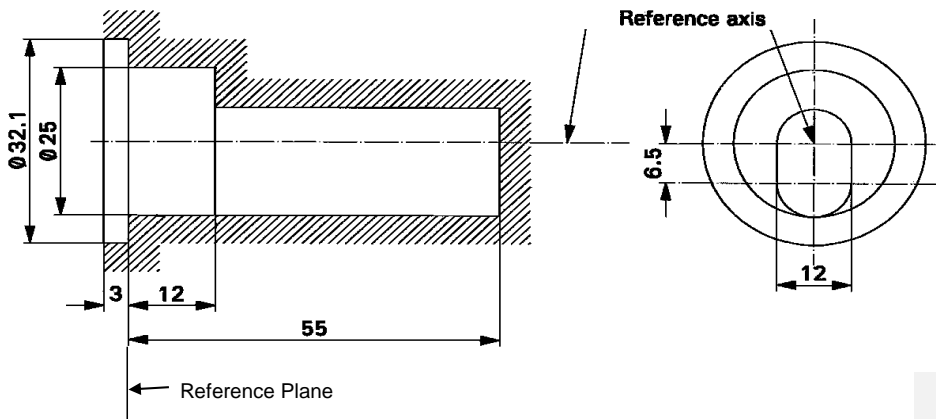

Figure 6
Maximum lamp outline ^{2/}



^{1/} The reference axis is perpendicular to the reference plane and crosses the intersection of the two parallel lines as indicated in figure 5.

Draft AIS-034 (Part 2) (Rev.3) :2022/D1
June 2023

- 2/ Glass bulb and supports shall not exceed the envelope, as indicated in figure 6.
The envelope is concentric with the reference axis.

Draft AIS-034 (Part 2) (Rev.3) :2022/D1
June 2023

CATEGORIES D1S, D2S, D3S AND D4S

Sheet DxS/4

Dimensions		Production light sources	Standard light sources			
Position of electrodes		Sheet DxS/5				
Position and form of the arc		Sheet DxS/6				
α_1, α_2 ^{1/}		55° min.	55° min.			
D1S: Cap PK32d-2 D2S: Cap P32d-2 D3S: Cap PK32d-5 D4S: Cap P32d-5						
in accordance with IEC Publication 60061 (sheet 7004-111-5)						
ELECTRICAL AND PHOTOMETRIC CHARACTERISTICS						
		D1S/D2S	D3S/D4S	D1S/D2S	D3S/D4S	
Rated voltage of the ballast	V	12 ^{2/}		12		
Rated wattage	W	35		35		
Test voltage	V	13.5		13.5		
Lamp voltage	Objective	85	42	85	42	
	Tolerance	± 17	± 9	± 8	± 4	
Lamp wattage	Objective	35		35		
	Tolerance	± 3		± 0.5		
Luminous flux	Objective	3200		3200		
	Tolerance	± 450		± 150		
Chromaticity coordinates	Objective	x = 0.375		y = 0.375		
	Tolerance area ^{3/}	Boundaries	x = 0.345		y = 0.150 + 0.640 x	
			x = 0.405		y = 0.050 + 0.750 x	
	Intersection points	x = 0.345		y = 0.371		
x = 0.405		y = 0.409				
x = 0.405		y = 0.354				
Hot-restrike switch-off time		s	10	10		

^{1/} The part of the bulb within the angles α_1 and α_2 shall be the light emitting part. This part shall be as homogeneous in form as possible and shall be optically distortion free. This applies to the whole bulb circumference within the angles α_1 and α_2 .

^{2/} Application voltages of ballasts may differ from 12 V.

^{3/} See Annex D.

Position of the electrodes

This test is used to determine whether the electrodes are correctly positioned relative to the reference axis and the reference plane.

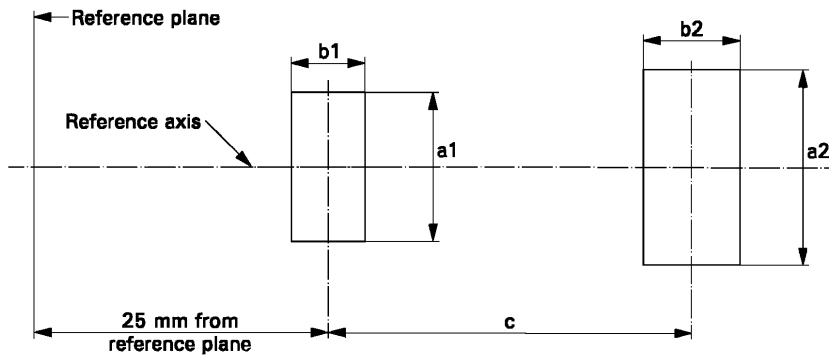

Measuring direction: light source side and top view

Dimension in mm	Production light sources	Standard light sources
a1	$d + 0.2$	$d + 0.1$
a2	$d + 0.5$	$d + 0.25$
b1	0.3	0.15
b2	0.6	0.3
c	4.2	4.2

d = diameter of the electrode;
d < 0.3 for D1S and D2S;
d < 0.4 for D3S and D4S.

The top of the electrode nearest to the reference plane shall be positioned in the area defined by a1 and b1. The top of the electrode furthest from the reference plane shall be positioned in the area defined by a2 and b2.

CATEGORIES D1S, D2S, D3S AND D4S Sheet DxS/6

Position and form of the arc

This test is used to determine the form of the arc and its position relative to the reference axis and the reference plane by measuring its bending and diffusion in the cross section at a distance 27.1 mm from the reference plane.

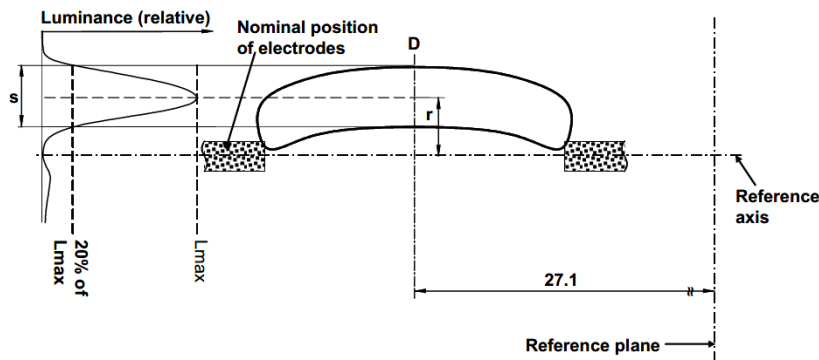

Relative luminance distribution in the central cross section D.

The form of the arc is for illustration purpose only.

Measuring direction B: light source side view

When measuring the relative luminance distribution in the central cross section as indicated in the drawing above, the maximum value shall be located within the distance r from the reference axis. The point of 20% of the maximum value shall be within s.

Dimension in mm	Production light sources	Standard light sources
r (arc bending)	0.50 ± 0.40	0.50 ± 0.20
s (arc diffusion)	1.10 ± 0.40	1.10 ± 0.25

Draft AIS-034 (Part 2) (Rev.3) :2022/D1
June 2023

The drawings are intended only to illustrate the essential dimensions (in mm) of the gas-discharge light source

Figure 1
Category D5S - Cap PK32d-7

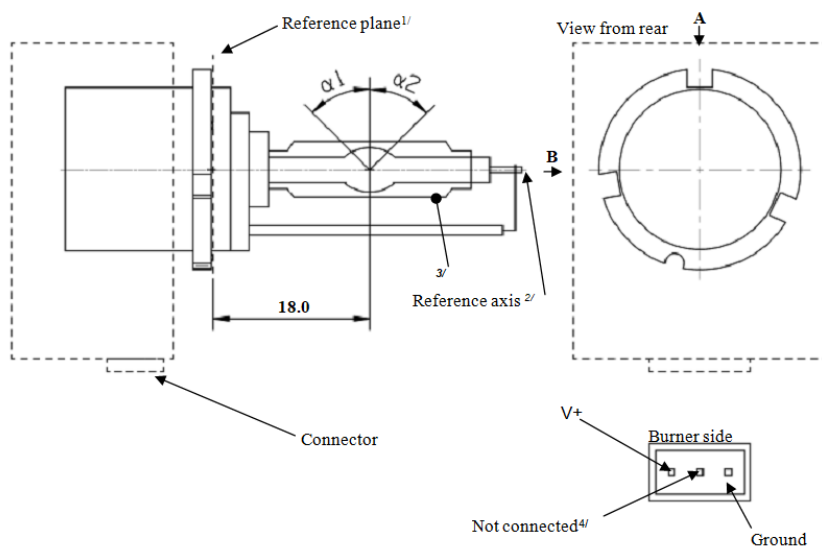

^{1/} The reference plane is defined by the positions on the surface of the holder on which the three supporting bosses of the cap ring will rest.

^{2/} See sheet D5S/2.

^{3/} When measured at a distance of 18.0 mm from the reference plane and with respect to the mid-point of the inner bulb, the outer bulb shall have an eccentricity of 1 mm max.

^{4/} Optional Pin.

Figure 2
Definition of reference axis^{1/}

The cap shall be pushed in this direction

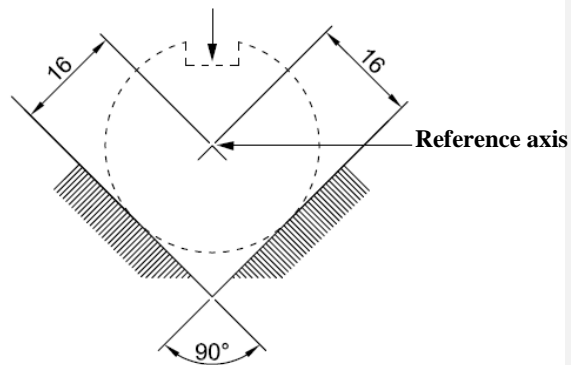
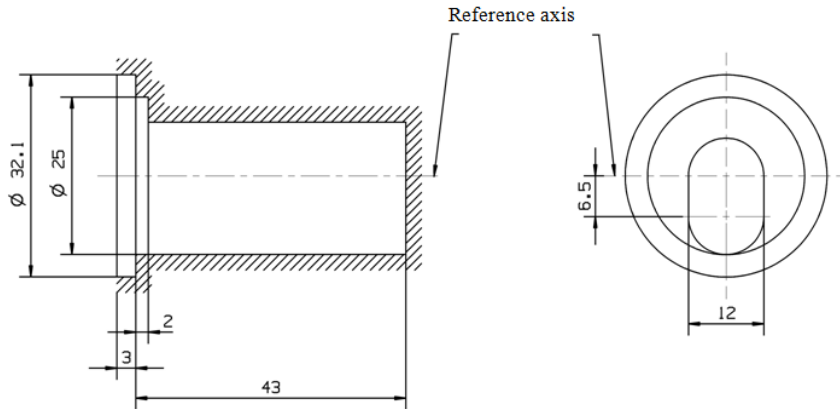

Figure 3
Maximum lamp outline^{2/}



^{1/} The reference axis is perpendicular to the reference plane and crosses the intersection of the two parallel lines as indicated in figure 2.

^{2/} Glass bulb and supports shall not exceed the envelope, as indicated in figure 3. The envelope is concentric with the reference axis.

Draft AIS-034 (Part 2) (Rev.3) :2022/D1
June 2023

Category D5S

Sheet D5S/3

<i>Dimensions</i>		<i>Production light sources</i>	<i>Standard light sources</i>
Position of the electrodes		Sheet D5S/4	
Position and form of the arc		Sheet D5S/5	
$\alpha_1, \alpha_2^{1/}$		55° min.	55° min.
D5S: Cap PK32d-7 in accordance with IEC Publication 60061 (sheet 7004-111-5)			
Electrical and photometric characteristics			
Rated voltage	V	12 / 24	12 / 24
Rated wattage	W	25	25
Test voltage	V	13.2 / 28	13.2 / 28
Objective lamp wattage ^{2/}	W	31 max.	31 max.
Chromaticity coordinates	Objective	x = 0.375	y = 0.375
	Tolerance area ^{3/}	Boundaries	x = 0.345 y = 0.150 + 0.640 x
			x = 0.405 y = 0.050 + 0.750 x
		Intersection points	x = 0.345 y = 0.371
			x = 0.405 y = 0.409
		x = 0.405 y = 0.354	
		x = 0.345 y = 0.309	
Objective Luminous flux	lm	2000 ± 300	2000 ± 100
Hot-restrike switch-off time	s	10	10

^{1/} The part of the bulb within the angles α_1 and α_2 shall be the light emitting part. This part shall be as homogeneous in form as possible and shall be optically distortion free. This applies to the whole bulb circumference within the angles α_1 and α_2 .

^{2/} Wattage of lamp with ballast integrated.

^{3/} See Annex D.

Position of the electrodes

This test is used to determine whether the electrodes are correctly positioned relative to the reference axis and the reference plane.

Top view (schematic):

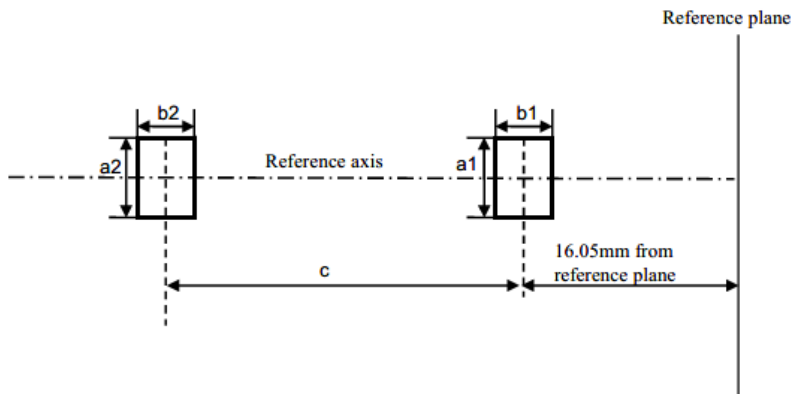

Side view (schematic):

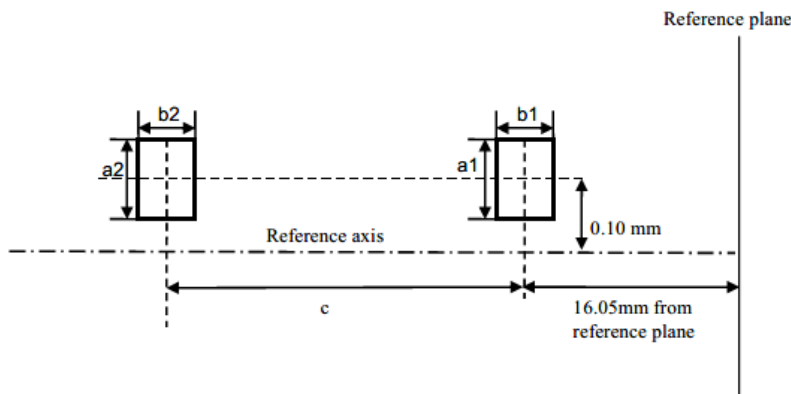

Measuring direction: light source side and top view

Dimension in mm	Production light sources	Standard light sources
a1	0.30	0.20
a2	0.50	0.25
b1	0.30	0.15
b2	0.60	0.30
c	3.90	3.90

The arc attachment point to the electrode nearest to the reference plane shall be positioned in the area defined by a1 and b1. The arc attachment point to the electrode furthest from the reference plane shall be positioned in the area defined by a2 and b2.

Position and form of the arc

This test is used to determine the form of the arc and its position relative to the reference axis and the reference plane by measuring its bending and diffusion in the cross section at a distance 18.0 mm from the reference plane.

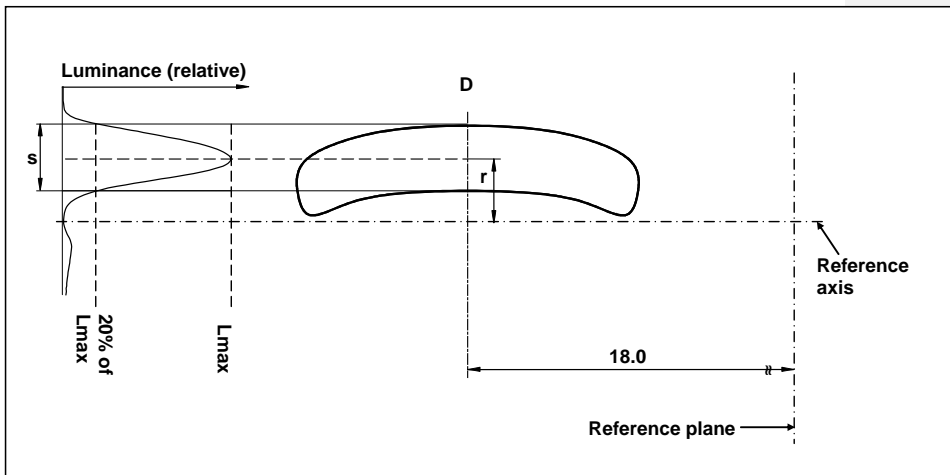

Relative luminance distribution in the central cross section D. The form of the arc is for illustration purpose only. Measuring direction: light source side view only.

When measuring the relative luminance distribution in the central cross section as indicated in the drawing above, the maximum value shall be located within the distance r from the reference axis. The point of 20 per cent of the maximum value shall be within s .

<i>Dimension in mm</i>	<i>Production light sources</i>	<i>Standard light sources</i>
r (arc bending)	0.50 +/-0.25	0.50 +/-0.15
s (arc diffusion)	0.70 +/-0.25	0.70 +/-0.15

The drawings are intended only to illustrate the essential dimensions (in mm) of the gas-discharge light source

Figure 1
Category D6S - Cap P32d-1

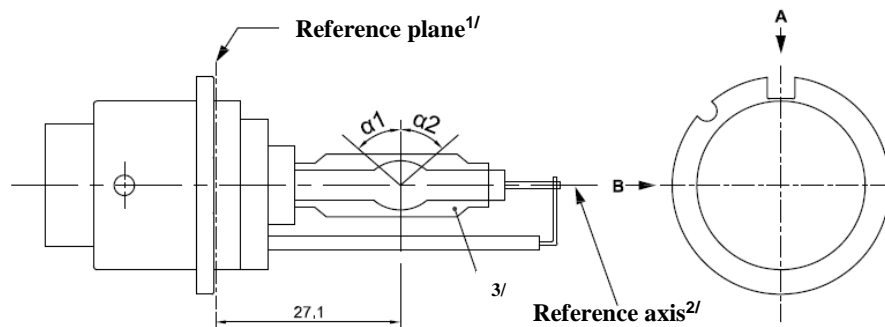

- ^{1/} The reference plane is defined by the positions on the surface of the holder on which the three supporting bosses of the cap ring will rest.
- ^{2/} See sheet D6S/2.
- ^{3/} When measured at a distance of 27.1 mm from the reference plane and with respect to the mid-point of the inner bulb, the outer bulb shall have an eccentricity of 1 mm max.

Figure 2
Definition of reference axis^{1/}

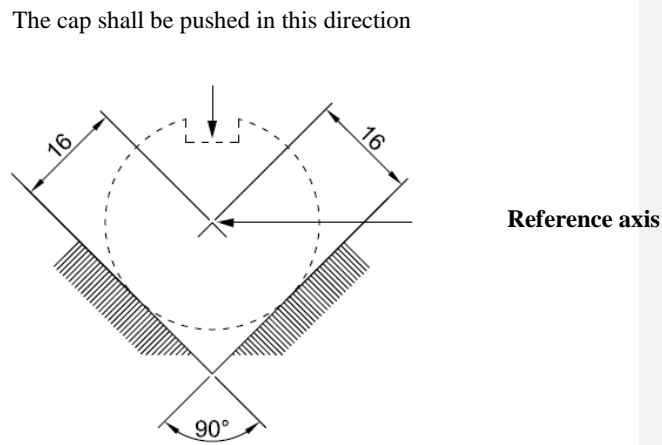
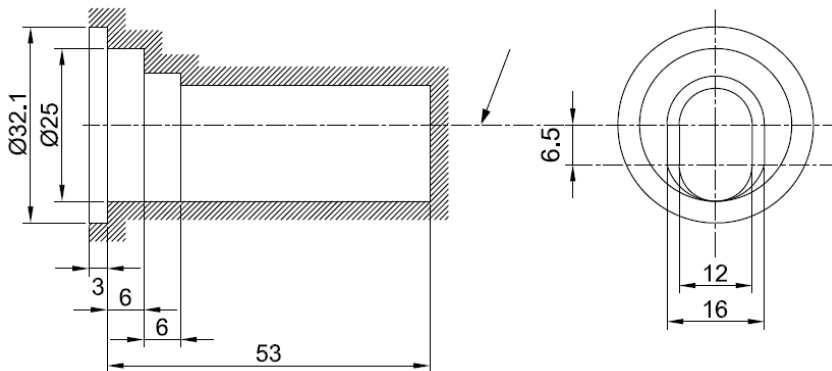

Figure 3
Maximum lamp outline^{2/}



Draft AIS-034 (Part 2) (Rev.3) :2022/D1
June 2023

- ^{1/} The reference axis is perpendicular to the reference plane and crosses the intersection of the two parallel lines as indicated in figure 2.
- ^{2/} Glass bulb and supports shall not exceed the envelope, as indicated in figure 3. The envelope is concentric with the reference axis.

Category D6S

Sheet D6S/3

<i>Dimensions</i>		<i>Production light sources</i>	<i>Standard light sources</i>
Position of the electrodes		Sheet D6S/4	
Position and form of the arc		Sheet D6S/5	
$\alpha_1, \alpha_2^{1/}$		55° min.	55° min.
D6S: Cap P32d-1 in accordance with IEC Publication 60061 (sheet 7004-111-5)			
Electrical and photometric characteristics			
Rated voltage of the ballast	V	12 ^{2/}	12
Rated wattage	W	25	25
Test voltage	V	13.2	13.2
Objective lamp voltage	V	42 ± 9	42 ± 4
Objective lamp wattage	W	25 ± 3	25 ± 0.5
Objective Luminous flux	lm	2000 ± 300	2000 ± 100
Chromaticity coordinates	Objective	x = 0.375	y = 0.375
	Tolerance area ^{3/}	Boundaries	x = 0.345 y = 0.150 + 0.640 x
			x = 0.405 y = 0.050 + 0.750 x
		Intersection points	x = 0.345 y = 0.371
			x = 0.405 y = 0.409
			x = 0.405 y = 0.354
x = 0.345 y = 0.309			
Hot-restrike switch-off time	s	10	10

^{1/} The part of the bulb within the angles α_1 and α_2 shall be the light emitting part. This part shall be as homogeneous in form as possible and shall be optically distortion free. This applies to the whole bulb circumference within the angles α_1 and α_2 .

^{2/} Application voltages of ballasts may differ from 12 V.

^{3/} See Annex D.

Position of the electrodes

This test is used to determine whether the electrodes are correctly positioned relative to the reference axis and the reference plane.

Top view (schematic):

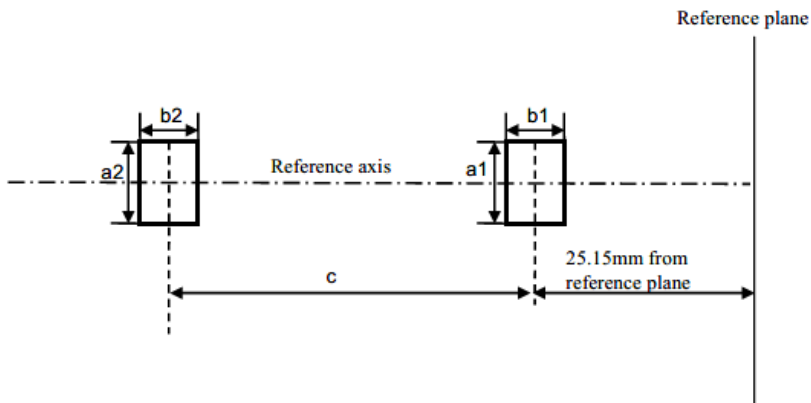

Side view (schematic):

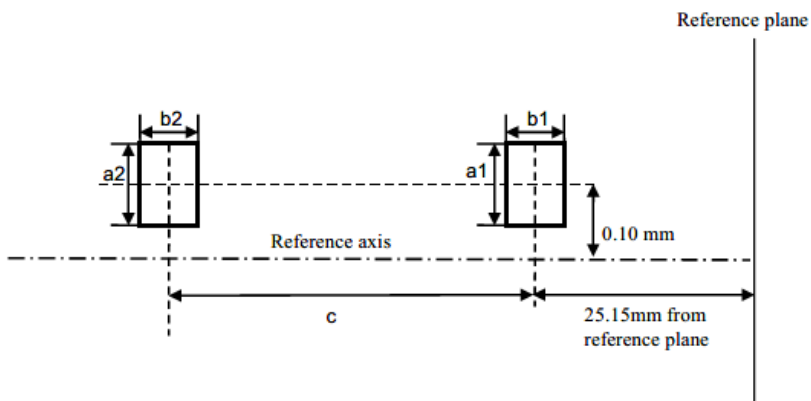

Measuring direction: light source side and top view

Draft AIS-034 (Part 2) (Rev.3) :2022/D1
June 2023

<i>Dimension in mm</i>	<i>Production light sources</i>	<i>Standard light sources</i>
a1	0.30	0.20
a2	0.50	0.25
b1	0.30	0.15
b2	0.60	0.30
c	3.90	3.90

The arc attachment point to the electrode nearest to the reference plane shall be positioned in the area defined by a1 and b1. The arc attachment point to the electrode furthest from the reference plane shall be positioned in the area defined by a2 and b2.

Position and form of the arc

This test is used to determine the form of the arc and its position relative to the reference axis and the reference plane by measuring its bending and diffusion in the cross section at a distance 27.1 mm from

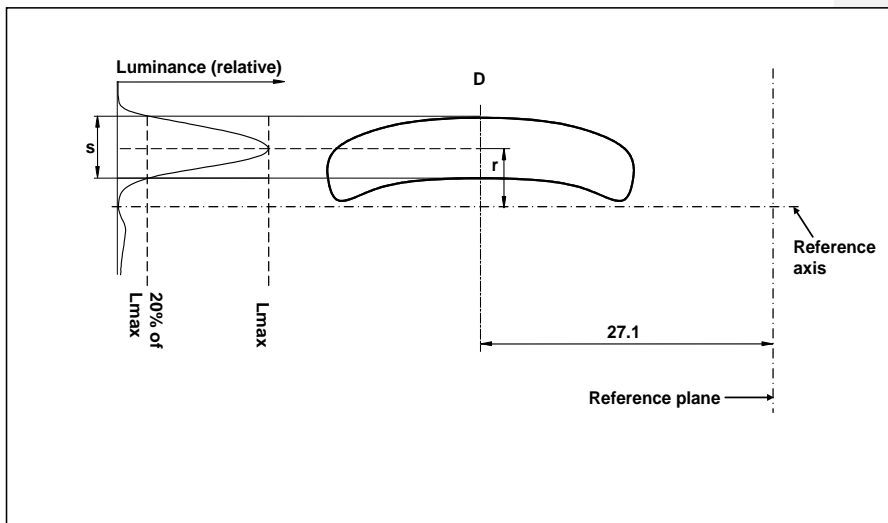

the reference plane.

Relative luminance distribution in the central cross section D. The form of the arc is for illustration purpose only. Measuring direction: light source side view only.

When measuring the relative luminance distribution in the central cross section as indicated in the drawing above, the maximum value shall be located within the distance r from the reference axis. The point of 20 per cent of the maximum value shall be within s.

<i>Dimension in mm</i>	<i>Production light sources</i>	<i>Standard light sources</i>
r (arc bending)	0.50 +/-0.25	0.50 +/-0.15
s (arc diffusion)	0.70 +/-0.25	0.70 +/-0.15

The drawings are intended only to illustrate the essential dimensions (in mm)

Figure 1
Category D8S - Cap PK32d-1

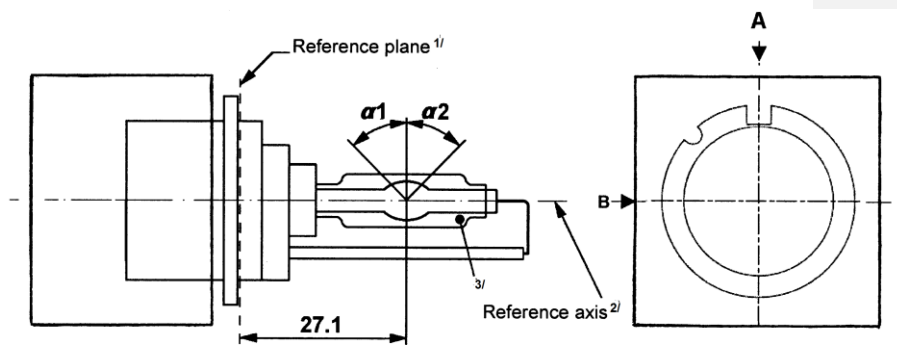

^{1/} The reference plane is defined by the positions on the surface of the holder on which the three supporting bosses of the cap ring will rest.

^{2/} See sheet D8S/2.

^{3/} When measured at a distance of 27.1 mm from the reference plane and with respect to the mid-point of the inner bulb, the outer bulb shall have an eccentricity of 1 mm max.

Figure 2
Definition of reference axis^{1/}

The cap shall be pushed in this direction

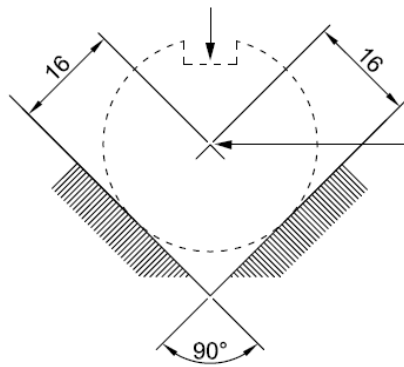
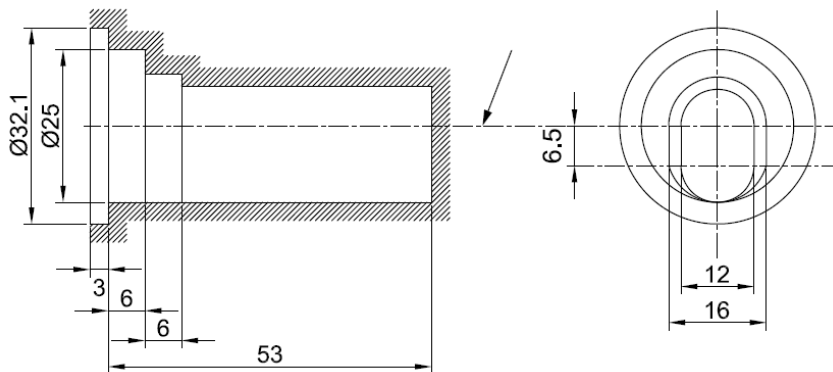

Figure 3
Maximum lamp outline^{2/}



- ^{1/} The reference axis is perpendicular to the reference plane and crosses the intersection of the two parallel lines as indicated in figure 2.
- ^{2/} Glass bulb and supports shall not exceed the envelope, as indicated in figure 3. The envelope is concentric with the reference axis.

Draft AIS-034 (Part 2) (Rev.3) :2022/D1
June 2023

Category D8S

Sheet D8S/3

<i>Dimensions</i>		<i>Production light sources</i>	<i>Standard light sources</i>
Position of the electrodes		Sheet D8S/4	
Position and form of the arc		Sheet D8S/5	
$\alpha_1, \alpha_2^{1/}$		55° min.	55° min.
D8S: Cap PK32d-1 in accordance with IEC Publication 60061 (sheet 7004-111-5)			
Electrical and photometric characteristics			
Rated voltage of the ballast	V	12 ^{2/}	12
Rated wattage	W	25	25
Test voltage	V	13.2	13.2
Objective lamp voltage	V	42 ± 9	42 ± 4
Objective lamp wattage	W	25 ± 3	25 ± 0.5
Objective Luminous flux	lm	2000 ± 300	2000 ± 100
Chromaticity coordinates	Objective	x = 0.375	y = 0.375
	Tolerance area ^{3/}	Boundaries	x = 0.345 y = 0.150 + 0.640 x
			x = 0.405 y = 0.050 + 0.750 x
		Intersection points	x = 0.345 y = 0.371
			x = 0.405 y = 0.409
			x = 0.405 y = 0.354
x = 0.345 y = 0.309			
Hot-restrike switch-off time	s	10	10

^{1/} The part of the bulb within the angles α_1 and α_2 shall be the light emitting part. This part shall be as homogeneous in form as possible and shall be optically distortion free. This applies to the whole bulb circumference within the angles α_1 and α_2 .

^{2/} Application voltages of ballasts may differ from 12 V.

^{3/} See Annex D.

Draft AIS-034 (Part 2) (Rev.3) :2022/D1
June 2023

Category D8S

Sheet D8S/4

Position of the electrodes

This test is used to determine whether the electrodes are correctly positioned relative to the reference axis and the reference plane.

Top view (schematic):

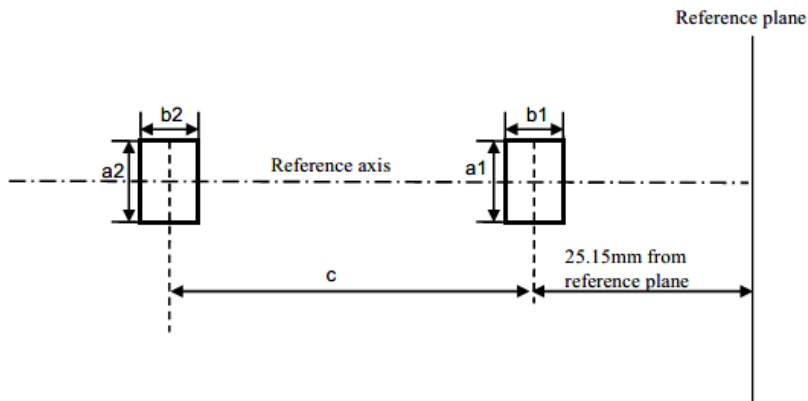

Side view (schematic):

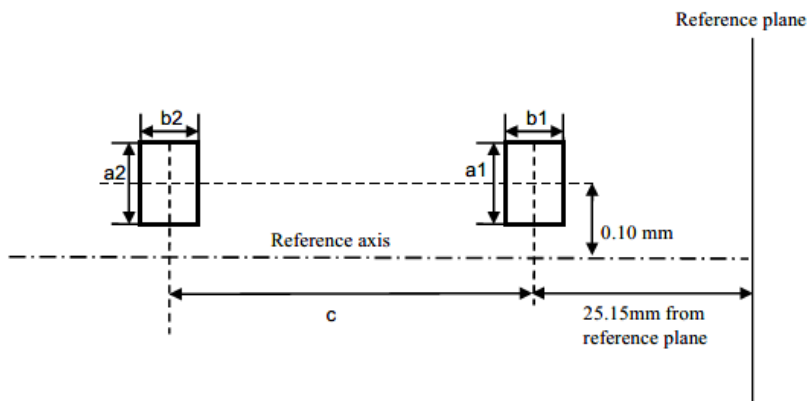

Measuring direction: light source side and top view

Dimension in mm	Production light sources	Standard light sources
a1	0.30	0.20
a2	0.50	0.25
b1	0.30	0.15
b2	0.60	0.30
c	3.90	3.90

The arc attachment point to the electrode nearest to the reference plane shall be positioned in the area defined by a1 and b1. The arc attachment point to the electrode furthest from the reference plane shall be positioned in the area defined by a2 and b2.

Position and form of the arc

This test is used to determine the form of the arc and its position relative to the reference axis and the reference plane by measuring its bending and diffusion in the cross section at a distance 27.1 mm from the reference plane.

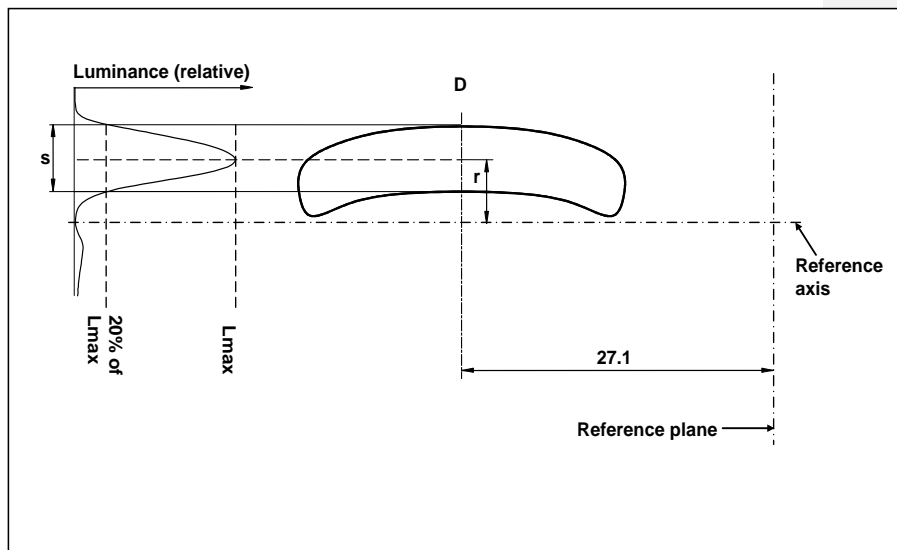

Relative luminance distribution in the central cross section D. The form of the arc is for illustration purpose only. Measuring direction: light source side view

When measuring the relative luminance distribution in the central cross section as indicated in the drawing above, the maximum value shall be located within the distance r from the reference axis. The point of 20 per cent of the maximum value shall be within s .

<i>Dimension in mm</i>	<i>Production light sources</i>	<i>Standard light sources</i>
r (arc bending)	0.50 +/- 0.25	0.50 +/- 0.15
s (arc diffusion)	0.70 +/- 0.25	0.70 +/- 0.15

The drawings are intended only to illustrate the essential dimensions (in mm)

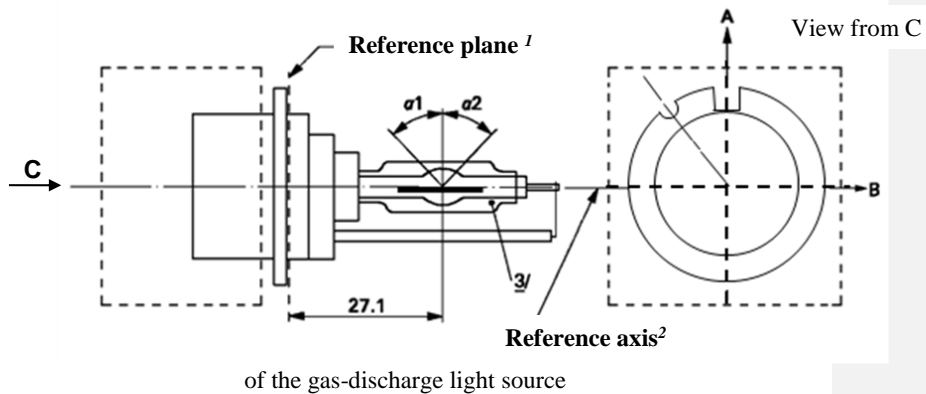

Figure 1
Category D8R - Cap PK32d-8

- ¹ The reference plane is defined by the positions on the surface of the holder on which the three supporting bosses of the cap ring will rest.
- ² See sheet D8R/2.
- ³ When measured at a distance of 27.1mm from the reference plane and with respect to the mid-point of the inner bulb, the outer bulb shall have an eccentricity of 1 mm max.

The cap shall be pushed in this direction

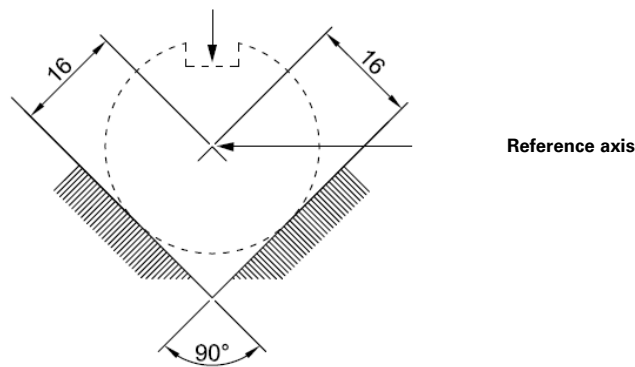

Figure 2
Definition of reference axis¹

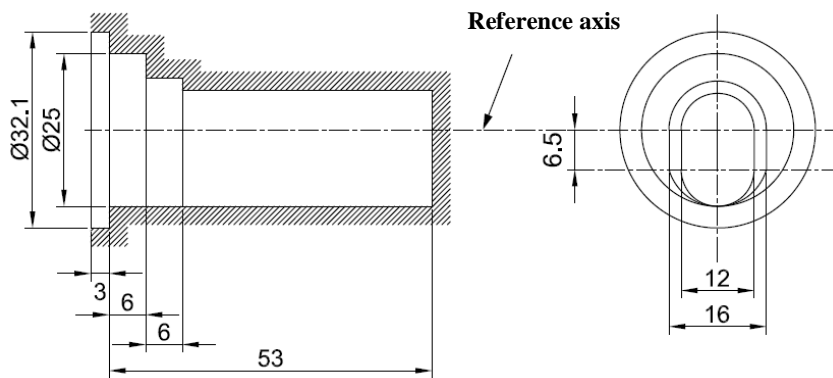

Figure 3
Maximum lamp outline²

1. The reference axis is perpendicular to the reference plane and crosses the intersection of the two parallel lines as indicated in figure 2.
2. Glass bulb and supports shall not exceed the envelope, as indicated in figure

Draft AIS-034 (Part 2) (Rev.3) :2022/D1
June 2023

Category D8R

Sheet D8R/3

<i>Dimensions</i>		<i>Production light sources</i>	<i>Standard light sources</i>	
Position of the electrodes		Sheet D8R/4		
Position and form of the arc		Sheet D8R/5		
α_1^1		55° min.		
α_2^1		55° min.		
D8R: Cap PK32d-8 in accordance with IEC Publication 60061(sheet 7004-111-5)				
Electrical and photometric characteristics				
Rated voltage of the ballast	V	12 ²	12	
Rated wattage	W	25	25	
Test voltage	V	13.2	13.2	
Objective lamp voltage	V	42 ± 9	42 ± 4	
Objective lamp wattage	W	25 ± 3	25 ± 0.5	
Objective Luminous flux	lm	1900 ± 300	1900 ± 100	
Chromaticity coordinates	Objective	x = 0.375	y = 0.375	
	Tolerance area ³	Boundaries	x = 0.345	y = 0.150 + 0.640 x
			x = 0.405	y = 0.050 + 0.750 x
		Intersection points	x = 0.345	y = 0.371
			x = 0.405	y = 0.409
			x = 0.405	y = 0.354
	x = 0.345	y = 0.309		
Hot-restrike switch-off time	s	10	10	

¹ The part of the bulb within the angles α_1 and α_2 shall be the light emitting part. This part shall be as homogeneous in form as possible and shall be optically distortion free. This applies to the whole bulb circumference within the angles α_1 and α_2 except for the black stripes.

² Application voltages of ballasts may differ from 12 V.

³ See Annex D.

Position of the electrodes

This test is used to determine whether the electrodes are correctly positioned relative to the reference axis and the reference plane.

Top view (schematic):

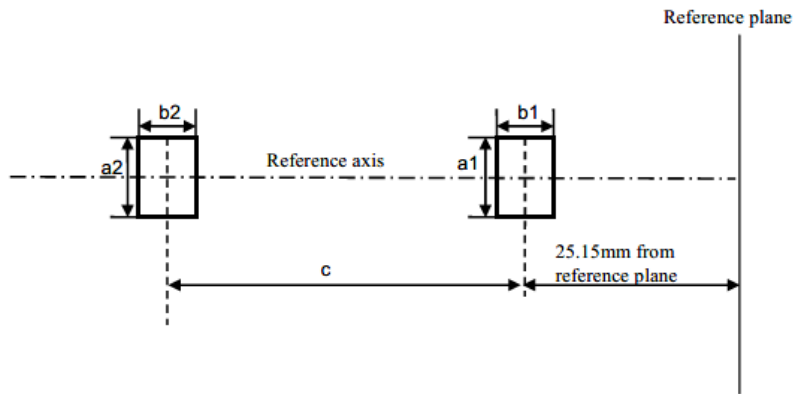

Side view (schematic):

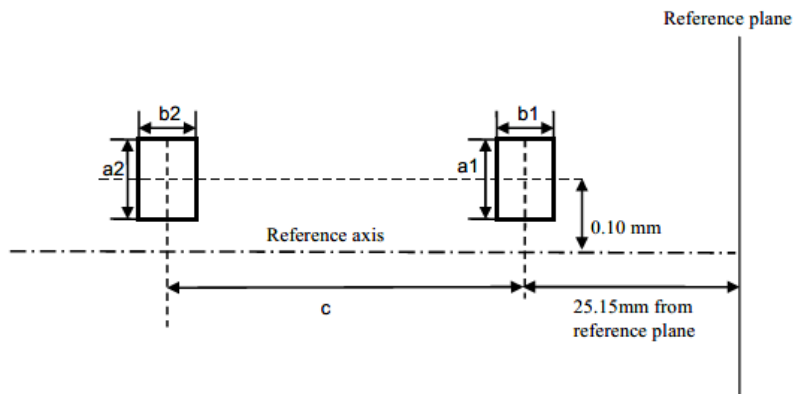

Measuring direction: light source side and top view

<i>Dimension In mm</i>	<i>Production Light sources</i>	<i>Standard Light sources</i>
a1	0.50	0.20
a2	0.70	0.35
b1	0.40	0.15
b2	0.80	0.30
c	3.90	3.90

The arc attachment point to the electrode nearest to the reference plane shall be positioned in the area defined by a1 and b1. The arc attachment point to the electrode furthest from the reference plane shall be positioned in the area defined by a2 and b2.

Position and form of the arc

This test is used to determine the form of the arc and its position relative to the reference axis and the reference plane by measuring its bending and diffusion in the cross section at a distance 27.1 mm from the reference plane.

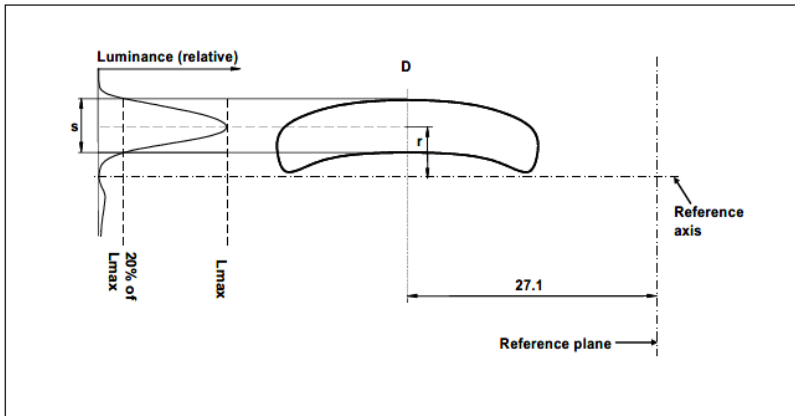

Relative luminance distribution in the central cross section D. The form of the arc is for illustration purpose only. Measuring direction: light source side view

When measuring the relative luminance distribution in the central cross section as indicated in the drawing above, the maximum value shall be located within the distance r from the reference axis. The point of 20 per cent of the maximum value shall be within s .

<i>Dimension In mm</i>	<i>Production Light sources</i>	<i>Standard Light sources</i>
r (arc bending)	0.50 +/- 0.25	0.50 +/- 0.15
s (arc diffusion)	0.70 +/- 0.25	0.70 +/- 0.15

Draft AIS-034 (Part 2) (Rev.3) :2022/D1
June 2023

Category D8R

Sheet D8R/6

Position of the black stripes

This test is used to determine whether the black stripes are correctly positioned relative to the reference axis and the reference plane

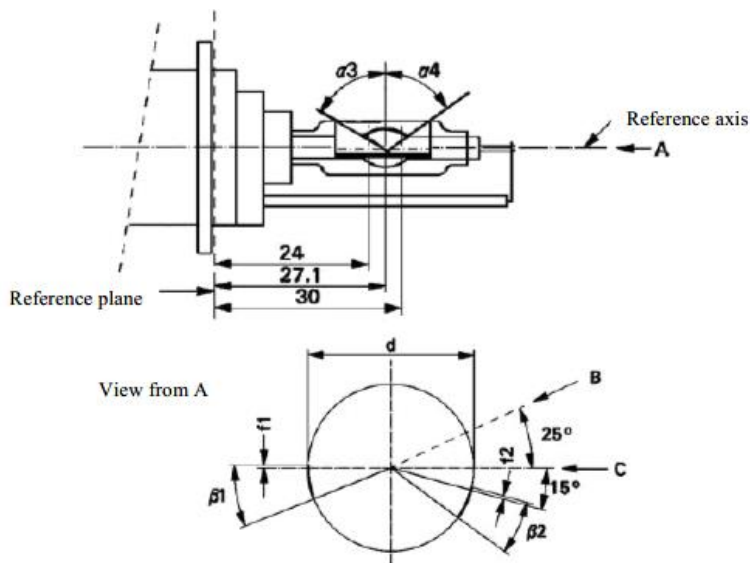

When measuring the luminance distribution of the arc in the central cross section as defined on sheet D8R/5, after having turned the light source so that the black stripe is covering the arc, the measured luminance shall be $\leq 0.5\%$ of L_{max} .

Dimensions	Production light sources	Standard light sources
$\alpha 3$	70° min.	
$\alpha 4$	65° min.	
$\beta 1/24, \beta 1/30, \beta 2/24, \beta 2/30$	25° ± 5°	
$f1/24, f2/24$ ^{1/}	0 ± 0.25	0 ± 0.20
$f1/30$ ^{1/}	$f1/24 \text{ mv} \pm 0.15$ ^{2/}	$f1/24 \text{ mv} \pm 0.1$
$f2/30$ ^{1/}	$f2/24 \text{ mv} \pm 0.15$ ^{2/}	$f2/24 \text{ mv} \pm 0.1$
$f1/24 \text{ mv} - f2/24 \text{ mv}$	± 0.3 max.	± 0.2 max.
d	9 ± 1	

^{1/} "f1/.." means dimension f1 to be measured at the distance from the reference plane indicated in mm after the stroke.

^{2/} " .. /24 mv" means the value measured at a distance of 24 mm from the reference plane

The drawings are intended only to illustrate the essential dimensions (in mm)

Figure 1
Category D9S - Cap PK32d-9

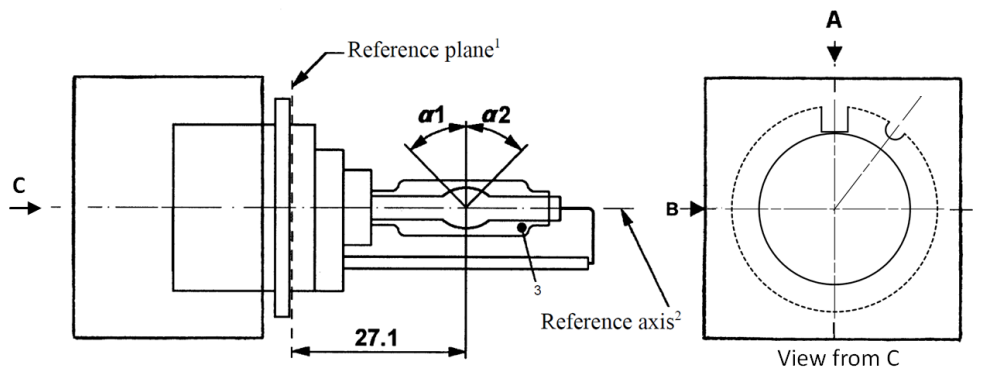

- ¹ The reference plane is defined by the positions on the surface of the holder on which the three supporting bosses of the cap ring will rest.
- ² See sheet D9S/2.
- ³ When measured at a distance of 27.1mm from the reference plane and with respect to the mid-point of the inner bulb, the outer bulb shall have an eccentricity of 1 mm max.

Figure 2
Definition of reference axis¹

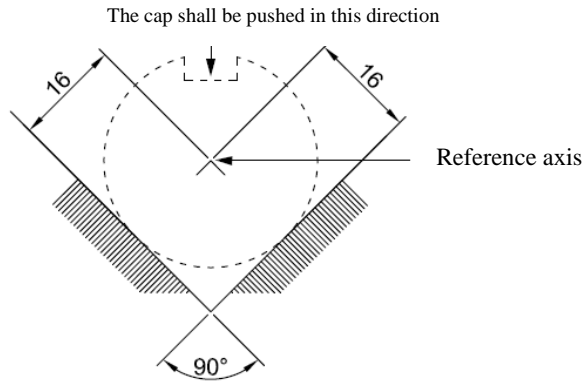
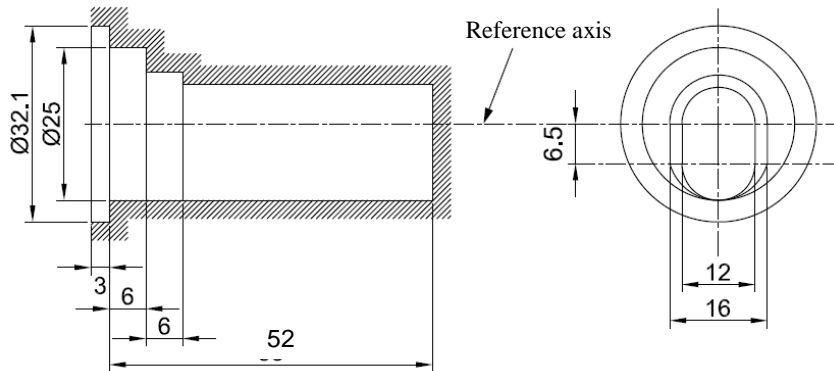

Figure 3
Maximum lamp outline²



- ¹ The reference axis is perpendicular to the reference plane and crosses the intersection of the two parallel lines as indicated in Figure 2.
- ² Glass bulb and supports shall not exceed the envelope, as indicated in Figure 3. The envelope is concentric with the reference axis.

Draft AIS-034 (Part 2) (Rev.3) :2022/D1
June 2023

Category D9S

Sheet D9S/3

<i>Dimensions</i>		<i>Production light sources</i>		<i>Standard light sources</i>		
Position of the electrodes		Sheet D9S/4				
Position and form of the arc		Sheet D9S/5				
α_1, α_2 ¹		55° min.		55° min.		
D9S: Cap PK32d-9 in accordance with IEC Publication 60061 (sheet 7004-111-5)						
Electrical and photometric characteristics						
Rated voltage of the ballast	V	12 ²		12		
Rated wattage	W	27	35	27	35	
Test voltage	V	13.5		13.5		
Objective lamp voltage	V	34 ± 6	38 ± 8	34 ± 4	38 ± 4	
Objective lamp wattage	W	27 ± 3	35 ± 3	27 ± 0.5	35 ± 0.5	
Objective Luminous flux	lm	2000 ± 300	3000 ± 450	2000 ± 100	3000 ± 150	
Chromaticity coordinates	Objective	x = 0.375		y = 0.375		
	Tolerance area ³	Boundaries	x = 0.345		y = 0.150 + 0.640 x	
			x = 0.405		y = 0.050 + 0.750 x	
		Intersection points	x = 0.345		y = 0.371	
			x = 0.405		y = 0.409	
			x = 0.405		y = 0.354	
x = 0.345		y = 0.309				
Hot-restrike switch-off time	s	10		10		

¹ The part of the bulb within the angles α_1 and α_2 shall be the light emitting part. This part shall be as homogeneous in form as possible and shall be optically distortion free. This applies to the whole bulb circumference within the angles α_1 and α_2 .

² Application voltages of ballasts may differ from 12 V.

³ See Annex D.

Position of the electrodes

This test is used to determine whether the electrodes are correctly positioned relative to the reference axis and the reference plane.

Side and top view (schematic):

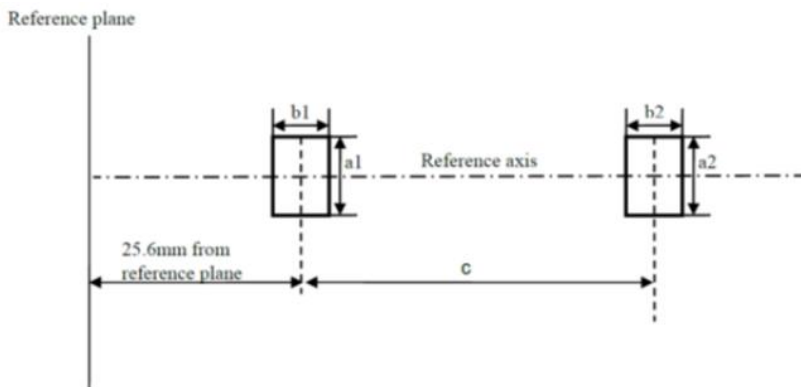

Measuring direction: light source side and top view

<i>Dimension In mm</i>	<i>Production Light sources</i>	<i>Standard Light sources</i>
a1	0.30	0.20
a2	0.50	0.25
b1	0.30	0.15
b2	0.60	0.30
c	3.00	3.00

The arc attachment point to the electrode nearest to the reference plane shall be positioned in the area defined by a1 and b1. The arc attachment point to the electrode furthest from the reference plane shall be positioned in the area defined by a2 and b2. The geometrical data is valid for 27W and 35W operation.

Position and form of the arc

This test is used to determine the form of the arc and its position relative to the reference axis and the reference plane by measuring its bending and diffusion in the cross section at a distance 27.1 mm from the reference plane.

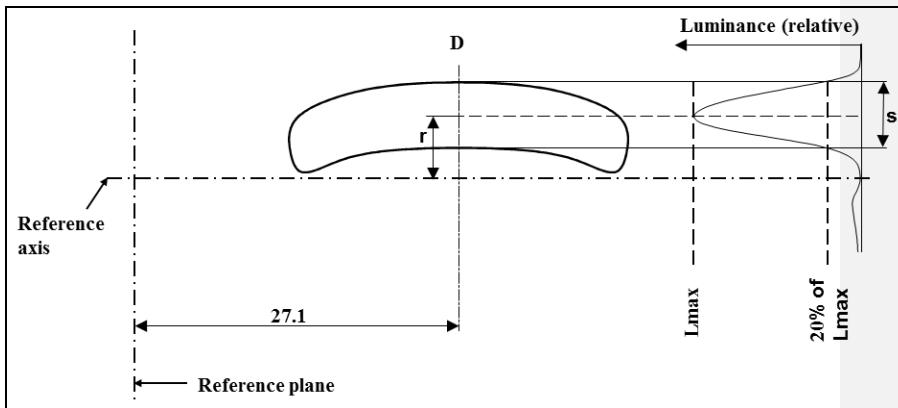

Relative luminance distribution in the central cross section D.	The form of the arc is for illustration purpose only.	Measuring direction: light source side view
---	---	---

When measuring the relative luminance distribution in the central cross section as indicated in the drawing above, the maximum value shall be located within the distance r from the reference axis. The point of 20 per cent of the maximum value shall be within s. The geometrical data is valid for 27W and 35W operation.

Dimension in mm	Production light sources	Standard light sources
r (arc bending)	0.35 +/- 0.25	0.35 +/- 0.15
s (arc diffusion)	0.80 +/- 0.25	0.80 +/- 0.15

ANNEX B

(See clause 2.2.1)

**INFORMATION TO BE SUBMITTED AT THE TIME OF
APPLICATION FOR TYPE APPROVAL**

- 1** Trade name or mark (see note 1 below) of the gas discharge light source:
- 2** Manufacturer's name for the type of gas discharge light source:
- 3** Manufacturer's name and address:
- 4** If applicable, name and address of manufacturer's representative:
- 5** Brand and type number of the ballast
- 6.1** Drawings in triplicate, sufficiently detailed to permit identification of the type and a brief technical description including
- 6.2** Category of Gas discharge light source:
- 6.3** Rated voltage:
- 6.4** Rated wattage:
- 6.5** Position of the approval mark:
- 6.6** Reason(s) for extension (if applicable):
- 6.7.** A technical description including ballast identification

Note 1: See clause 2.2.3 for cases where there is a change in the trade mark.

ANNEX C (Reserved)

ANNEX D

(See clause 3.4.1.)

**METHOD OF MEASUREMENT OF ELECTRICAL AND
PHOTOMETRIC CHARACTERISTICS**

D-1. General

For starting, run-up and hot-restrike tests and for the measurement of electrical and photometric characteristics, the gas-discharge light source shall be operated in free air with an ambient temperature of $25^{\circ} \pm 5^{\circ}$ C.

D-2. Ballast

In the case the ballast is not integrated with the light source, all tests and measurements shall be carried out with the ballast as per clause 2.2.2.4. of this standard. The power supply used for the starting and run-up tests shall be qualified to secure the quick rise of the high current pulse.

D-3. Burning position

The burning position shall be horizontal within $\pm 10^{\circ}$ with the lead wire down. Ageing and testing positions shall be identical. If the gas-discharge light source is accidentally operated in the wrong direction, it shall be re-aged before measurements begin. During ageing and measurements no electrically conducting objects shall be allowed within a cylinder having a diameter of 32 mm and a length of 60 mm concentric with the reference axis and symmetric to the arc. Moreover stray magnetic fields shall be avoided.

D-4. Ageing

All tests shall be carried out with light sources which have been aged for a minimum of 15 cycles having the following switching cycle:

45 minutes on, 15 seconds off, 5 minutes on, 10 minutes off.

D-5. Supply voltage

All tests shall be carried out at test voltage as indicated on the relevant data sheet.

D-6. Starting test

The starting test shall be applied to light sources which have not been aged and have not been used for a period of at least 24 hours prior to the test.

D-7. Run-up test

The run-up test shall be applied to light sources which have not been used for a period of at least 1 hour prior to the test.

D-8. Hot restrike test

The light source shall be started and be operated with the ballast (possibly integrated) at test voltage for a period of 15 minutes. Then the supply voltage to the ballast or the light source with the ballast integrated shall be switched off for a switch-off period as indicated on the relevant data sheet and be switched on again.

D-9. Electrical and photometric test

Before any measurement, the light source shall be stabilized for a period of 15 minutes.

D-10. Colour

The colour of the light source shall be measured in an integrating sphere using a measuring system which shows the CIE chromaticity co-ordinates of the received light with a resolution of ± 0.002 .

ANNEX E
(See clause 3.5.1.)

OPTICAL SET-UP FOR THE MEASUREMENT OF THE POSITION AND FORM OF THE ARC AND OF THE POSITION OF THE ELECTRODES ^{1/}

(^{1/} This method is an example of a measurement method: any method with equivalent measurement accuracy may be used.)

The gas-discharge light source shall be positioned as shown in the main drawing of the respective category.

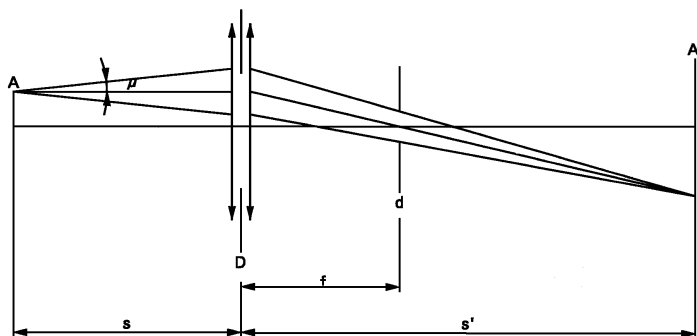

An optical system shall project a real image A' of the arc A with a magnification of preferably $M = s'/s = 20$ on a screen. The optical system shall be aplanatic and achromatic. In the focus-length f of the optical system a diaphragm d shall cause a projection of the arc with nearly parallel observation directions. To get the angle of the half divergence not larger than $\mu=0.5^\circ$, the diameter of the focus-diaphragm with respect to the focus-length of the optical system shall be not more than $d = 2f \tan(\mu)$. The active diameter of the optical system shall

be not more than:

$D = (1 + 1/M)d + c + (b1 + b2)/2$. (c , $b1$ and $b2$ are given in the sheets prescribing the position of the electrodes).

A scale on the screen shall enable to measure the position of the electrodes. The calibration of the arrangement advantageously can be done by using a separate projector with a parallel beam in connection with a gauge whose shadow is projected to the screen. The gauge shall show the reference axis and the plane parallel to the reference plane and at distance "e" mm from it.

Draft AIS-034 (Part 2) (Rev.3) :2022/D1
June 2023

In the plane of the screen a receiver has to be mounted movable in a vertical direction on a line corresponding to the plane at "e" from the reference plane of the gas discharge light source.

The receiver shall have the relative spectral sensitivity of the human eye. The size of the receiver shall be not more than $0.2 M$ mm in the horizontal and not more than $0.025 M$ mm in the vertical direction (M = the magnification). The range of measurable movement shall be such that the required measures of the arc bending r and arc diffusion s can be measured.

For the measurement of the stray light, the size of the receiver shall be circular with a diameter of $0.2M$ mm diameter.

ANNEX F
(See clause 4.2.)

**MINIMUM REQUIREMENTS FOR QUALITY CONTROL
PROCEDURES BY THE MANUFACTURER**

F-1. General

The conformity requirements shall be considered satisfied from a photometric (including UV-radiation), geometrical, visual and electrical standpoint if the specified tolerances for production gas-discharge light sources in the relevant data sheet of Annex A and the relevant data sheet for the caps are met.

F-2. Minimum requirements for verification of conformity by the manufacturer

For each type of gas-discharge light source the manufacturer or the holder of the approval mark shall carry out tests, in accordance with the provisions of this standard, at appropriate intervals.

F-2.1. Nature of tests

Tests of conformity of these specifications shall cover their photometric, geometrical and optical characteristics.

F-2.2. Methods used in tests

F-2.2.1. Tests shall generally be carried out in accordance with the methods set out in this standard.

F-2.2.2. The application of clause 2.2.1. of this annex requires regular calibration of test apparatus and its correlation with measurements made by a testing agency.

F-2.3. Nature of sampling

Samples of gas-discharge light sources shall be selected at random from the production of a uniform batch. A uniform batch means a set of gas-discharge light sources of the same type, defined according to the production methods of the manufacturer.

F-2.4. Inspected and recorded characteristics

The gas-discharge light sources shall be inspected and test results recorded following the grouping of characteristics as listed in Annex G, table G-1.

F-2.5. Criteria governing acceptability

The manufacturer or the holder of approval is responsible for carrying out a statistical study of the test results in order to meet the specification laid down for verification of conformity of products in clause 4.1. of this standard.

Compliance shall be assured if the level of acceptable non-compliance per grouping of characteristics given in table G-1 of Annex G is not exceeded. This means that the number of gas-discharge light sources not complying with the requirement for any grouping of characteristics of any gas-discharge light source type does not exceed the qualifying limits in the relevant tables G-2, G-3 or G- 4 of Annex G.

Note: Each individual gas-discharge light source requirement shall be considered as a characteristic.

ANNEX G

(See F-2.4.)

**SAMPLING AND COMPLIANCE LEVELS FOR
MANUFACTURER'S TEST RECORDS**

Table G-1 - Characteristics

Grouping of characteristics	Grouping ^{*/} of test records between gas-discharge light source types	Minimum 12 monthly sample per grouping ^{*/}	Acceptable level of non-compliance per grouping of characteristics (%)
Marking, legibility and durability	All types with the same external dimensions	315	1
Bulb quality	All types with the same bulb	315	1
External dimensions (excluding cap)	All types of the same category	315	1
Position and dimensions of arc and stripes	All types of the same category	200	6.5
Starting, run-up and hot-restrike	All types of the same category	200	1
Gas-discharge light source voltage and wattage	All types of the same category	200	1
Luminous flux, colour and UV radiation	All types of the same category	200	1

^{*/} The assessment shall in general cover series production gas-discharge light sources from individual factories. A manufacturer may group together records concerning the same type from several factories, provided these operate under the same quality system and quality management.

Draft AIS-034 (Part 2) (Rev.3) :2022/D1
June 2023

Qualifying limits for acceptance based on different numbers of test results for each grouping of characteristics are listed in table G-2 as maximum number of non-compliances. The limits are based on an acceptable level of 1 per cent of non-compliances, assuming an acceptance probability of at least 0.95.

Table G-2

Number of test results of each characteristics	Qualifying limits for acceptance
- 200	5
201 - 260	6
261 - 315	7
316 - 370	8
371 - 435	9
436 - 500	10
501 - 570	11
571 - 645	12
646 - 720	13
721 - 800	14
801 - 860	15
861 - 920	16
921 - 990	17
991 - 1060	18
1061 - 1125	19
1126 - 1190	20
1191 - 1249	21

Draft AIS-034 (Part 2) (Rev.3) :2022/D1
June 2023

Qualifying limits for acceptance based on different numbers of test results for each grouping of characteristics are listed in table G-3 given as maximum number of non-compliances. The limits are based on an acceptable level of 6.5 per cent of non-compliances, assuming an acceptance probability of at least 0.95.

Table G-3

Number of Gas-discharge light source in records	Qualifying limit	Number of Gas-discharge light source in records	Qualifying limit	Number of Gas-discharge light source in records	Qualifying limit
- 200	21	541 - 553	47	894 - 907	73
201 - 213	22	554 - 567	48	908 - 920	74
214 - 227	23	568 - 580	49	921 - 934	75
228 - 240	24	581 - 594	50	935 - 948	76
241 - 254	25	595 - 608	51	949 - 961	77
255 - 268	26	609 - 621	52	962 - 975	78
269 - 281	27	622 - 635	53	976 - 988	79
282 - 295	28	636 - 648	54	989 - 1002	80
296 - 308	29	649 - 662	55	1003 -1016	81
309 - 322	30	663 - 676	56	1017 - 1029	82
323 - 336	31	677 - 689	57	1030 - 1043	83
337 - 349	32	690 - 703	58	1044 - 1056	84
350 - 363	33	704 - 716	59	1057 - 1070	85
364 - 376	34	717 - 730	60	1071 - 1084	86
377 - 390	35	731 - 744	61	1085 - 1097	87
391 - 404	36	745 - 757	62	1098 - 1111	88
405 - 417	37	758 - 771	63	1112 - 1124	89
418 - 431	38	772 - 784	64	1125 - 1138	90
432 - 444	39	785 - 798	65	1139 - 1152	91
445 - 458	40	799 - 812	66	1153 - 1165	92
459 - 472	41	813 - 825	67	1166 - 1179	93
473 - 485	42	826 - 839	68	1180 - 1192	94
486 - 499	43	840 - 852	69	1193 - 1206	95
500 - 512	44	853 - 866	70	1207 - 1220	96
513 - 526	45	867 - 880	71	1221 - 1233	97
527 - 540	46	881 - 893	72	1234 - 1249	98

Draft AIS-034 (Part 2) (Rev.3) :2022/D1
June 2023

Qualifying limits for acceptance based on different numbers of test results for each grouping of characteristics are listed in table G-4 given as a percentage of the results, assuming an acceptance probability of at least 0.95.

Table G-4

Number of test results of each characteristic	Qualifying limits shown as a percentage of results. Acceptable level of 1 per cent of non-compliances	Qualifying limits shown as a percentage of results. Acceptable level of 6.5 per cent of non-compliances
1 250	1.68	7.91
2 000	1.52	7.61
4 000	1.37	7.29
6 000	1.30	7.15
8 000	1.26	7.06
10 000	1.23	7.00
20 000	1.16	6.85
40 000	1.12	6.75
80 000	1.09	6.68
100 000	1.08	6.65
1 000 000	1.02	6.55

ANNEX H

(See clause 4.4.)

**MINIMUM REQUIREMENTS FOR SAMPLING BY
TESTING AGENCY**

- H-1.** The conformity requirements shall be considered satisfied from a photometric, geometrical, visual and electrical standpoint if the specified tolerances for production gas-discharge light sources in the relevant data sheet of Annex A and the relevant data sheet for the caps are met.
- H-2.** The conformity of mass-produced gas-discharge light sources shall not be contested if the results are in agreement with H-5 of this annex.
- H-3.** Conformity shall be contested and the manufacturer requested to make the production meet the requirements if the results are not in agreement with H-5 of this annex.
- H-4.** If H-3 of this annex is applied, a further sample of 250 gas-discharge light sources, selected at random from a recent production run, shall be taken within two months.
- H-5.** Compliance approved or disapproved shall be decided according to the values in table H-1. For each grouping of characteristics gas-discharge light sources shall be either accepted or rejected according to the values in table H-1 ^{*/}.

Table H-1

Sample	1 per cent ^{**/}		6.5 per cent ^{**/}	
	Accept	Reject	Accept	Reject
First sample size: 125	2	5	11	16
If the number of non-conforming units is greater than 2 (11) and less than 5 (16) take a second sample size of 125 and assess the 250	6	7	26	27

^{*/} The proposed scheme is designed to assess the compliance of gas-discharge light sources to an acceptance level of non-compliance of 1 per cent and 6.5 per cent respectively and is based on the Double Sampling Plan for Normal Inspection in IEC Publication 60410: Sampling Plans and Procedures for Inspection by Attributes.

Draft AIS-034 (Part 2) (Rev.3) :2022/D1
June 2023

**/ The gas-discharge light sources shall be inspected and test results recorded following the grouping of characteristics as listed in Annex G, table G-1.

Draft AIS-034 (Part 2) (Rev.3) :2022/D1
June 2023

ANNEX J

(See Introduction)

**COMPOSITION OF AISC PANEL ON
LIGHTING AND LIGHT SIGNALLING DEVICES***

Convener	
Mr. Feroz Ali Khan	SIAM (Hero MotoCorp Ltd.)
Members	Representing
Mr. B. V. Shamsundara	ARAI
Mrs. Jyoti Kirve	ARAI
Mr. Kamallesh Patil	ARAI
Mr. Pratik Nayak	ARAI
Mrs. Vijayanta Ahuja	iCAT
Mr. Mayank Sharma	iCAT
Representative From	CFMTH
Mr. Arvind Kumbhar	SIAM (Bajaj Auto Ltd.)
Mr. Adish Aggarwal	SIAM (Bajaj Auto Ltd.)
Mr. T Vishwanathan	SIAM (Bajaj Auto Ltd.)
Mr. Harjeet Singh	SIAM (Hero MotoCorp Ltd.)
Mr. Subrat Dash	SIAM (Hero MotoCorp Ltd.)
Mr. Varun Sharma	SIAM (Hero MotoCorp Ltd.)
Mr. Prashant Jadhav	SIAM (Hero MotoCorp Ltd.)
Mr. Guru Rajan	SIAM (TVS Motors)
Mr. Ashish Das	SIAM (TVS Motors)
Mr. Pawan Kumar	SIAM (India Yamaha)
Mr. Nikhil Desai	SIAM (Mercedes Benz)
Mr. Faustino V.	SIAM (Ashok Leyland)
Mr. Avinash Khot	SIAM (Suzuki Motorcycle India Pvt. Ltd.)
Mr. P Gowrishankar	SIAM (TATA Motors)

Draft AIS-034 (Part 2) (Rev.3) :2022/D1
June 2023

Ms. Namarata Deb	SIAM (TATA Motors)
Mrs. Pushpanjali Pathak	SIAM (Mahindra & Mahindra)
Mr. E. Shekarbabu	SIAM (Mahindra & Mahindra)
Mrs. Buvaneswari M	SIAM (MSIL)
Mr. Sherekar Utsav Dattatraya	SIAM (MSIL)
Mr. Venusuresh	SIAM (Royal Enfield)
Ms. Aditi Deshpande	SIAM (Skoda India)
Mr. Vipin Sharma	SIAM (Honda Motorcycle & Scooter India)
Mr. Navneet Kaushik	SIAM (Honda Motorcycle & Scooter India)
Mr. Uday Harite	ACMA
Mr. P.N Bhagwan	ACMA (Patodia Glass Ltd.)
Mr. C K Chaudhari	
Mr. Shekhar M. B.	
Ms. Sasikala E	
Mr. Sachin Telore	
Mr. Abhishek Jayamani	
Mr. Anadi Sinha	
Mr. G V George	ACMA (FIEM)
Mr. Maydeo S	ACMA

* At the time of approval of this Automotive Industry Standard (AIS)

Draft AIS-034 (Part 2) (Rev.3) :2022/D1
June 2023

ANNEX K
(See Introduction)

COMMITTEE COMPOSITION *

Automotive Industry Standards Committee

Chairman	To be filled by ARAI
	Director The Automotive Research Association of India, Pune
Members	Representing

Member Secretary

The Automotive Research Association of India, Pune

* At the time of approval of this Automotive Industry Standard (AIS)