

Draft Revision 1

**Approval of Large Passenger Vehicles
with regard to the Strength of their
Superstructure**

Date of Hosting on website: 23rd August 2024

|

**CHECK LIST FOR PREPARING REVISION TO
AUTOMOTIVE INDUSTRY STANDARD (AIS)**

**AIS-031 (Rev. 1) : Approval of Large Passenger Vehicles with regard to the
Strength of their Superstructure**

SR. NO.	PARTICULARS	REMARKS
1	Indicate details of the base reference standard. (e.g. ECE/ EEC directive/GTR, etc...)	UN R 66
1.1	Latest version of the base standard (Sr. No.1) considered for the alignment of this standard.	UN R 66, (02 series of amendments to the Regulation: Date of entry into force: 19 August 2010). This is latest copy of UN R 66 available on UNECE website as on 31 st January 2024.
2	Add an explanatory note indicating differences between the above standard and this standard, if any.	Bus applicability with Seating capacity exceeding 22 passengers is considered as against 16 in UN R 66 and in No technical deviation from base reference. AIS administrative procedures followed are different (refer Annex A of this checklist).
3	Are the details of technical specifications to be submitted at the time of type approval relevant to the requirements of this standard covered?	Yes. Please refer Annex 1 of this standard.
4	Are the performance requirements covered?	Yes
5	Is there a need to specify dimensional requirements? If yes, are they covered?	Yes, covered.
6	Are the details of Criteria for Extension of Type Approval covered?	Yes. (clause 6.0 and Annex 2)
7	Is AIS-037 applicable for the devices covered in this standard, If yes:	No.
7.1	Is there a need to specify COP requirements? If yes, are following covered?	No.
7.2	Tests/checks needed for COP	No.
7.3	Periodicity of COP	No.
7.4	Have the transitional provisions for extension of AIS-037 approval been covered?	No. It is not component standard.
7.5	Has the “type” been defined?	Yes
8.	Is this standard covers the requirements of E/e approved components?	No
9.	Are the provisions for further amendments in ECE regulations addressed?	No.
10.	Is the standard is intended for replacing or revising an already notified standard, if yes:	Yes

SR. NO.	PARTICULARS	REMARKS
10.1	Are the Transitional provisions for re-certification of already certified parts/vehicles by comparing the previous test result, certain additional test, etc. covered?	Yes (Extension criteria of existing standard reproduced in this revision is to be elaborated).
10.2	Can this standard be permitted in lieu of the existing notified standard from the date of adoption of the this standard by CMVR-TSC?	This revision will need separate notification for its establishment.
10.2.1	If so has this been included in the transitional provisions	No, It will be captured through notification
10.3	Have all the transitional provisions been covered?	Transitional provisions are not covered explicitly. However, notified standard AIS-000 and notification for implementation of this revision to be referred for it.
11.	Status of availability of test facilities with approved test agencies?	ARAI, ICAT, CIRT, VRDE
12.	Are there any points on which special comments or information is to be invited from members? If yes, are they identified?	All the points are discussed in AISC and arrived at consensus.
13.	Do components / vehicles manufacturers / Test agencies require lead time to meet requirements of revision?,	Yes
13.1	Recommendation of date for implementation of revision.	From date of final notification.
14.	Is proposed draft notification prepared?	Yes, panel will deliberate and prepare it.
15.	Has the clarity of classification been examined?	Yes
16.	Has the clarity of definitions been examined?	Yes

Annex A to Checklist

(To be elaborated)

The changes from the UN Regulation 66 document and the reason thereof

Clause no. of this standard	Clause no. of UN R 66	Change carried out in this standard	Reason
±	±	Bus applicability with Seating capacity exceeding 22 passengers is considered as against 16 in UN R 66	In line with decision in ±st panel meeting held on 11th August 2023.
	Clauses on approval marking	Reserved	UN R clauses refer to approval marking arrangements, which are not of relevance in India
	--	Clauses related to extension of type approval rephrased as per AIS practice	To follow AIS format
Annex 2	Clause 6	Criteria for extension of approval incorporated	In line with the current AIS-031
		Names of test agencies not included in standard	These are specified in CMVR
		Transitional provisions as appropriate for transition from AIS-031: 2004 to this standard is to be followed, instead of the ECE administrative clauses.	To suit the Indian transitional situation
Annex 2	Clause 6	Criteria of extension of approval is inserted from AIS-031.	ECE approval format not of relevance to India

INTRODUCTION

The Government of India felt the need for a permanent agency to expedite the publication of standards and development of test facilities in parallel when the work on the preparation of the standards is going on, as the development of improved safety critical parts can be undertaken only after the publication of the standard and commissioning of test facilities. To this end, the Ministry of Surface Transport (MOST) has constituted a permanent Automotive Industry Standards Committee (AISC) vide order No.RT-11028/11/97-MVL dated September 15, 1997. The standards prepared by AISC will be approved by the permanent CMVR Technical Standing Committee (CTSC). After approval, the Automotive Research Association of India, (ARAI), Pune, being the Secretariat of the AIS Committee, has published this standard. For better dissemination of this information ARAI may publish this document on their Web site.

The super - structure of the bus shall be so designed and constructed as to eliminate to the greatest possible extent the risk of injury to the occupants in the event of an accident. This standard specifies the requirement of strength of the bus superstructure for the protection of occupants of the bus. This standard forms a part of the Bus Body Code.

In the 70th meeting of AISC held on 13th July 2023, need to upgrade prevailing AIS-031 in line with latest UN Regulation 66.

While preparing revision of this AIS considerable assistance is derived from UN Regulation No. 66: Uniform provisions concerning the approval of Large Passenger Vehicles with regard to the Strength of their Superstructure - (02 series of amendments to the Regulation: Date of entry into force: 19 August 2010).

The AISC panel and Automotive Industry Standards Committee (AISC) responsible for preparation of this standard are given in Annexures.....*(to be included)* respectively.

APPROVAL OF LARGE PASSENGER VEHICLES WITH REGARD TO THE
STRENGTH OF THEIR SUPERSTRUCTURE

CONTENTS

Page

1. Scope
2. Terms and Definitions
3. Application for approval
4. Approval
5. General specifications and requirements ...
6. Modification and extension of approval of a vehicle type

ANNEXES

- Annex 1 - Application for type approval of vehicle with regard to the strength of its superstructure, pursuant to this standard.
- Annex 2 - Criteria for extension of Approval
- Annex 3 - Determination of the centre of gravity of the vehicle
- Annex 4 - Viewpoints on the structural description of the superstructure
- Annex 5 - Rollover test as the basic approval method
- Annex 6 - Rollover test using body sections as an equivalent approval method
- Annex 7 - Quasi-static loading test of body sections as an equivalent approval method
Appendix 1 – Determination of the vertical movement of the centre of gravity during rollover
- Annex 8 - Quasi-static calculation based on testing of components as an equivalent approval method
Appendix 1 – Characteristics of plastic hinges
- Annex 9 - Computer simulation of rollover test on complete vehicle as an equivalent approval method

1. SCOPE

- 1.1. This standard applies to single-deck rigid or articulated vehicles belonging to categories M₂ or M₃, Types II or III having more than ~~22~~ **16** passengers.
- 1.2. At the request of the manufacturer, this standard may also apply to any other M₂ or M₃ vehicle that is not included in paragraph 1.1.
- 1.3. This standard may also be applicable to double-deck buses of categories Type II and Type III at the discretion of the manufacturer.”

2. TERMS AND DEFINITIONS

For the purposes of this standard, the following terms and definitions are used:

2.1. Units of measurement

The units of measurement shall be:

Dimensions and linear distances (mm)	metres (m) or millimetres
Mass or load	kilograms (kg)
Force (and weight)	Newtons (N)
Moment	Newton-metres (Nm)
Energy	Joules (J)
Gravitational constant	9.81 (m/s ²)

- 2.2. "Vehicle" means a bus or coach designed and equipped for transportation of passengers. The vehicle is an individual representative of a vehicle type.
- 2.3. "Vehicle type" means a category of vehicles produced with the same design technical specification, main dimensions and constructional arrangement. The vehicle type shall be defined by the vehicle manufacturer.
- 2.4. "Group of vehicle types" means those vehicle types, proposed in future as well as existing now, which are covered by the approval of the worst case, in respect of this standard.
- 2.5. “Double deck vehicle” means a vehicle where the provided spaces for passengers are arranged, at least in one part, in two superimposed levels and spaces for standing passengers are not provided in the upper deck.”
- 2.6. "Worst case" means the vehicle type, among a group of vehicle types, least likely to withstand the requirements of this standard in respect of the

strength of superstructure. The three parameters which define the worst case are: structural strength, reference energy and the residual space.

- 2.7. "Approval of a vehicle type" means the whole official process in which the vehicle type is checked and tested to prove that it meets all the requirements specified in this standard.
- 2.8. "Extension of approval" means the official process in which a modified vehicle type is approved on the basis of an earlier approved vehicle type, by comparison of structure, potential energy and residual space criteria.
- 2.9. "Articulated vehicle" means a vehicle which consists of two or more rigid sections which articulate to one another, the passenger compartments of each section intercommunicate so that passengers can move freely between them; the rigid sections are permanently connected so that they can only be separated by an operation involving facilities which are normally only found in a workshop.
- 2.10. "Passenger compartment(s)" means the space(s) intended for passengers' use excluding any space occupied by fixed appliances such as bars, kitchenettes or toilets.
- 2.11. "Driver's compartment" means the space intended for the driver's exclusive use and containing the driver's seat, the steering wheel, controls, instruments and other devices necessary for driving the vehicle.
- 2.12. "Occupant restraint" means any device which connects a passenger, driver or crew member to his seat, during a rollover.
- 2.13. "Vertical longitudinal central plane" (VLCP) means the vertical plane which passes through the mid-points of the front axle track and the rear axle track.
- 2.14. "Residual space" means a space to be preserved in the passengers', crew and driver's compartment(s) to provide better survival possibility for passengers, driver and crew in case of a rollover accident.
- 2.15. "Unladen kerb mass" (M_k) means the mass of the vehicle in running order, unoccupied and unladen but with the addition of 75 kg for the mass of the driver, the mass of fuel corresponding to 90 per cent of the capacity of the fuel tank specified by the manufacturer, and the masses of coolant, lubricant, tools and spare wheel, if any.
- 2.16. "Total occupant mass" (M_m) means the combined mass of any passengers, crew who occupy seats fitted with occupant restraints.
- 2.17. "Total effective vehicle mass" (M_t) means the unladen kerb mass of the vehicle (M_k) combined with the portion ($k = 0.5$), of the total occupant mass (M_m), considered to be rigidly attached to the vehicle.

- 2.18. "Individual occupant mass" (M_{mi}) means the mass of an individual occupant. The value of this mass is 68 kg.
- 2.19. "Reference energy" (E_R) means the potential energy of the vehicle type to be approved, measured in relation to the horizontal lower level of the ditch, at the starting, unstable position of the rollover process.
- 2.20. "Rollover test on a complete vehicle" means a test on a complete, full-scale vehicle to prove the required strength of the superstructure.
- 2.21. "Tilting bench" means a technical device, an arrangement of tilting platform, ditch and concrete ground surface, used in the rollover testing of a complete vehicle or body sections.
- 2.22. "Tilting platform" means a rigid plane which can be rotated around a horizontal axis in order to tilt a complete vehicle or body section.
- 2.23. "Body work" means the complete structure of the vehicle in running order, including all the structural elements which form the passenger compartment(s), driver's compartment, baggage compartment and spaces for the mechanical units and components.
- 2.24. "Superstructure" means the load-bearing components of the bodywork as defined by the manufacturer, containing those coherent parts and elements which contribute to the strength and energy absorbing capability of the bodywork, and preserve the residual space in the rollover test.
- 2.25. "Bay" means a structural section of the superstructure forming a closed loop between two planes which are perpendicular to the vertical longitudinal central plane of the vehicle. A bay contains one window (or door) pillar on each side of the vehicle as well as side wall elements, a section of the roof structure and a section of the floor and underfloor structure.
- 2.26. "Body section" means a structural unit, which represents one part of the superstructure for the purposes of an approval test. A body section contains at least two bays connected by representative connecting elements (side, roof, and underfloor, structures).
- 2.27. "Original body section" means a body section composed of two or more bays of exactly the same form and relative position, as they appear in the actual vehicle. All connecting elements between the bays are also arranged exactly as they appear in the actual vehicle.
- 2.28. "Artificial body section" means a body section built up from two or more bays but not in the same position, nor at the same distance from each other as in the actual vehicle. The connecting elements between these bays need not be identical with the real body work structure but shall be structurally equivalent.

- 2.29. "Rigid part" means a structural part or element which does not have significant deformation and energy absorption during the rollover test.
- 2.30. "Plastic zone" (PZ) means a special geometrically limited part of the superstructure in which, as the result of dynamic, impact forces:
- large scale plastic deformations are concentrated
 - essential distortion of the original shape (cross section, length, or other geometry) occurs
 - loss of stability occurs, as a result of local buckling,
 - kinetic energy is absorbed due to deformation.
- 2.31. "Plastic hinge" (PH) means a simple plastic zone formed on a rod-like element (single tube, window column, etc).
- 2.32. "Cantrail" means the longitudinal structural part of the bodywork above the side windows including the curved transition to the roof structures. In the rollover test the cantrail (in the case of a double deck coach, the cantrail of the upper deck) hits the ground first.
- 2.33. "Waistrail" means the longitudinal structural part of the bodywork below the side windows. In the rollover test the waistrail (in the case of a double deck coach, the waistrail of the upper deck) may be the second area to contact the ground after initial deformation of the vehicle cross-section.

3. APPLICATION FOR APPROVAL

- 3.1. The application for approval of a vehicle type with regard to the strength of its superstructure shall be submitted by the vehicle manufacturer or by his duly accredited representative to the Testing Agency notified under CMV Rule 126.
- 3.2. It shall be accompanied by the undermentioned documents and by the following particulars:
- 3.2.1. The main identifying data and parameters of the vehicle type, or group of vehicle types;
- 3.2.1.1. General layout drawings of the vehicle type, its bodywork and its interior arrangement with the main dimensions. Seats which have passenger restraints shall be clearly marked and their positions in the vehicle shall be accurately dimensioned;
- 3.2.1.2. The unladen kerb mass of the vehicle, and the associated axle loads;
- 3.2.1.3. The exact position of the unladen vehicle's centre of gravity together with the measuring report. To determine the centre of gravity position the measuring and calculation methods described in Annex 3 shall be used;

- 3.2.1.4. The total effective vehicle mass, and the associated axle loads.
- 3.2.1.5. The exact position of the centre of gravity of the total effective mass of the vehicle, together with the measuring report. To determine the centre of gravity position, the measuring and calculation methods described in Annex 3 shall be used.
- 3.2.2. All the data and information which are needed to evaluate the worst case criteria in a group of vehicle types:
 - 3.2.2.1. The value of reference energy (E_R) which is the product of the vehicle mass (M), the gravity constant (g) and the height (h_1) of centre of gravity with the vehicle in its unstable equilibrium position when starting the rollover test (see figure 3)

$$E_R = M.g.h_1 = M.g \left[0.8 + \sqrt{h_0^2 + (B \pm t)^2} \right]$$

where:

- M = M_k , the unladen kerb mass of the vehicle type if there are no occupant restraints, or,
 M_i , total effective vehicle mass when occupant restraints are fitted, and
 $M_i = M_k + k.M_m$, where $k = 0.5$ and M_m is the total mass of the restrained occupants (see paragraph 2.16.).
- h_0 = the height (in metres) of the vehicle centre of gravity for the value of mass (M) chosen
- t = perpendicular distance (in metres) of the vehicle centre of gravity from its longitudinal vertical central plane.
- B = perpendicular distance (in metres) of the vehicle's longitudinal vertical central plane to the axis of rotation in the rollover test
- g = gravitational constant
- h_1 = the height (in metres) of the vehicle centre of gravity in its starting, unstable position related to the horizontal lower plane of the ditch

- 3.2.2.2. Drawings and detailed description of the superstructure of the vehicle type or group of vehicle types according to Annex 4.
- 3.2.2.3. Detailed drawings of the residual space according to paragraph 5.2. for every vehicle type to be approved.
- 3.2.3. Further detailed documentation, parameters, data depending on the approval test method chosen by the manufacturer, as detailed in Annex 5, Annex 6, Annex 7, Annex 8 and Annex 9.

- 3.2.4. In case of an articulated vehicle, all of this information shall be given separately for each section of the vehicle type, except for paragraph 3.2.1.1. which is related to the complete vehicle.
- 3.3. On request of the testing agency a complete vehicle (or one vehicle from each vehicle type, if approval is requested for a group of vehicle types) shall be presented to check its unladen kerb mass, axle loads, position of the centre of gravity and all other data and information which are relevant to the strength of superstructure.
- 3.4. According to the approval test method chosen by the manufacturer, appropriate test pieces shall be submitted to the testing agency upon its request. The arrangement and number of these test pieces shall be agreed with the testing agency. In case of test pieces which have been tested earlier, the test reports shall be submitted.

4. APPROVAL

- 4.1. If the vehicle type or group of vehicle types submitted for approval to this standard meets the requirements of paragraph 5. below, approval of that vehicle type shall be granted.
- 4.2. The application for approval of a vehicle type with regard to the strength of its superstructure shall be submitted by the vehicle/bus body manufacturer to the Test Agency.
- 4.3. It shall be accompanied with the documents details specified in Annex 1 of this standard.

5. GENERAL SPECIFICATIONS AND REQUIREMENTS

5.1. Requirements

The superstructure of the vehicle shall have the sufficient strength to ensure that the residual space during and after the rollover test on complete vehicle is unharmed. That means:

- 5.1.1. No part of the vehicle which is outside the residual space at the start of the test (e.g. pillars, safety rings, luggage racks) shall intrude into the residual space during the test. Any structural parts, which are originally in the residual space (e.g. vertical handholds, partitions, kitchenettes, toilets) shall be ignored when evaluating the intrusion into the residual space.
- 5.1.2. No part of the residual space shall project outside the contour of the deformed structure.

The contour of the deformed structure shall be determined sequentially, between every adjacent window and/or door pillar. Between two deformed pillars the contour shall be a theoretical surface, determined by

straight lines, connecting the inside contour points of the pillars which were the same height above the floor level before the rollover test (see Figure 1).

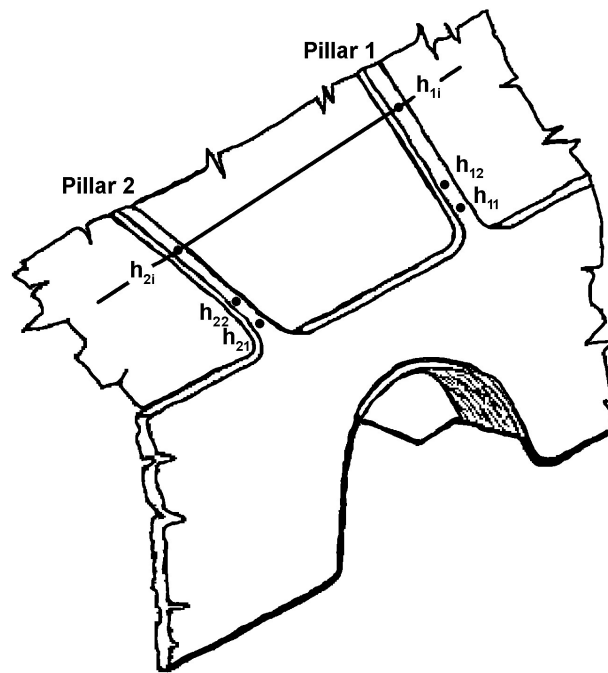

Figure 1 - Specification of the contour of the deformed structure

5.2. Residual space

The envelope of the vehicle's residual space is defined by creating a vertical transverse plane within the vehicle which has the periphery described in Figures 2(a) and 2(c), and moving this plane through the length of the vehicle (see Figure 2(b)) in the following manner:

- 5.2.1. The S_R point is located on the seat-back of each outer forward or rearward facing seat (or assumed seat position), 500 mm above the floor under the passengers' feet/seat (as applicable), 150 mm from the inside surface of the side wall. No account shall be taken of wheel arches and other variations of the floor height. These dimensions shall also be applied in the case of inward facing seats in their centre planes.
- 5.2.2. If the two sides of the vehicle are not symmetrical in respect of floor arrangement and, therefore, the height of the S_R points are different, the step between the two floor lines of the residual space shall be taken as the longitudinal vertical centre plane of the vehicle (see Figure 2(c));
- 5.2.3. The rearmost position of the residual space is a vertical plane 200 mm behind the S_R point of the rearmost outer seat, or the inner face of the rear wall of the vehicle if this is less than 200 mm behind that S_R point.

The foremost position of the residual space is a vertical plane 600 mm in front of the S_R point of the foremost seat (whether passenger, crew, or driver) in the vehicle set at its fully forward adjustment.

If the rearmost and foremost seats on the two sides of the vehicle are not in the same transverse planes, the length of the residual space on each side will be different;

- 5.2.4. The residual space is continuous in the passenger, crew and driver compartment(s) between its rearmost and foremost plane and is defined by moving the defined vertical transverse plane through the length of the vehicle along straight lines through the S_R points on both sides of the vehicle. Behind the rearmost and in front of the foremost seat's S_R point the straight lines are horizontal.
- 5.2.5. The manufacturer may define a bigger residual space than is required for a given seat arrangement, to simulate a worst case in a group of vehicle types to allow for future design development.

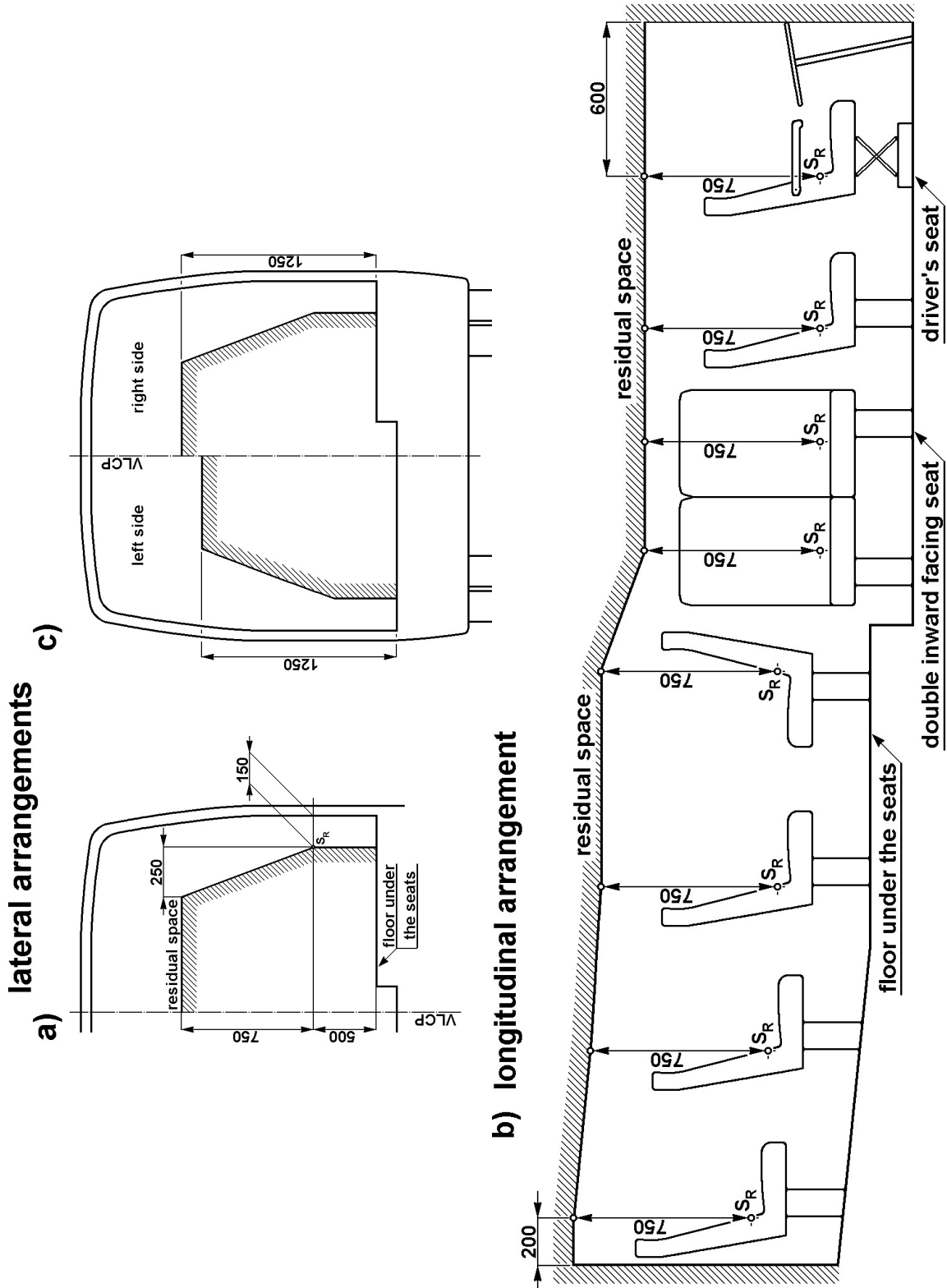

Figure 2 - Specification of residual space

5.3. Specification of rollover test on a complete vehicle as the basic approval method

The rollover test is a lateral tilting test (see Figure 3), specified as follows:

- 5.3.1. The complete vehicle is standing on the tilting platform, with blocked suspension and is tilted slowly to its unstable equilibrium position. If the vehicle type is not fitted with occupant restraints it will be tested at unladen kerb mass. If the vehicle type is fitted with occupant restraints it will be tested at total effective vehicle mass;
- 5.3.2. The rollover test starts in this unstable vehicle position with zero angular velocity and the axis of rotation runs through the wheel-ground contact points. At this moment the vehicle is characterized by the reference energy E_R (see paragraph 3.2.2.1. and Figure 3);
- 5.3.3. The vehicle tips over into a ditch, having a horizontal, dry and smooth concrete ground surface with a nominal depth of 800 mm;
- 5.3.4. The detailed technical specification of the rollover test on a complete vehicle as the basic approval test is given in Annex 5.

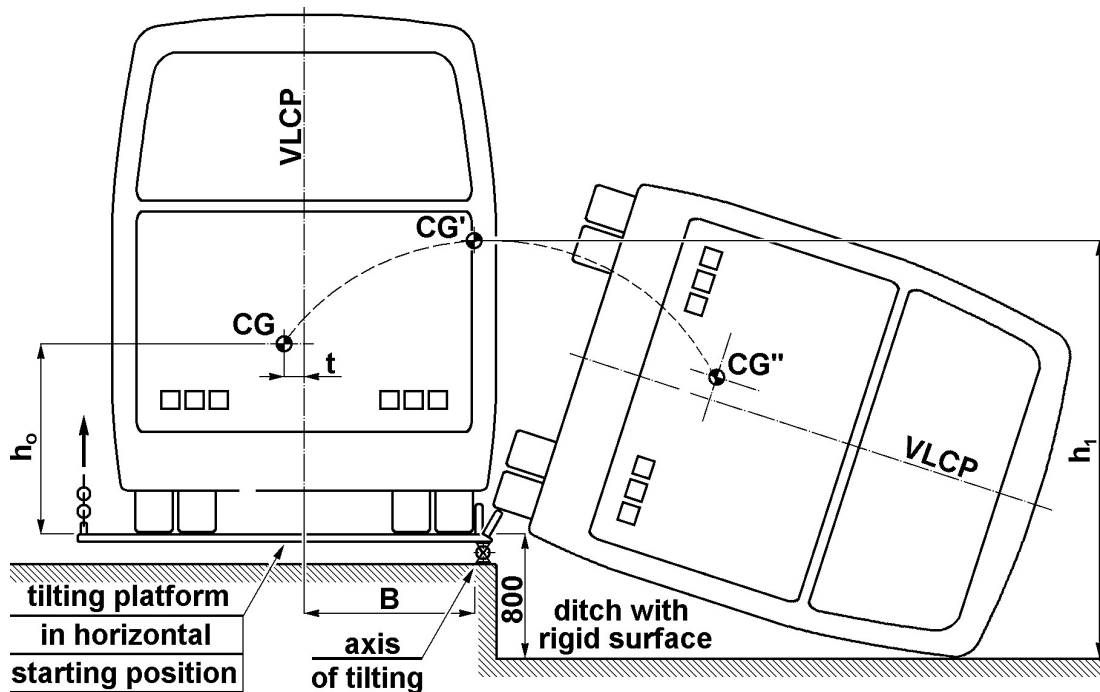

Figure 3 - Specification of the rollover test on a complete vehicle showing the path of the centre of gravity through the starting, unstable equilibrium, position

5.4. Specifications of equivalent approval tests

Instead of the rollover test on a complete vehicle, at the discretion of the manufacturer, one of the following equivalent approval test methods may be chosen:

- 5.4.1. Rollover test on body sections which are representative of the complete vehicle, in accordance with the specifications of Annex 6.
- 5.4.2. Quasi-static loading tests of body sections in accordance with the specifications of Annex 7.
- 5.4.3. Quasi-static calculations based on the results of component tests in accordance with the specifications of annex 8.
- 5.4.4. Computer simulation - via dynamic calculations - of the basic rollover test on a complete vehicle in accordance with the specifications of Annex 9.
- 5.4.5. The basic principle is that the equivalent approval test method must be carried out in such a way that it represents the basic rollover test specified in Annex 5. If the equivalent approval test method chosen by the manufacturer cannot take account of some special feature or construction of the vehicle (e.g. air-conditioning installation on the roof, changing height of the waist rail, changing roof height) the complete vehicle may be required by the testing agency to undergo the rollover test specified in Annex 5.

5.5. Testing of articulated vehicles

In the case of an articulated vehicle, each rigid section of the vehicle shall comply with the general requirement specified in paragraph 5.1. Each rigid section of an articulated vehicle may be tested separately or in combination as described in Annex 5, paragraph 2.3, or in Annex 3, paragraph 2.6.7."

5.6. Direction of rollover test

The rollover test shall be carried out on that side of the vehicle which is more dangerous with respect to the residual space. The decision is made by the testing agency on the basis of the manufacturer's proposal, considering at least the following:

- 5.6.1. the lateral eccentricity of the centre of gravity and its effect on the reference energy in the unstable, starting position of the vehicle, see paragraph 3.2.2.1;
- 5.6.2. the asymmetry of the residual space, see paragraph 5.2.2
- 5.6.3. the different, asymmetrical constructional features of the two sides of the vehicle, and the support given by partitions or inner boxes (e.g. wardrobe, toilet, kitchenette). The side with the lesser support shall be chosen as the direction of the rollover test.

6. MODIFICATION AND EXTENSION OF APPROVAL OF A VEHICLE TYPE
- 6.1. Every modification of the approved vehicle type shall be advised to the testing agency which granted the type approval. The testing agency may then either,
 - 6.1.1. agree that the modifications made are unlikely to have an appreciable effect and that in any case the modified vehicle type still complies with the requirements of this standard and constitutes part of a group of vehicle types together with the approved vehicle type; or
 - 6.1.2. require a further test report from the testing agency responsible for conducting the tests to prove that the new vehicle type complies with the requirements of this standard and constitutes part of a group of vehicle types together with the approved vehicle type; or
 - 6.1.3. refuse the extension of approval and require a new approval procedure to be carried out.
- 6.2. The decisions of the testing agency shall be based on the threefold criteria of the worst case:
 - 6.2.1. the structural criterion means whether the superstructure is changed or not (see Annex 4). If no change, or the new superstructure is stronger, this is favourable.
 - 6.2.2. the energy criterion means whether the reference energy is changed or not. If the new vehicle type has the same or smaller reference energy than the approved one, this is favourable.
 - 6.2.3. residual space criterion is based on the envelope surface of the residual space. If the residual space of the new vehicle type is everywhere within the approved case residual space, this is favourable.
- 6.3. If all three criteria described in paragraph 6.2. are changed favourably, the extension of the approval shall be granted without further investigation.

If all of three answers are unfavourable, a new approval procedure is required.

If the answers are mixed, further investigations (tests, calculation, structural analysis, for example) will be required. These investigations shall be determined by the testing agency cooperating with the manufacturer.

Note: For detailed criteria on extension of approval, please refer Annex 2.
- 6.4. The testing agency issuing the extension of approval shall assign a series number to Technical specification as per Annex 1 drawn up for such an extension.

Annex 1

Information on Technical Specifications to be submitted by the Vehicle Manufacturer

1. Trade name or mark of the vehicle type:
2. Vehicle type¹:
3. Vehicle category ²
4. Manufacturer's name and address:
5. If applicable, name and address of the manufacturer's representative:
6. Brief summary of description of the superstructure in respect of paragraph 3.2.2.2. of this standard and Annex 4 also including its dimensions, configuration and constituent materials and its attachment to any chassis frame:
7. Reference number of detailed drawing showing the residual space used in the approval procedure:
8. Unladen kerb mass (kg): and associated axle loads (kg):
9. Maximum number of seats permitted to be fitted with occupant restraints
10. The position of the centre of gravity of the unladen vehicle in the longitudinal, transverse and vertical planes:
- 10.1. for unladen kerb mass:
- 10.2. for total effective mass:.....
11. If the vehicle is fitted with occupant restraints then additionally, the total effective vehicle mass (kg): and the associated axle loads (kg):
12. The value of reference energy (E_R) as specified in paragraph 3.2.2.1. of this standard: ...
13. Vehicle submitted for approval on:
14. Method of test or calculation employed for approval:
15. Direction of the rollover test used or assumed during the approval procedure:

=====

¹Type II / III as defined in AIS-052(Rev. 1) : 2008, as amended from time to time.

²As defined in IS 14272 : 2011, as amended from time to time.

16. Drawings of the vehicle and those parts of its interior arrangement which have an influence on the strength of the superstructure or on the residual space:
17. The vehicle/bus body manufacturer may either offer a complete vehicle or one or more sections of the superstructure representative of the type to be approved shall be submitted to the Test Agency for conducting the approval tests unless the approval is to be conducted by means of calculation, in which case the calculation shall be submitted to the Test Agency:

Annex 2

CRITERIA FOR EXTENSION OF APPROVAL *

Parameter	Change	Test Required
Roll Over test		
Body mountings on chassis		
i) Number of mountings	i) Decreased	i) Test
ii) Quality of fasteners	ii) Superior quality or equivalent	ii) No test
iii) Position of mountings	iii) Any change	iii) Test
Pillar pitch	i) Increase ii) Decrease	i) Test ii) No test
Number of gussets at joints	Increase	No test
Number of reinforcements	Increase	No test
Cross sectional area of the body structure	Increase	No test
Sheet metal thickness with same material	Increase	No test
Sheet materials	Superior Quality or equivalent	No test
Centre of gravity	Increase more than 10%	Test
Total energy	Increase more than 10%	Test
<p>*Test Agency may re-evaluate the tested model, if there is any change, in parameters which may affect the earlier test results to ascertain the extension of approval.</p>		

Annex 3

DETERMINATION OF THE CENTRE OF GRAVITY OF THE VEHICLE

1. General principles

1.1. The reference and the total energy to be absorbed in the rollover test depend directly on the position of the vehicle's centre of gravity position. Therefore, its determination should be as accurate as practicable. The method of measurement of dimensions, angles and load values, and the accuracy of measurement shall be recorded for assessment by the testing agency. The following accuracy of measuring apparatus is required:

- | | | |
|--|-------------|---------------------|
| - for measurements less than 2000 mm, | accuracy of | ± 1 mm |
| - for measurements greater than 2000 mm, | accuracy of | ± 0.05 per cent |
| - for measured angles, | accuracy of | ± 1 per cent |
| - for measured load values | accuracy of | ± 0.2 per cent |

The wheel-base(s) and the distance between the centres of the footprint of the wheel(s) at each axle (the track of each axle) shall be determined from the manufacturer's drawings.

1.2. Blocked suspension is specified as the condition for determining centre of gravity and for carrying out the actual rollover test. The suspension shall be blocked in the normal operating position as defined by the manufacturer

1.3. The position of the centre of gravity is defined by three parameters:

1.3.1. longitudinal distance (l_1) from the centre line of front axle

1.3.2. transverse distance (t) from the vertical longitudinal central plane of the vehicle.

1.3.3. vertical height (h_0) above the flat horizontal ground level when the tyres are inflated as specified for the vehicle

1.4. A method for determining l_1 , t , h_0 , using load cells is described here. Alternative methods using lifting equipment and/or tilt tables for example may be proposed by the manufacturer to the testing agency who will decide whether the method is acceptable based on its degree of accuracy.

1.5. The centre of gravity position of the unladen vehicle (unladen kerb mass M_k) shall be determined by measurements.

1.6. The centre of gravity position of the vehicle with total effective mass (M_t) may be determined:

1.6.1. by measuring the vehicle in total effective mass condition, or

- 1.6.2. by using the measured centre of gravity position in the unladen kerb mass condition and considering the effect of the total occupant mass.
- 1.6.3. In the case of a double deck vehicle, the mass of the passengers both on the lower and upper deck seats shall be taken into account

2. Measurements

- 2.1. The position of the vehicle's centre of gravity shall be determined in the unladen kerb mass condition or the total effective vehicle mass condition as defined in paragraphs 1.5. and 1.6. For the determination of the position of the centre of gravity in the total effective vehicle mass condition, the individual occupant mass (factored by the constant, $k = 0.5$) shall be positioned and rigidly held 100 mm above and 100 mm forward of the R point of the seat.
- 2.2. The longitudinal (l_1) and transverse (t) coordinates of centre of gravity shall be determined on a common horizontal ground (see Figure A3.1) where each wheel or twinned wheel of the vehicle is standing on an individual load cell. Each steered wheel shall be set to its straight-ahead position.
- 2.3. The individual load-cell readings shall be noted simultaneously and shall be used to calculate the total vehicle mass and centre of gravity position.
- 2.4. The longitudinal position of the centre of gravity relative to the centre of the contact point of the front wheels (see Figure A3.1) is given by,

$$l_1 = \frac{(P_3 + P_4) \cdot L_1 + (P_5 + P_6) \cdot L_2}{(P_{\text{total}})}$$

where:

P_1 = reaction load on the load cell under the left-hand wheel of the first axle

P_2 = reaction load on the load cell under the right-hand wheel of the first axle

P_3 = reaction load on the load cell under the left-hand wheel(s) of the second axle

P_4 = reaction load on the load cell under the right-hand wheel(s) of the second axle

P_5 = reaction load on the load cell under the left-hand wheel(s) of the third axle

P_6 = reaction load on the load cell under the right-hand wheel(s) of the third axle

$P_{\text{total}} = (P_1 + P_2 + P_3 + P_4 + P_5 + P_6) = M_k$ unladen kerb mass; or,

$= M_t$ total effective vehicle mass, as appropriate

L_1 = the distance from centre of wheel on 1st axle to centre of wheel on second axle

L_2 = the distance from centre of wheel on 1st axle to centre of wheel on third axle, if fitted

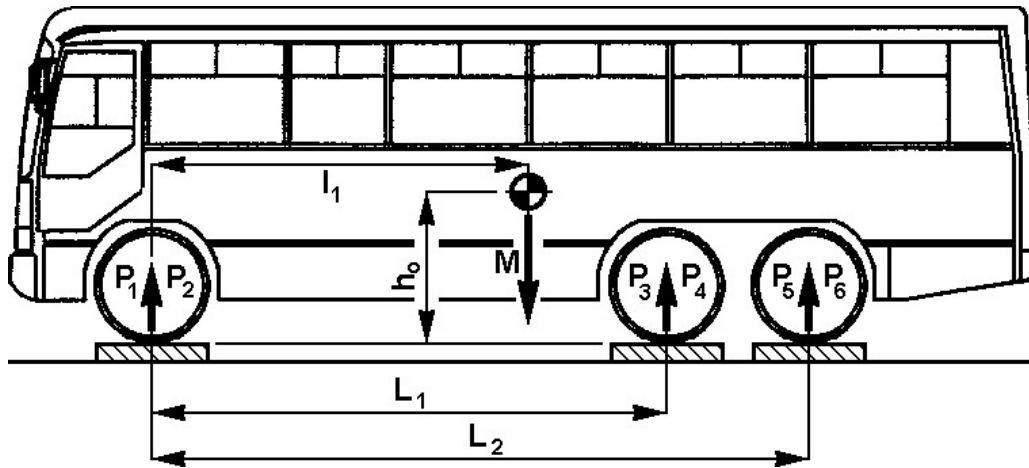

Figure A3.1 - Longitudinal position of the centre of gravity

- 2.5. The transverse position (t) of the vehicle's centre of gravity relative to its longitudinal vertical centre plane (see figure A3.2) is given by,

$$t = \left((P_1 - P_2) \frac{T_1}{2} + (P_3 - P_4) \frac{T_2}{2} + (P_5 - P_6) \frac{T_3}{2} \right) \frac{1}{P_{\text{total}}}$$

where:

- T_1 = distance between the centres of the footprint of the wheel(s) at each end of the first axle
- T_2 = distance between the centres of the footprint of the wheel(s) at each end of the second axle
- T_3 = distance between the centres of the footprint of the wheel(s) at each end of the third axle

This equation assumes that a straight line can be drawn through the centre points of T_1 , T_2 , T_3 . If this is not the case then a specialised formula will be required.

If the value of (t) is negative, then the centre of gravity of the vehicle is situated to the right of the centreline of the vehicle.

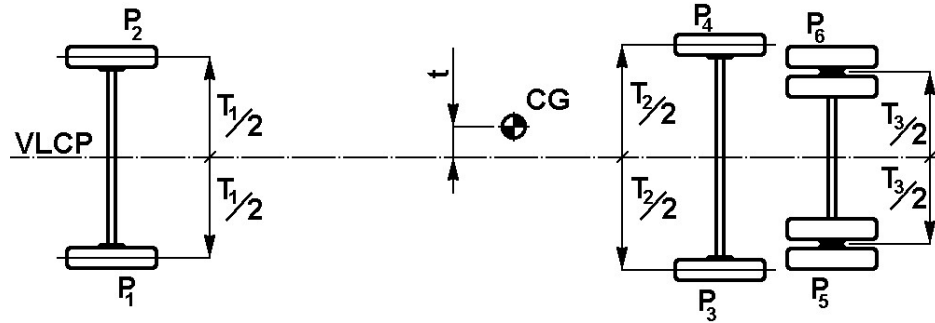

Figure A3.2 - Transverse position of centre of gravity

- 2.6. The height of the centre of gravity (h_0) shall be determined by tilting the vehicle longitudinally and using individual load-cells at the wheels of two axles.
- 2.6.1. Two load-cells shall be positioned on a common horizontal plane, to receive the front wheels. The horizontal plane shall be at sufficient height above the surrounding surfaces that the vehicle can be tilted forward to the required angle (see paragraph 2.6.2. below) without its nose touching that surface.
- 2.6.2. A second pair of load-cells shall be placed in a common horizontal plane on top of support structures, ready to receive the wheels of the second axle of the vehicle. The support structures shall be sufficiently tall to generate a significant angle of inclination α ($> 20^\circ$) for the vehicle. The greater the angle, the more accurate will be the calculation – see figure A3.3. The vehicle is repositioned on the four load-cells, with the front wheels chocked to prevent the vehicle rolling forward. Each steered wheel shall be set to its straight-ahead steer position.
- 2.6.3. The individual load-cell readings shall be noted simultaneously and shall be used to check the total vehicle mass and centre of gravity position.
- 2.6.4. The inclination of the tilting test shell be determined by the equation (see figure A3.3)

$$\alpha = \arcsin\left(\frac{H}{L_1}\right)$$

where:

H = height difference between the footprints of the wheels of the first and second axles
 L₁ = the distance from centre of wheel's first and second axles

- 2.6.5. The unladen kerb mass of the vehicle shall be checked as follows:

$$F_{\text{total}} = F_1 + F_2 + F_3 + F_4 \equiv P_{\text{total}} \equiv M_k$$

where:

- F_1 = reaction load on the load cell under the left hand wheel of the first axle
- F_2 = reaction load on the load cell under the right hand wheel of the first axle
- F_3 = reaction load on the load cell under the left hand wheel of the second axle
- F_4 = reaction load on the load cell under the right hand wheel of the second axle

If this equation is not fulfilled the measurement shall be repeated and/or the manufacturer shall be asked to modify the value of the unladen kerb mass in the technical description of the vehicle.

2.6.6. The height (h_o) of the vehicle centre of gravity is given by:

$$h_o = r + \left(\frac{1}{\text{tg}\alpha} \right) \left(l_1 - L_1 \frac{F_3 + F_4}{P_{\text{total}}} \right)$$

where:

r = height of wheel centre (on first axle) above the load cell top surface

2.6.7. If the articulated vehicle is tested in separate sections, the centre of gravity position shall be established separately for each section.

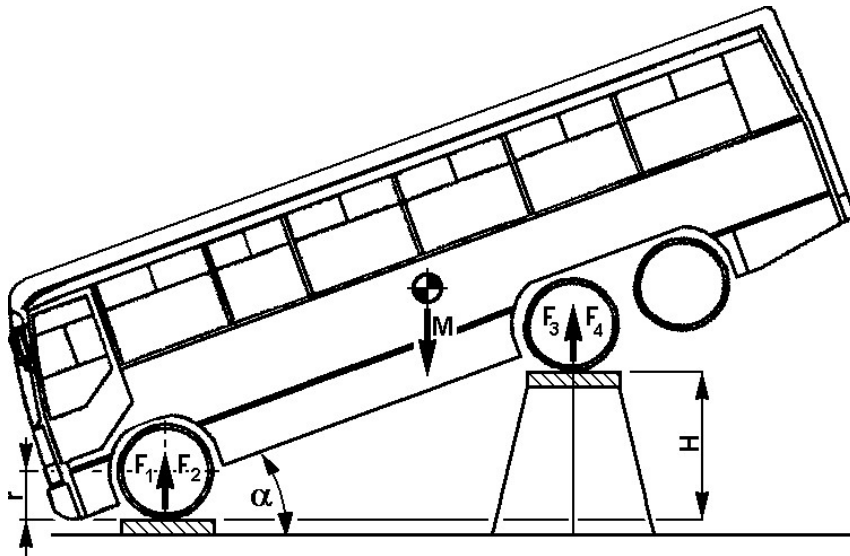

Figure A3.3 - Determination of height of centre of gravity

3. At the request of manufacturer, for determination of height of centre of gravity, alternatively, test procedure defined in IS 11849: 2013 as amended from time to time shall be referred.

Annex 4

VIEWPOINTS ON THE STRUCTURAL DESCRIPTION OF THE SUPERSTRUCTURE

1. General principles

1.1. The manufacturer shall define unambiguously the superstructure of the bodywork (see figure A4.1, for example) and shall state:

1.1.1. which bays contribute to the strength and energy absorption of the superstructure;

1.1.2. which connecting elements between the bays contribute to the torsional stiffness of the superstructure;

1.1.3. the mass distribution among the nominated bays;

1.1.4. which elements of the superstructure are assumed as rigid parts.

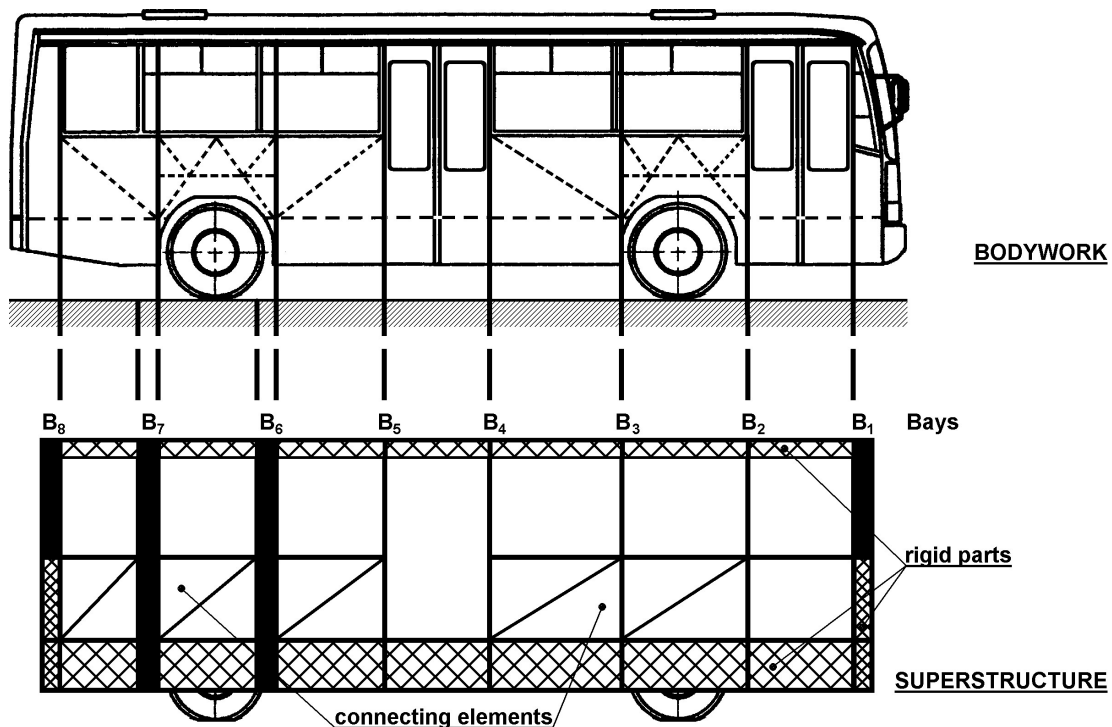

Figure A4. 1 - Derivation of the superstructure from the bodywork

1.2. The manufacturer shall supply the following information about the elements of the superstructure:

1.2.1. drawings, with all the significant geometrical measurements necessary to produce the elements and to evaluate any change or alteration of the element;

- 1.2.2. the material of the elements referred to national, or international standards;
- 1.2.3. the joint technology between the structural elements (riveted, bolted, glued, welded, type of welding, etc.).
- 1.3. Every superstructure shall have at least two bays: one in front of the centre of gravity and one behind the centre of gravity.
- 1.4. No information is required about any elements of the bodywork, which are not parts of the superstructure.

2. Bays

- 2.1. A bay is defined as a structural section of the superstructure forming a closed loop between two planes which are perpendicular to the vertical longitudinal centre plane (VLCP) of the vehicle. A bay contains one window (or door) pillar on each side of the vehicle as well as side wall elements, a section of the roof structure and a section of the floor and underfloor structure. Every bay has a transverse centre plane (CP) perpendicular to the VLCP of the vehicle and passing through the centre points (C_p) of the window-pillars (see figure A4.2)
- 2.2. The C_p is defined as a point at half window height and halfway across the pillar width. If the C_p of the left-side and right-side pillars of a bay are not in the same transverse plane, the CP of the bay is set halfway between the transverse planes of the two C_p 's.
- 2.3. The length of a bay is measured in the direction of the longitudinal axis of the vehicle, and is determined by the distance between two planes perpendicular to the VLCP of the vehicle. There are two limits which define the length of a bay: the window (door) arrangement, and the shape and construction of the window (door) pillars.)

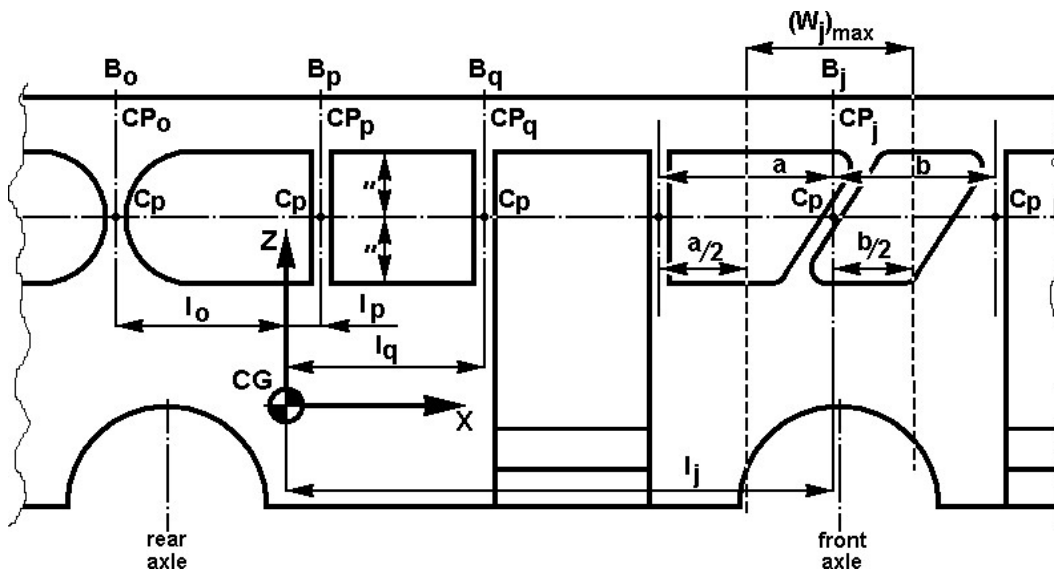

Figure A4. 2 - Definition of length of bays

2.3.1. The maximum length of a bay is defined by the length of the two neighbouring window (door) frames

$$(W_j)_{\max} = \frac{1}{2}(a + b)$$

where:

a = the length of the window (door) frame behind the j^{th} pillar, and

b = the length of the window (door) frame in front of the j^{th} pillar

If the pillars on opposite sides of the bay are not in one transverse plane, or the window frames on each side of the vehicle have different lengths (see figure A4.3), the overall length, W_j of the bay is defined by:

$$(W_j)_{\max} = \frac{1}{2}(a_{\min} + b_{\min} - 2L)$$

where:

a_{\min} = the smaller value of $a_{\text{right side}}$ or $a_{\text{left side}}$

b_{\min} = the smaller value of $b_{\text{right side}}$ or $b_{\text{left side}}$

L = the longitudinal offset between the centrelines of the pillars on the left and right sides of the vehicle

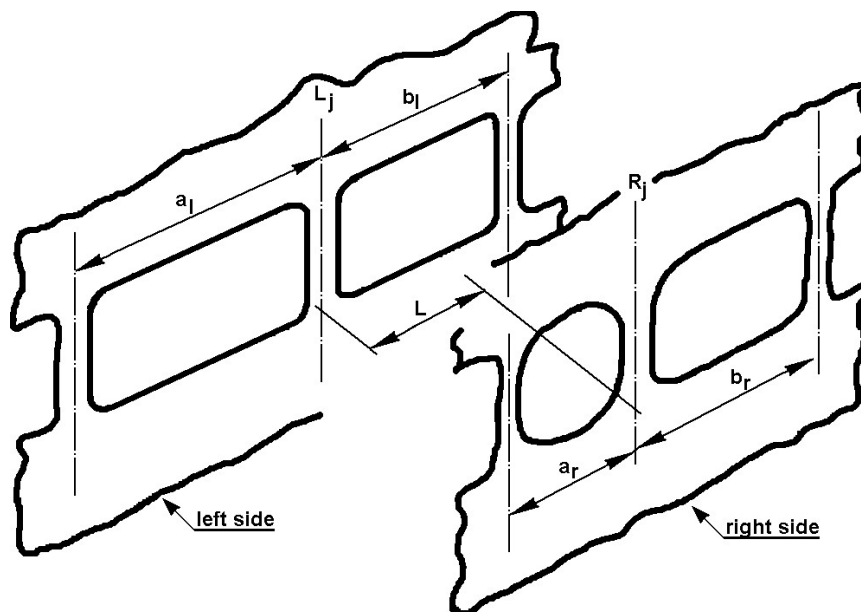

Figure A4.3 - Definition of bay length when pillars on each side of the bay are not in one transverse plane

2.3.2. The minimum length of a bay shall include the whole window pillar (including its inclination, corner radii, etc.). If the inclination and corner radii exceed half the length of the adjacent window then the next pillar shall be included in the bay.

2.4. The distance between two bays shall be defined as the distance between their CP's.

2.5. The distance of a bay from the centre of gravity of the vehicle shall be defined as the perpendicular distance from its CP to the vehicle centre of gravity.

3. Connecting structures between the bays

3.1. The connecting structures between bays shall be clearly defined in the superstructure. These structural elements fall into two distinct categories:

3.1.1. The connecting structures which form part of the superstructure. These elements shall be identified by the manufacturer, in this design submission: they include:

3.1.1.1. side-wall structure, roof structure, floor structure, which connect several bays,

3.1.1.2. structural elements which reinforce one or more bays; for example, boxes under seats, wheel arches, seat structures connecting side-wall to floor, kitchen, wardrobe and toilet structures.

3.1.2. The additional elements which do not contribute to the structural strength of the vehicle but which may intrude into the residual space, for example: ventilation ducts, hand luggage boxes, heating ducts.

4. Mass distribution

4.1. The manufacturer shall clearly define the portion of the mass of the vehicle attributed to each of the bays of the superstructure. This mass distribution shall express the energy absorbing capability and load bearing capacity of each bay. The following requirements shall be met when defining the distribution of mass:

4.1.1. the sum of the masses attributed to each bay shall be related to the mass M of the complete vehicle:

$$\sum_{j=1}^n (m_j) \geq M$$

where:

m_j = the mass attributed to the j^{th} bay

n = the number of bays in the superstructure

M = M_k , unladen kerb mass; or,

= M_t , total effective vehicle mass, as appropriate

- 4.1.2. the centre of gravity of the distributed masses shall be in the same position as the centre of gravity of the vehicle:

$$\sum_{j=1}^n (m_j l_j) = 0$$

where:

l_j = the distance of the j^{th} bay from the centre of gravity of the vehicle
(see paragraph 2.3.).

l_j is positive, if the bay is in front of the centre of gravity and negative if it is behind it.

- 4.2. The mass " m_j " of each bay of the superstructure shall be defined by the manufacturer, as follows:

- 4.2.1. the masses of the components of the " j^{th} " bay shall be related to its mass " m_j " by:

$$\sum_{k=1}^s m_{jk} \geq m_j$$

where:

m_{jk} = the mass of each component of the bay

s = the number of individual masses on the bay

- 4.2.2. the centre of gravity of the component masses of a bay shall have the same transverse position inside the bay as the bay's centre of gravity (see figure A4.4):

$$\sum_{k=1}^s m_{jk} y_k \equiv \sum_{k=1}^s m_{jk} z_k \equiv 0$$

where:

y_k = the distance of the k^{th} mass component of the bay from the axis "Z"
(see figure A4.4).

y_k will have a positive value on one side of the axis and a negative value on the other side.

z_k = the distance of the k^{th} mass component of the bay from the axis "Y",

z_k will have a positive value on one side of the axis and a negative value on the other side.

- 4.3. In the case where occupant restraints are part of the vehicle specification, the occupant mass attributed to a bay shall be attached to that part of the superstructure which is designed to absorb seat and occupant loadings.

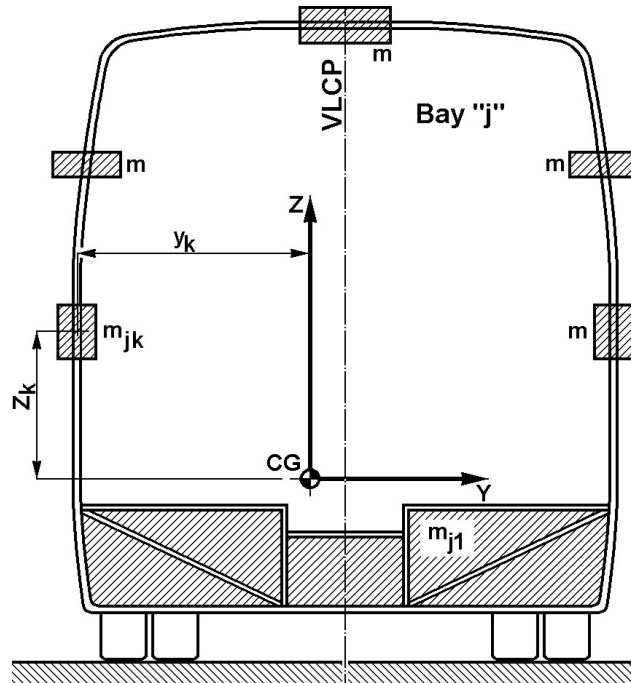

Figure A4.4 - Distribution of mass in the cross section of a bay

Annex 5

ROLLOVER TEST AS THE BASIC APPROVAL METHOD

1. The tilting bench

- 1.1. The tilting platform shall be sufficiently rigid and the rotation sufficiently controlled to ensure simultaneous lifting of the axles of the vehicle with a difference of less than 1° in the platform's tilt angles measured below the axles.
- 1.2. The height difference between the horizontal lower plane of the ditch (see figure.A5.1) and the plane of the tilting platform on which the bus is standing, shall be 800 ± 20 mm.
- 1.3. The tilting platform, related to the ditch, shall be placed as follows (see figure A5.1):
 - 1.3.1. the axis of its rotation is max 100 mm from the vertical wall of the ditch;
 - 1.3.2. the axis of the rotation is max 100 mm below the plane of the horizontal tilting platform.

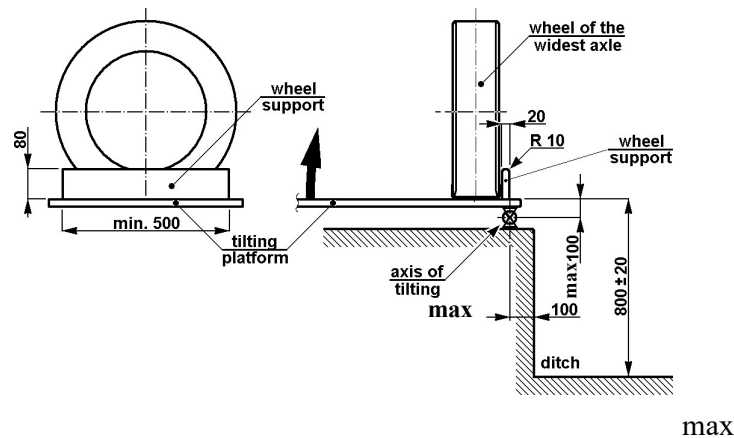

Figure A5.1 - Geometry of the tilting bench

- 1.4. Wheel supports shall be applied at the wheels being close to the axis of rotation against sliding of the vehicle sideways when tilting it. The main characteristics of the wheel supports (see figure A5.1) shall be:

- 1.4.1. dimensions of the wheel support:
- | | |
|-------------|---|
| Height | shall not be greater than two-thirds of the distance between the surface on which the vehicle stands before it is tilted and part of the rim of the wheel which is nearest to the surface |
| Width | 20 mm |
| Edge radius | 10 mm |
| Length | 500 mm minimum; |
- 1.4.2. the wheel supports at the widest axle shall be placed on the tilting platform so that the side of the tyre is at maximum 100 mm from the axis of rotation;
- 1.4.3. the wheel supports at the other axles shall be adjusted so that the vertical longitudinal centre plane (VLCP) of the vehicle shall be parallel to the axis of rotation.
- 1.5. The tilting platform shall be constructed to prevent the vehicle moving along its longitudinal axis.
- 1.6. The impact area of the ditch shall have a horizontal, uniform, dry and smooth concrete surface.
2. Preparation of test vehicle
- 2.1. The vehicle to be tested need not be in a fully finished, "ready for operation" condition. Generally, any alteration from the fully finished condition is acceptable if the basic features and behaviour of the superstructure are not influenced by it. The test vehicle shall be the same as its fully finished version in respect of the following:
- 2.1.1. the position of the centre of gravity, the total value of vehicle mass (unladen kerb mass, or total effective vehicle mass where restraints are fitted) and the distribution and location of masses, as declared by the manufacturer.
- 2.1.2. all of those elements which – according to the manufacturer - contribute to the strength of the superstructure shall be installed in their original position (see Annex 4 to this standard).
- 2.1.3. elements, which do not contribute to the strength of the superstructure and are too valuable to risk damage (e.g. drive chain, dashboard instrumentation, driver's seat, kitchen equipment, toilet equipment, etc.) can be replaced by additional elements equivalent in mass and method of installation. These additional elements must not have a reinforcing effect on the strength of superstructure.
- 2.1.4. fuel, battery acid and other combustible, explosive or corrosive materials may be substituted with other materials provided that the conditions of paragraph 2.1.1. are met.
- 2.1.5. In the case where occupant restraint devices are part of the vehicle type, a mass shall be attached to each seat fitted with an occupant restraint following one of these two methods, at the choice of the manufacturer:

- 2.1.5.1. First method: That mass shall be:
 - 2.1.5.1.1 50 per cent of the individual occupant mass (M_{mi}) of 68 kg,
 - 2.1.5.1.2. placed to have its centre of gravity 100 mm above and 100 mm forward of the R point of the seat.
 - 2.1.5.1.3. fixed rigidly and securely so that it does not break away during the test.
- 2.1.5.2 Second method: That mass shall be
 - 2.1.5.2.1 an anthropomorphic ballast with a mass of 68 kg and shall be restrained with a 2 point safety-belt. The ballast must allow guiding and positioning for safety-belts.
 - 2.1.5.2.2. placed to have its centre of gravity and dimensioning according to figure A5.2.
 - 2.1.5.2.3. fixed rigidly and securely so that it does not break away during the test.

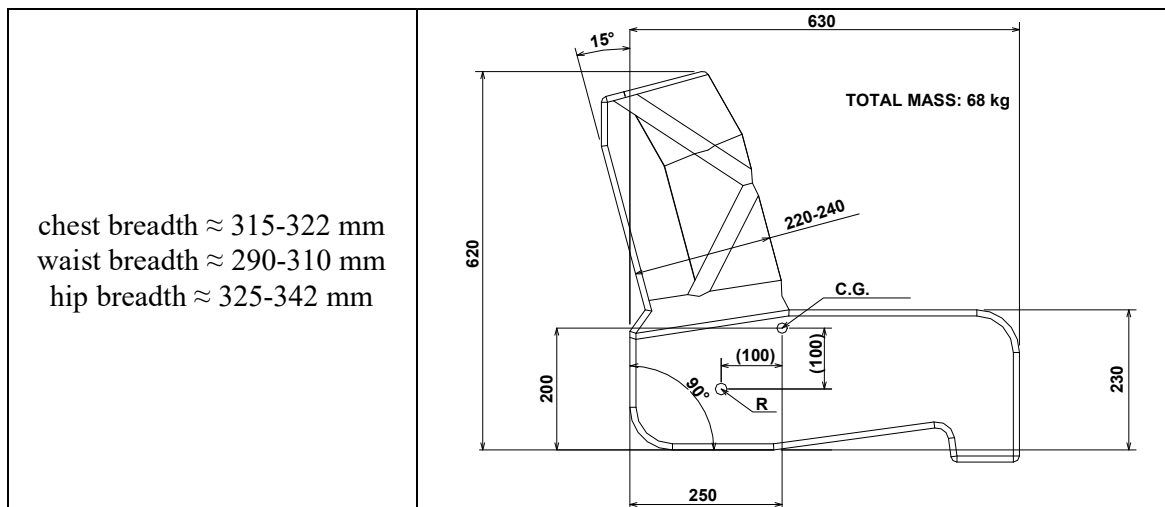

Figure A5.2.-Dimensions for the anthropomorphic ballast

- 2.2. The test vehicle shall be prepared as follows:
 - 2.2.1. tyres shall be inflated to the pressure prescribed by the manufacturer.
 - 2.2.2. the suspension system of the vehicle shall be blocked, i.e. the axles, the springs and the suspension elements of the vehicle shall be fixed in relation to the bodywork. The floor height above the horizontal tilting platform shall be according to the manufacturer's specification for the vehicle, dependent on whether it is loaded to unladen kerb mass or total vehicle mass.

- 2.2.3. every door and opening window of the vehicle shall be closed but not locked.
- 2.3. The rigid sections of an articulated vehicle may be tested separately or in combination.
 - 2.3.1. For testing the articulated sections as a combination, the sections of the vehicle shall be fixed to each other in such a way that,
 - 2.3.1.1. there is no relative movement between them during the roll-over process.
 - 2.3.1.2. there is no significant change in mass distribution and centre of gravity positions.
 - 2.3.1.3. there is no significant change in the strength and deformation capability of the superstructure.
 - 2.3.2. For testing the articulated sections separately, the single-axle sections shall be attached to an artificial support which keeps them in fixed relation to the tilting platform during its movement from the horizontal to the point of roll-over. This support shall meet the following requirements:
 - 2.3.2.1. it shall be fixed to the structure in such a way that it does not cause either reinforcement or extra additional load to the superstructure.
 - 2.3.2.2. it shall be constructed so that it does not suffer any deformation which could change the direction of the rollover of the vehicle.
 - 2.3.2.3. its mass shall be equal to the mass of those elements, parts of the articulated joint, which nominally belong to the section being tested, but which are not placed on it (e.g. turntable and its floor, handholds, rubber sealing curtains, etc.).
 - 2.3.2.4. its centre of gravity shall have the same height as the common centre of gravity of those parts which are listed in paragraph 2.3.2.3.
 - 2.3.2.5. it shall have an axis of rotation parallel to the longitudinal axis of the multi-axle section of the vehicle, and passing through the points of contact of the tyres of that section.
- 3. Test procedure, test process
 - 3.1. The rollover test is a very rapid, dynamic process having distinguishable stages, should be taken into consideration when a rollover test, its instrumentation and measurement are planned.
 - 3.2. The vehicle shall be tilted without rocking and without dynamic effects until it reaches unstable equilibrium and commences its rollover. The angular velocity of the tilt platform shall not exceed 5 degrees/sec. (0.087 radians/sec).
 - 3.3. For inside observation high-speed photography, video, deformable templates, electrical contact sensors or other suitable means shall be used to determine that the requirements of paragraph 5.1. of this standard has been met. This shall be verified at any places of the passenger, driver's and crew compartment where the residual space seems to be

endangered, the exact positions being at the discretion of the testing agency. At least two positions, nominally at the front and rear of the passenger compartment(s) shall be used.

- 3.4. Outside observation and recording of the rollover and deformation process is recommended, which means the following:
 - 3.4.1. two high-speed cameras - one at the front and another at the rear . They should be located far enough from the front and rear wall of the vehicle to produce a measurable picture, avoiding wide-angle distortion. in the shaded area, as shown in figure A5.3a.
 - 3.4.2. the position of the centre of gravity and the contour of the superstructure (see figure A5.3b), is marked by stripes and bands to ensure correct measurements on the pictures.

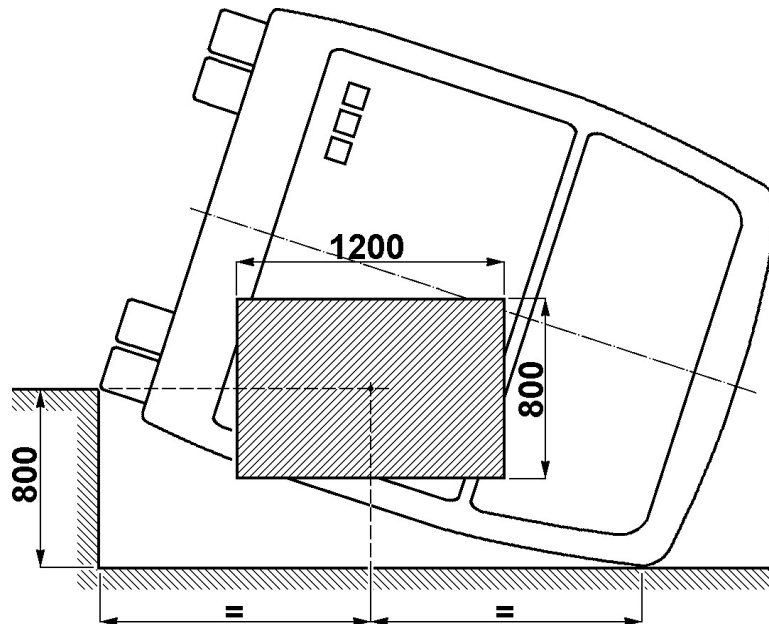

Figure A5.3a - Recommended field of view of outside camera

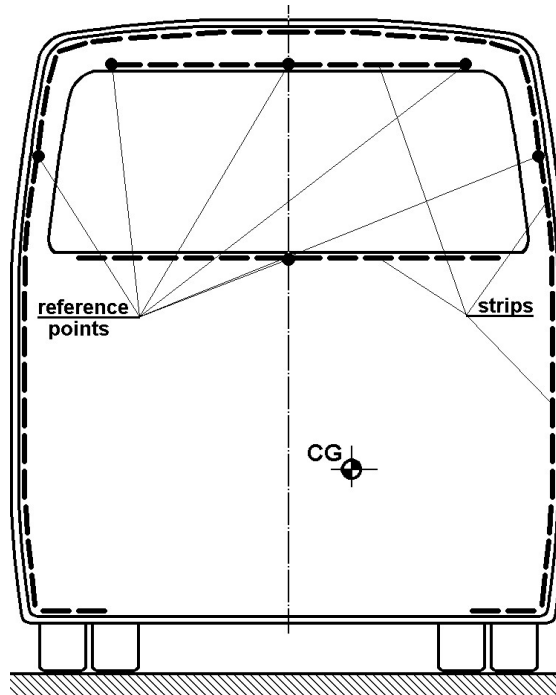

Figure A5.3b - Recommended marking of the centre of gravity position and the contour of the vehicle

4. Documentation of the rollover test

4.1. Detailed description of the tested vehicle shall be given by the manufacturer in which:

4.1.1. all the deviations between the fully finished vehicle type in running order and the tested vehicle are listed.

4.1.2. the equivalent substitution (in respect of mass, mass distribution and installation) shall be proved in every case, when structural parts, units are substituted by other units or masses.

4.1.3. there is a clear statement of the position of centre of gravity in the tested vehicle which may be based on measurements carried out on the test vehicle when it is ready for test, or a combination of measurement (carried out on the fully finished vehicle type) and calculation based on the mass substitutions.

4.2. The test report shall contain all the data (pictures, records, drawings, measured values, etc.) which show:

4.2.1. that test was carried out according to this annex;

4.2.2. that the requirements given in paragraphs 5.1.1. and 5.1.2. of this standard are met (or not);

4.2.3. the individual evaluation of inside observations;

- 4.2.4. all the data and information needed for the identification of the vehicle type, the test vehicle, the test itself, and the personnel responsible for the test and its evaluation.
- 4.3. It is recommended to document in the test report the centre of gravity's highest and lowest position related to the ground level of the ditch.

Annex 6

ROLLOVER TEST USING BODY SECTIONS AS AN EQUIVALENT APPROVAL METHOD

1. Additional data and information

If the manufacturer chooses this method of testing, the following information shall be given to the testing agency in addition to the data, information and drawings listed in paragraph 3. of this standard:

- 1.1. drawings of the body sections to be tested;
- 1.2. verification of the validity of the distribution of masses given in Annex 4, paragraph 4., upon successful completion of the body section rollover tests;
- 1.3. the measured masses of the body sections to be tested, and verification that their centre of gravity positions are the same as that of the vehicle with unladen kerb mass if not fitted with occupant restraints, or with total effective vehicle mass if occupant restraints are fitted. (Presentation of measuring reports)

2. The tilting bench

The tilting bench shall meet the requirements given in Annex 5, paragraph 1.

3. Preparation of body sections

- 3.1. The number of the body sections to be tested shall be determined by the following rules:
 - 3.1.1. all the different bay configurations which are part of the superstructure shall be tested in at least one body section;
 - 3.1.2. every body section shall have at least two bays;
 - 3.1.3. in an artificial body section (see paragraph 2.28. of this standard) the ratio of the mass of any one bay to any other bay shall not exceed 2;
 - 3.1.4. the residual space of the whole vehicle shall be well represented in the body sections, including any peculiar combinations arising from the vehicles bodywork configuration;
 - 3.1.5. the whole roof structure shall be well represented in the body sections if there are local specialities, like changing height, air condition installation, gas tanks, luggage carrier, etc.
- 3.2. The bays of the body section shall be exactly the same structurally as they are represented in the superstructure, as regards shape, geometry, material, joints.

- 3.3. The connecting structures between the bays shall represent the manufacturer's description of the superstructure (see Annex 4, paragraph 3.) and the following rules shall be considered:
 - 3.3.1. in the case of an original body section taken directly from the actual vehicle layout, the basic and the additional connecting structures (see Annex 4 paragraph 3.1.) shall be the same as that of the vehicle superstructure;
 - 3.3.2. in the case of an artificial body section, the connecting structures shall be equivalent in terms of strength, stiffness and behaviour to that of the vehicle superstructure;
 - 3.3.3. those rigid elements which are not part of the superstructure but which can encroach on the residual space during deformation, shall be installed into the body sections;
 - 3.3.4. the mass of the connecting structures shall be included in the mass distribution, in terms of attribution to a particular bay and distribution within that bay.
- 3.4. The body sections shall be equipped with artificial supports, to provide the same centre of gravity positions and axis of rotation for them on the tilting platform as that of the complete vehicle. The supports shall meet the following requirements:
 - 3.4.1. they shall be fixed to the body section in such a way that they do not provide either reinforcement or extra additional load on the body section;
 - 3.4.2. they shall be sufficiently strong and rigid to resist any deformation which could change the direction of the body section motion during the tilting and rollover process;
 - 3.4.3. their mass shall be included in the mass distribution and centre of gravity position of the body section.
- 3.5. The distribution of mass in the body section shall be arranged with the following considerations:
 - 3.5.1. the whole body section (bays, connecting structures, additional structural elements, supports) shall be considered when checking the validity of two equations, given in Annex 4, paragraph 4.2.1 and 4.2.2;
 - 3.5.2. any masses attached to the bays (see paragraph 4.2.2. and figure 4 of Annex 4) shall be placed and fixed to the body section in such a way that they do not cause reinforcement or additional load or limitation of the deformation.
 - 3.5.3. In the case where occupant restraints are part of the vehicle type, the occupant masses shall be considered as described in Annex 4 and Annex 5.

4. Test procedure

The test procedure shall be the same as described in paragraph 3. of Annex 5 for a complete vehicle.

5. Evaluation of the tests

5.1. The vehicle type shall be approved if all the body sections pass the rollover test and two equations ~~2 and 3~~ in paragraph 4.1.1. and 4.1.2 of Annex 4 are fulfilled.

5.2. If one of the body sections fails the test, the vehicle type shall not be approved.

5.3. If a body section passes the rollover test, each of the bays which form that body section are considered to have passed the rollover test, and the result can be quoted used in future applications for approval, provided that the ratio of their masses remains the same in the subsequent superstructure .

5.4. If a body section fails the rollover test, all the bays within that body section shall be considered to have failed the test even if the residual space is invaded in only one of the bays.

6. Documentation of body section rollover tests

The test report shall contain all the data necessary to demonstrate:

6.1. The construction of the tested body sections (dimensions, materials, masses, centre of gravity position, construction methods).

6.2. that the tests were carried out according to this annex

6.3. whether, or not, the requirements - given in paragraph 5.1. of this standard - are met

6.4. the individual evaluation of the body sections and their bays.

6.5. the identity of the vehicle type, its superstructure, the tested body sections, the tests themselves and the personnel responsible for the tests and their evaluation.

Annex 7

QUASI- STATIC LOADING TEST OF BODY SECTIONS AS AN EQUIVALENT
APPROVAL METHOD

1. Additional data and information

This method of testing uses body sections as test units, each one built up from at least two bays of the vehicle under appraisal, connected together with representative structural elements. If the manufacturer chooses this method of testing, the following additional information shall be supplied to the testing agency, in addition to the data, and drawings listed in paragraph 3.2. of this standard:

- 1.1. drawings of the body sections to be tested.
- 1.2. energy values to be absorbed by the individual bays of the superstructure, as well as the energy values belonging to the body sections to be tested.
- 1.3. verification of the energy requirement, see paragraph 4.2. below, upon completion of successful quasi-static loading tests of body sections.

2. Preparation of body sections

- 2.1. The manufacturer shall consider the requirements given in annex 6, paragraphs 3.1., 3.2., and 3.3., when designing and producing the body sections for test.
- 2.2. The body sections shall be equipped with the residual space profile, at positions where it is considered that the pillars or other structural elements are likely to intrude as a result of the expected deformation.

3. Test procedure

- 3.1. Each body section to be tested shall be firmly and securely attached to the test bench through a rigid underframe structure in such a way that,
 - 3.1.1. local plastic deformation shall not occur around the attachment points;
 - 3.1.2. the location and method of attachment shall not inhibit the formation and working of expected plastic zones and hinges.
- 3.2. For application of the load to the body section, the following rules shall be considered:
 - 3.2.1. the load shall be evenly distributed on the cantrail, through a rigid beam, which is longer than the cantrail to simulate the ground in a rollover test, and which follows the geometry of the cantrail.

3.2.2. the direction of the applied load (see figure A7.1) shall be related to the longitudinal vertical centre plane of the vehicle and its inclination (α) shall be determined as follows:

$$\alpha = 90^\circ - \arcsin\left(\frac{800}{H_c}\right)$$

where:

H_c = the cantrail height (in mm) of the vehicle measured from the horizontal plane on which it is standing.

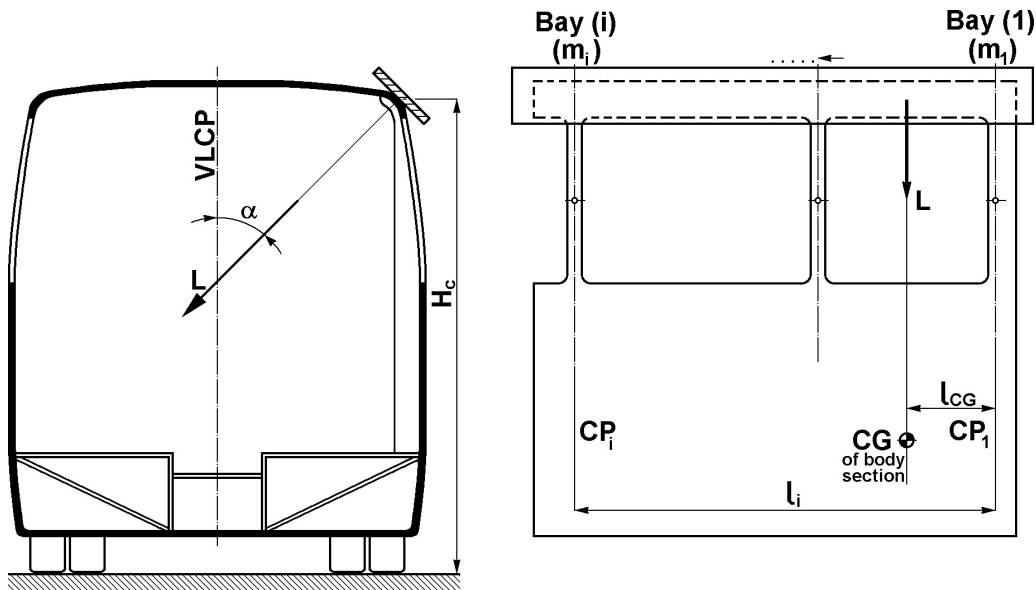

Figure A7.1 - Application of load to the body section

3.2.3. the load shall be applied to the beam at the centre of gravity of the body section derived from the masses of its bays and the structural elements connecting them. Using the symbols of Figure A.7.1, the position of the body section can be determined by the following formula:

$$l_{CG} = \frac{\sum_{i=1}^s m_i l_i}{\sum_{i=1}^s m_i}$$

where:

s = the number of the bays in the body section

m_i = the mass of the i^{th} bay

- l_i = the distance of the centre of gravity of the i^{th} bay from a selected pivot point (the central plane of Bay(1) in figure A7.1)
 l_{CG} = the distance of the centre of gravity of the body section from the same selected pivot point.

- 3.2.4. the load shall be increased gradually, taking measurements of the associated deformation at discrete intervals until the ultimate deformation (d_u) when the residual space is invaded by one of the elements of the body section.
- 3.3. When plotting the load-deflection curve:
- 3.3.1. the frequency of measurement shall be such as to produce a continuous curve (see figure A.7.2).
- 3.3.2. the values of load and deformation shall be measured simultaneously.
- 3.3.3. the deformation of the loaded cantrail shall be measured in the plane and direction of the applied load.
- 3.3.4. both load and deformation shall be measured to an accuracy of ± 1 per cent.
4. Evaluation of test results
- 4.1. From the plotted load-deflection curve the actual energy absorbed by the body section (E_{BS}) shall be expressed as the area below the curve (see figure A.7.2).

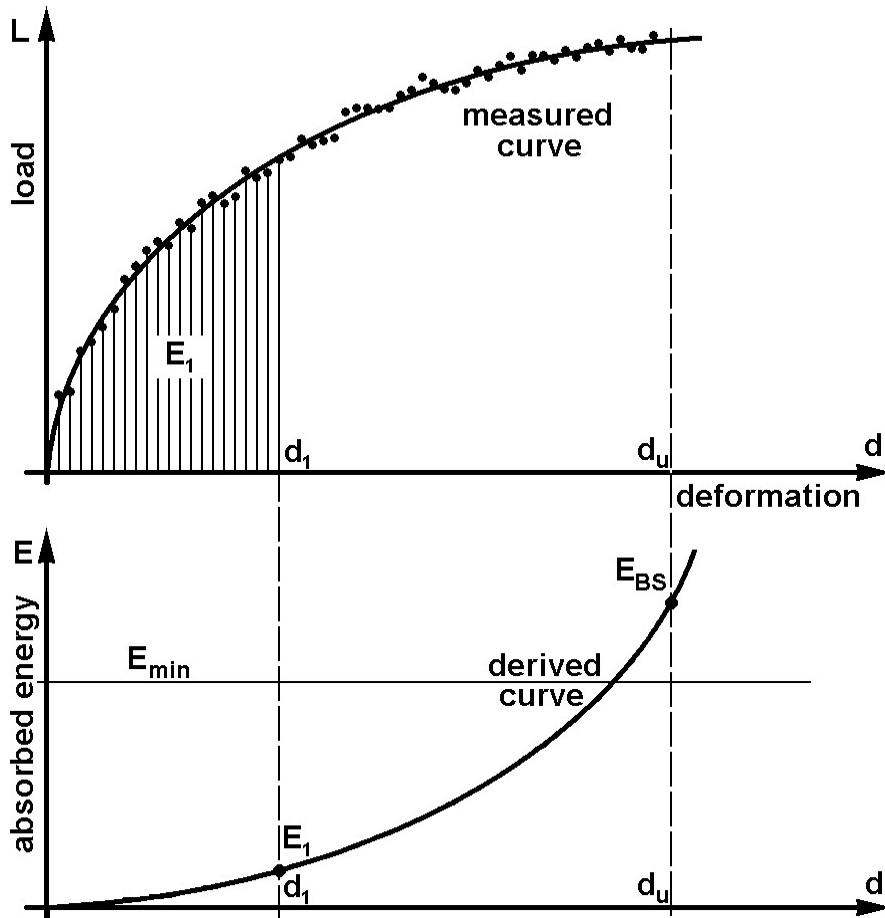

Figure A7.2 - Absorbed energy for the body section, derived from the measured load-deformation curve

4.2. The minimum energy required to be absorbed by the body section (E_{min}) shall be determined as follows:

4.2.1. the total energy (E_T) to be absorbed by the superstructure is:

$$E_T = 0.75 M g \Delta h$$

where:

- $M = M_k$, unladen kerb mass of the vehicle if there are no occupant restraints; or, M_t , total effective vehicle mass when occupant restraints are fitted,
- g = gravitational constant,
- Δh = the vertical movement (in metres) of the vehicle centre of gravity during a rollover test, as determined in appendix 1 to this annex.

- 4.2.2. the total energy " E_T " shall be distributed among the bays of the superstructure in the proportions of their masses:

$$E_i = E_T \frac{m_i}{M}$$

where:

E_i = the absorbed energy by the " i^{th} " bay

m_i = mass of the " i^{th} " bay, as determined in annex 4, paragraph 4.1

- 4.2.3. the minimum energy required to be absorbed by the body section (E_{min}) is the sum of the energy of the bays comprising the body section:

$$E_{min} = \sum_{i=1}^S E_i$$

- 4.3. The body section passes the loading test, if:

$$E_{BS} \geq E_{min}$$

In this case, all the bays which form that body section are considered to have passed the quasi-static loading test and these results can be quoted in future requests for approval provided that the component bays are not expected to carry a greater mass in the subsequent superstructure.

- 4.4. The body section fails the loading test if:

$$E_{BS} < E_{min}$$

In this case all the bays which form that body section are considered to have failed the test even if the residual space is invaded in only one of the bays.

- 4.5. The vehicle type shall be approved if all the required body sections pass the loading test.

5. Documentation of body section quasi-static loading tests

The test report shall follow the form and content of Annex 6, paragraph 6.

Annex 7 - Appendix 1

DETERMINATION OF THE VERTICAL MOVEMENT OF THE CENTRE OF GRAVITY
DURING ROLLOVER

The vertical movement (Δh) of centre of gravity related to the rollover test may be determined by the graphical method shown below.

1. Using scaled drawings of the cross-section of the vehicle, the initial height (h_1) of the centre of gravity (position 1) above the lower plane of the ditch is determined for the vehicle standing at its point of unstable equilibrium on the tilting platform (see Figure A7.A1.1).
2. Using the assumption that the vehicle cross-section rotates around the edge of the wheel supports, (point A in Figure A7.A1.1) the vehicle cross-section is drawn with its cantrail just touching the lower plane of the ditch (see Figure A7.A1.2). In this position the height (h_2) of the centre of gravity (position 2) relative to the lower plane of the ditch is determined.

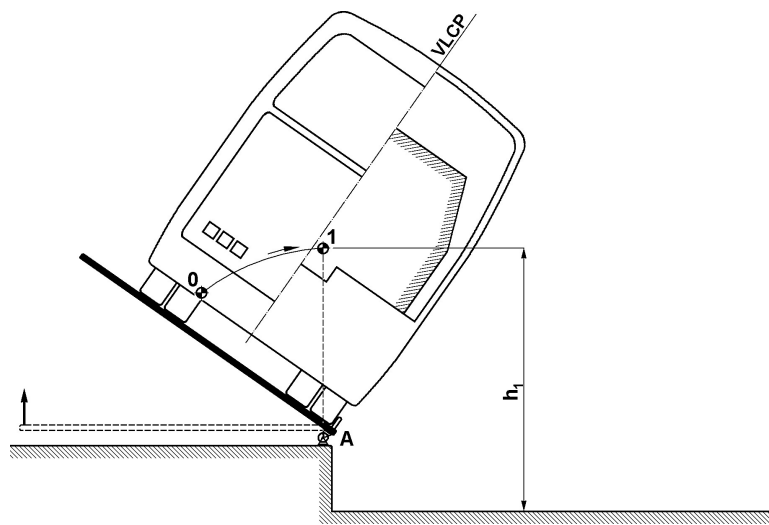

Figure A7.A1.1 Initial height of the vehicle centre of gravity

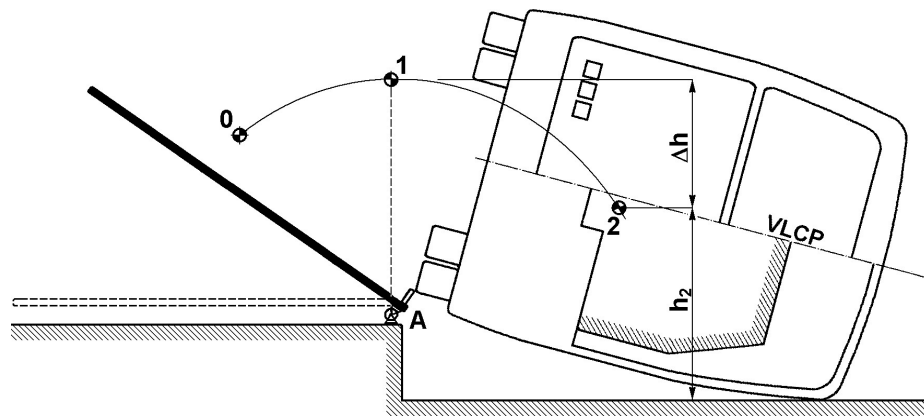

Figure A7.A1.2 - Determination of the vertical movement of the vehicle centre of gravity

3. The vertical movement of the centre of gravity (Δh) is,

$$\Delta h = h_1 - h_2$$

4. If more than one body sections are tested and each body section has a different vertical movement (Δh_i), the vertical movement of centre of gravity (Δh_i) shall be determined for each body section and the combined mean value (Δh) is taken as,

$$\Delta h = \frac{1}{k} \sum_{i=1}^k \Delta h_i$$

where:

Δh_i = the vertical movement of the centre of gravity of the i^{th} body section,
 k = the number of body sections tested.

Annex 8

QUASI-STATIC CALCULATION BASED ON TESTING OF COMPONENTS AS AN
EQUIVALENT APPROVAL METHOD

1. Additional data and information

If the manufacturer chooses this test method, the following information shall be given to the testing agency, in addition to the data and drawings listed in paragraph 3.2. of this standard:

- 1.1. The location of plastic zones (PZ) and plastic hinges (PH) in the superstructure;
 - 1.1.1. all the individual PZ's and PH's shall be uniquely identified on the drawing of the superstructure in their geometrically defined locations (see figure A.8.1.)
 - 1.1.2. structural elements between the PZ's and PH's can be treated as rigid or elastic parts in the calculation, and their length shall be determined by their actual dimensions in the vehicle.
- 1.2. The technical parameters of PZ's and PH's;
 - 1.2.1. the cross-sectional geometry of the structural elements in which the PZ's and PH's are located.
 - 1.2.2. the type and direction of loading applied to each PZ and PH.
 - 1.2.3. the load-deformation curve of each PZ and PH as described in appendix 1 of this annex. The manufacturer may use either the static, or the dynamic characteristics of the PZ's and PH's for the calculation but shall not mix static and dynamic characteristics in one calculation.

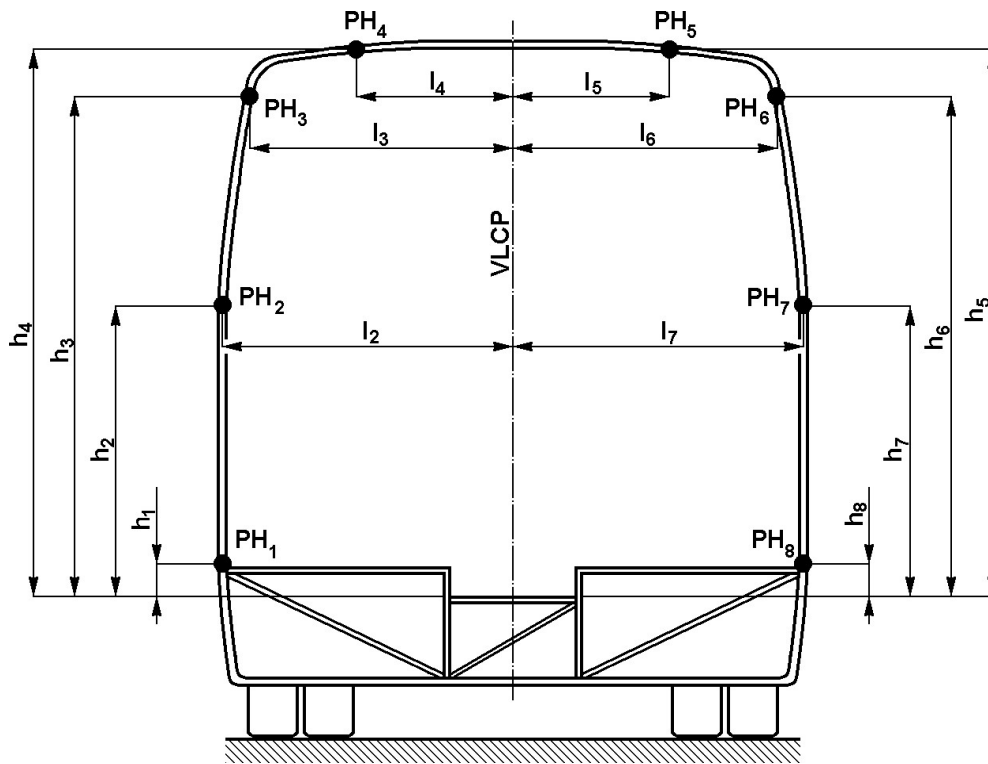

Figure A8. 1 - Geometrical parameters of plastic hinges on a bay

- 1.3. A statement of the total energy (E_T) to be absorbed by the superstructure, using the formula stated in paragraph 3.1. below.
- 1.4. A brief technical description of the algorithm and computer program which are used for the calculation.
2. Requirements for the quasi-static calculation
 - 2.1. For the calculation, the complete superstructure shall be mathematically modelled as a load-bearing and deformable structure, taking account of the following:
 - 2.1.1. the superstructure shall be modelled as a single loaded unit containing deformable PZ's and PH's, connected by appropriate structural elements.
 - 2.1.2. the superstructure shall have the actual dimensions of the bodywork. The inner contour of the side-wall pillars and roof structure shall be used when checking the residual space.
 - 2.1.3. the PH's shall utilise the actual dimensions of the pillars and structural elements on which they are located (see Appendix 1 of this annex).
 - 2.2. The applied loads in the calculation shall meet the following requirements:

- 2.2.1. the active load shall be applied in the transverse plane containing the centre of gravity of the superstructure (vehicle) which is perpendicular to the vertical longitudinal centre plane (VLCP) of the vehicle. The active load shall be applied on the cantrail of the superstructure through an absolutely rigid load application plane, which extends in both directions beyond the cantrail and any adjacent structure.
- 2.2.2. At the beginning of the simulation the load application plane shall touch the cantrail at its most distant part from the vertical longitudinal central plane. The contact points between the load application plane and the superstructure shall be defined to ensure an exact load transfer.
- 2.2.3. the active load shall have an inclination α related to the vertical longitudinal centre plane of the vehicle (see figureA.8.2).

$$\alpha = 90^{\circ} - \arcsin\left(\frac{800}{H_c}\right)$$

where:

H_c = the cantrail height (in mm) of the vehicle measured from the horizontal plane on which it is standing.

The direction of action of the active load shall not be changed during the calculation.

- 2.2.4. the active load shall be increased by small incremental steps and the whole structural deformation shall be calculated at every loading step. The number of loading steps shall exceed 100 and the steps shall be quasi-equal.
- 2.2.5. during the deformation process the load application plane may, in addition to parallel translation, be allowed to rotate around the axis of intersection of the load application plane with the transverse plane containing the centre of gravity, in order to follow the asymmetric deformation of the superstructure.
- 2.2.6. the passive (supporting) forces shall be applied on the rigid underfloor structure causing no influence on the structural deformation.

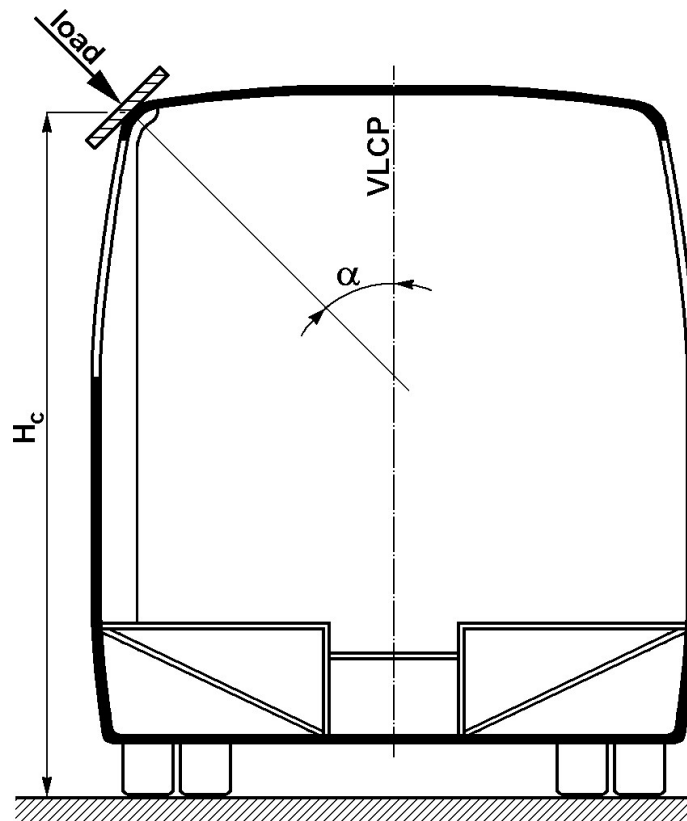

Figure A8. 2 - Load application to the superstructure

- 2.3. The algorithm of the calculation and the computer program shall meet the following requirements:
 - 2.3.1. the program shall take account of non-linearities in the PH characteristics and large scale structural deformations.
 - 2.3.2. the program shall accommodate the working range of PH's and PZ's and shall stop the calculation if the deformation of PH's exceeds the validated working range (see Appendix 1 of this annex).
 - 2.3.3. the program shall be able to calculate the total energy absorbed by the superstructure at every incremental load step.
 - 2.3.4. at every incremental load step, the program shall be able to demonstrate the deformed shape of the bays forming the superstructure, and the position of every rigid part which may intrude into the residual space. The program shall identify the incremental load step at which the residual space is first invaded by any of the rigid structural parts.

- 2.3.5. the program shall be able to detect and identify the incremental load step at which overall collapse of the superstructure begins; when the superstructure becomes unstable and deformation continues without an increase of the load.

3. Evaluation of the calculation

- 3.1. The total energy (E_T) to be absorbed by the superstructure shall be determined as follows:

$$E_T = 0.75 M \cdot g \cdot \Delta h$$

where:

$M = M_k$ the unladen kerb mass of the vehicle, if there are no restraints, or
 M_t the total effective vehicle mass when occupant restraints are fitted

$G =$ the gravitational constant

$\Delta h =$ the vertical movement (in metres) of the vehicle centre of gravity during a rollover test, as determined in Appendix 1 of Annex 7

- 3.2. The absorbed energy (E_a) of the superstructure is calculated at the incremental load step at which the residual space is first touched by any of the rigid structural parts.

- 3.3. The vehicle type shall be approved if $E_a \geq E_T$

4. Documentation of quasi-static calculation

The calculation report shall contain the following information:

- 4.1. detailed mechanical description of the superstructure containing the location of PZ's and PH's and defining the rigid and elastic parts,
- 4.2. data obtained from the tests and the resultant graphs,
- 4.3. a statement of whether or not the requirement of paragraph 5.1. of this standard are met,
- 4.4. identification of the vehicle type and the personnel responsible for the tests, the calculations, and the evaluation.

Annex 8 - Appendix 1

CHARACTERISTICS OF PLASTIC HINGES

1. Characteristic curves

The general form of a Plastic Zone (PZ) characteristic curve is a non-linear load-deformation relationship measured on structural parts of the vehicle in laboratory tests. Plastic Hinge characteristic curves are a bending moment (M) - rotational angle (φ) relationship. The general form of a PH characteristic curve is shown in Figure A.8. A.1.1

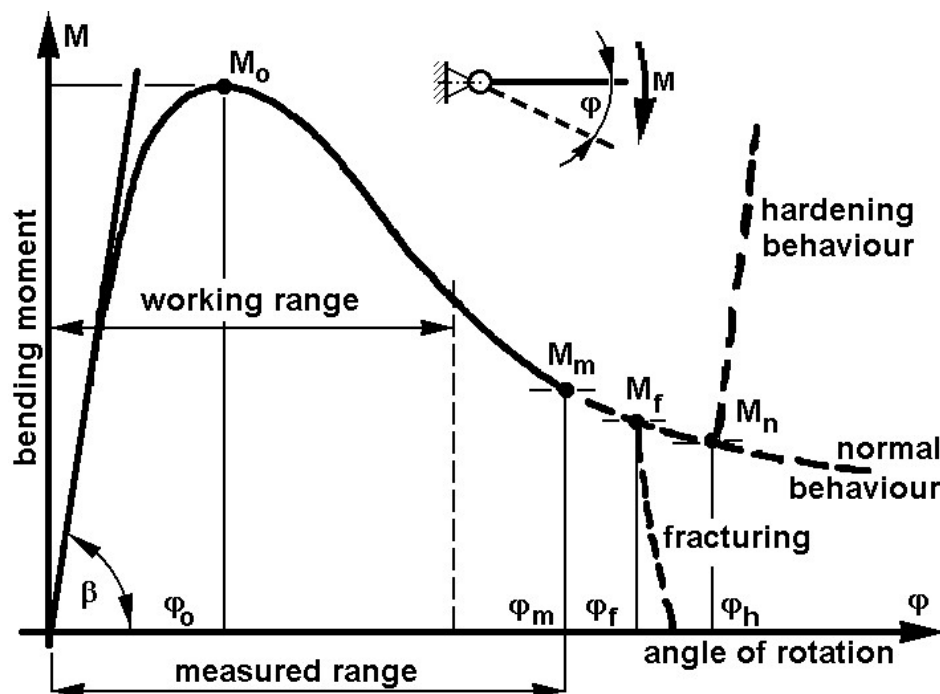

Figure A8. A1.1 - Characteristic curve for a plastic hinge

2. Aspects of deformation ranges

2.1. The "measured range" of the PH characteristic curve is the range of deformation over which measurements have been made. The measured range may contain the fracture, and/or the rapid hardening range. Only values of the PH characteristics which appear in the measured range shall be used in the calculation.

2.2. The "working range" of the PH characteristic curve is the range covered by the calculation.

The working range shall not exceed the measured range, and may contain the fracture, but not the rapid-hardening range.

2.3. The PH characteristics to be used in the calculation shall contain the M- ϕ curve in the measured range.

3. Dynamic Characteristics

There are two kinds of PH and PZ characteristics: quasi-static and dynamic. The dynamic characteristics of a PH may be determined in two ways:

3.1. by dynamic impact testing of the component.

3.2. by using a dynamic factor K_d to transform the quasi-static PH characteristics. This transformation means that the values of the quasi-static bending moment may be increased by K_d .

For steel structural elements $K_d = 1.2$ may be used without laboratory test.

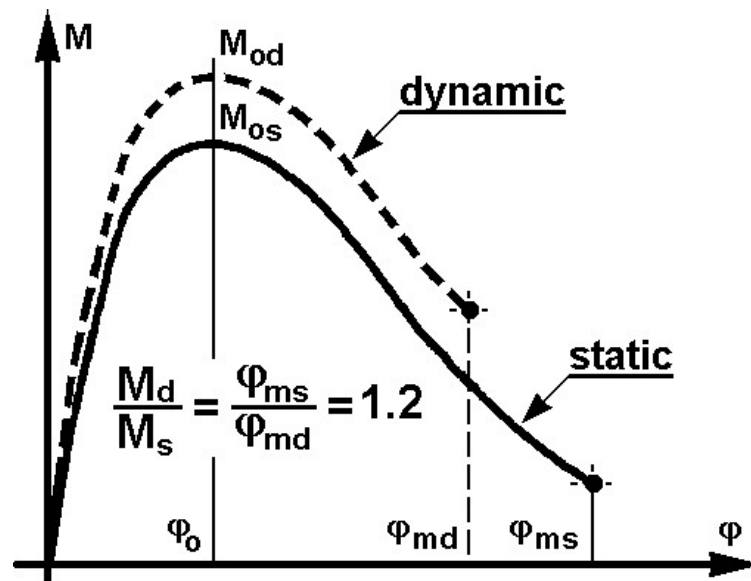

Figure A8. A 1.2 - Derivation of plastic hinge dynamic characteristics from the static curve

Annex 9

COMPUTER SIMULATION OF ROLLOVER TEST ON COMPLETE VEHICLE AS AN EQUIVALENT APPROVAL METHOD

1. Additional data and information

The superstructure may be shown to meet the requirements specified in paragraphs 5.1.1. and 5.1.2. of this standard by a computer simulation method approved by the testing agency.

If the manufacturer chooses this testing method, the following information shall be supplied to the testing agency in addition to the data, and drawings listed in paragraph 3.2. of this standard;

- 1.1. A description of the applied simulation and calculation method which has been utilised, and clear precise identification of the analysis software, including at least, its producer, its commercial name, the version used and contact details of the developer.
- 1.2. The material models and the input data utilized.
- 1.3. The values for defined masses, centre of gravity and the moments of inertia used in the mathematical model.

2. The mathematical model

The model shall be capable of describing the real physical behavior of the rollover process, in accordance with Annex 5. The mathematical model shall be constructed, and assumptions prescribed, in such a way that the calculation gives conservative results. The model shall be built up with the following considerations:

- 2.1. the testing agency may require tests to be carried out on the actual vehicle structure to prove the validity of the mathematical model and to verify the assumptions made in the model.
- 2.2. the total mass and the centre of gravity position used in the mathematical model shall be identical to those of the vehicle to be approved.
- 2.3. the mass distribution in the mathematical model shall correspond to the vehicle to be approved. Moments of inertia used in the mathematical model shall be calculated on the basis of this mass distribution.

3. Requirements for the algorithm and simulation program, and for computing equipment

- 3.1. The position of the vehicle in unstable equilibrium at point of rollover, and the position at first contact with the ground shall be specified. The simulation program may start at the

unstable equilibrium position, but shall start, at the latest, at the point of first contact with the ground.

- 3.2. The initial conditions at the point of first contact with the ground shall be defined using the change of potential energy from the unstable equilibrium position.
- 3.3. The simulation program shall run, at least, until the maximum deformation is reached.
- 3.4. The simulation program shall produce a stable solution, in which the result is independent of the incremental time step.
- 3.5. The simulation program shall be able to calculate the energy components for the energy balance at every incremental time step.
- 3.6. Non-physical energy components introduced by the process of mathematical modelling (for example, "hourglass" and internal damping) shall not exceed 5 per cent of the total energy at any time.
- 3.7. The friction coefficient used at the ground contact shall be validated with physical test results, or the calculation shall prove that the friction coefficient chosen produces conservative results.
- 3.8. All the possible physical contacts between parts of the vehicle shall be taken into account in the mathematical model.

4. Evaluation of the simulation

- 4.1. When the stated requirements for the simulation program are met, the simulation of the changes in geometry of the interior structure and comparison with the geometrical shape of the residual space can be evaluated as defined in the paragraphs 5.1. and 5.2. of this standard.
- 4.2. If the residual space is not infringed during the rollover simulation, the approval shall be granted.
- 4.3. If the residual space is infringed during the rollover simulation, the approval shall be refused.

5. Documentation

- 5.1. The report on the simulation shall contain the following information:
 - 5.1.1. all the data and information stated in paragraph 1. of this annex,
 - 5.1.2. a drawing showing the mathematical model of the superstructure,

- 5.1.3. a statement of the values of angle, velocity, and angular velocity at the unstable equilibrium position of the vehicle and at the position of first contact with the ground,
- 5.1.4. a table of the value of the total energy and the values of all its components (kinetic energy, internal energy, hourglass energy), at time increments of 1 ms covering, at least, the period from first contact with the ground until the maximum deformation is reached,
- 5.1.5. the assumed ground friction coefficient,
- 5.1.6. plots or data which show in an appropriate way that the requirements specified in paragraphs 5.1.1. and 5.1.2. of this standard are met. This requirement can be satisfied by the provision of a plot, against time, of the distance between the inside contour of the deformed structure and the periphery of the residual space,
- 5.1.7. a statement of whether, or not, the requirements specified in paragraphs 5.1.1. and 5.1.2. of this standard have been met,
- 5.1.8. all the data and information necessary for the clear identification of the vehicle type, its superstructure, the mathematical model of the superstructure, and the calculation itself.
- 5.2. It is recommended that the report also contains plots of the deformed structure at the moment when maximum deformation occurs, giving an overview of the superstructure and regions of large plastic deformation.
- 5.3. At the request of the testing agency, further information shall be provided and included in the report.
